

# REPAIR MANUAL

**4 HP - 18 Q**

PSA Version



**ZF GETRIEBE GMBH SAARBRÜCKEN**



**Impressum:**

Verantwortlich für den Inhalt  
Abteilung MKTD, ZF Getriebe GmbH,  
Saarbrücken

Druck: Hermann Hager GmbH, Quierschied  
Gedruckt in der BRD

Published by ZF Getriebe GmbH,  
Saarbrücken, Department-MKTD  
Printed in West Germany by  
Hermann Hager GmbH, Quierschied.



# CONTENTS

	<b>Page</b>
<b>Preliminary information</b>	<b>1</b>
<b>1. General remarks</b>	<b>2</b>
1.1 Drawing of transmission	2
1.2 Power flow schematic	3
1.3 Oil circuits	4/1
1.4 Adjustment work	5/1
1.4.1 Clearance in selector shaft mechanism (washer)	5/1
1.4.2 Clearance at brake D (snap ring)	5/2
1.4.3 Clearance at clutch A (snap ring)	5/3
1.4.4 Clearance at brake C (snap ring)	5/4
1.4.5 Endplay (washer)	5/5
1.4.6 Spur gear drive	5/7
1.4.6.1 Output shaft preload (washer)	5/7
1.4.6.2 Side shaft play (washer)	5/10
1.4.7 Preload at differential (washer)	5/13
1.4.8 Brake band (tightening torque)	5/16
1.4.9 Throttle cable setting (full throttle)	5/17
1.4.10 Checking position switchr	5/17
1.4.11 Adjusting differential (clearance)	5/17
1.5 Tightening torques	6
1.6 Troubleshooting (faults, possible causes and remedies)	7/1
1.7 Checking the transmission	8
1.8 Special tools	9/1
<b>2. Dismantling</b>	<b>10</b>
2.1 Dismantling the transmission according to assembly groups	10
2.2 Brake C'	22
2.3 Brake D'	23
2.4 Intermediate plate with brake C and pump	24
2.5 Clutch B with 2nd gear freewheel	26
2.6 Clutch A	28
2.7 Clutch E	30
2.8 Output shaft and 1st gear freewheel	32
2.9 Governor and differential	33
2.10 Bell housing and extension (speedometer)	37
2.11 Housing with shift and parking pawl	38
<b>3. Assembling</b>	<b>45</b>
3.1 Transmission housing with shift and parking pawl	45
3.2 Brake C'	56
3.3 Brake D with 1st gear freewheel	60
3.4 Planetary gear set with input and output components	64
3.5 Engine shaft with clutch E	69
3.6 Clutch A	72
3.7 Clutch B	76
3.8 Intermediate plate with pump and brake C, 2nd gear freewheel	79
3.9 Governor, side shaft and spur gear drive	87
3.10 Differential and converter dome with extension (speedometer)	94
3.11 Control unit, oil pan, oil filter and converter	102



# PRELIMINARY INFORMATION

This manual contains precise details of how to repair the complete transmission.

All dismantling and assembly work is described in the correct order.

The photographs cover various types of transmission and may therefore differ from the vehicle on which you are working.

The component list precisely defines which version of the transmission you are working on, and this is also reflected in the parts list.

If any major modifications have to be taken into account when repairs are carried out, you will be notified by Technical Bulletin.

Depending on the nature of the fault, it may be possible to limit the repair to the actual components and areas of the transmission that have failed.

In this connection, please note:

- Never re-use throttle cables and seals, for example O-rings, shaft sealing rings, sealing sleeves or paper gaskets.
- If the transmission has been used for a considerable distance (> 50,000 km), renew all lined and steel plates.
- If clutch damage has occurred, the converter, oil cooler lines and the oil cooler itself must be thoroughly flushed out with a suitable cleaning agent.

The following conditions must be satisfied for effective repairs:

- The necessary special tools must be available.  
The complete set is listed in Section 1.8 of this manual.
- A suitable transmission test rig should be available.  
Refer to the Technical Bulletins for the relevant test values.

## NOTE:

In this manual the control unit is treated as a single element; it should not be dismantled except by suitably trained personnel possessing full knowledge of its design, but should always be exchanged as a complete unit.

## Warning:

The transmission should only be delivered with the oil content stated in the relevant component list (on microfiche).



## 1. General information

### 1.1 Drawing of transmission (similar version)

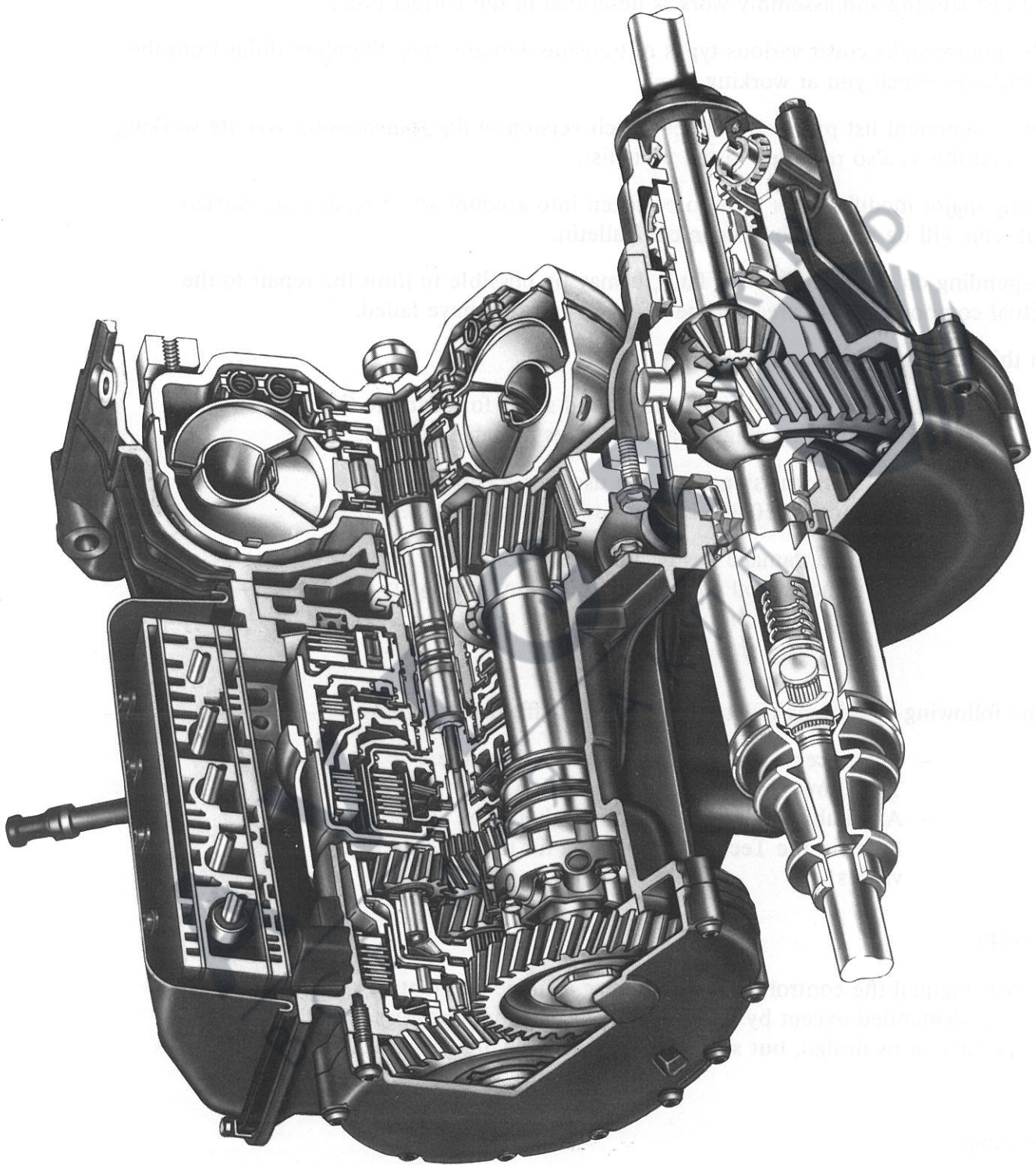

## 1.2 Power flow

### Gear

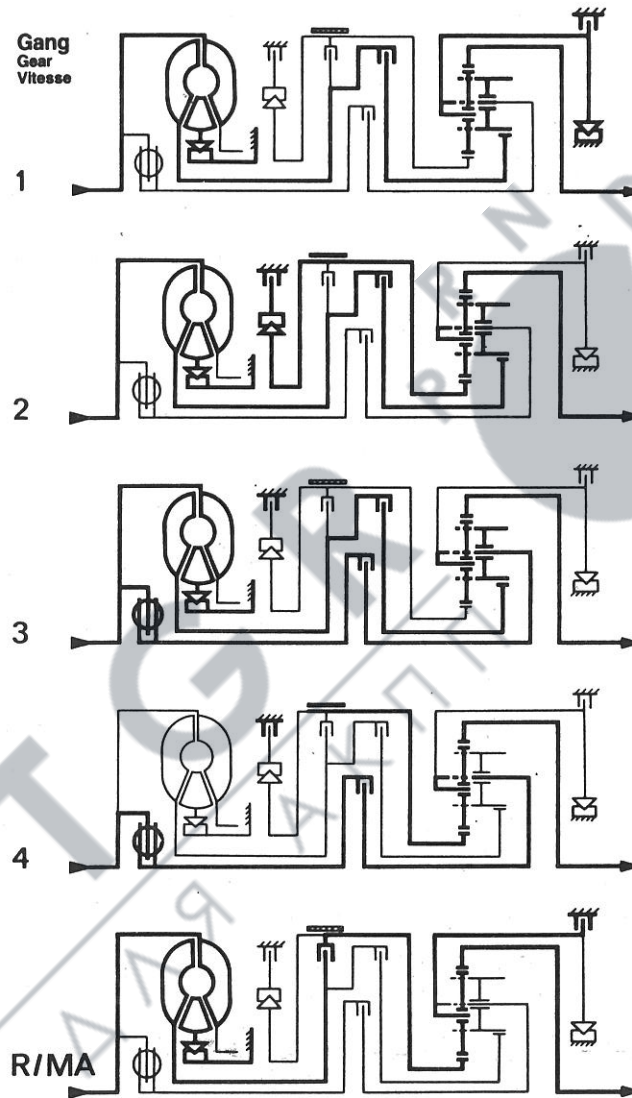

For a full description, refer to Technical Bulletin,  
File No. 401.3, Group 008/010, dated 22.10.84.

The power flows of the 4 HP 14 and 4 HP 18 are identical.





## 1.4 Adjustment work

### 1.4.1 Clearance in selector shaft mechanism (washer)

Bolt adjustment fixture 5 P 95000301 to the housing and press the cam against the locking cam teeth so that no clearance is present.

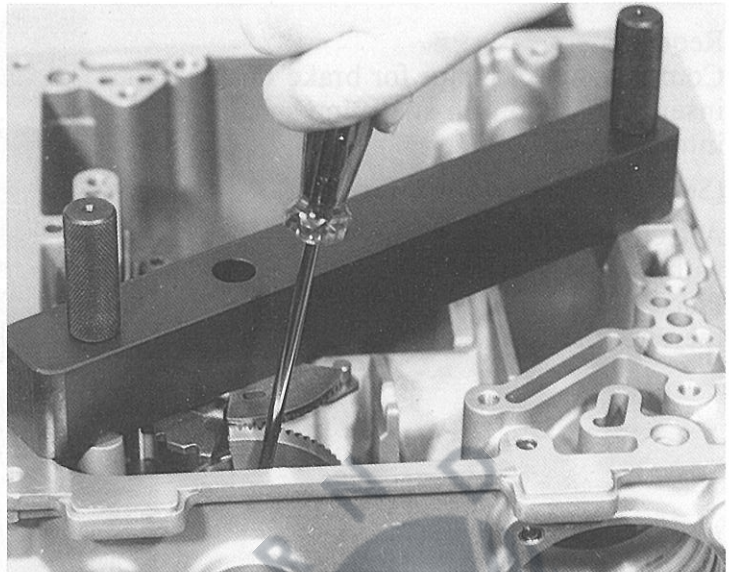

85216

Use a feeler gauge to determine distance X between housing and cam.

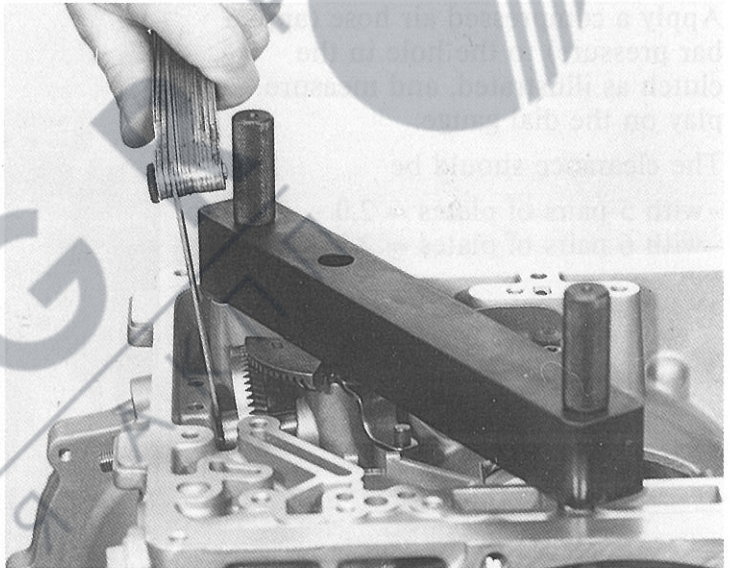

85217

Determine washer thickness according to the following formula:

$$S \text{ (mm)} = X \text{ (mm)} - 0,10 \text{ (mm)}$$

with S = washer thickness

X = value to be measured

0.10 = selected clearance

(0.10 – 0.20 acc. to component list)

Exemple:

X is measured with a feeler gauge.

$$X = 2.3 \text{ mm}$$

$$S = 2.3 \text{ mm} - 0.10 \text{ mm}$$

$$S = 2.2 \text{ mm}$$

In this example, two washers must be inserted to obtain the total thickness of S = 2.2 mm.

### 1.4.2 Clearance at brake D (snap ring)

85244

#### Requirements:

Complete set of plates for brake D inserted, 17.080 mm snap ring sprung into position.

(Selected thickness = 1.0 mm)

Attach measuring bar and dial gauge with extended feeler.

Place the point of the dial gauge on the end plate and set the gauge to 0.

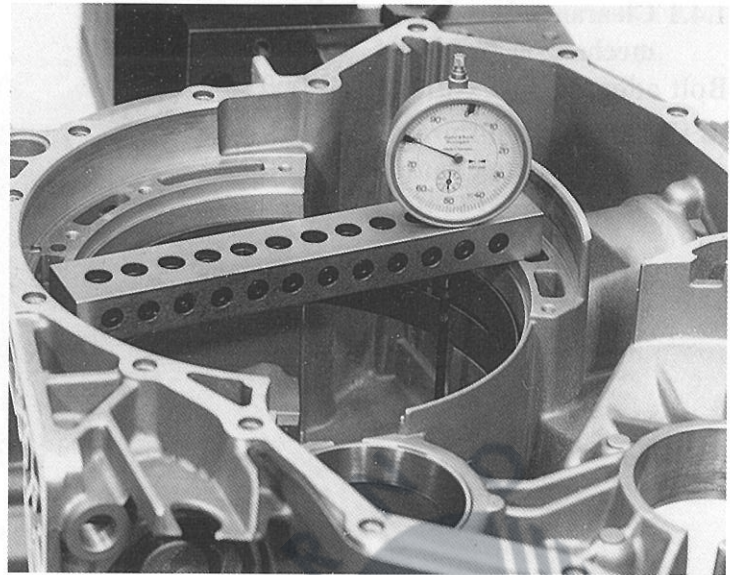

Apply a compressed air hose (app. 6 bar pressure) to the hole in the clutch as illustrated, and measure play on the dial gauge.

The clearance should be

- with 5 pairs of plates = 2.0 – 2.6 mm
- with 6 pairs of plates = 2.3 – 2.9 mm

90071

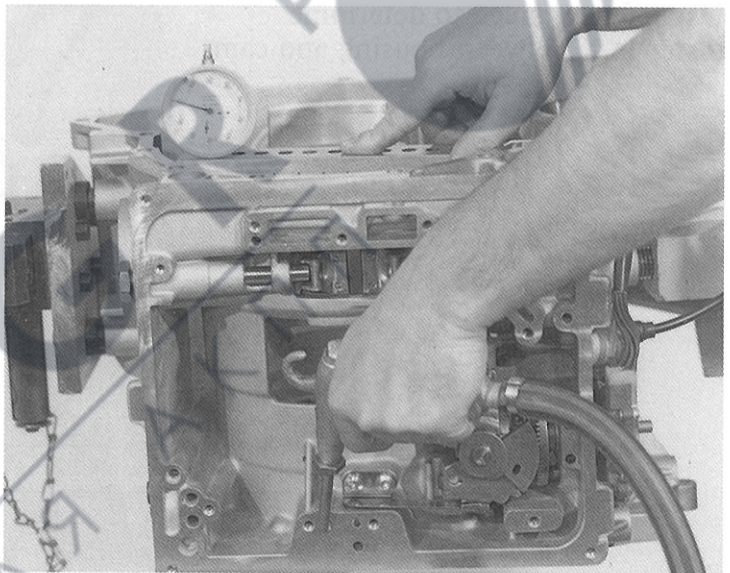

If the measured value is different, a thinner or thicker snap ring must be installed.

85236

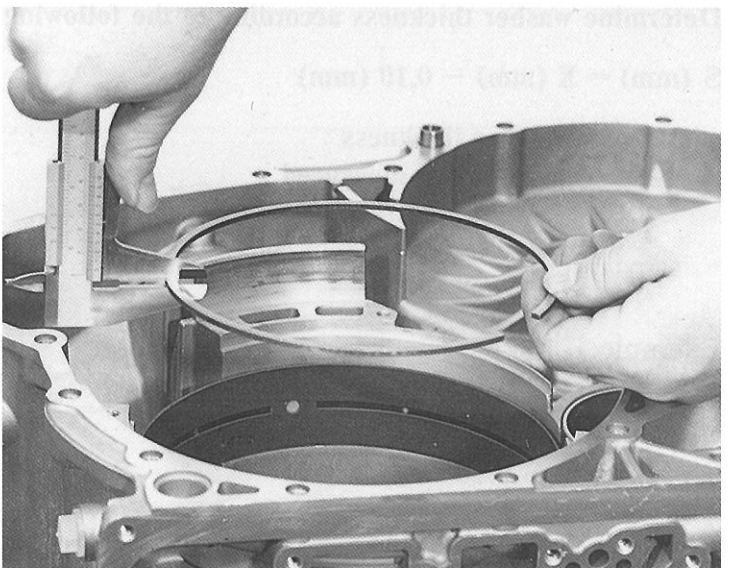



### 1.4.3 Clearance at clutch A (snap ring)

85271

Insert snap ring 02.060/200.

(Selected thickness = 1.0 mm)

Attach measuring bar with dial gauge.

Place the feeler of the dial gauge on the end plate and set the gauge to 0.

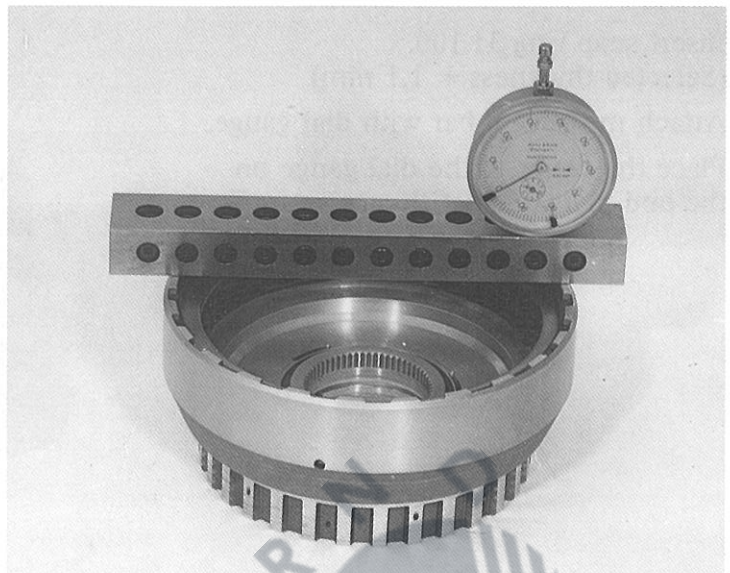

Raise the complete plate cluster and read off the play at the dial gauge.

The clearance should be

- with 4 pairs of plates = 1.8 – 2.0 mm

- with 5 pairs of plates = 2.3 – 2.5 mm

85272

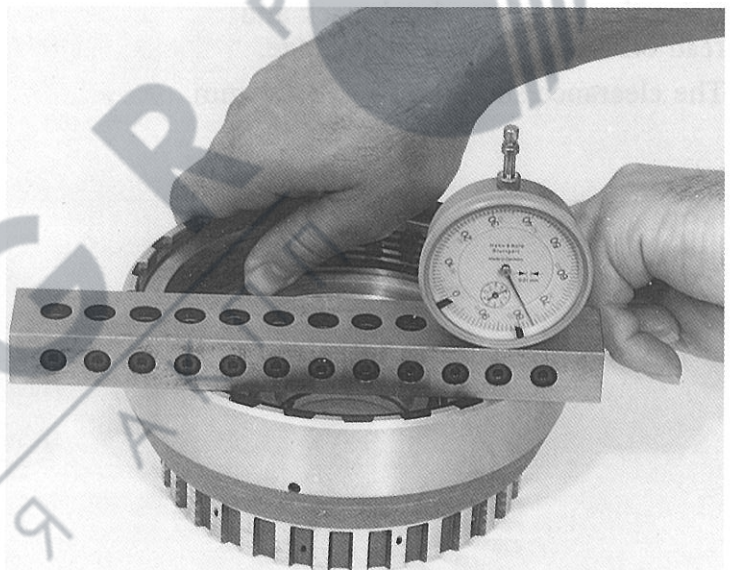

If the measured value is different, a thinner or thicker snap ring must be installed.

85273

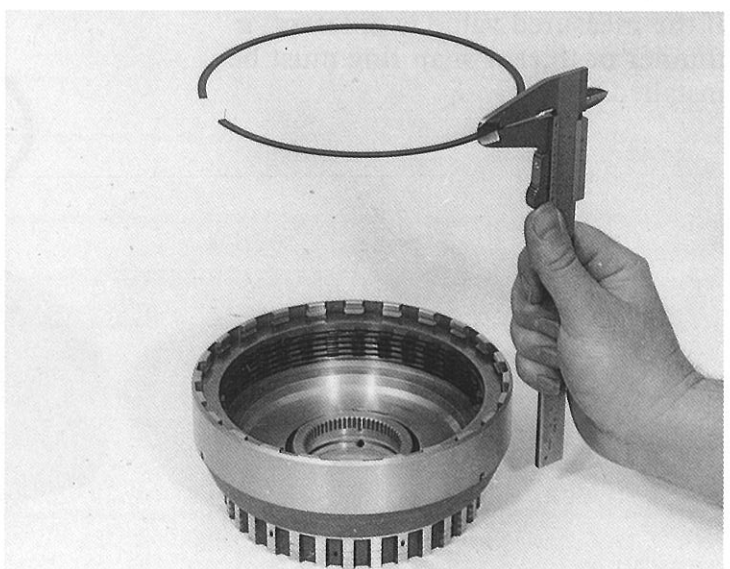

#### 1.4.4 Clearance at brake C (snap ring)

85 294

Insert snap ring 31.100.

(Selected thickness = 1.1 mm)

Attach measuring bar with dial gauge.

Place the feeler of the dial gauge on the end plate and set the gauge to 0.

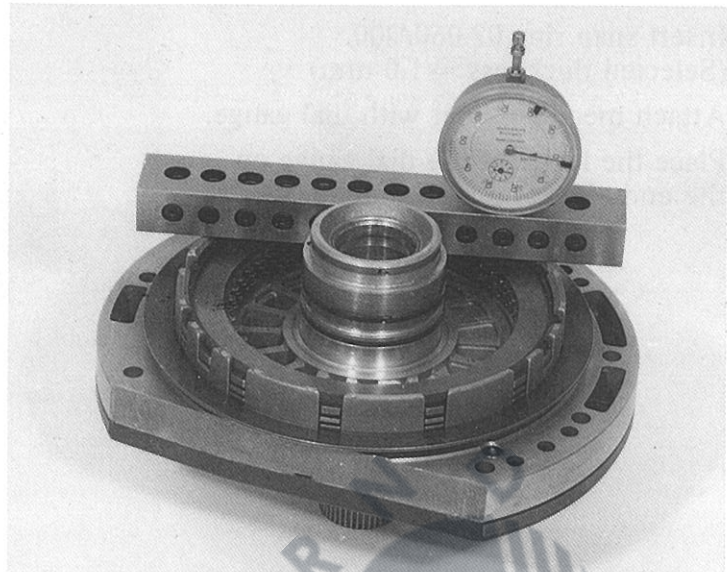

Raise the complete clutch pack and read off the play at the dial gauge.

The clearance should be 1.4 – 1.6 mm.

85 295

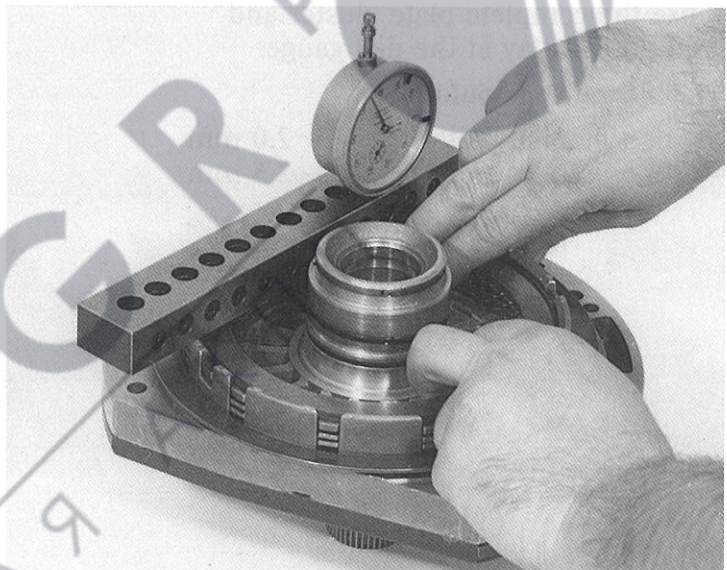

If the measured value is different, a thinner or thicker snap ring must be installed.

85 296

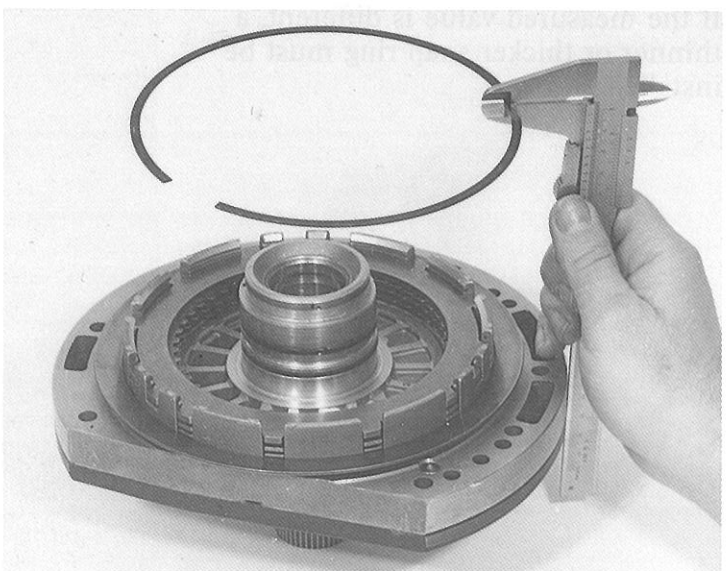



#### 1.4.5 Endplay (washer)

85 301

Place 22.090 washer (selected thickness 1.0 mm) and 22.080 angle washer on the hub of cylinder B.

(When measuring, do not install the 2nd gear freewheel).

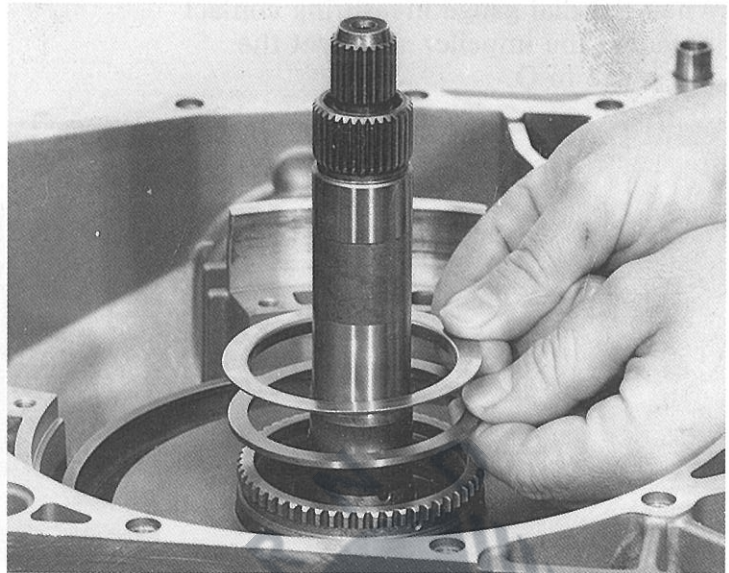

Insert the complete pump/intermediate plate assembly, turning it back and forward long enough for the plate spring of brake C to be abutting on the transmission housing and fit in place with 2 opposite cylindrical bolts.

(Tightening torque 10 Nm).

85 302

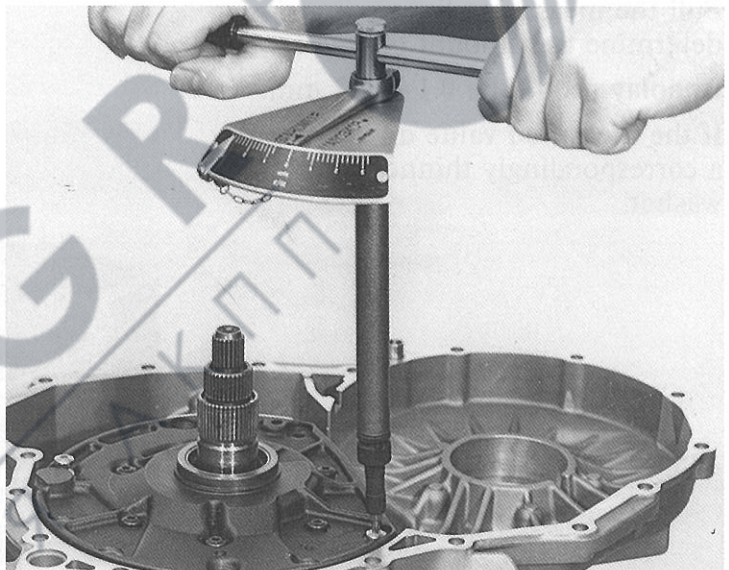

Attach measuring fixture 5 P 01 001 522 to the turbine shaft and clamp it on securely.

85 303

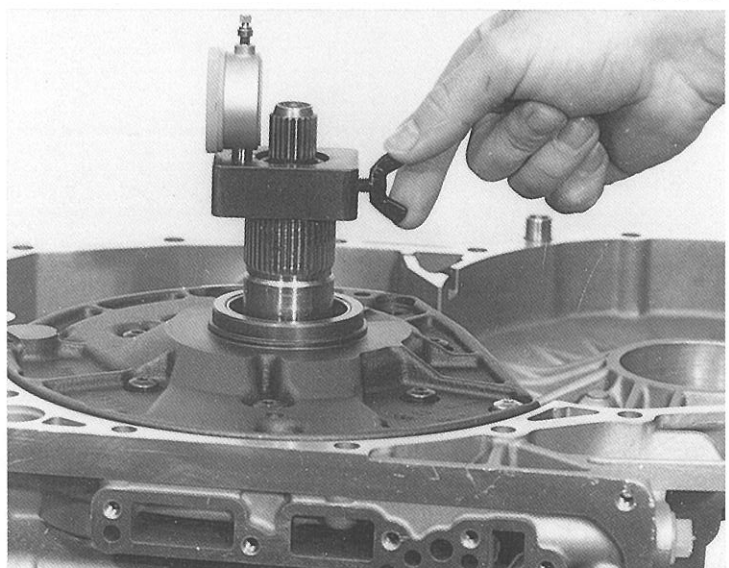

When the dial gauge measuring contact is against the impeller shaft, set the dial gauge to 0.

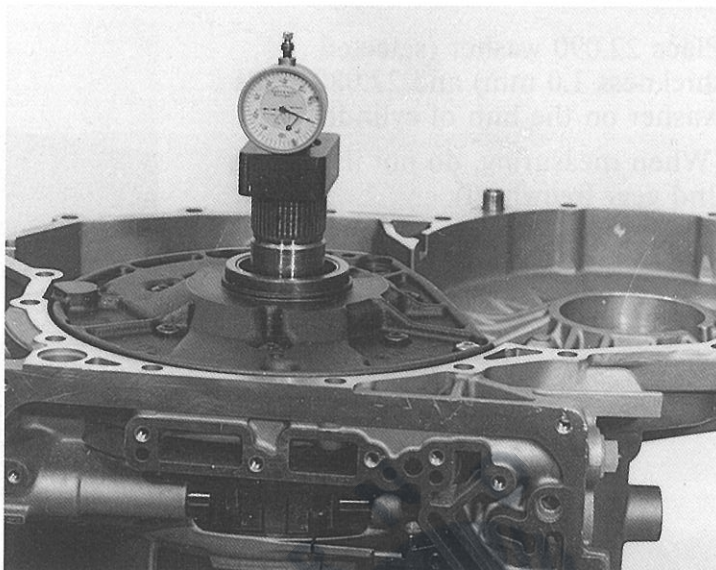

Pull the measuring fixture to determine the amount of endplay. Endplay should be 0.1 – 0.3 mm. If the measured value differs, insert a correspondingly thinner or thicker washer.

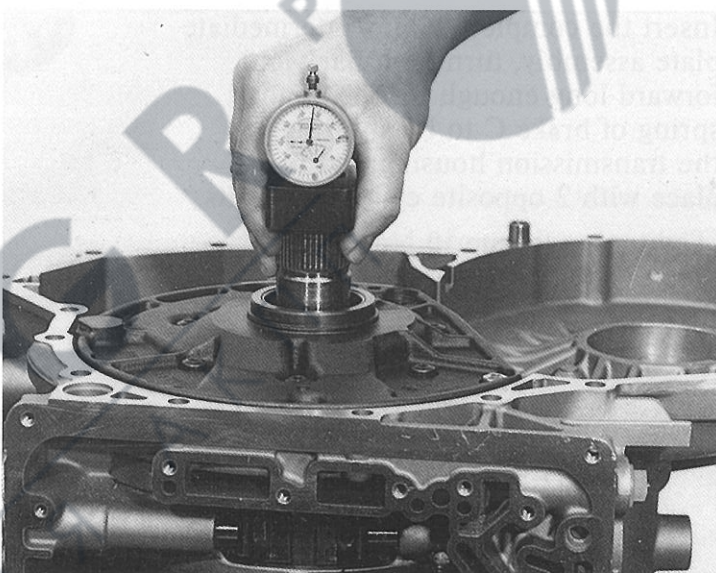



## 1.4.6 Spur gear drive

### 1.4.6.1 Output shaft preload (washer)

#### Important:

To avoid obtaining an incorrect reading, make quite sure that the 8 retaining bolts for the intermediate plate/pump on the opposite side are slackened off.

First place the 09.024 washer (selected the thickness 1.95 mm) and the correct spur gear on the side shaft, and screw up the bolt without tightening it yet.

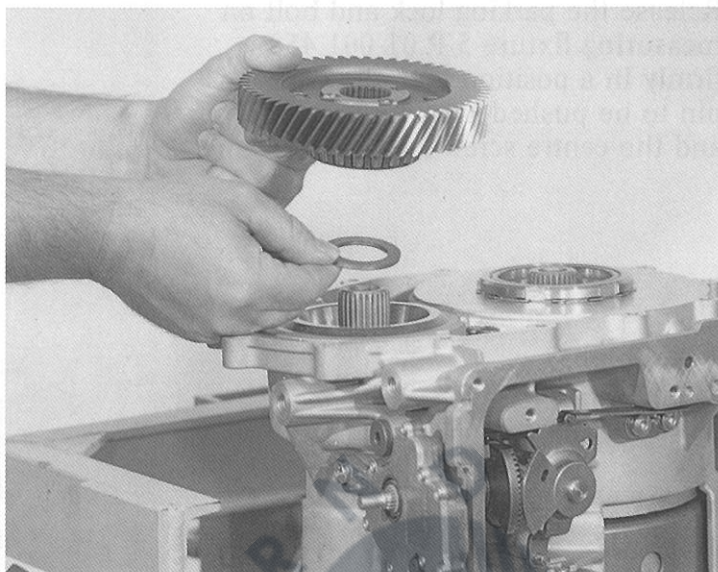

85332

Place the gauge ring of measuring fixture 5 P 01 001 458 on the inner race of the output shaft taper roller bearing.

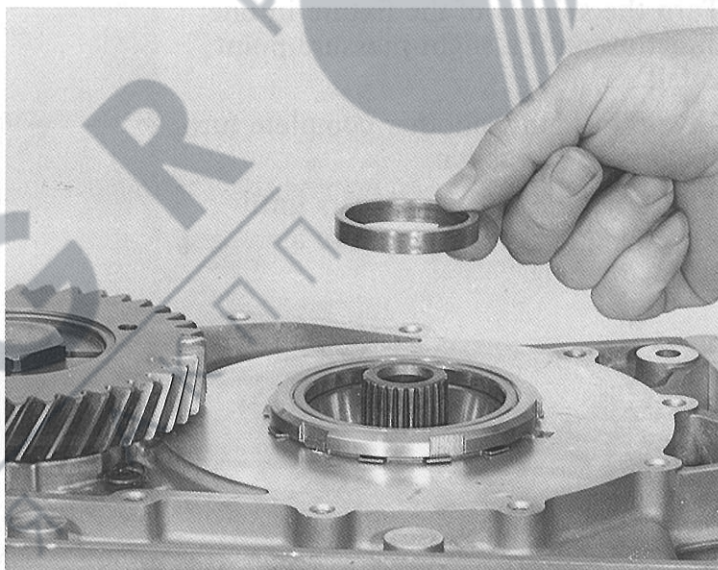

90085

Install the spur gear and tighten the screw of the measuring fixture to a torque of 150 Nm.

(Wrench size = 36 mm.)

Note that the parking lock must be engaged while this is done.

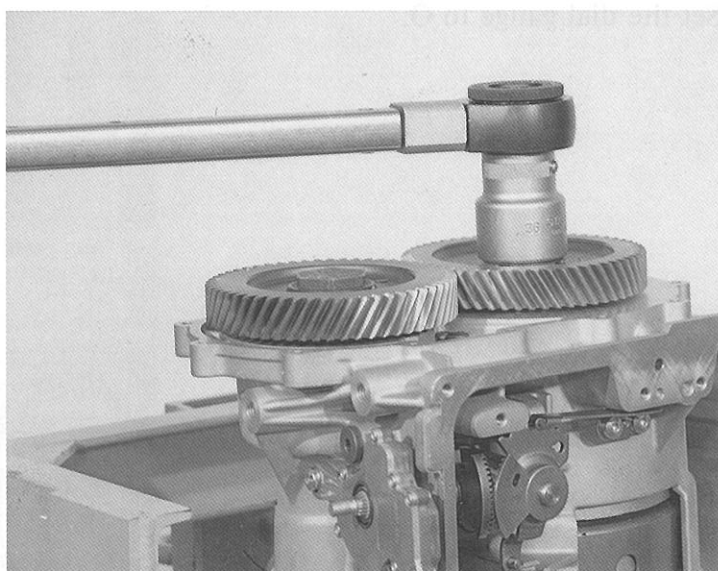



Release the parking lock and bolt on measuring fixture 5 P 01 001 458 firmly in a position that allows the pin to be pushed into the spindle loop and the centre screw at the same time.

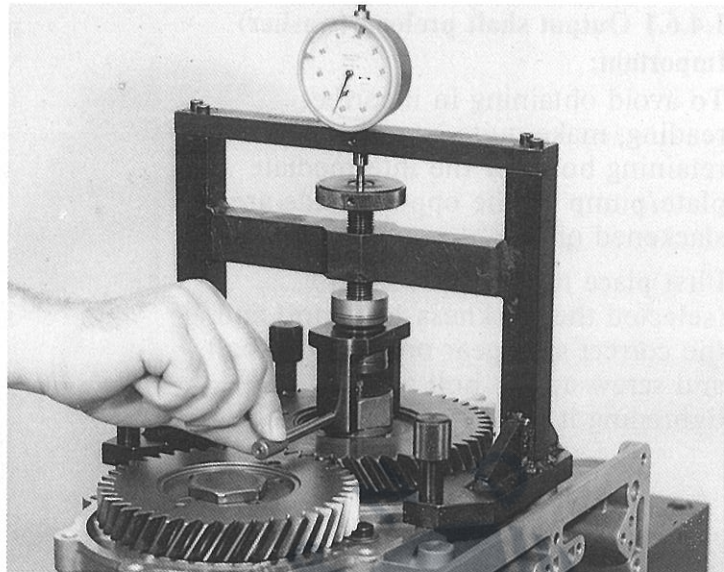

Turn the spindle of the fixture in one direction until a slight pressure point is felt.

Give the spindle another complete turn in the same direction.

After this, turn the spur gears until the dial gauge feeler settles to a steady reading.

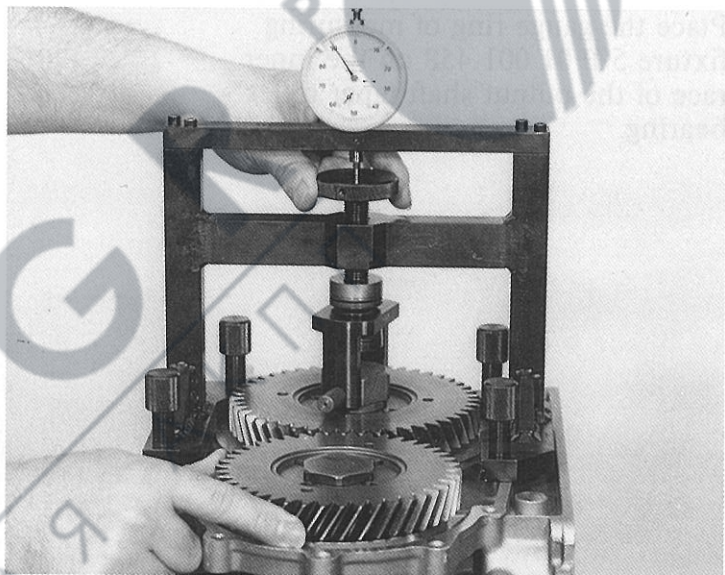

Set the dial gauge to 0.

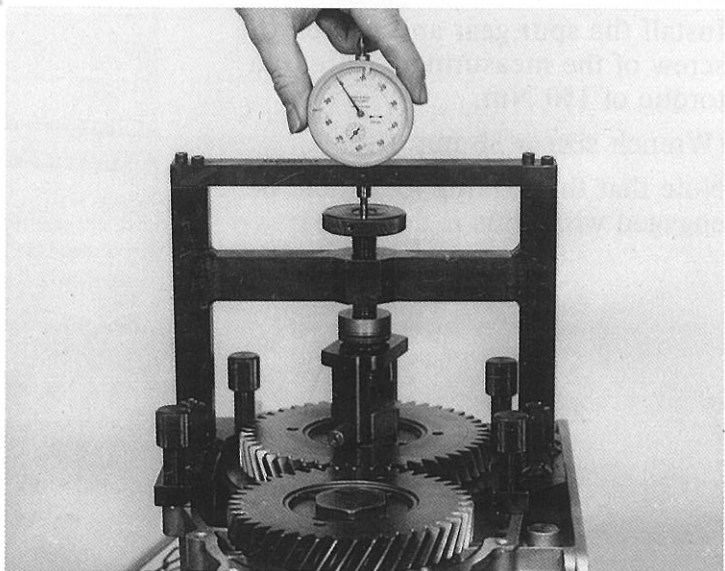

Now turn the spindle back the other way until a slight pressure point is again encountered.

Give it another complete turn.

Turn the spur gears until the dial gauge feeler settles to a steady reading.

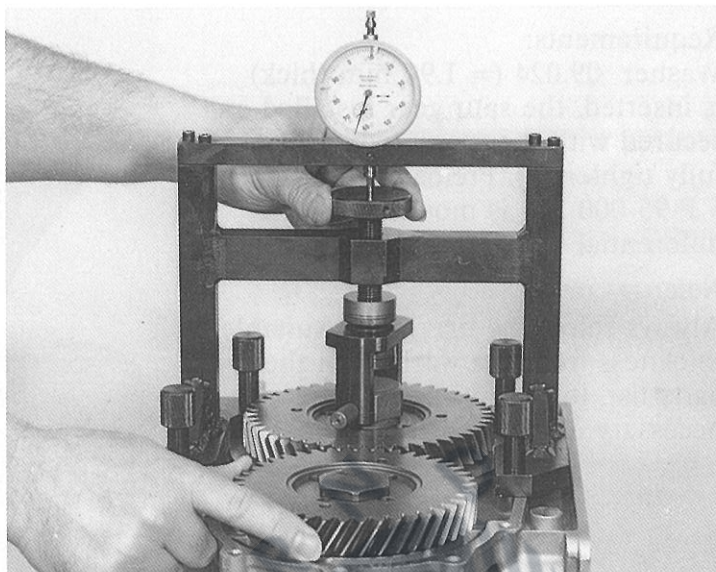

Read off value X at the dial gauge.  
For example: 0.65 mm.

**Important:**

Note the correct direction of dial gauge rotation.



**Determine washer thickness „S” according to the following formula:**

$$S \text{ (mm)} = (7 \text{ mm} - X \text{ mm}) - a \text{ (mm)}$$

with S = desired washer thickness

7.00 = thickness of gauge ring

X = value to be measured

a = 0.01 – 0.04 mm

(preload acc. to parts list)

Example:

$$S = (7.00 \text{ mm} - 0.65 \text{ mm}) - 0.03 \text{ mm}$$

$$S = 6.35 \text{ mm} - 0.03 \text{ mm}$$

$$S = 6.32 \text{ mm}$$

Select value „a” within the specified limits (preload) so that one of the available washer thicknesses from the parts list can be used.



#### 1.4.6.2 Side shaft clearance (washer)

85339

##### Requirements:

Washer 09.024 (= 1.90 mm thick) is inserted, the spur gear installed and secured with the screw (which is not fully tightened). Preload fixture 5 P 95 000 300 is mounted on the differential end of the side shaft.

##### Note:

Always select the maximum suitable thickness from the washers in the parts list, to ensure that the necessary clearance is maintained.

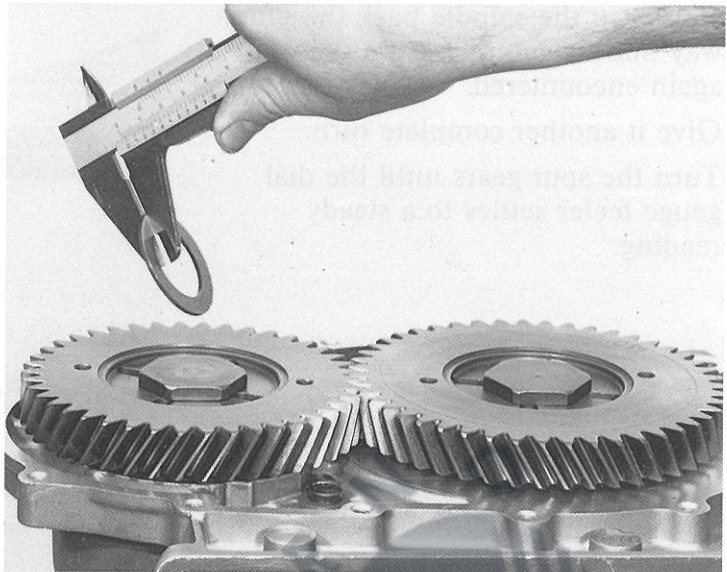

Engage the parking lock and tighten the screw to a torque of 150 Nm. Release the parking lock.

(Wrench size = 36 mm.)

85340

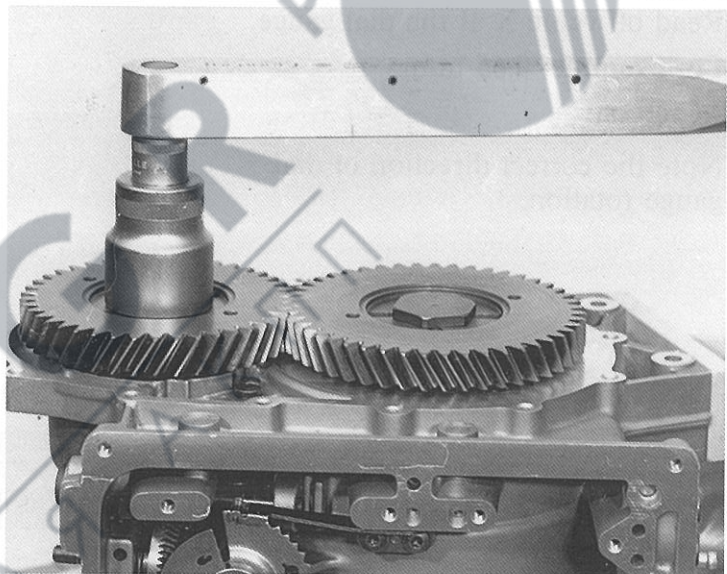

Screw on measuring fixture 5 P 01 001 523 with dial gauge.

90086

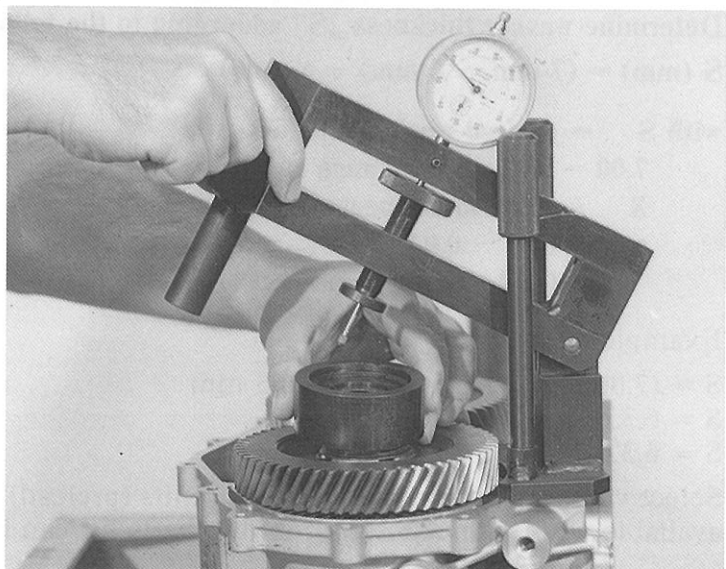



Set the dial gauge to 0 after having turned the spur gears at least 10 times to obtain a consistent value.

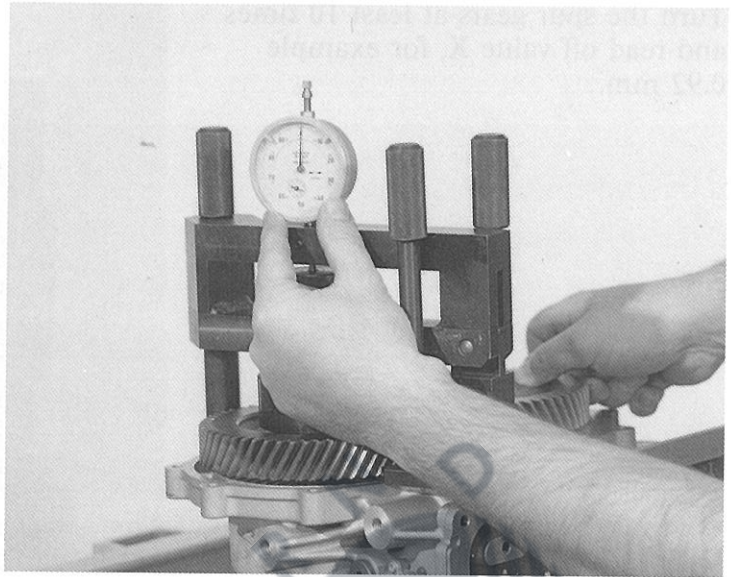

Detach preload fixture 5 P 90 000 300 from the underside of the transmission, then lower by turning the spindle adjusting screw until slight resistance is felt.

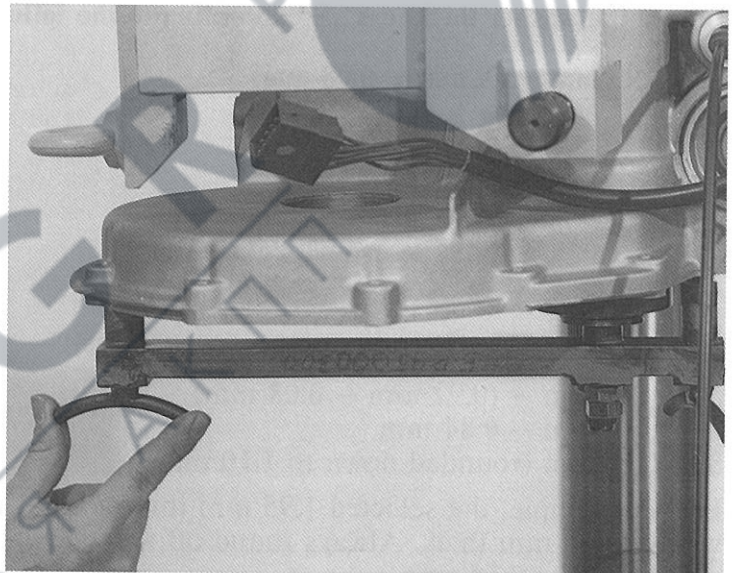

Lower the spindle adjusting screw by another full turn.

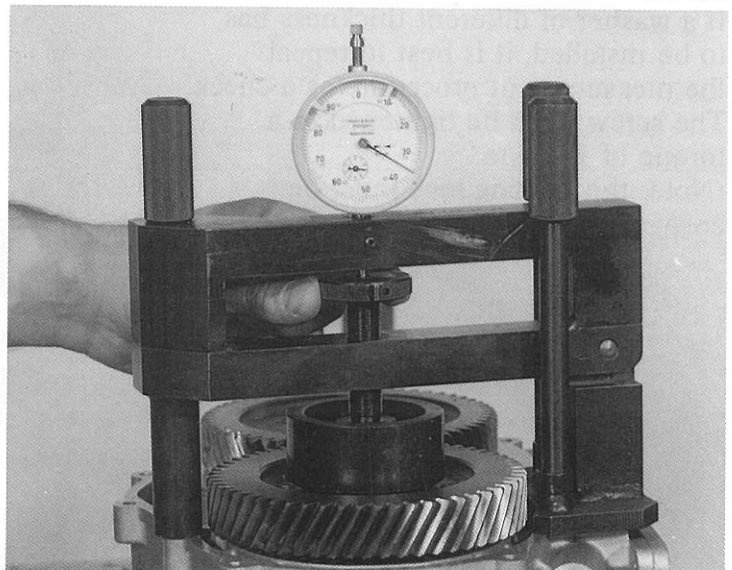

Turn the spur gears at least 10 times and read off value X, for example 0.92 mm.

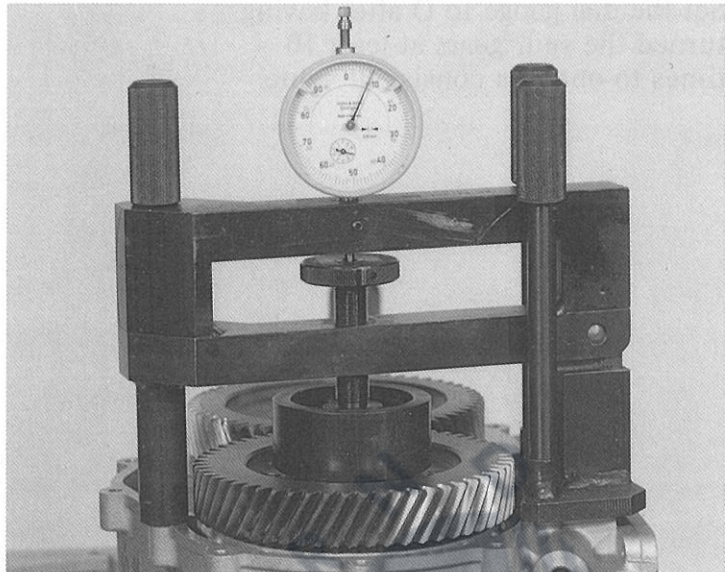

Determine washer thickness „S” according to the following formula:

$$S = 1.95 \text{ mm} - (X \text{ mm} - 0.08 \text{ mm})$$

with S = desired washer thickness  
 X = measured value  
 0.08 = selected clearance  
 (according to component list)

Example:

$$S = 1.95 \text{ mm} - (0.92 \text{ mm} - 0.08 \text{ mm})$$

$$S = 1.95 \text{ mm} - 0.84 \text{ mm}$$

$$S = 1.11 \text{ mm (rounded down to 1.10 mm)}$$

In this example, the selected 1.95 mm thick washer must be replaced by a washer 1.10 mm thick. Always round off the calculated value to the nearest actual washer thickness.

If a washer of different thickness has to be installed, it is best to repeat the measurement procedure as a check. The screw must be tightened to a torque of 150 Nm.  
 (Note: the parking lock must be engaged while tightening.)

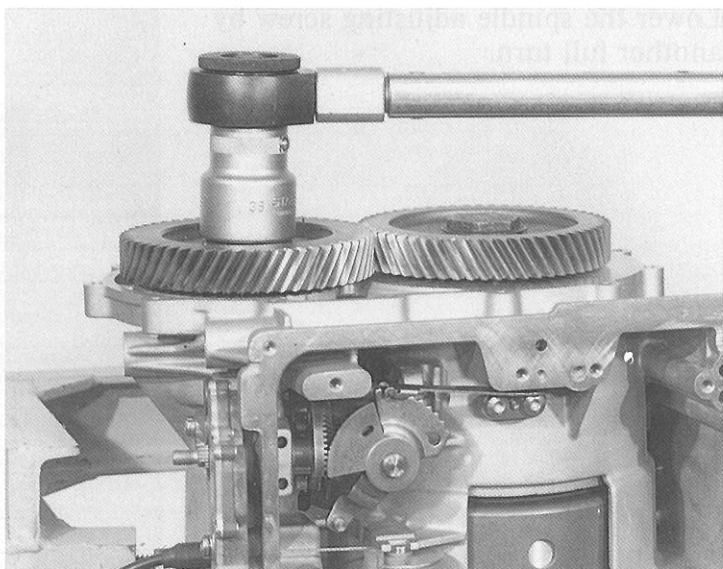



### 1.4.7 Differential preload (washer)

90115

Determine distance B on the extension.

Example: distance B = 9.90 mm.

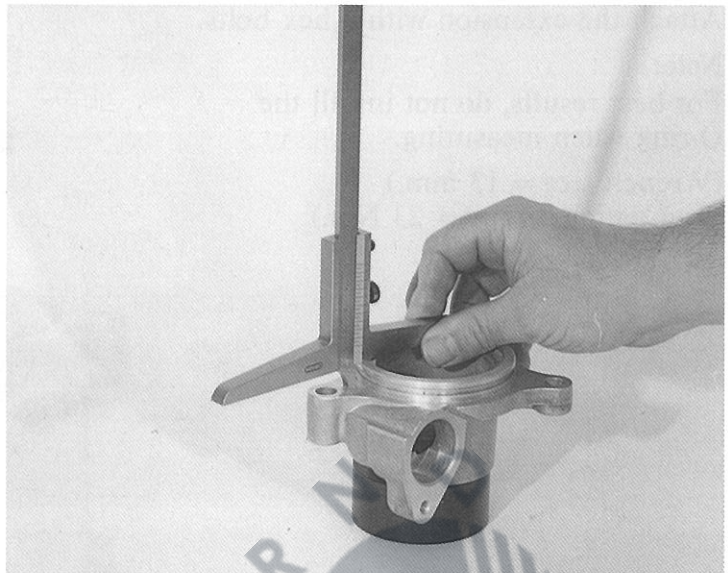

Measure distance A between the machined face on the bell-housing and the outer race of the taper roller bearing.

Example: distance A = 10.10 mm

Determine bearing play.

**Play = distance A - distance B**

Example:

Play = 10.10 - 9.90 mm = 0.20 mm



90116

To ensure that the outer race of the taper roller bearing is pressed against the inner race, increase washer thickness by 0.50 mm.

Distance X is thus obtained as follows:

**X = distance A - distance B + 0.50 mm**

Example:

X = 10.10 mm - 9.90 mm + 0.50 mm  
= 0.70 mm.



90117



Attach the extension with 3 hex bolts.

**Note:**

For best results, do not install the O-ring when measuring.

(Wrench size = 13 mm.)

(Tightening torque = 23 Nm.)

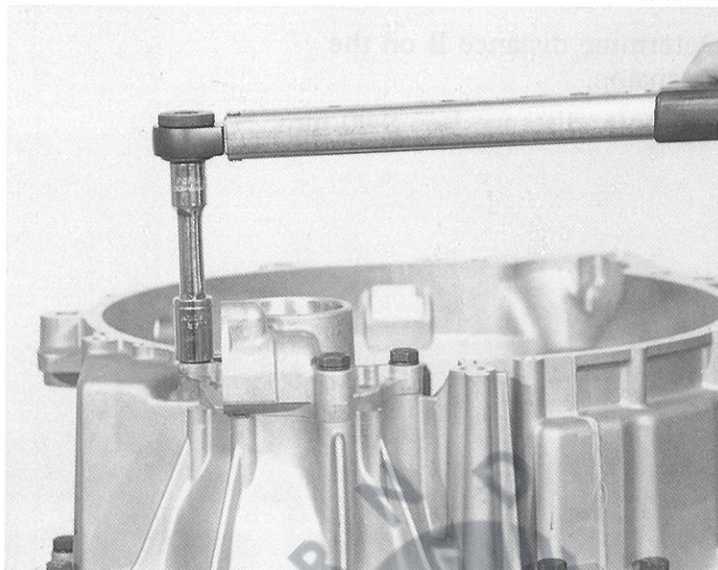

Give the retaining screw at least 10 turns to bed down the taper roller bearing.

(Wrench size = 36 mm.)

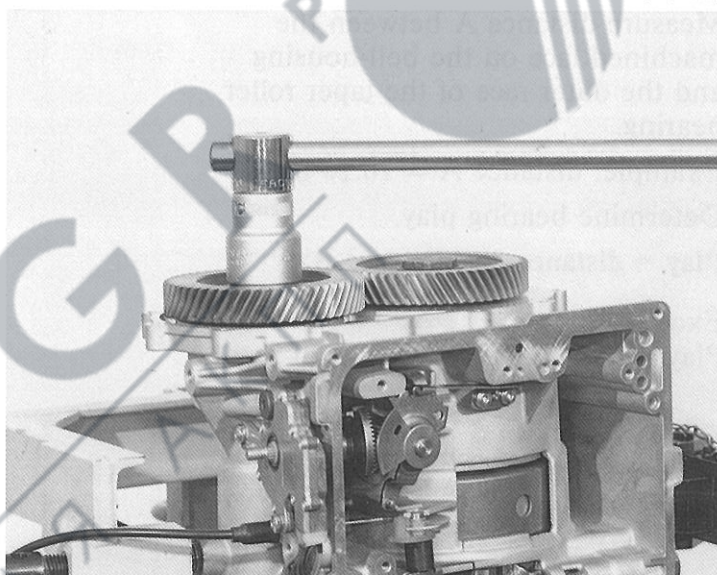

Remove the 3 hex bolts again and measure gap H with a feeler gauge. For example: 0.40 mm.



Determine washer thickness „S” according to the following formula:

$$S \text{ (mm)} = X \text{ (mm)} - H \text{ (mm)} + V \text{ (mm)}$$

Key:

S (mm) = required washer thickness

X (mm) = distance A - distance B + 0.50 mm (0.50 mm = additional washer thickness)

H (mm) = clearance (determined with feeler gauge)

V (mm) = preload according to component list = 0.10 – 0.15 mm

Example:

$$S \text{ (mm)} = 0.70 \text{ mm} - 0.40 \text{ mm} + 0.10 \text{ mm}$$

X = 0.70 mm = 10.10 mm – 9.90 mm + 0.50 mm

H = 0.40 mm (measured with feeler gauge)

V = 0.10 mm (preload, selected within the permissible limits)

S = 0.40 mm

Round off calculated washer thickness S to the nearest washer thickness available in the parts list.

Insert the selected washer(s).

Example:

Insert a washer 0.40 mm thick.

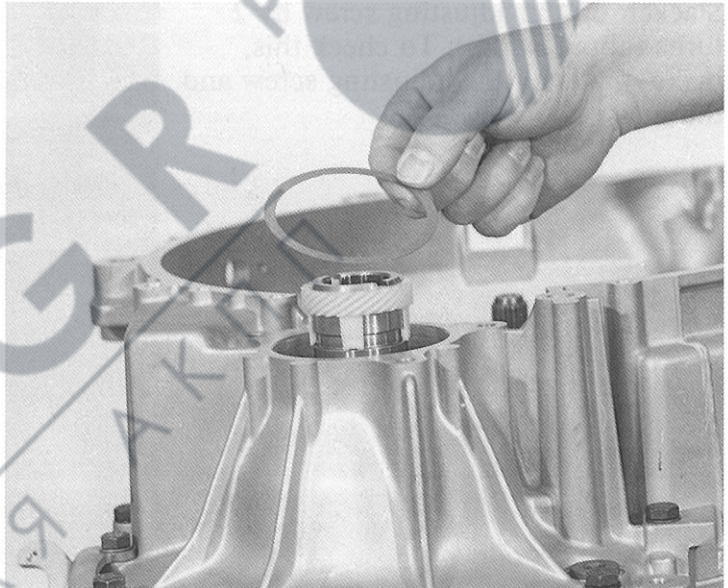

90121



#### 1.4.8 Brake band (tightening torque)

90 127

Apply a thin coat of ATF (automatic transmission fluid) to cylinder B. Tighten the adjusting screw to a torque of 10 Nm.

(Wrench size = 6 mm Allen key.)

**Important:**

While tightening, turn cylinder B to prevent the brake band from tilting.

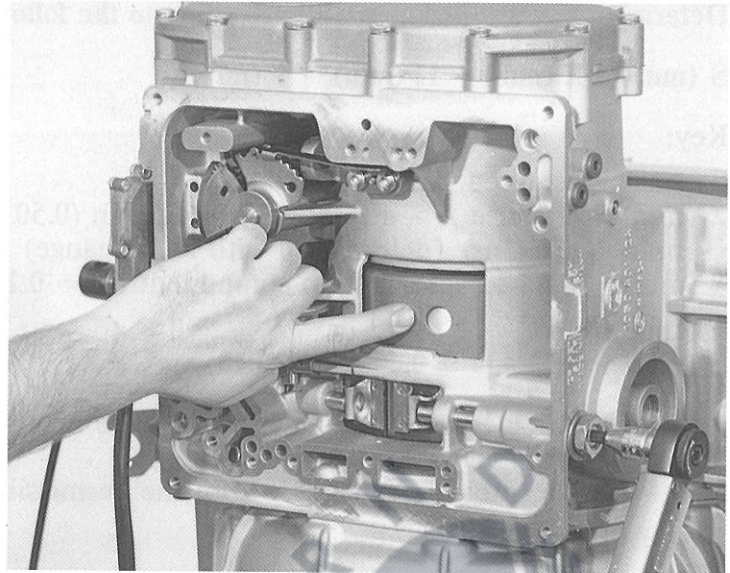

Slacken off the adjusting screw by 2 turns (about 3 mm). To check this, make marks on the adjusting screw and the housing.

90 128

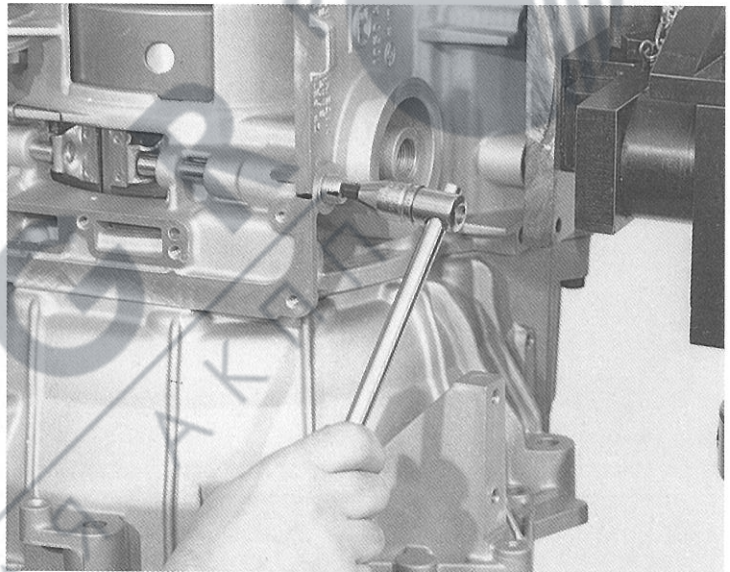

Tighten the locknut to a torque of 60 Nm.

(Wrench size = 22 mm.)

90 129

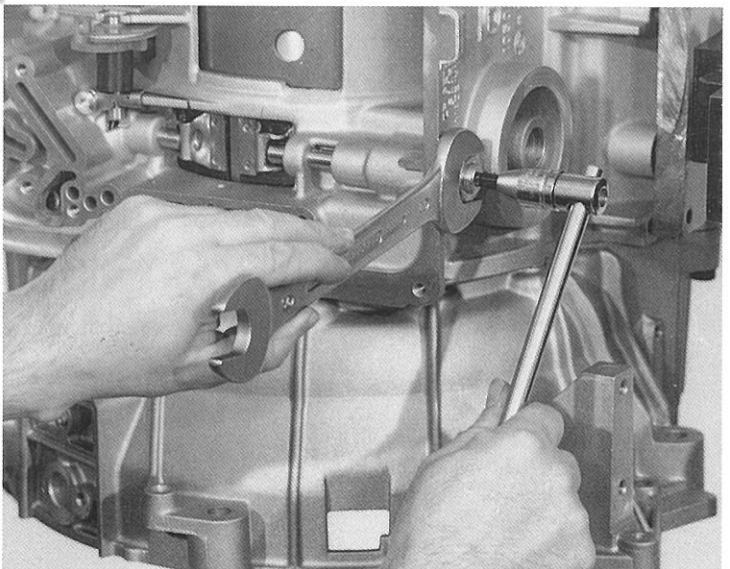



### 1.4.9 Throttle cable setting (full throttle)

85398

With the outer sleeve fully stretched, pull the throttle cable out as far as the kick-down stop (definite resistance is felt at this point).

Clamp the led seal on X mm from the end of the wire.

Refer to the „Technical Cover Sheets” of the individual parts lists (microfiches) for adjustment distance 'C'.

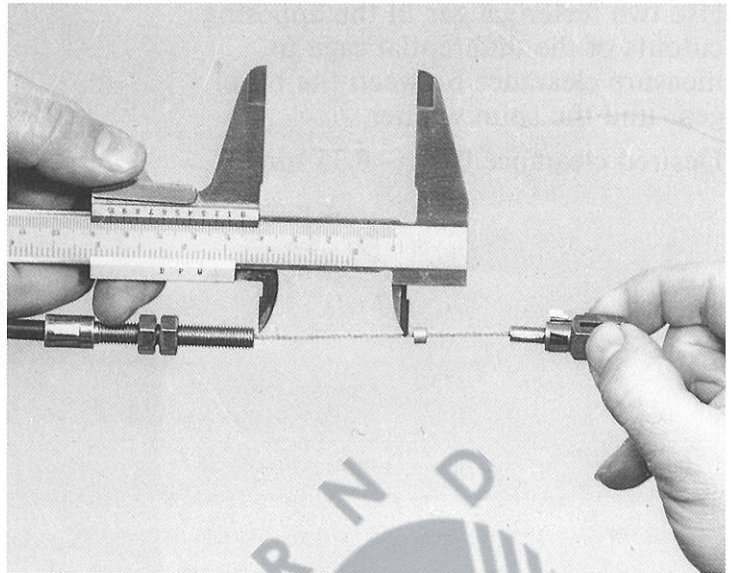

### 1.4.10 Checking position switch

Requirement:

Position switch must be accurately located with adjusting lever 0501 311 626.

Insert the cable in position switch tester 5 P 81 000 038.

Use an ohmmeter to check every position (P-1) according to the cart.

(STROMKREIS = CIRCUIT)  
(NICHT BELEGT = NOT IN USE)

ZP	STROMKREIS 1					STROMKREIS 2		STROMKREIS 3	
	1	2	3	4	5	6	7	8	9
PIN	+	X	Y	Z		+		+	
P	*	*			NICHT BELEGT	*	*		
R	*	*	*					*	*
N	*		*			*	*		
D	*		*	*					
3	*	*	*	*					
2	*	*		*					
1	*			*					

### 1.4.11 Adjusting differential (clearance)

Requirements: shim washer 09.090/136 (removed), bevel gear 09.090/140, the four differential gears 09.090/160 with thrust washers 09.090/170 and differential spider 09.090/210 are installed with pins 09.090/180 and 09.090/200 in differential cage 09.090/110.

(See also pages 95 and 96 of this manual).

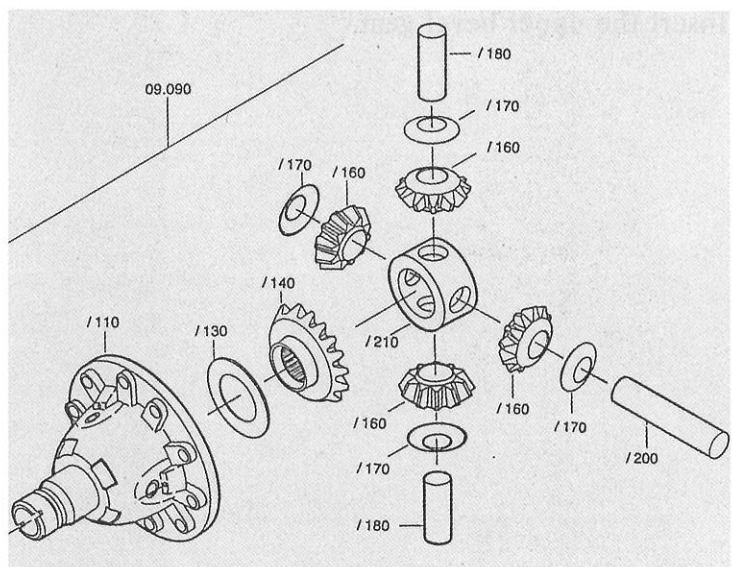



Use two feeler gauges in the opposing cutouts of the differential cage to measure clearance between the bevel gear and the shim washer.

Desired clearance 0.25 – 0.35 mm.

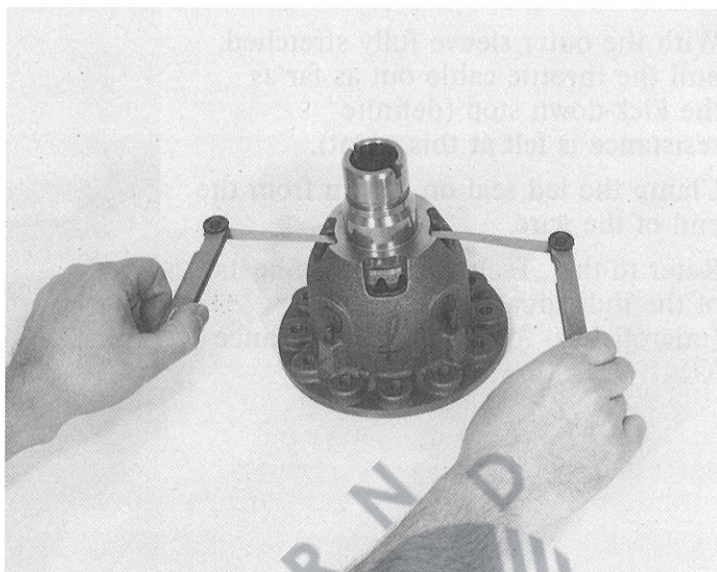

If the value is not as stated, install a thicker or thinner shim washer to compensate for the difference.

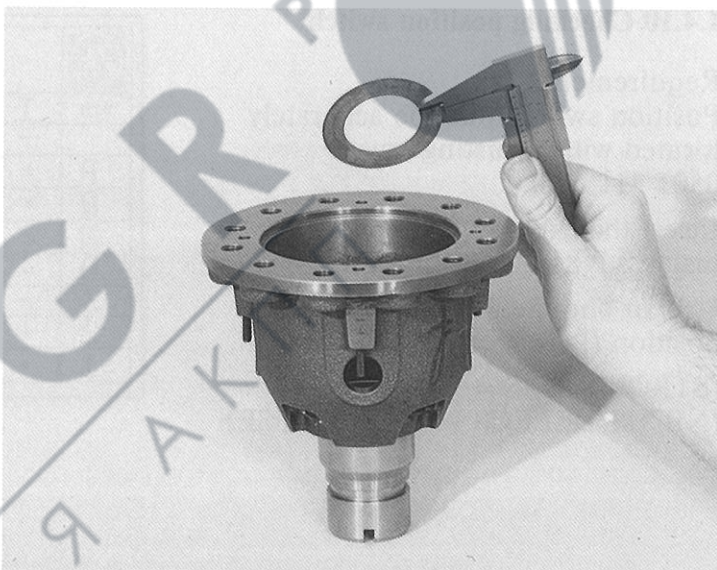

Insert the upper bevel gear.

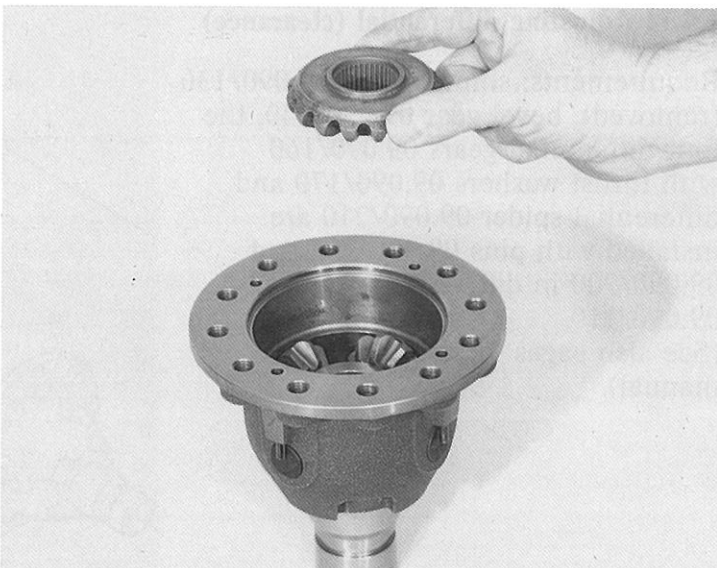



Using a depth gauge, determine distance A between the contact face on the differential cage and the bevel gear.

Example: distance A = 21.5 mm.

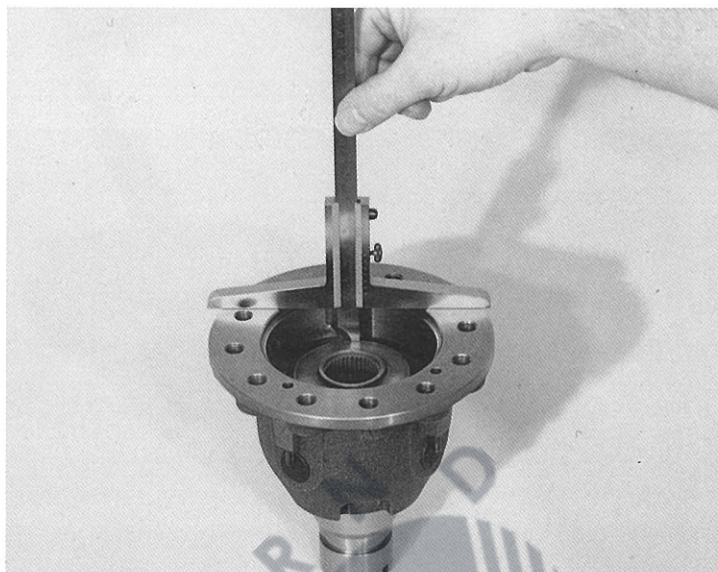

In the same way, determine distance B between the contact face and the hub of the differential cover.

Example: distance B = 20.5 mm.

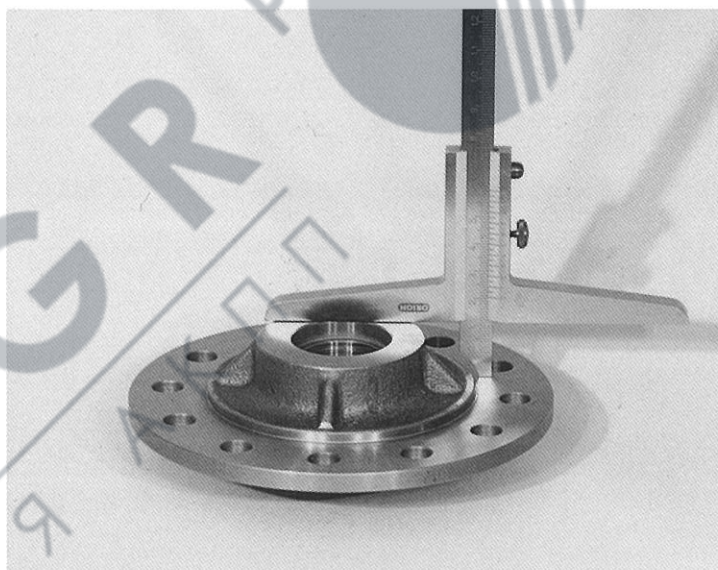

**Determine washer thickness S as follows:**

$S = A - B$  — measured clearance

**Example:**

$S = 21.5 \text{ mm} - 20.5 \text{ mm} - (0.25 - 0.35)$   
 $S = 0.65 \text{ mm} - 0.75 \text{ mm}$

Install a washer of the thickness determined in this way.

For remainder of assembly procedure, see Page 97.

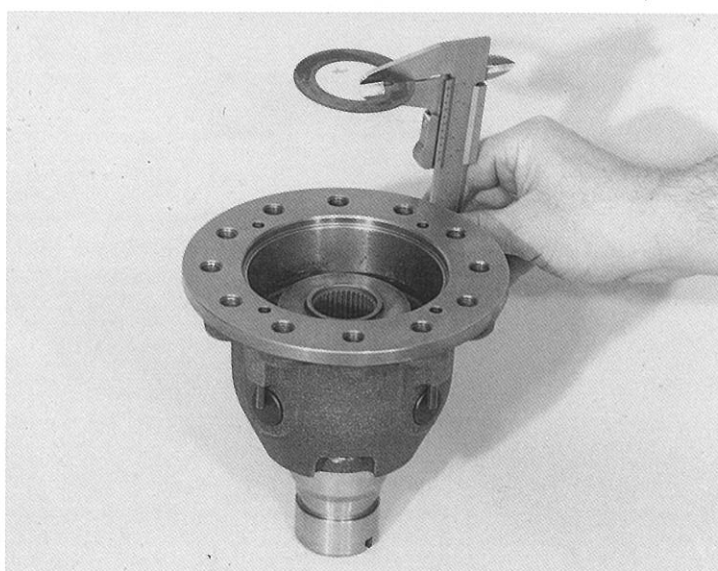

**AVTGR**  
ВСЕ ДЛЯ АКПП



## 1.5 Tightening torques

Item	Wrench size	See page	Tightening torque
Screw plug (transmission housing)	5 mm Allen screw	46	15 Nm
Machine screw (pawl pin)	TORX-TX 27	48	10 Nm
Screw plug (parking lock)	6 mm Allen screw	50	32 Nm
Machine screw (detent spring)	TORX-TX 27	51	10 Nm
Machine screw (position switch)	TORX-TX 27	53	10 Nm
Machine screw (shift components)	TORX-TX 27	54	10 Nm
Slotted nut	5X46 000 155	62	50 Nm
Machine screw (int. plate, pump)	TORX-TX 27	81	10 Nm
Machine screw (gvrnr hsg., flange)	TORX-TX 27	89	10 Nm
Screw (output shaft/side shaft)	36 mm hex	92	
<b>Caution:</b> adjustment work		5/12	150 Nm
Machine screw (intermediate plate, transmission housing)	TORX-TX 27	93	10 Nm
Locking screw (diff. spur gear)	17 mm hex	97	77 Nm
Screw plug (bell-housing)	8 mm Allen screw	98	45 Nm
Hex bolt (bell-housing)	13 mm hex	99	23 Nm
Hex bolt (extension)	13 mm hex	101	23 Nm
Machine screw (end cover)	TORX-TX 27	102	10 Nm
Machine screw (tube)	TORX-TX 27	103	5 Nm
Machine screw (control unit)	TORX-TX 27	106	8 Nm
Hex bolt (oil pan)	10 mm hex	107	6 Nm
Breather	Special wrench 5X46 000 615	108	5 Nm
Hollow screw (oil cooler)	27 mm hex	108	60 Nm
Hollow screw (oil cooler pipe)	19 mm hex	108	50 Nm
Machine screw (oil strainer cover)	TORX-TX 27	109	8 Nm

**AVTGR**  
ВСЕ ДЛЯ АКПП





## 1.6 TROUBLESHOOTING AUTOMATIC TRANSMISSION 4 HP 14/18

### PREFACE

The following troubleshooting table for the ZF 4 HP 14/18 automatic transmission is intended to be an aid in determining a diagnosis.

The faults listed have been written in the form in which they are generally presented by customers. The description which you are given may vary from this and it is up to the Service Engineer to interpret it accordingly.

If complaints are received regarding troublesome leaks, we recommend determining exactly where the leak is occurring before starting the job of sealing. There are suitable crack testing agents available such as

Met-L-Chek

This product is available from the trade in spray form and enables the leak point to be precisely located after a short test run.

#### Operational requirements

- Correct oil level
- Correct adjustment of accelerator cable:
  - Zero load: Lead seal 0,5 mm from sleeve
  - Full throttle: Lead seal 39,0 mm from sleeve
  - Kick-down: Lead seal 43,5 mm from sleeve
- Position indicator ok

# Troubleshooting the 4 HP 14/18 automatic transmission

Fault	Possible cause	Remedy
<p><b>1. Position P</b></p> <p>1.1 Park position does not engage or slipping</p>	<ul style="list-style-type: none"> <li>- Selector linkage or cable incorrectly adjusted</li> <li>- Clearance at stop plate too large</li> <li>- Segment installed incorrectly</li> <li>- Excessive friction in the parking interlock mechanism</li> </ul>	<ul style="list-style-type: none"> <li>- Correct setting</li> <li>- Correct setting</li> <li>- Install the correct way round</li> <li>- Examine parts (for dirt and burrs); replace if necessary</li> </ul>
<p>1.2 Engine does not start</p>	<ul style="list-style-type: none"> <li>- Starter interlock switch faulty</li> <li>- Excessive clearance at selector shaft</li> </ul>	<ul style="list-style-type: none"> <li>- Replace starter interlock switch</li> <li>- Correct setting</li> </ul>
<p><b>2. Position R</b></p> <p>2.1 No Reverse</p>	<ul style="list-style-type: none"> <li>- Selector linkage or cable between lever and transmission incorrectly adjusted</li> <li>- Oil strainer dirty</li> <li>- Clutch B damaged</li> <li>- Brake D damaged In this case no engine braking action in Pos. 1, 1. gear</li> <li>- Governor jammed (locking valve 1 and Reverse pushed)</li> <li>- Locking valve 1 and Reverse jammed</li> </ul>	<ul style="list-style-type: none"> <li>- Correct setting</li> <li>- Replace oil strainer</li> <li>- Replace transmission</li> <li>- Replace transmission</li> <li>- Replace governor cpl. or control unit</li> <li>- Replace control unit</li> </ul>
<p>2.2 Slipping or vibration when moving off</p>	<ul style="list-style-type: none"> <li>- Clutch B or brake D damaged</li> <li>- Leak in oil feed of clutch B (rectangular rings on intermediate plate)</li> </ul>	<ul style="list-style-type: none"> <li>- Replace transmission</li> <li>- Replace transmission</li> </ul>

## Troubleshooting the 4 HP 14/18 automatic transmission

Fault	Possible cause	Remedy
<p>2.3 Hard engaging jerk P-R or N-R Double jerk when engaging from P-R or N-R <math>n_{eng}</math> 1500 rpm</p>	<p>– Damper D faulty In this case shift pos. 2-1 not ok</p>	<p>– Replace control unit</p>
<p>2.4 Reversing lamp does not come on, electrics ok</p>	<p>– Starter interlock switch faulty</p>	<p>– Replace starter interlock switch</p>
<p><b>3.1 Position N</b> Engine does not start</p>	<p>– Starter interlock switch faulty</p>	<p>– Replace starter interlock switch</p>
<p>3.2 Vehicle moves or creeps forward</p>	<p>– Selector linkage or cable between selector lever and transmission incorrectly adjusted</p>	<p>– Correct setting</p>
<p><b>4. Position D</b> 4.1 No power</p>	<p>– Converter relief valve open – Oil strainer dirty – Clutch A faulty – 1. gear freewheel slipping – Selector linkage or cable incorrectly adjusted – Cable valve 3–4 jammed</p>	<p>– Replace transmission – Replace oil strainer – Replace transmission – Replace transmission – Correct setting – Replace control unit</p>

# Troubleshooting the 4 HP 14/18 automatic transmission

Fault	Possible cause	Remedy
<p>4.2 Slipping or vibration when moving off</p>	<ul style="list-style-type: none"> <li>- Clutch A damaged</li> <li>- Rectangular ring or O-ring on turbine shaft damaged (seal of oil feed of clutch A)</li> <li>- or O-rings of piston A damaged (also 4 HP 14)</li> </ul>	<ul style="list-style-type: none"> <li>- Replace transmission</li> <li>- Replace transmission</li> </ul>
<p>4.3 Hard engaging jerk N-D (<math>n_{eng}</math> 1500 rpm)</p>	<ul style="list-style-type: none"> <li>- Damper A jammed or spring broken</li> <li>- Clutch A damaged</li> <li>- Leak at ball of cable 3-4</li> </ul>	<ul style="list-style-type: none"> <li>- Replace control unit</li> <li>- Replace transmission</li> <li>- Replace control unit</li> </ul>
<p>4.4 No gearshift (whether cold or warm)</p> <ul style="list-style-type: none"> <li>- Gearshift 1-2/2-1</li> <li>- Gearshift 1-2</li> <li>- Gearshift 2-3/3-2</li> <li>- Gearshift 2-3</li> <li>- Gearshift 3-4/4-3</li> <li>- Gearshift 3-4</li> </ul>	<ul style="list-style-type: none"> <li>- Governor dirty</li> <li>- Selector valve 1-2 jammed</li> <li>- Brake C or C' faulty</li> <li>- Governor jammed</li> <li>- Selector valve 2-3 jammed</li> <li>- Clutch E faulty</li> <li>- Leak at oil feed of clutch E (same as „moves off in 3rd”) Rectangular rings on engine shaft or turbine shaft faulty Check for leaks at protection cap in intermediate plate</li> <li>- Governor dirty</li> <li>- Selector valve 3-4 jammed</li> <li>- Brake C' faulty In this case gearshift 1-2 ok</li> <li>- Brake band C' not pretensioned (nut slackened)</li> <li>- Upshift valve 2-3-4 jammed</li> <li>- Pos. 3 valve jammed</li> </ul>	<ul style="list-style-type: none"> <li>- Replace governor cpl.</li> <li>- Replace control unit</li> <li>- Replace transmission</li> <li>- Replace governor</li> <li>- Replace control unit</li> <li>- Replace transmission</li> <li>- Replace transmission</li> <li>- Replace governor</li> <li>- Replace control unit</li> <li>- Replace transmission</li> <li>- Replace transmission</li> <li>- Replace control unit</li> <li>- Replace control unit</li> </ul>



## Troubleshooting the 4 HP 14/18 automatic transmission

Fault	Possible cause	Remedy
<p>4.5 Vehicle moves off in 2nd</p> <p>Vehicle moves off in 3rd</p> <p>Vehicle shifts 1-3</p> <p>Vehicle shifts 1-4</p>	<ul style="list-style-type: none"> <li>- Governor bush jammed</li> <li>- Selector valve 1-2 jammed</li> <li>- Brake band over-tightened</li> <li>- Brake band does not release</li>   <li>- Middle rectangular ring on governor flange faulty</li> <li>- Governor bush jammed</li> <li>- Selector valve 1-2 and 2-3 jammed</li> <li>- Leak at protective cap in intermediate flange (clutch B constantly filled)</li>   <li>- Selector valve 2-3 jammed</li> <li>- 2-3-4 valve jammed</li> <li>- 1-2-3 valve jammed (at face end of 1-2 valve)</li>   <li>- Engine cuts out</li> </ul>	<ul style="list-style-type: none"> <li>- Replace governor cpl.</li> <li>- Replace control unit</li> <li>- Correct setting</li> <li>- Replace transmission</li>   <li>- Replace transmission</li> <li>- Replace governor cpl.</li> <li>- Replace control unit</li> <li>- Replace transmission</li>   <li>- Replace control unit</li> <li>- Replace control unit</li> <li>- Replace control unit</li>   <li>- Replace control unit</li> </ul>
<p>4.6 Shift speeds</p> <ul style="list-style-type: none"> <li>- Zero load shift not ok</li> <li>- Full load shift points not ok</li> <li>- No kick-down shift 1-2/2-1</li> <li>2-3/3-2</li> <li>3-4/4-3</li> </ul>	<ul style="list-style-type: none"> <li>- Governor dirty</li> <li>- Leak in area of governor</li> <li>- Selector valves do not move freely</li>   <li>- Accelerator cable not correctly adjusted</li>   <li>- Accelerator cable not correctly adjusted</li> <li>- Accelerator cable not correctly adjusted</li> <li>- Accelerator cable not correctly adjusted</li> <li>- Imbalance in governor</li> </ul>	<ul style="list-style-type: none"> <li>- Replace governor cpl.</li> <li>- Replace transmission</li> <li>- Replace control unit</li>   <li>- Correct setting</li>   <li>- Correct setting</li> <li>- Correct setting</li> <li>- Correct setting</li> <li>- Correct setting</li> <li>- Replace governor</li> </ul>

## Troubleshooting the 4 HP 14/18 automatic transmission

Fault	Possible cause	Remedy
<p>4.7 Gearshift transitions</p> <ul style="list-style-type: none"> <li>- Zero load shifts too hard</li> <li>- Full load and KD shift takes too long</li> <li>- Full load and KD</li> <li>- Engine overrevs when shifting 3-4, Cable</li> <li>- Engine overrevs when shifting 4-3</li> </ul>	<ul style="list-style-type: none"> <li>- Damper not operating properly</li> <li>- Modulation pressure too high</li> <li>- Discs damaged</li> <li>- Damper not operating properly</li> <li>- Modulation pressure too low</li> <li>- Discs damaged</li> <li>- Modulation pressure not ok</li> <li>- Damper not operating properly</li> <li>- Accelerator cable not correctly adjusted (also applies to 4 HP 14)</li> <li>- Diaphragm control valve jams in overrun position</li> <li>- Cable of valve 3-4 does not operate freely</li> <li>- Brake band incorrectly adjusted</li> <li>- Modulation pressure not ok (also applies to 4 HP 14)</li> <li>- Operation of time control valve and shiftdown valve 4-3 not ok</li> <li>- Clutch A damaged</li> <li>- Operation of damper clutch A and cable of valve 4-3 not ok</li> <li>- With turbo version: Charge air pressure supply not ok</li> </ul>	<ul style="list-style-type: none"> <li>- Replace control unit</li> <li>- Replace control unit</li> <li>- Replace transmission</li> <li>- Replace control unit</li> <li>- Replace control unit</li> <li>- Replace transmission</li> <li>- Replace control unit</li> <li>- Replace control unit</li> <li>- Adjust cable</li> <li>- Replace control unit</li> <li>- Replace control unit</li> <li>- Replace transmission</li> <li>- Replace control unit</li> <li>- Replace control unit</li> <li>- Replace control unit</li> <li>- Replace transmission</li> <li>- Replace control unit</li> <li>- Replace control unit</li> <li>- Replace control unit</li> <li>- Examine supply lines</li> </ul>
<p>5. Position 2</p> <p>5.1 Manual downshift not ok</p>	<ul style="list-style-type: none"> <li>- Locking valve 2 does not operate freely</li> <li>- Governor does not operate freely</li> </ul>	<ul style="list-style-type: none"> <li>- Replace control unit</li> <li>- Replace governor cpl.</li> </ul>
<p>5.2 No engine braking action</p>	<ul style="list-style-type: none"> <li>- Brake C' damaged</li> </ul>	<ul style="list-style-type: none"> <li>- Replace transmission</li> </ul>



## Troubleshooting the 4 HP 14/18 automatic transmission

Fault	Possible cause	Remedy
<p><b>6. Position 1</b></p> <p>6.1 Manual down-shift 2-1 not ok</p>	<ul style="list-style-type: none"> <li>- Locking valve of 1st and Reverse does not operate freely</li> <li>- Governor does not operate freely</li> </ul>	<ul style="list-style-type: none"> <li>- Replace control unit</li> <li>- Replace governor cpl.</li> </ul>
<p>6.2 No engine braking action</p>	<ul style="list-style-type: none"> <li>- Brake D damaged</li> </ul>	<ul style="list-style-type: none"> <li>- Replace transmission</li> </ul>
<p><b>7. General faults</b></p> <p>7.1 Accelerator cable jams</p>	<ul style="list-style-type: none"> <li>- Nipple in accelerator cam slipped out</li> <li>- Excessive friction in sleeve of accelerator cable</li> <li>- Governor pressure plunger jammed</li> </ul>	<ul style="list-style-type: none"> <li>- Insert nipple or replace accelerator cable</li> <li>- Replace accelerator cable</li> <li>- Replace control unit</li> </ul>
<p>7.2 After long journey, noises and interruption to positive engagement</p>	<ul style="list-style-type: none"> <li>- Oil strainer at control unit dirty</li> </ul>	<ul style="list-style-type: none"> <li>- Replace oil strainer</li> </ul>
<p>7.3 No positive engagement forward or backward, loud noises</p>	<ul style="list-style-type: none"> <li>- Driver plate between converter and engine broken off</li> <li>- Pump driver broken off</li> </ul>	<ul style="list-style-type: none"> <li>- Replace transmission</li> <li>- Replace transmission</li> </ul>

## Troubleshooting the 4 HP 14/18 automatic transmission

Fault	Possible cause	Remedy
<p><b>8. Leaks</b></p> <p>8.1 Oil drips out of converter bell housing</p>	<ul style="list-style-type: none"> <li>- Gasket in converter bell housing damaged</li> <li>- Leak at weld seam of converter</li> </ul>	<ul style="list-style-type: none"> <li>- Replace gasket</li> <li>- Replace converter</li> </ul>
<p>8.2 Leak between transmission housing and converter bell housing</p>	<ul style="list-style-type: none"> <li>- Fastening bolts on converter bell housing have loosened</li> </ul>	<ul style="list-style-type: none"> <li>- Tighten bolts</li> </ul>
<p>8.3 Leak between transmission housing and oil pan</p>	<ul style="list-style-type: none"> <li>- Fastening bolts on oil pan loosened (oil pan twisted)</li> <li>- Oil pan gasket damaged</li> </ul>	<ul style="list-style-type: none"> <li>- Tighten bolts or replace oil pan</li> <li>- Replace gasket</li> </ul>
<p>8.4 Leak between transmission housing and side cover</p>	<ul style="list-style-type: none"> <li>- Fastening bolts slackened</li> </ul>	<ul style="list-style-type: none"> <li>- Tighten bolts</li> </ul>
<p>8.5 Leak at oil cooler</p>	<ul style="list-style-type: none"> <li>- Screw connection loose</li> <li>- Gasket damaged</li> <li>- Leak at cooler</li> </ul>	<ul style="list-style-type: none"> <li>- Tighten bolt</li> <li>- Replace gasket</li> <li>- Replace cooler</li> </ul>
<p>8.6 Leak at cover of brake C'</p>	<ul style="list-style-type: none"> <li>- Outer O-Ring damaged (cover C')</li> </ul>	<ul style="list-style-type: none"> <li>- Replace O-ring</li> </ul>



## Troubleshooting the 4 HP 14/18 automatic transmission

Fault	Possible cause	Remedy
8.7 Leak adjusting bolt of brake band C'	<ul style="list-style-type: none"> <li>- O-ring at pin damaged</li> </ul>	<ul style="list-style-type: none"> <li>- Replace O-ring (control unit has to be removed)</li> </ul>
8.8 Leak at retaining bolts for bearing ring of side shaft	<ul style="list-style-type: none"> <li>- Bolts slackened</li> <li>- Seals damaged</li> <li>- Does not apply to 4 HP 18</li> </ul>	<ul style="list-style-type: none"> <li>- Tighten bolts</li> <li>- Replace seals</li> </ul>
8.9 Loss of oil at accelerator cable connector	<ul style="list-style-type: none"> <li>- O-ring on connector damaged</li> </ul>	<ul style="list-style-type: none"> <li>- Replace O-ring; also accelerator cable, if necessary</li> </ul>
8.10 Leak at differential	<ul style="list-style-type: none"> <li>- Shaft seals at the input shafts damaged</li> </ul>	<ul style="list-style-type: none"> <li>- Replace shaft seals</li> </ul>
8.11 Leak at differential extension	<ul style="list-style-type: none"> <li>- O-ring damaged</li> <li>- Bolts slackened</li> </ul>	<ul style="list-style-type: none"> <li>- Replace O-ring</li> <li>- Tighten bolts</li> </ul>
8.12 Leak at speedometer	<ul style="list-style-type: none"> <li>- O-ring in speedometer sleeve damaged</li> <li>- Shaft seal in speedometer sleeve damaged</li> </ul>	<ul style="list-style-type: none"> <li>- Replace O-ring</li> <li>- Renew speedometer sleeve cpl.</li> </ul>

## Troubleshooting the 4 HP 14/18 automatic transmission

Fault	Possible cause	Remedy
8.13 Leak at breather	<ul style="list-style-type: none"> <li>- Oil level too high (severe foaming)</li> <li>- Wrong grade of oil</li> </ul>	<ul style="list-style-type: none"> <li>- Correct oil level</li> <li>- Replace transmission</li> </ul>
8.14 Leak at selector shaft	<ul style="list-style-type: none"> <li>- Shaft seal damaged</li> </ul>	<ul style="list-style-type: none"> <li>- Replace shaft seal</li> </ul>
<p><b>9. Noises</b></p> <p>9.1 Noises in all positions</p> <p>Intake noises from oil pump</p>	<ul style="list-style-type: none"> <li>- Oil level too low</li> <li>- Leak at control unit</li> <li>- Oil strainer blocked</li> </ul>	<ul style="list-style-type: none"> <li>- Correct oil level</li> <li>- Replace control unit</li> <li>- Replace oil strainer</li> </ul>
9.2 Noises varying according to speed	<ul style="list-style-type: none"> <li>- Bearing setting of spur gear drive has altered or incorrectly adjusted</li> <li>- Bearing setting of differential has altered or incorrectly adjusted</li> </ul>	<ul style="list-style-type: none"> <li>- Replace transmission</li> <li>- Replace transmission</li> </ul>



## 1.7. Checking the transmission

The follow points must be checked:

### Oil level correct

Always check the oil (ATF) level with the engine idling, in selector lever position P. The correct oil level can only be determined when the transmission is warm (80°C), and must then be between the MAX and MIN marks on the dipstick.

### Oil level too low

The engine will overspeed when the vehicle is cornered, there will be valve chatter as a result of air inclusions and general malfunctioning of the transmission.

### Oil level too high

Risk of severe splash losses and foaming, severe rise in temperature if driven fast. Oil lost through breather.

### Correct engine settings

Correct idle speed (comply with vehicle manufacturer's instructions).

### Drive is taken up forwards and in reverse

Selector linkage is correctly adjusted (comply with vehicle manufacturer's instructions).

### Stall points

See Group 21 - Technical Data, Tables, Pressures" in bulletin file No. 401.

### Shift points

See Group 21 - Technical Data, Tables, Pressures" in bulletin file No. 401.

### Shift quality

Correct throttle cable adjustment: see Item 1.6, „Requirements for correct functioning". For correct throttle cable adjustment, refer to vehicle manufacturer's instructions.

### Noises

See troubleshooting table, Items 7 and 9.

**AVTGR**  
ВСЕ ДЛЯ АКПП





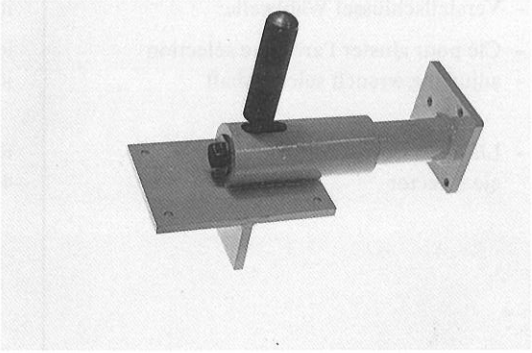
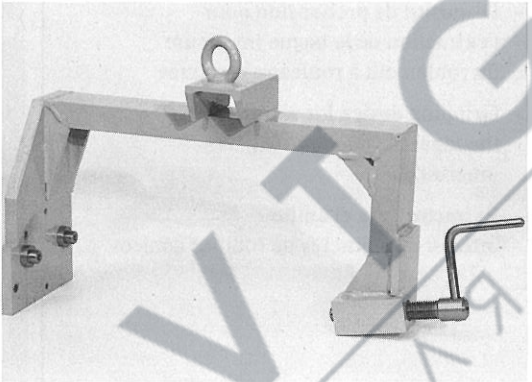
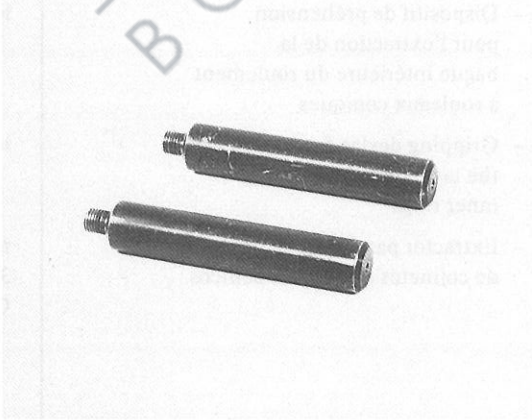

**1.8 Spezialwerkzeuge 4 HP 18**  
**Outils spéciaux 4 HP 18**  
**Special Tools 4 HP 18**  
**Utililaje Especial 4 HP 18**

Bild Nr. Photo No. Picture Fig. No.	GEGENSTAND OUTIL TOOL UTIL	Bestell-Nr. / Verwendungszweck No de commande / Application Part No / Application Ref. ZF / Aplicacion	Bemerkungen Observations Remarks Observaciones
1	<p>84254</p> 	<p>5 X 46 000 244</p> <ul style="list-style-type: none"> <li>- Aufnahmebügel für das komplette Getriebe mit Werkbankhalterung</li> <li>- Support pour la boîte complète avec support d'établi</li> <li>- Transmission work bench holding fixture</li> <li>- Soporte para la caja de cambios completa, incl. soporte para banco de trabajo.</li> </ul>	<p>identisch</p> <p>identique</p> <p>identical to</p> <p>idéntico para 4 HP 14</p>
2	<p>85411</p> 	<p>5 X 46 000 329</p> <ul style="list-style-type: none"> <li>- Spannbügel</li> <li>- Bride de fixation</li> <li>- Clamp</li> <li>- Util de sujeción</li> </ul>	<p>Mit Aufnahmebügel 5 X 46 000 244 verschraubt</p> <p>Visser avec le support 5 X 46 000 244</p> <p>Screw to the holding fixture 5 X 46 000 244</p> <p>Atornillado al soporte 5 X 46 000 244</p>
3	<p>81021</p> 	<p>5 X 46 000 110</p> <ul style="list-style-type: none"> <li>- Wandlerausziehgriffe (2 Stück)</li> <li>- Poignées de dépose/repose du convertisseur</li> <li>- Mounting grips (2) for Removal and to Install Converter</li> <li>- Mangos (2 unidades) para sacar el convertidor</li> </ul>	<p>identisch</p> <p>identique</p> <p>identical to</p> <p>idéntico para 3 HP 22 CX</p>

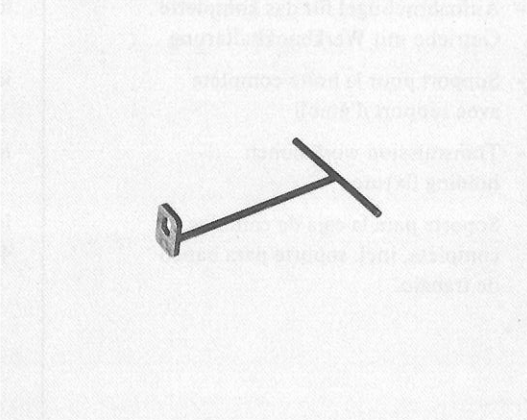
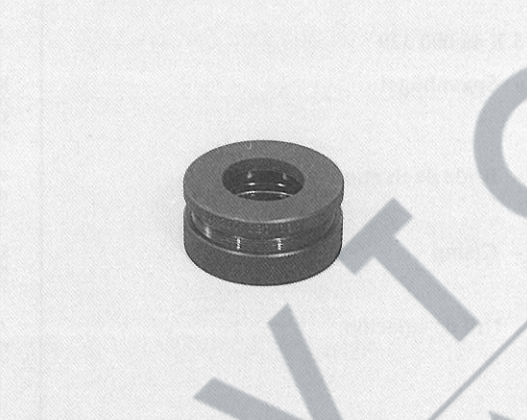
**Spezialwerkzeuge 4 HP 18**  
**Outils spéciaux 4 HP 18**  
**Special Tools 4 HP 18**  
**Utilillaje Especial 4 HP 18**

Bild Nr. Photo No. Picture Fig. No.	GEGENSTAND OUTIL TOOL UTIL	Bestell-Nr. / Verwendungszweck No de commande / Application Part No / Application Ref. ZF / Aplicacion	Bemerkungen Observations Remarks Observaciones
4	<p>84278</p> 	<p>5 P 95 000 285</p> <ul style="list-style-type: none"> <li>- Verstell Schlüssel Wählwelle</li> <li>- Clé pour ajuster l'arbre de sélection</li> <li>- adjusting wrench selector shaft</li>   <li>- Llave de ajuste para eje selector</li> </ul>	<p>identisch identique identical to</p> <p>idéntico para 4 HP 14</p>
5	<p>81026</p> 	<p>Rollex 48 500</p> <ul style="list-style-type: none"> <li>- Greifstück zum Abziehen des Kegelrollenlager-Innenrings</li> <li>- Dispositif de préhension pour l'extraction de la bague intérieure du roulement à rouleaux coniques</li> <li>- Gripping device for withdrawal of the tapered roller bearing inner rings</li> <li>- Extractor para el anillo interior de cojinetes de rodillos cónicos</li> </ul>	<p>identisch identique identical to</p> <p>idéntico para 4 HP 14</p>
6	<p>81028</p> 	<p>Rollex 503 349/S</p> <ul style="list-style-type: none"> <li>- Greifstück zum Abziehen der Kegelrollenlager-Innenringe</li> <li>- Dispositif de préhension pour l'extraction de la bague intérieure du roulement à rouleaux coniques</li> <li>- Gripping device for withdrawal of the tapered roller bearing inner rings</li> <li>- Extractor para anillos interiores de cojinetes de rodillos cónicos</li> </ul>	<p>identisch identique identical to</p> <p>idéntico para 3 HP 22 CX</p>



**Spezialwerkzeuge 4 HP 18**  
**Outils spéciaux 4 HP 18**  
**Special Tools 4 HP 18**  
**Utillaje Especial 4 HP 18**

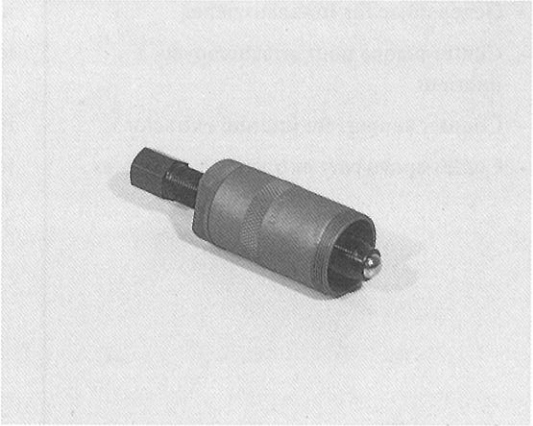
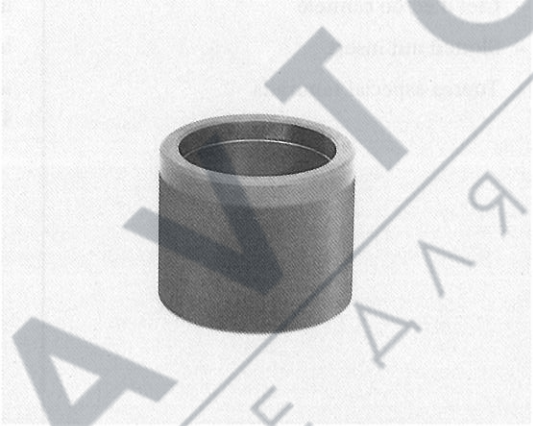

Bild Nr. Photo No. Picture Fig. No.	GEGENSTAND OUTIL TOOL UTIL	Bestell-Nr. / Verwendungszweck No de commande / Application Part No / Application Ref. ZF / Aplicacion	Bemerkungen Observations Remarks Observaciones
7	<p>81027</p> 	<p>Rollex 1 000 1</p> <ul style="list-style-type: none"> <li>- Grundgerät zu Greifstück</li> <li>- Outil de base pour dispositif de préhension</li> <li>- Basic tool for gripping device</li> <li>- Util básico para extractor</li> </ul>	<p>identisch identique identical to idéntico para 3 HP 22 CX 4 HP 14</p>
8	<p>85412</p> 	<p>5 X 46 000 328</p> <ul style="list-style-type: none"> <li>- Auspreßstück für Kegelrollenlager-Innenring</li> <li>- Dispositif d'exprimer pour l'extraction de la bague intérieure du roulement à rouleaux coniques</li> <li>- Squeezing piece for the tapered roller bearing inner ring</li> <li>- Extractor para anillo interior cojinete de rodillos cónicos</li> </ul>	

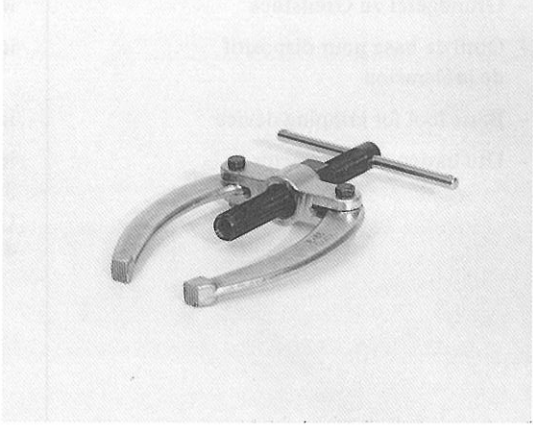
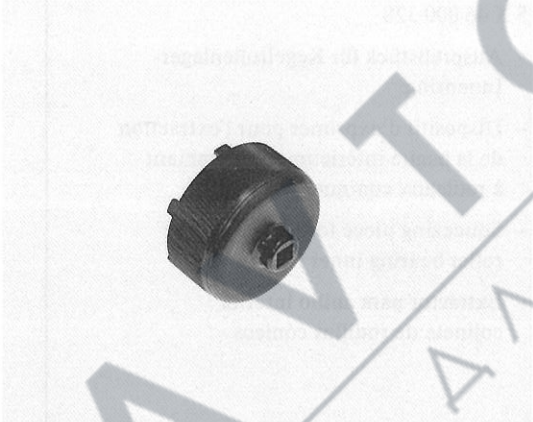
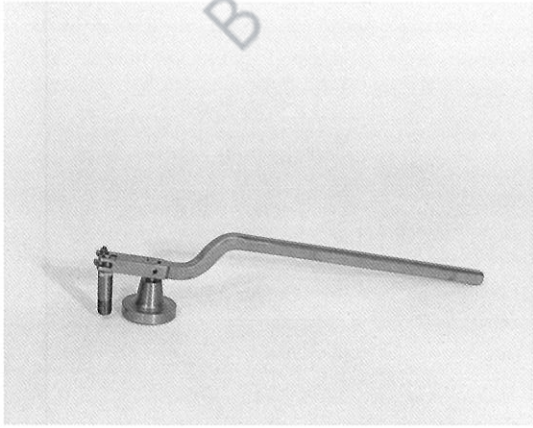
**Spezialwerkzeuge 4 HP 18**  
**Outils spéciaux 4 HP 18**  
**Special Tools 4 HP 18**  
**Utillaje Especial 4 HP 18**



Bild Nr. Photo No. Picture Fig. No.	GEGENSTAND OUTIL TOOL UTIL	Bestell-Nr. / Verwendungszweck No de commande / Application Part No / Application Ref. ZF / Aplicacion	Bemerkungen Observations Remarks Observaciones
9	<p>85414</p> 	<p>Kukko Gr. 22/2</p> <ul style="list-style-type: none"> <li>- Gegenstütze für Innenauszieher</li> <li>- Contre-plaque pour arrachemoyeu interieur</li> <li>- Counter support for internal extractor</li> <li>- Contra-apoyo para extractor de interiores</li> </ul>	<p>identisch identique identical to idéntico para 4 HP 14 3 HP 22 CX</p>
10	<p>84256</p> 	<p>5 X 46 000 155</p> <ul style="list-style-type: none"> <li>- Nutmutterschlüssel</li> <li>- Clef d'écrou cannelé</li> <li>- Slotted nut insert</li> <li>- Tuerca especial ranurada</li> </ul>	<p>identisch identique identical to idéntico para 4 HP 14</p>
11	<p>85415</p> 	<p>5 X 46 000 273</p> <ul style="list-style-type: none"> <li>- Montagevorrichtung für Bremse C'</li> <li>- Montage pour frein C'</li> <li>- Mounting device for brake C'</li> <li>- Util de montaje del freno C'</li> </ul>	

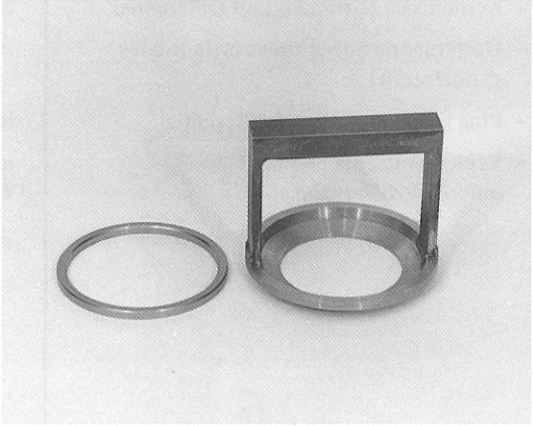

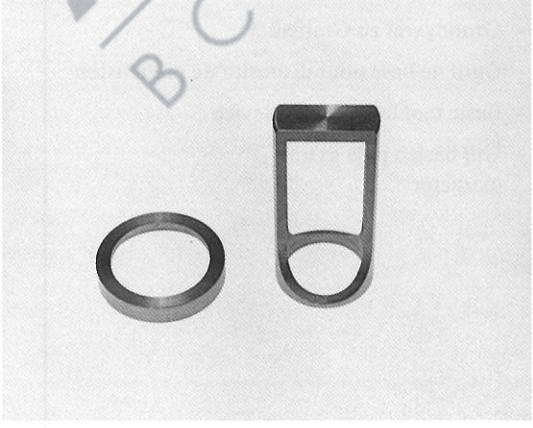
**Spezialwerkzeuge 4 HP 18**  
**Outils spéciaux 4 HP 18**  
**Special Tools 4 HP 18**  
**Utilillaje Especial 4 HP 18**

Bild Nr. Photo No. Picture Fig. No.	GEGENSTAND OUTIL TOOL UTIL	Bestell-Nr. / Verwendungszweck No de commande / Application Part No / Application Ref. ZF / Aplicacion	Bemerkungen Observations Remarks Observaciones
12	<p>85 417</p> 	<p>5 X 46 000 221</p> <ul style="list-style-type: none"> <li>- Montagevorrichtung für Tellerfeder Kupplung B</li> <li>- Montage pour ressort à disques embrayage B</li> <li>- Mounting device for plate spring clutch B</li> <li>- Util de montage para diafragma (arandela belleville) embrague B</li> </ul>	
13	<p>84 258</p> 	<p>5 X 46 000 167 (teilweise)</p> <ul style="list-style-type: none"> <li>- Montagehilfe</li> <li>- Aide pour montage</li> <li>- Mounting assistance</li> <li>- Ayuda para del montaje</li> </ul>	<p>identisch  identique  identical to  idéntico a  4 HP 22  4 HP 14</p>
14	<p>84 260</p> 	<p>5 X 46 000 148</p> <ul style="list-style-type: none"> <li>- Montagevorrichtung für Tellerfeder Kupplung E</li> <li>- Montage pour ressort à disques embrayage E</li> <li>- Mounting device for plate spring clutch E</li> <li>- Util de montage para diafragma (arandela belleville) embrague E</li> </ul>	<p>identisch  identique  identical to  idéntico a  4 HP 14</p>

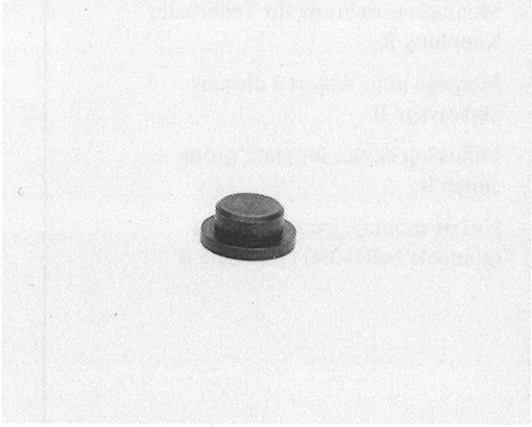
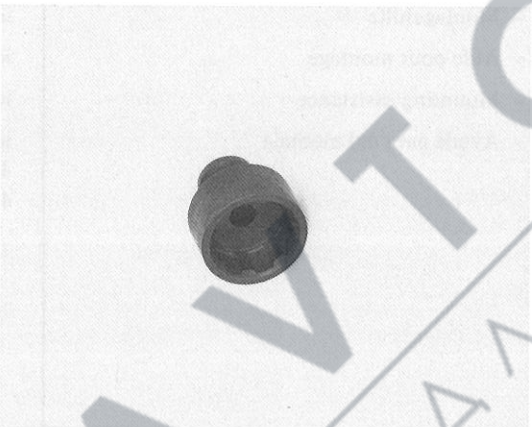
Spezialwerkzeuge 4 HP 18  
 Outils spéciaux 4 HP 18  
 Special Tools 4 HP 18  
 Utillaje Especial 4 HP 18

Bild Nr. Photo No. Picture Fig. No.	GEGENSTAND OUTIL TOOL UTIL	Bestell-Nr. / Verwendungszweck No de commande / Application Part No / Application Ref. ZF / Application	Bemerkungen Observations Remarks Observaciones
15	85418 	5 X 46 000 297 - Kerneinsatz Stirnräder und Differential - Garniture de noyau roues cylindriques et différentiel - Plug for spur gears and differential - Suplemento para pareja de piñones y diferencial	identisch identique identical to idéntico a 4 HP 14
16	89068 	5 X 46 000 615 - Spezialschlüssel für Entlüfter - Special wrench for vent - Douille speciale pour reniflard - Llave especial para respiradero	
17	90148 	Rollex Gr. I A - Grundgerät zu Greifstück - Outil de base pour dispositif de préhension - Basic tool for gripping device - Útil basico para extractor	

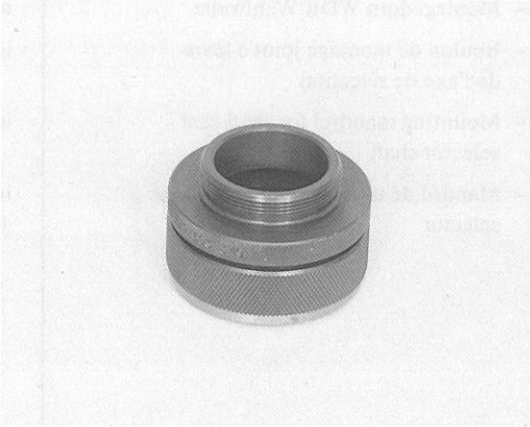
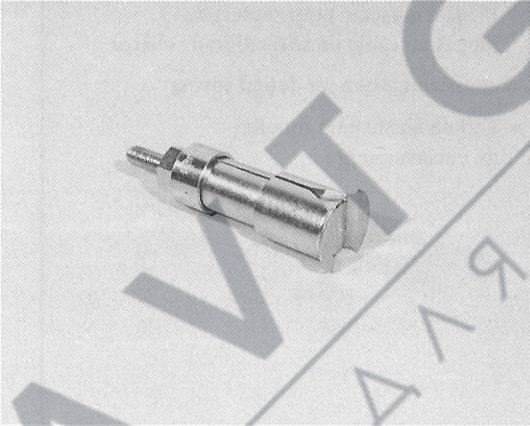
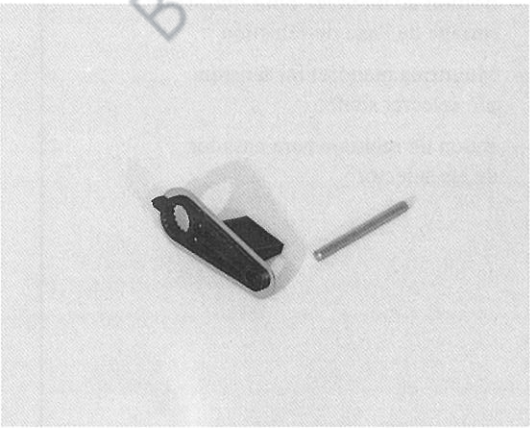

**Spezialwerkzeuge 4 HP 18**  
**Outils spéciaux 4 HP 18**  
**Special Tools 4 HP 18**  
**Utillaje Especial 4 HP 18**

Bild Nr. Photo No. Picture Fig. No.	GEGENSTAND OUTIL TOOL UTIL	Bestell-Nr. / Verwendungszweck No de commande / Application Part No / Application Ref. ZF / Aplicacion	Bemerkungen Observations Remarks Observaciones
18	<p>90 149</p> 	<p>Rollex 503 349 I</p> <ul style="list-style-type: none"> <li>- Greifstück zum Abziehen des Kegelrollenlager-Innenrings</li> <li>- Dispositif de préhension pour l'extraction de la bague intérieure du roulement à rouleaux coniques</li> <li>- Gripping device for withdrawal of the tapered roller bearing inner ring</li> <li>- Extractor para anillo interior de cojinete de rodillos cónicos</li> </ul>	
19	<p>81 025</p> 	<p>Kukko Gr. 21/7</p> <ul style="list-style-type: none"> <li>- Innenauszieher für Kegelrollenlager-Außenringe</li> <li>- Arrache-moyeu intérieur pour bague extérieure du roulement à rouleaux coniques</li> <li>- Internal extractor for outer rings of tapered roller bearings</li> <li>- Extractor de interiores para anillos exteriores de cojinetes de rodillos cónicos</li> </ul>	<p>identisch</p> <p>identique</p> <p>identical to</p> <p>idéntico a 4 HP 14</p>
20	<p>90 150</p> 	<p>0501 311 626</p> <ul style="list-style-type: none"> <li>- Hebel zur Einstellung des Positionsschalters</li> <li>- Levier pour le positionnement du sélecteur de position</li> <li>- Lever for selector switch adjustment</li> <li>- Palanca para el reglaje del interrupttor de posición</li> </ul>	

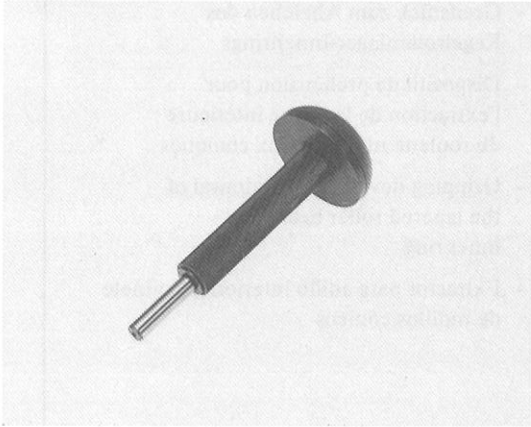
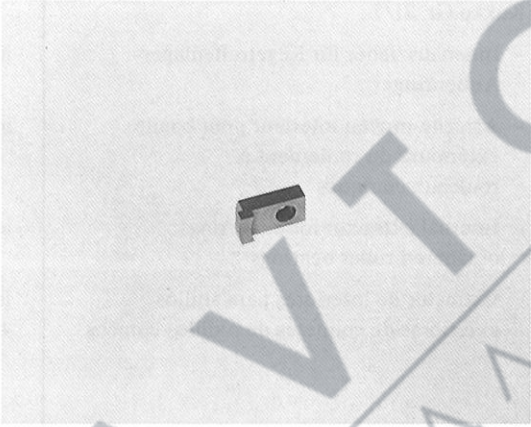
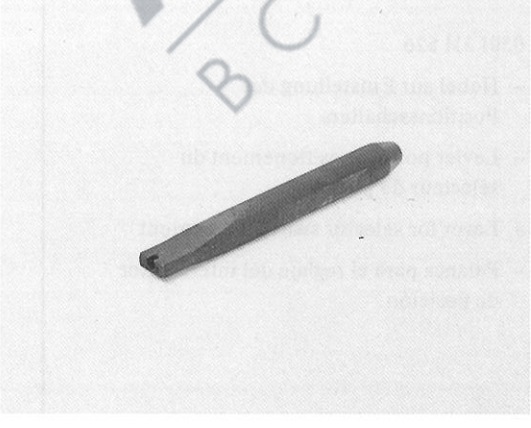

Spezialwerkzeuge 4 HP 18  
 Outils spéciaux 4 HP 18  
 Special Tools 4 HP 18  
 Utillaje Especial 4 HP 18

Bild Nr. Photo No. Picture Fig. No.	GEGENSTAND OUTIL TOOL UTIL	Bestell-Nr. / Verwendungszweck No de commande / Application Part No / Application Ref. ZF / Aplicacion	Bemerkungen Observations Remarks Observaciones
21	84266 	5 X 46 000 187 - Montagedorn WDR Wählwelle - Boulon de montage joint à lèvres de l'axe de sélection - Mounting mandrel for shaft seal selector shaft - Mandril de montaje de retén en eje selector	identisch identique identical to idéntico a 4 HP 14
22	84274 	5 P 89 002 209 - Einstellstück für Rastenfeder - Pièce d'ajustage pour ressort de rappel du câble de correction de charge - adjusting piece for detent spring - Util de ajuste para muelle de enclavamiento	
23	85423 	5 X 46 000 291 - Montagebolzen für Spannhülse Wählwelle - Boulon de montage pour douille de serrage de l'axe de sélection - Mounting mandrel for tension pin selector shaft - Bulón de montaje para pasador de eje selector	

**Spezialwerkzeuge 4 HP 18**  
**Outils spéciaux 4 HP 18**  
**Special Tools 4 HP 18**  
**Utillaje Especial 4 HP 18**

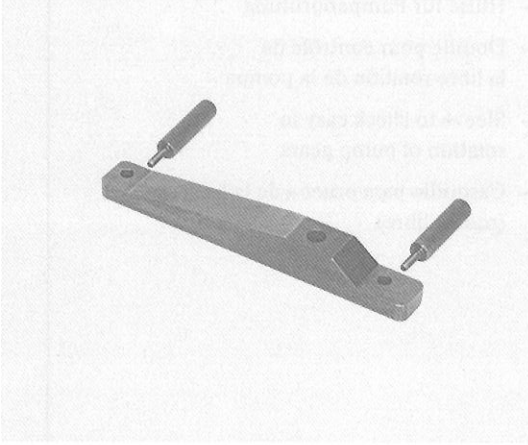
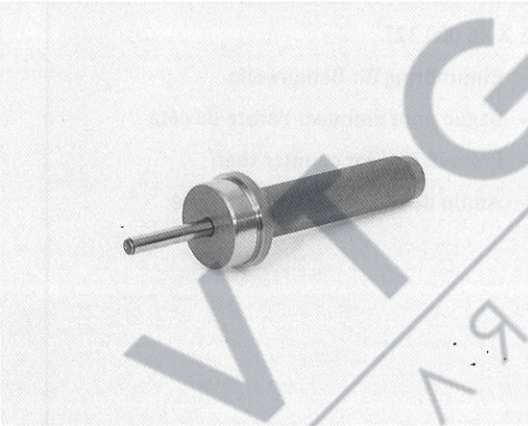
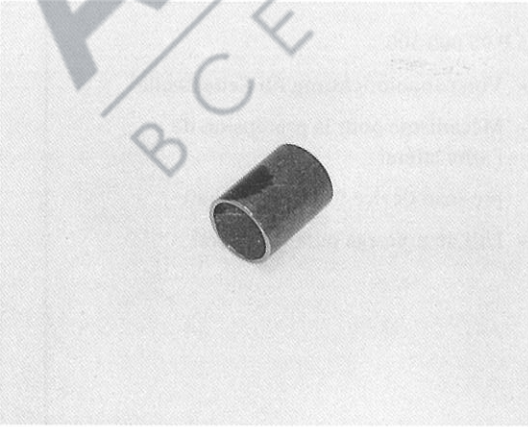
Bild Nr. Photo No. Picture Fig. No.	GEGENSTAND OUTIL TOOL UTIL	Bestell-Nr. / Verwendungszweck No de commande / Application Part No / Application Ref. ZF / Aplicacion	Bemerkungen Observations Remarks Observaciones
24	<p>90155</p> 	<p>5 P 95 000 301</p> <ul style="list-style-type: none"> <li>- Gegenhalter für Rastenscheibe</li> <li>- Contre-appui pour disque à crans</li> <li>- Counter-clamp for stop plate</li> <li>- Contra-apoyo para disco de enclavamiento</li> </ul>	
25	<p>85416</p> 	<p>5 X 46 000 267</p> <ul style="list-style-type: none"> <li>- Einschlagdorn für Hülse C'</li> <li>- Manchon pliant pour douille C'</li> <li>- Wrapping mandrel for sleeve C'</li> <li>- Mandril para casquillo C'</li> </ul>	
26	<p>84271</p> 	<p>5 X 46 000 300</p> <ul style="list-style-type: none"> <li>- Montagehülse für Kegelrollenlager-Innenring</li> <li>- Douille de montage pour bague intérieure du roulement à rouleaux coniques</li> <li>- Mounting sleeve for inner ring of tapered roller bearings</li> <li>- Casquillo de montaje para anillo interior de cojinete de rodillos cónicos</li> </ul>	<p>identisch</p> <p>identique</p> <p>identical to 4 HP 14</p>

**Spezialwerkzeuge 4 HP 18**  
**Outils spéciaux 4 HP 18**  
**Special Tools 4 HP 18**  
**Utillaje Especial 4 HP 18**

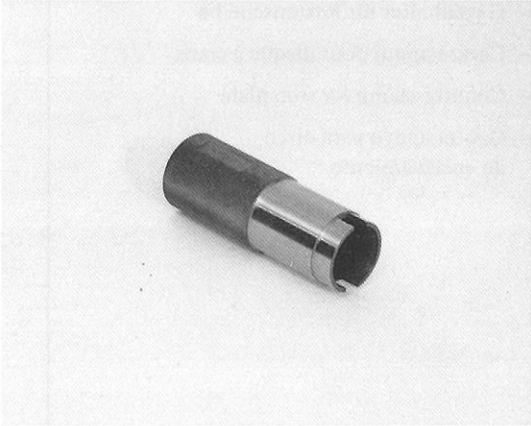
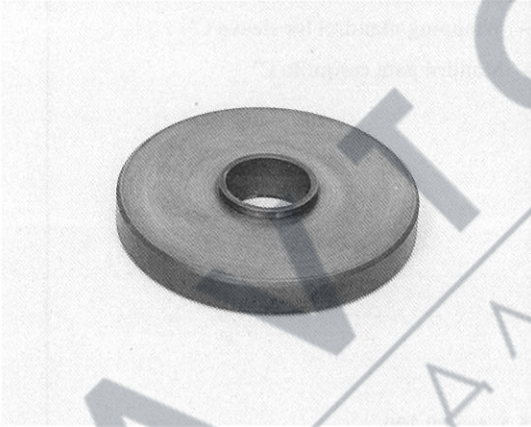
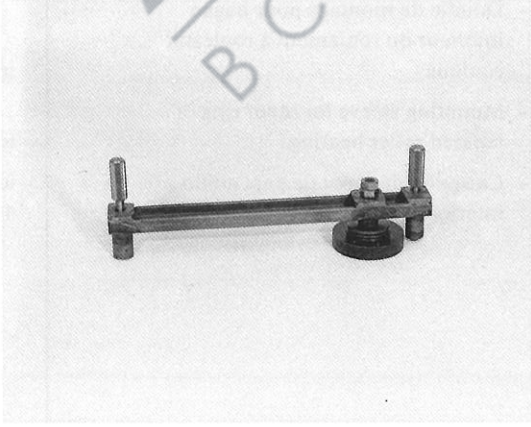
Bild Nr. Photo No. Picture Fig. No.	GEGENSTAND OUTIL TOOL UTIL	Bestell-Nr. / Verwendungszweck No de commande / Application Part No / Application Ref. ZF / Application	Bemerkungen Observations Remarks Observaciones
27	<p>85425</p> 	<p>5 X 46 000 306</p> <ul style="list-style-type: none"> <li>- Hülse für Pumpenprüfung</li> <li>- Douille pour contrôle de la libre rotation de la pompe</li> <li>- Sleeve to check easy in rotation of pump gears</li> <li>- Casquillo para prueba de la bomba (rodaje libre)</li> </ul>	
28	<p>85426</p> 	<p>5 X 46 000 327</p> <ul style="list-style-type: none"> <li>- Einpreßring für Seitenwelle</li> <li>- Bague pour enfoncer l'arbre de côté</li> <li>- Press-in ring for counter shaft</li> <li>- Anillo de montaje para eje lateral</li> </ul>	
29	<p>85427</p> 	<p>5 P 95 000 300</p> <ul style="list-style-type: none"> <li>- Vorspanneinrichtung für Seitenwelle</li> <li>- Mécanisme pour la prétension de l'arbre latéral</li> <li>- pre-load device for counter shaft</li> <li>- Util de precarga para eje lateral</li> </ul>	

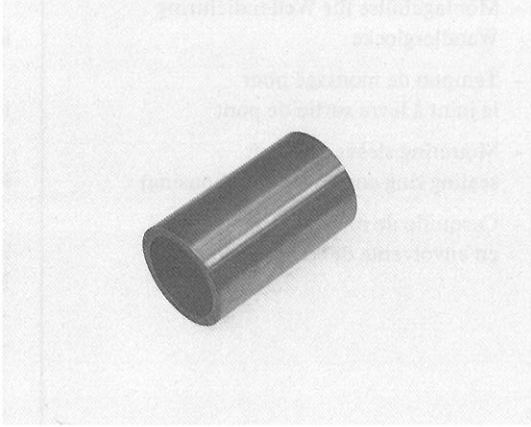
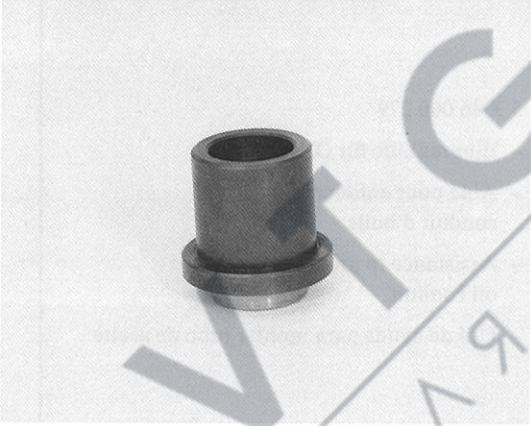
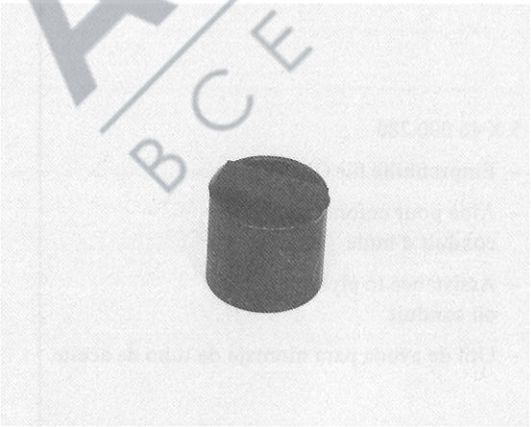

**Spezialwerkzeuge 4 HP 18**  
**Outils spéciaux 4 HP 18**  
**Special Tools 4 HP 18**  
**Utillaje Especial 4 HP 18**

Bild Nr. Photo No. Picture Fig. No.	GEGENSTAND OUTIL TOOL UTIL	Bestell-Nr. / Verwendungszweck No de commande / Application Part No / Application Ref. ZF / Aplicacion	Bemerkungen Observations Remarks Observaciones
30	<p>82 177</p> 	<p>5 X 46 000 174</p> <ul style="list-style-type: none"> <li>- Montagehülse für Turm 4. Gang</li> <li>- Douille de montage pour parts 4ième vitesse</li> <li>- Mounting Sleeve for 4.th gear assembly</li> <li>- Casquillo de montaje para piezas de la 4ª velocidad</li> </ul>	
31	<p>85 421</p> 	<p>5 X 46 000 369</p> <ul style="list-style-type: none"> <li>- Einpreßstempel für Wellendichtring</li> <li>- Poinçon pour enfoncer le joint à lèvres</li> <li>- Punch to press in the shaft sealing ring</li> <li>- Empujador para retén</li> </ul>	
32	<p>90 151</p> 	<p>5 X 46 000 742</p> <ul style="list-style-type: none"> <li>- Montagehülse für Kegelrollenlager-Innenring</li> <li>- Tube de montage pour la bague intérieure du roulement à rouleaux coniques</li> <li>- Mounting sleeve for ball-bearing inner ring</li> <li>- Casquillo de montaje para anillo interior de cojinete de rodillos cónicos</li> </ul>	<p>identisch</p> <p>identique</p> <p>identical to</p> <p>idéntico a PSA - 7.0327-G - 9017-T.G</p>

Spezialwerkzeuge 4 HP 18  
 Outils spéciaux 4 HP 18  
 Special Tools 4 HP 18  
 Utillaje Especial 4 HP 18

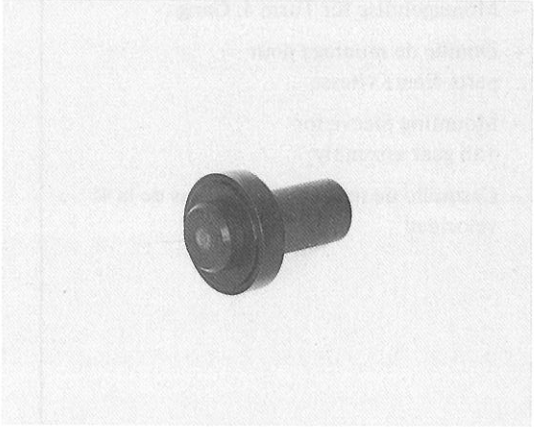
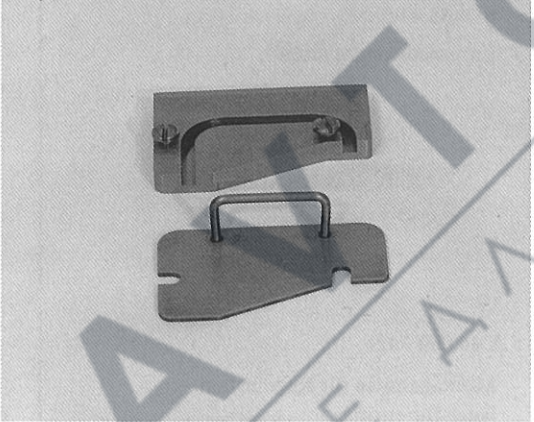
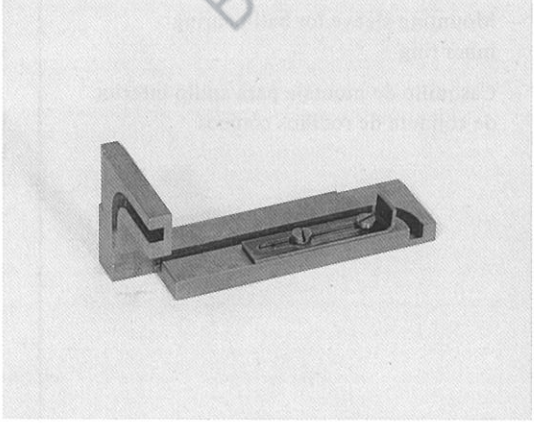
Bild Nr. Photo No. Picture Fig. No.	GEGENSTAND OUTIL TOOL UTIL	Bestell-Nr. / Verwendungszweck No de commande / Application Part No / Application Ref. ZF / Aplicacion	Bemerkungen Observations Remarks Observaciones
33	90152 	5 X 46 000 743 - Montagehülse für Wellendichtring Wandlerglocke - Tampon de montage pour le joint à lèvres sortie de pont - Mounting sleeve for shaft sealing ring converter bell (housing) - Casquillo de montaje para retén en envolvente del convertidor	identisch identique idéntical to idéntico para PSA - 7.0327-C - 9017-T.C
34	85433 	5 X 46 000 279 - Einpreßhilfe für Ölrohr - Aide pour enfoncer le conduit d'huile - Assistance to press in the oil conduit - Util de ayuda para montar tubo de aceite	
35	85434 	5 X 46 000 280 - Einpreßhilfe für Ölrohr - Aide pour enfoncer le conduit d'huile - Assistance to press in the oil conduit - Util de ayuda para montaje de tubo de aceite	

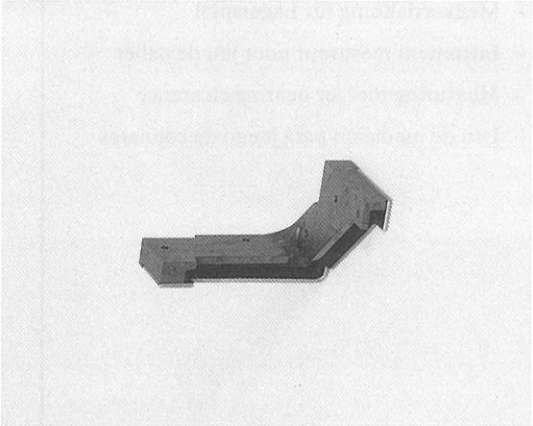
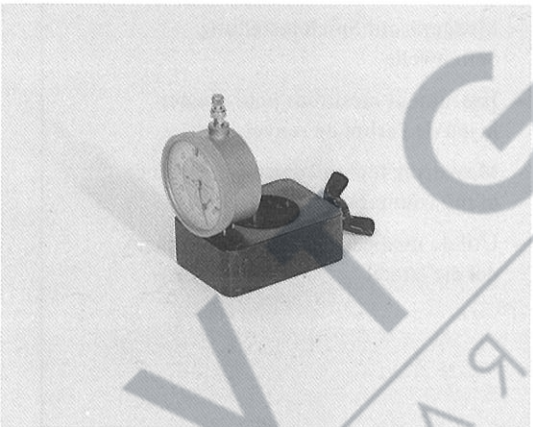
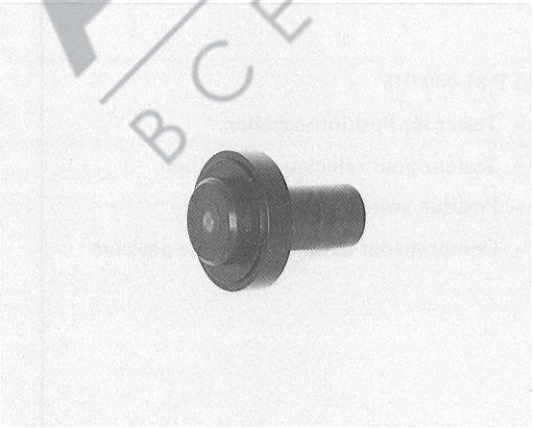

**Spezialwerkzeuge 4 HP 18**  
**Outils spéciaux 4 HP 18**  
**Special Tools 4 HP 18**  
**Utillaje Especial 4 HP 18**

Bild Nr. Photo No. Picture Fig. No.	GEGENSTAND OUTIL TOOL UTIL	Bestell-Nr. / Verwendungszweck No de commande / Application Part No / Application Ref. ZF / Aplicacion	Bemerkungen Observations Remarks Observaciones
36	<p>85 401</p> 	<p>5 X 46 000 352</p> <ul style="list-style-type: none"> <li>- Einpreßhilfe für Rohr</li> <li>- Aide pour enfoncer le tuyau de raccordement</li> <li>- Assistance to press in the connecting piece</li> <li>- Util de montage para tubo de aceite</li> </ul>	
37	<p>85 435</p> 	<p>5 P 01 001 522</p> <ul style="list-style-type: none"> <li>- Meßgerät für Getriebe-Axialspiel</li> <li>- Instrument mesureur pour jeu axial de la boîte de vitesses</li> <li>- Measuring tool for axial clearance of transmission</li> <li>- Instrumento de medición para juego axial de la caja de cambios</li> </ul>	
38	<p>90 153</p> 	<p>5 X 46 000 744</p> <ul style="list-style-type: none"> <li>- Montagehülse WDR Verlängerung</li> <li>- Tampon de montage pour le joint à sortie de pont</li> <li>- Mounting sleeve for shaft seal ring extension</li> <li>- Útil de montaje para retén en pieza de prolongación</li> </ul>	<p>identisch</p> <p>identique</p> <p>identical to</p> <p>idéntico a PSA - 7.0327-B - 9017-T.B</p>



Spezialwerkzeuge 4 HP 18  
 Outils spéciaux 4 HP 18  
 Special Tools 4 HP 18  
 Utillaje Especial 4 HP 18

Bild Nr. Photo No. Picture Fig. No.	GEGENSTAND OUTIL TOOL UTIL	Bestell-Nr. / Verwendungszweck No de commande / Application Part No / Application Ref. ZF / Aplicacion	Bemerkungen Observations Remarks Observaciones
39	<p>85437</p> 	<p>5 P 01 001 458</p> <ul style="list-style-type: none"> <li>- Meßvorrichtung für Lagerspiel</li> <li>- Instrument mesureur pour jeu de palier</li> <li>- Measuring tool for bearing clearance</li> <li>- Util de medición para juego de cojinetes</li> </ul>	
40	<p>85438</p> 	<p>5 P 01 001 523</p> <ul style="list-style-type: none"> <li>- Meßgerät zur Spieleinstellung Seitenwelle</li> <li>- Instrument mesureur pour ajuster le jeu de l'arbre de renvoi</li> <li>- Measuring tool to adjust the clearance of the counter shaft</li> <li>- Util de medición para ajustar el juego del eje lateral</li> </ul>	
41	<p>90154</p> 	<p>5 P 81 000 038</p> <ul style="list-style-type: none"> <li>- Tester für Positionsschalter</li> <li>- Testeur pour sélecteur de position</li> <li>- Position switch tester</li> <li>- Comprobador del interrupter de posición</li> </ul>	

**AVTGR**  
ВСЕ ДЛЯ АКПП



## 2. Dismantling

### 2.1 Dismantling the transmission according to assembly groups

Bolt on mounting 5 X 46 000 244 with fixture 5 X 46 000 329, attach the transmission and turn it through 180 degrees.

Remove converter hoops if present.

#### **Important:**

If necessary, detach the oil cooler before the transmission is attached to the mounting.

(For this work, see Page 11.)

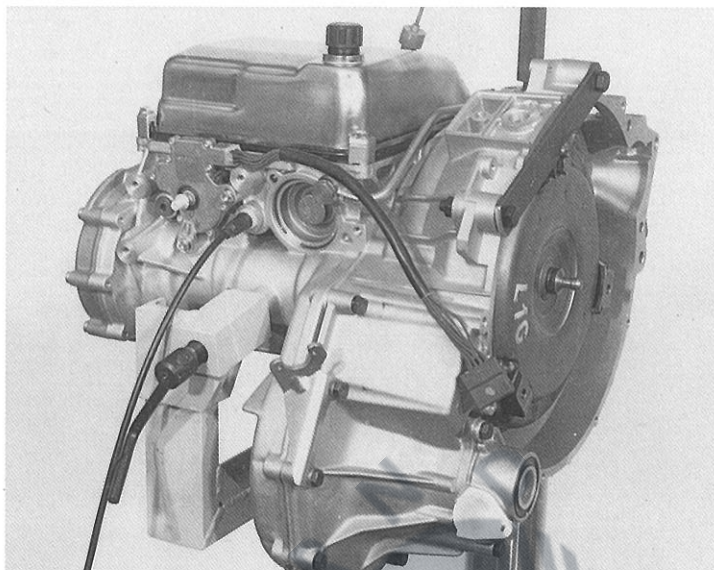

Take out the converter, using two 5 X 46 000 110 converter pullers.

#### **Warning:**

- oil will escape
- avoid damage to pump shaft sealing ring.

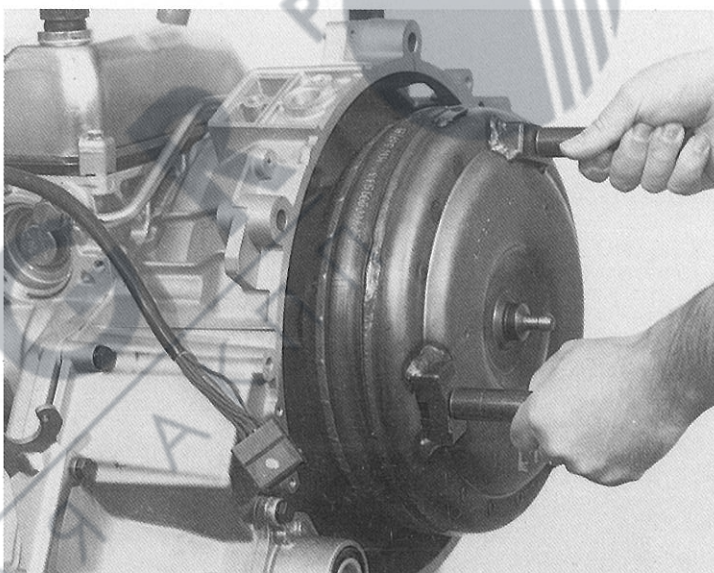

Reposition the transmission by 90 degrees, remove the 3 hex bolts and take off the cover containing the magnet.

(Wrench size = 10 mm.)

Take out the filter insert, turn the transmission through 90 degrees again and drain out the oil.

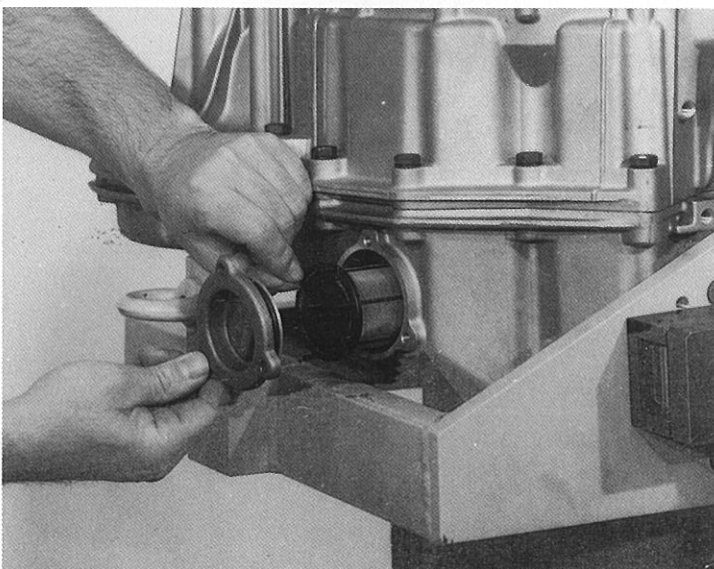



90004

Pull out the dipstick.  
Unscrew and remove the breather,  
using socket wrench 5 X 46 000 615.

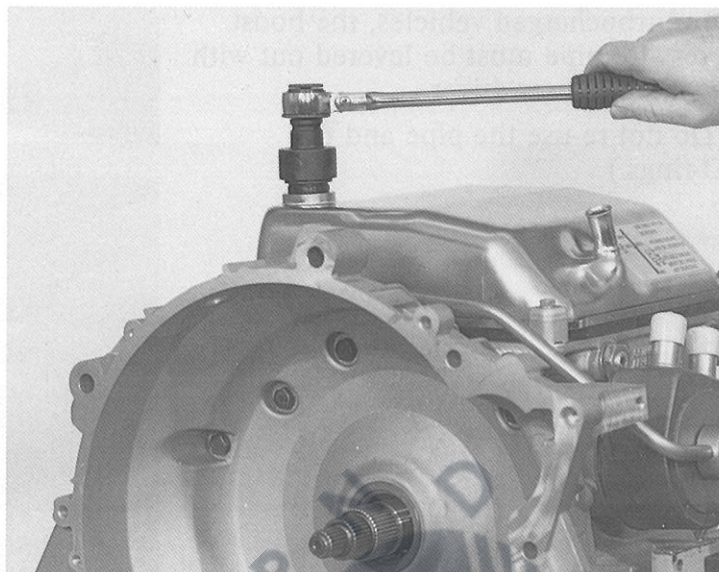

90005

Take off the oil cooler and pipe after  
removing the two hollow screws.  
(Wrench sizes = 19 and 27 mm.)  
Different versions may be installed.

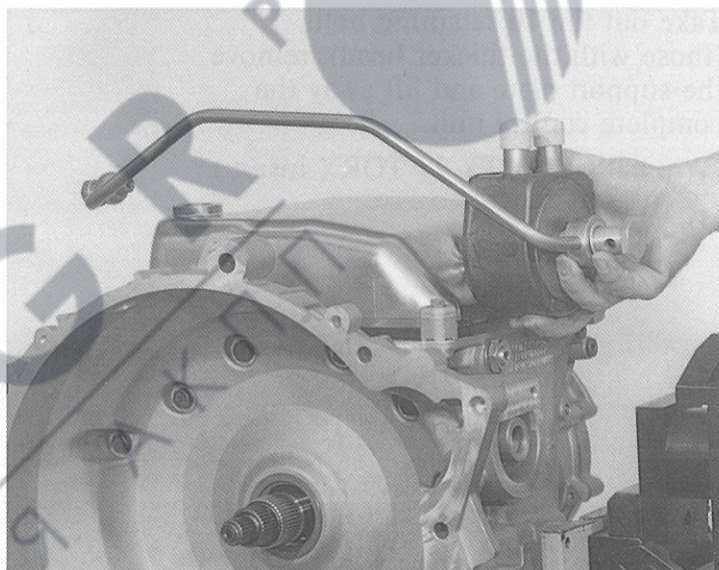

90006

Take out the screws holding the oil  
pan.  
Take off the oil pan with its gasket.  
(Wrench size = 10 mm.)

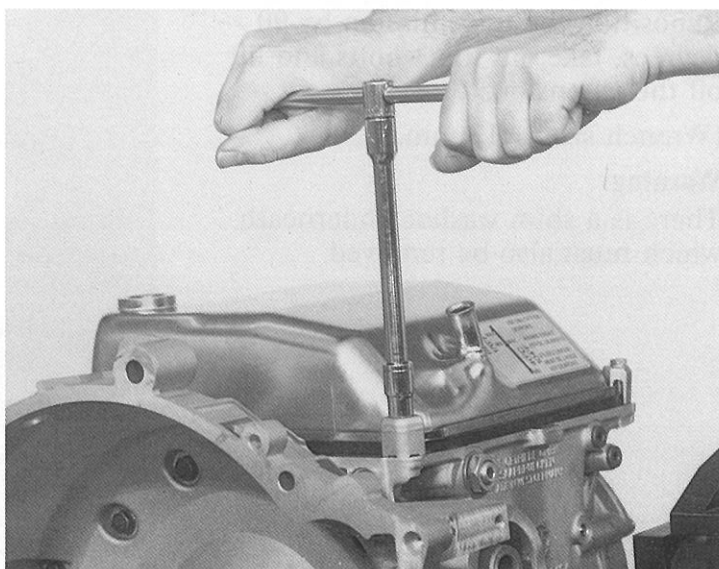



85092

On turbocharged vehicles, the boost pressure pipe must be levered out with a suitable screwdriver.

(Do not re-use the pipe and the O-rings.)

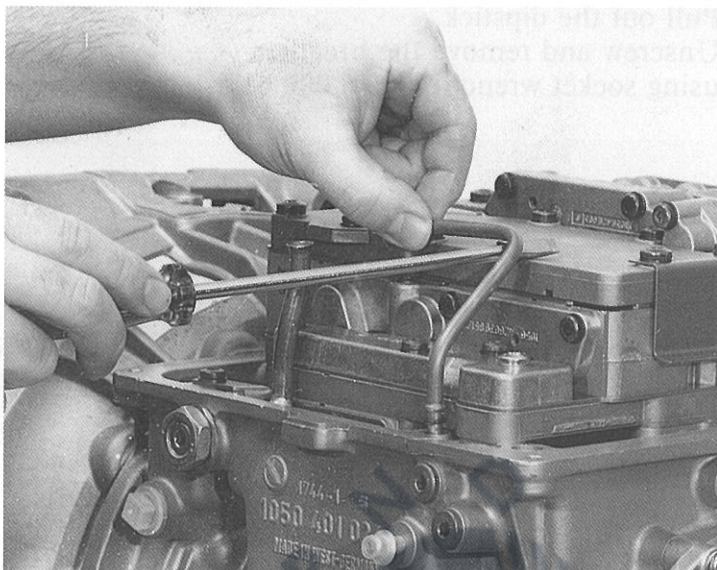

89012

Take out the 10 retaining bolts (those with the thicker head), remove the support plate and lift away the complete control unit.

(Wrench size = TX 27 TORX insert.)

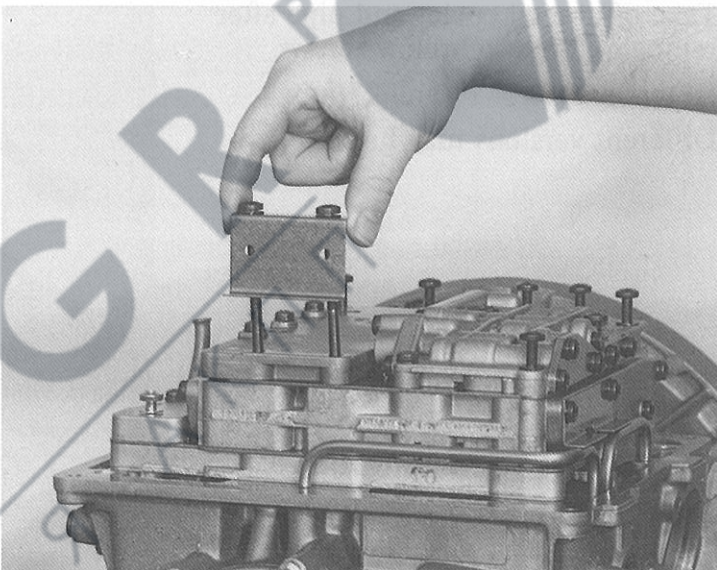

90007

Reposition the transmission by 90 degrees, take out the 3 bolts and lift off the extension.

(Wrench size = 13 mm.)

**Warning:**

There is a shim washer underneath which must also be removed.

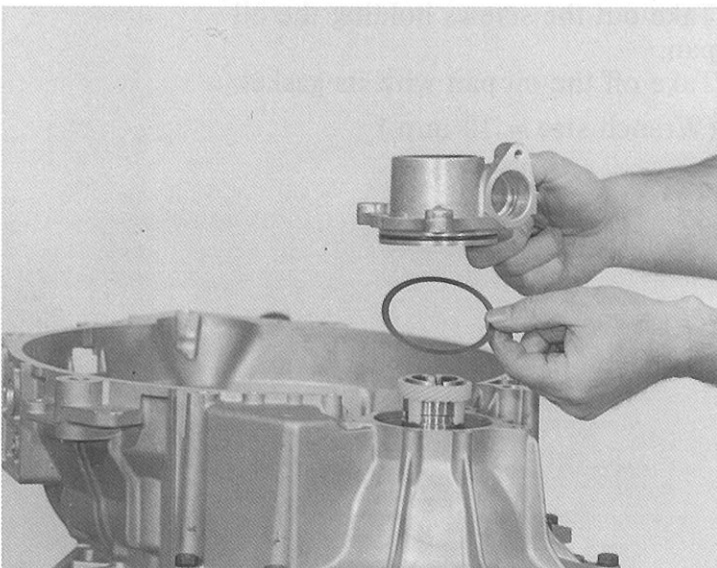



Take out the 18 hex bolts holding the bell housing. Remove the retaining plate at the same time.

(Wrench size = 13 mm.)

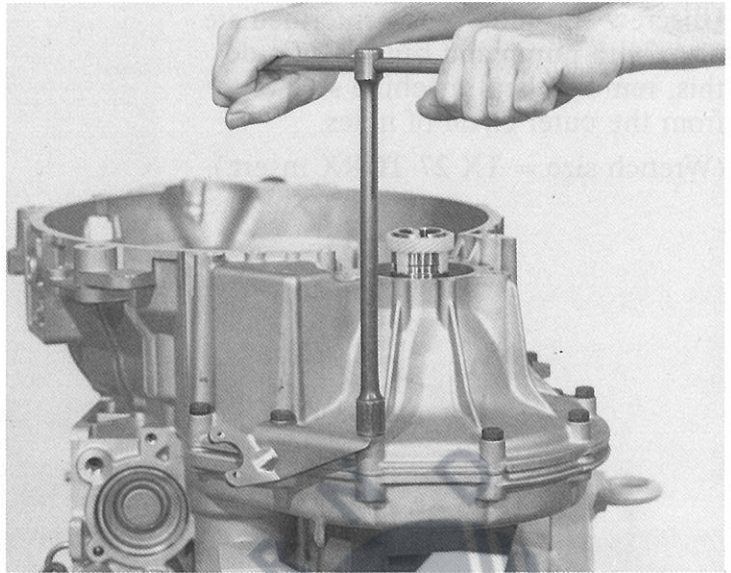

Lift off the complete bell housing. Remove the gasket.

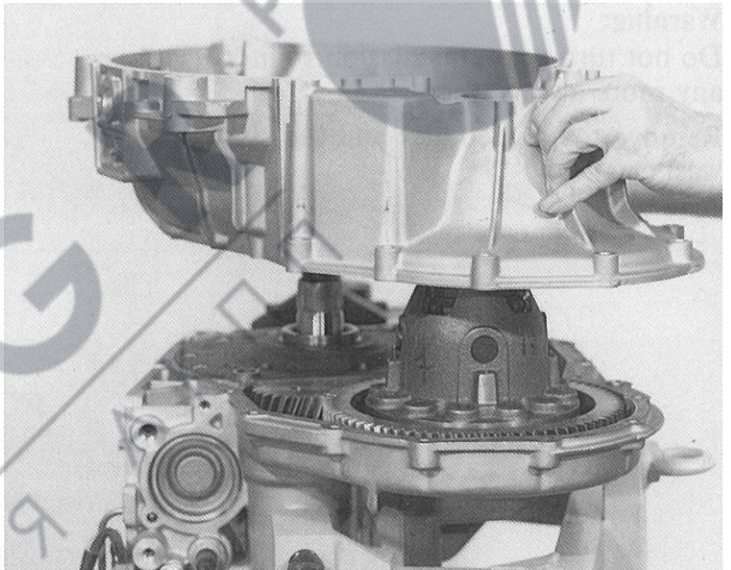

Lift off the complete differential.

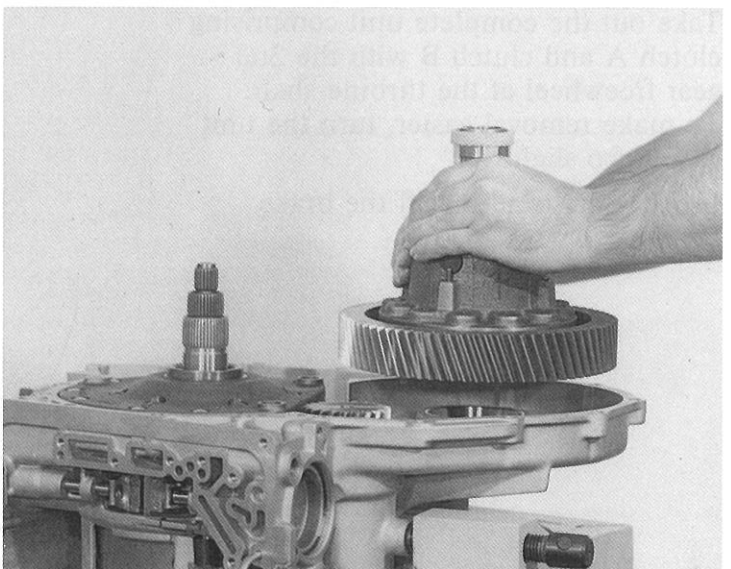



Unscrew and remove the intermediate plate with pump and brake C. To do this, remove the 8 machine screws from the outer circle of holes.

(Wrench size = TX 27 TORX insert.)

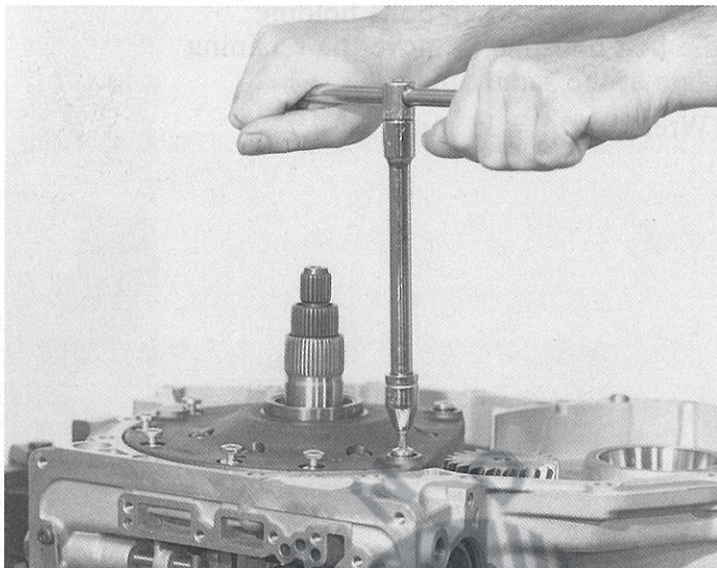

**Warning:**

Do not turn the transmission round any more at this stage.

Remove the angled disc and the shim washer(s).

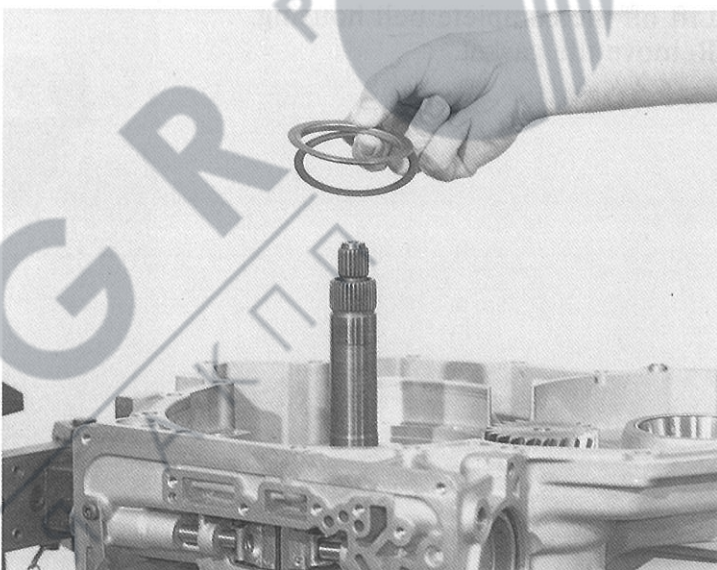

Take out the complete unit comprising clutch A and clutch B with the 2nd gear freewheel at the turbine shaft. To make removal easier, turn the unit to and fro slightly.

If necessary, slacken off the brake band.

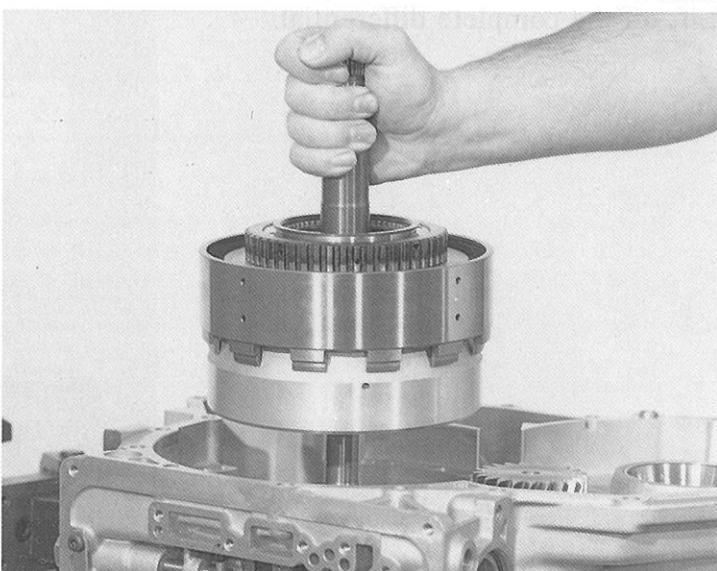

Remove the 2nd gear freewheel.

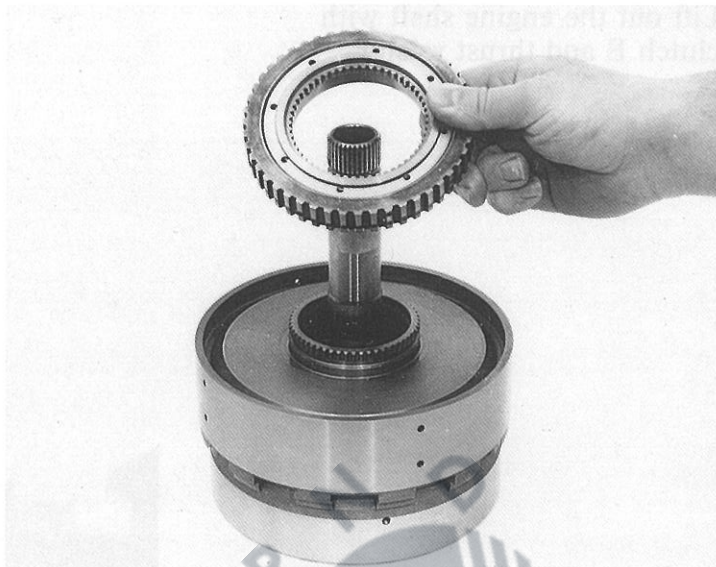

Lift clutch B away from clutch A.

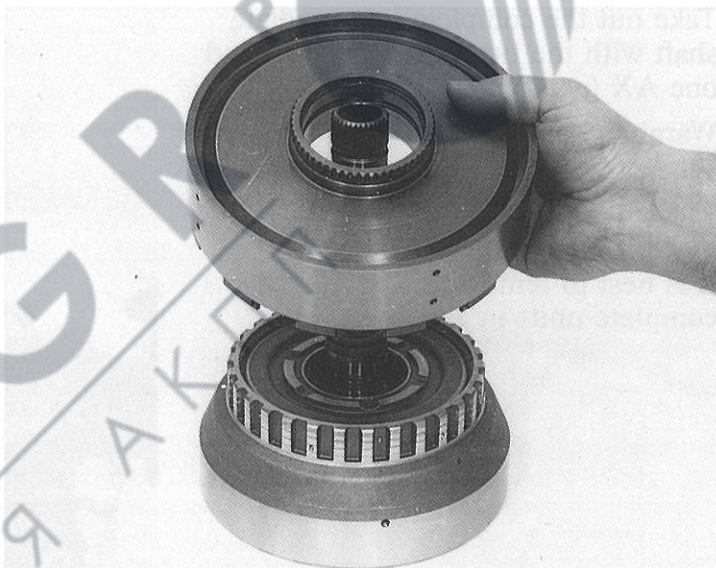

Take out the brake band opposite the brake plates.  
When removing, avoid bending the brake band outwards.

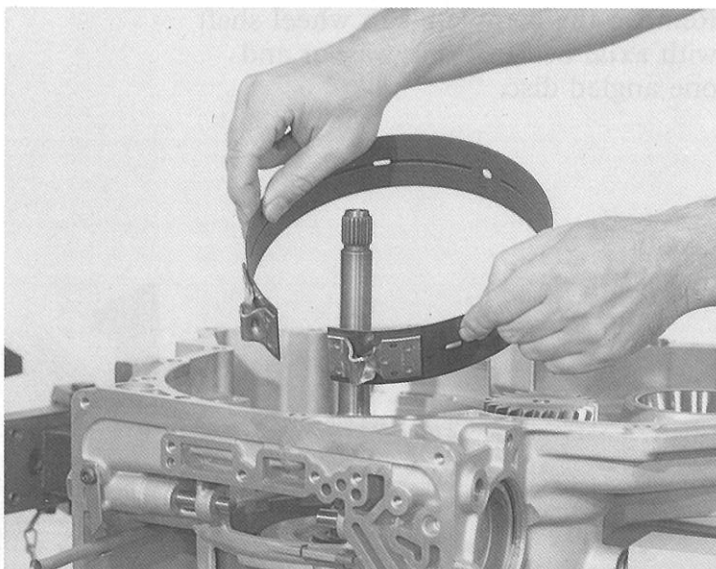



Lift out the engine shaft with clutch E and thrust washer.

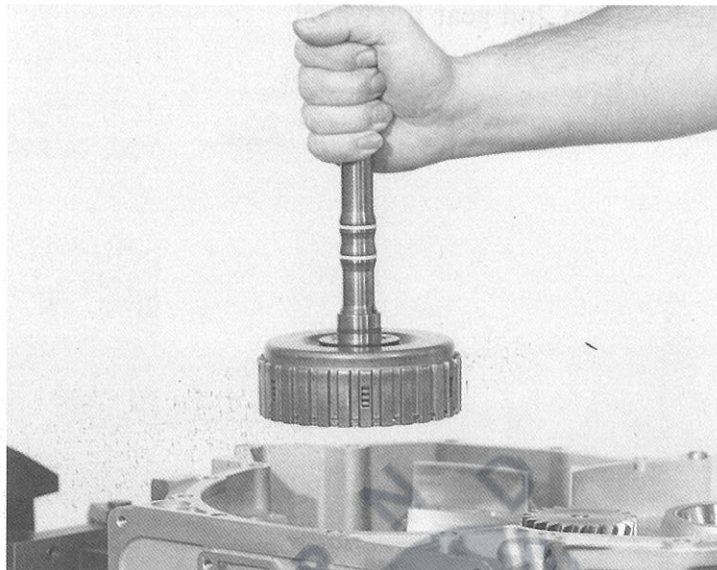

Take out the complete intermediate shaft with the two thrust washers and one AX (axial) needle roller cage.

**Warning:**

When removing AX bearings, the AX discs often stick to the opposite running surface.

It is best to remove the bearings as complete units in all cases.

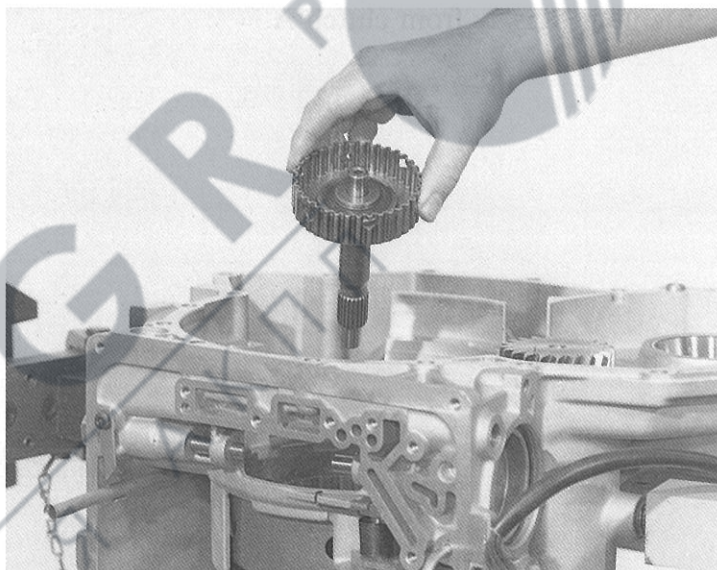

Remove the complete sun wheel shaft with axial bearing, one washer and one angled disc.

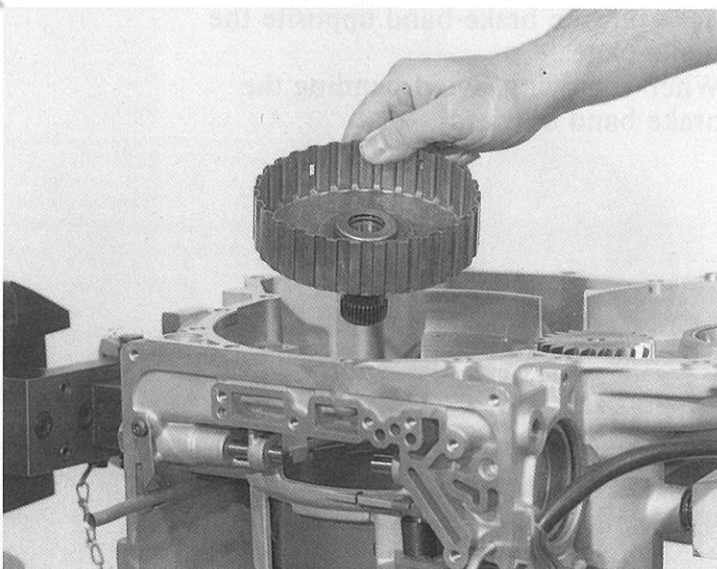

Take out the casing with axial bearing, washer and angled disc.

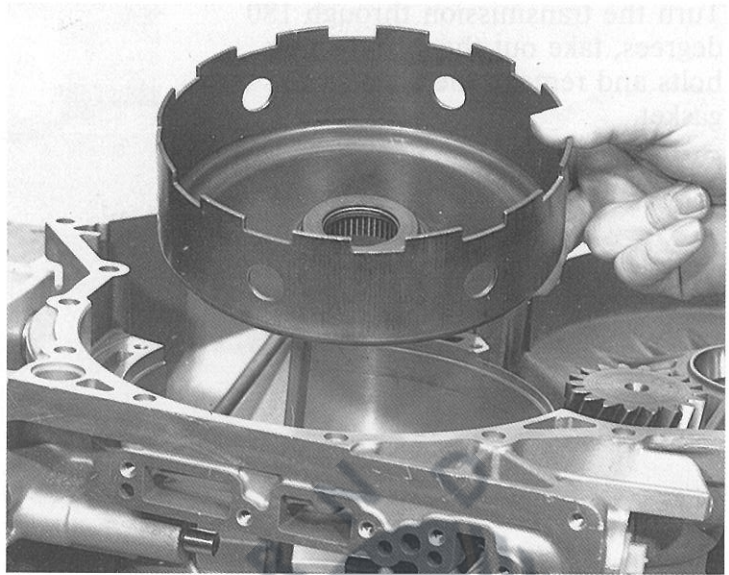

Lift off the sun wheel.

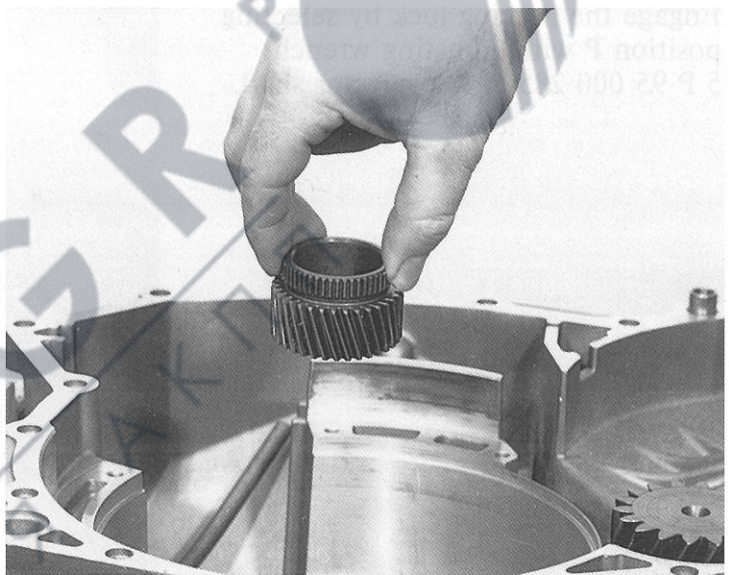

The planetary gear cluster plate complete with axial bearing, washer and angled disc can then be removed.

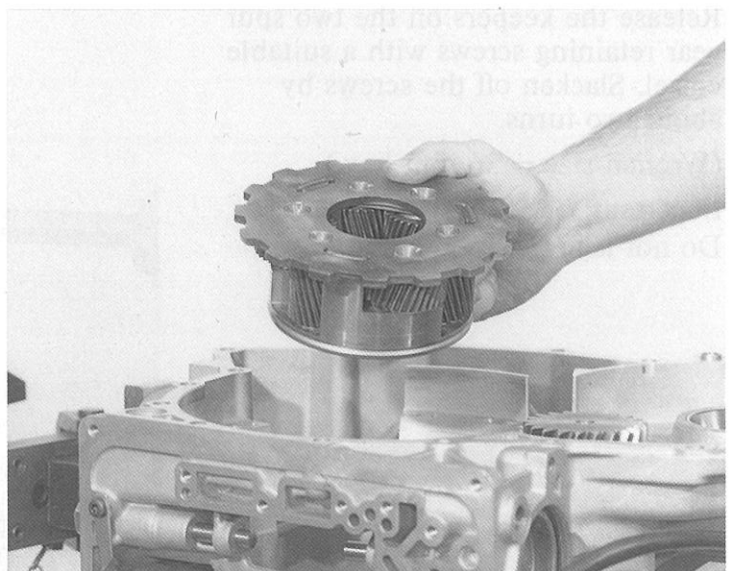



Turn the transmission through 180 degrees, take out the 13 retaining bolts and remove the cover with gasket.

(Wrench size = TX 27 TORX insert.)

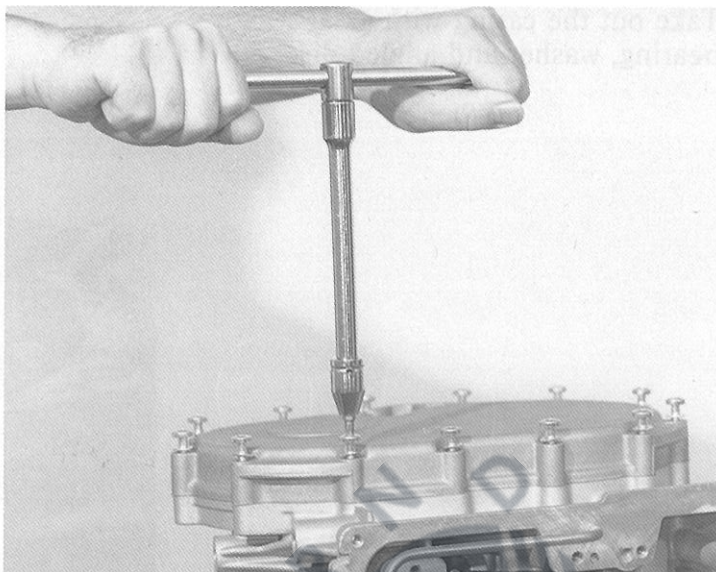

Engage the parking lock by selecting position P with adjusting wrench 5 P 95 000 285 at the selector shaft.

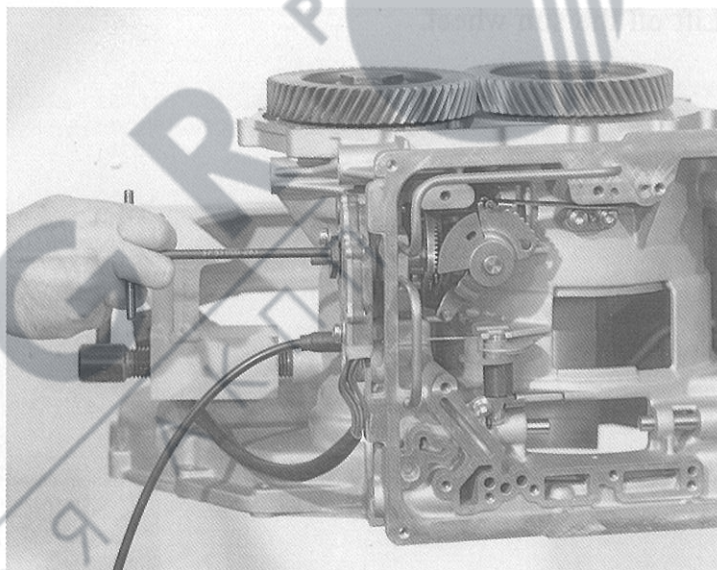

Release the keepers on the two spur gear retaining screws with a suitable chisel. Slacken off the screws by about two turns.

(Wrench size = 36 mm hex.)

**Important:**

Do not take the screws out.

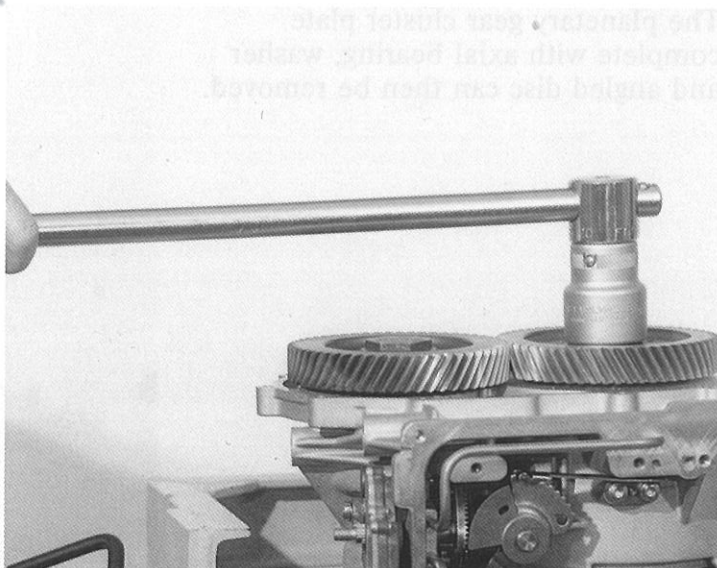



Turn the transmission through 90 degrees and release the parking lock. Take out the retaining bolt. The spur gear can then be taken off and the output shaft removed at the other side.

**Warning:**

There is a shim washer between the two parts.

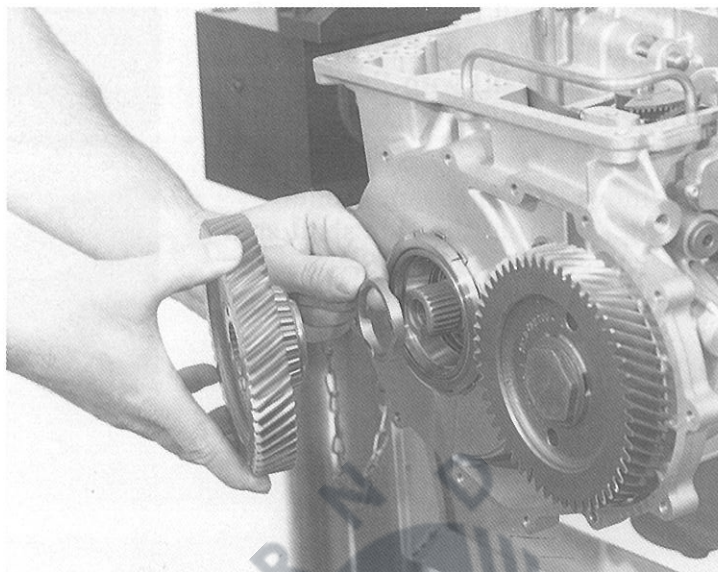

Remove the casing.

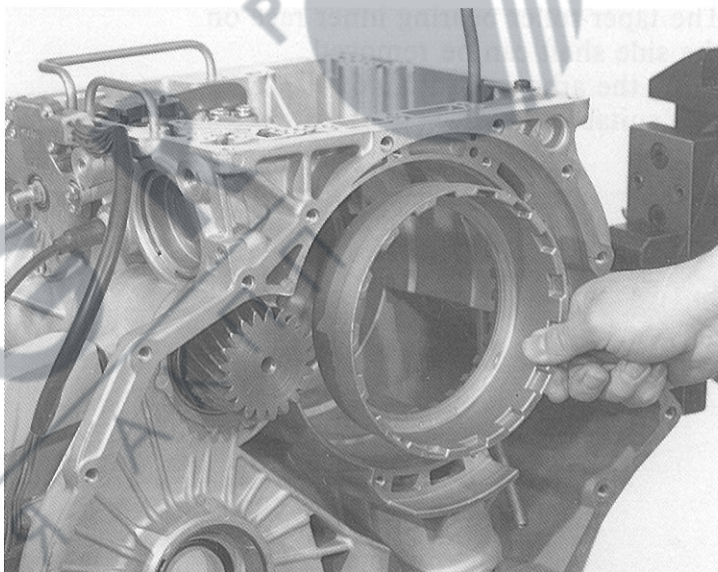

Remove the retaining screw fully. Pull the spur gear and shim washer off to one side and the side shaft to the other.

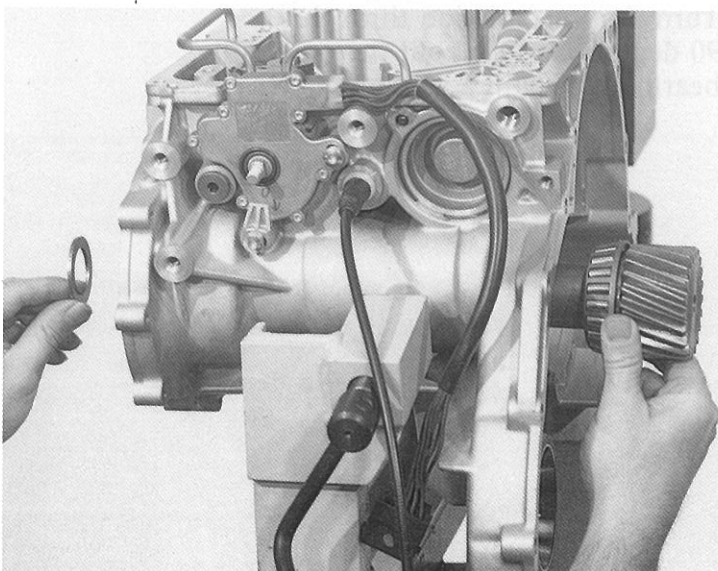



85116

If necessary, pull the inner race of the taper roller bearing off the spur gear (output shaft) with Rollex puller 48.500, screwed into basic unit 10001, 5 X 46 000 297.

To remove the inner taper roller bearing race from the side shaft spur gear, use gripper 503349/S.



85117

The taper roller bearing inner race on the side shaft can be removed, using the arbor, no. 5 X 46000328 in a suitable press.

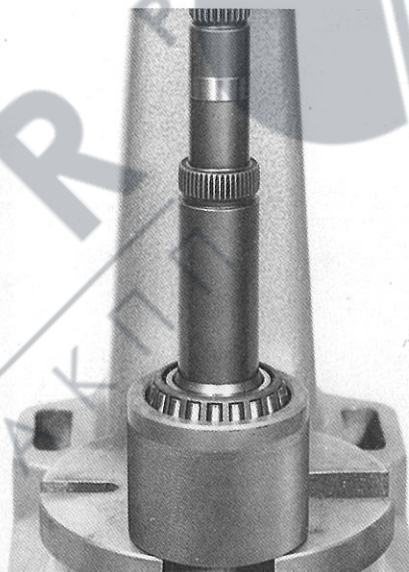

90025

Turn the transmission through 90 degrees and pull out the outer bearing race with a suitable puller.

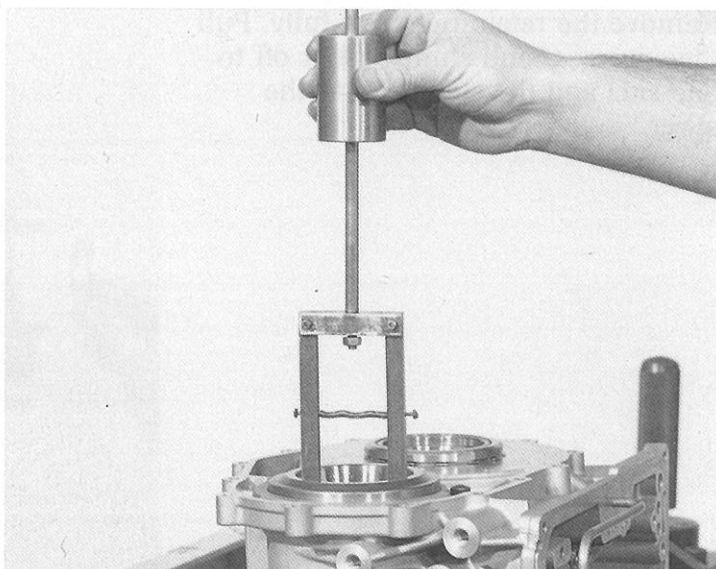

The spacing sleeve and the complete governor with flange can now be taken out.

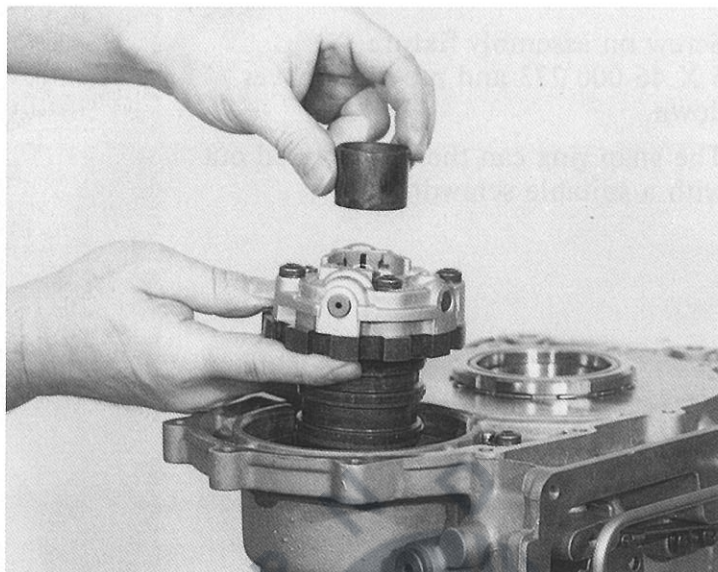

Turn the transmission through 90 degrees and remove the keeper plate from the slotted nut.  
Unscrew the slotted nut with wrench 5 X 46 000 155.  
Take off the slotted nut and keeper plate.

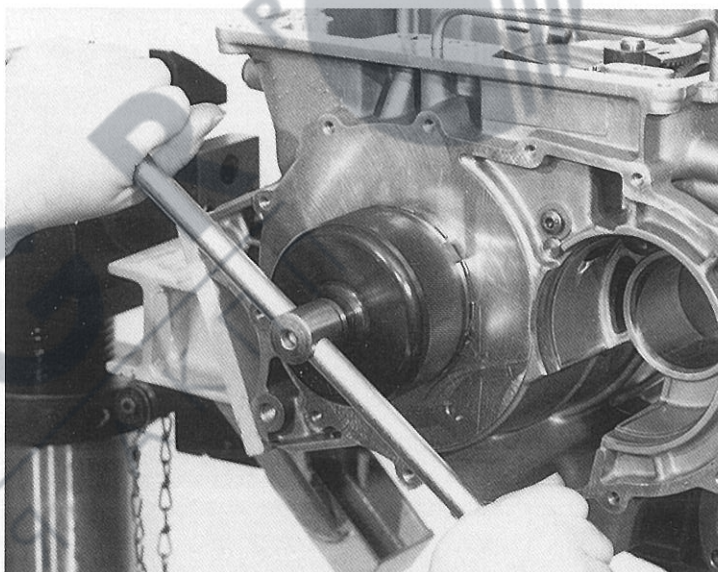

The bearing race with complete 1st gear freewheel can be pressed inwards and removed.

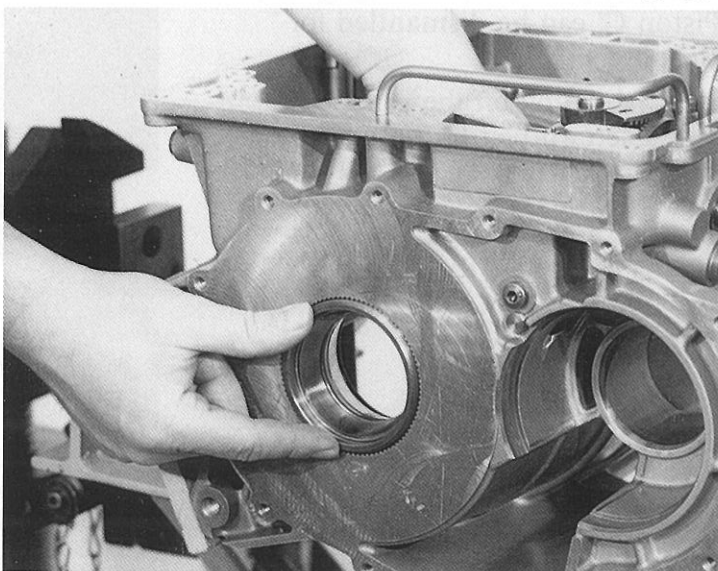



## 2.2 Brake C'

90026

Screw on assembly fixture  
5 X 46 000 273 and press the cover  
down.

The snap ring can then be levered out  
with a suitable screwdriver.

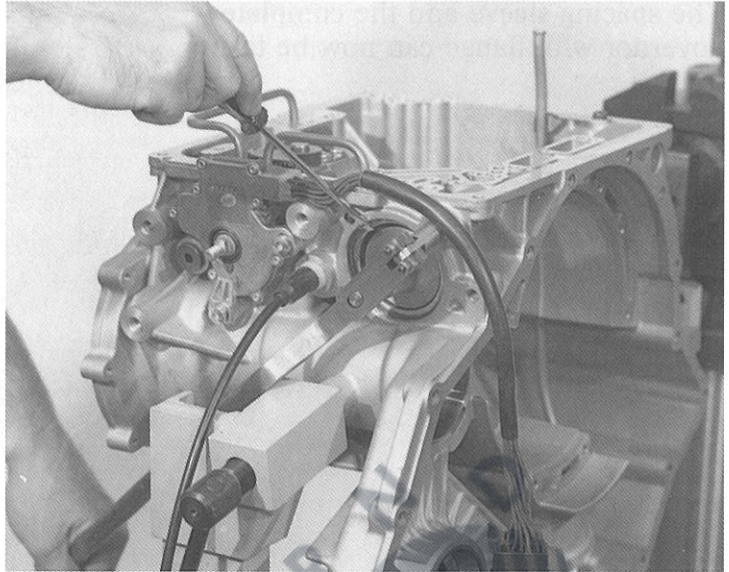

Take out the cover and complete  
piston C' with coil spring(s).

90027

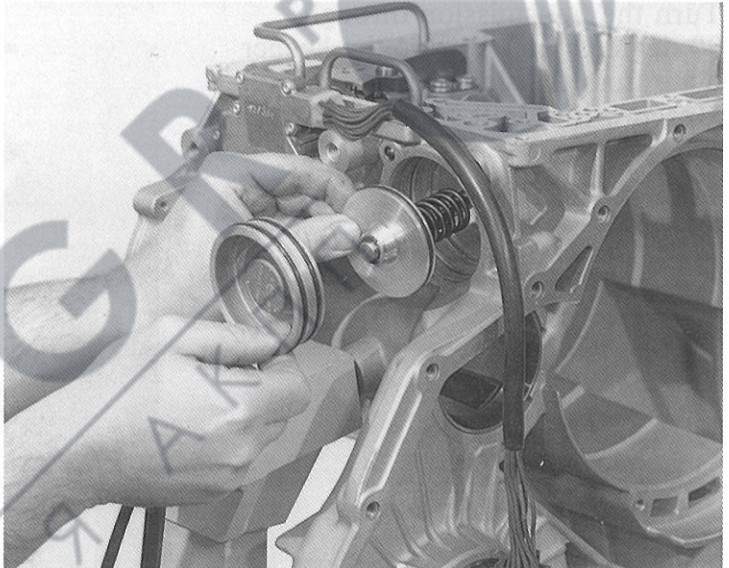

Piston C' can be dismantled for  
cleaning.

Pull the spring off the pin.  
Use a screwdriver to remove the  
circlip, then remove the piston and  
the two cup springs.

84072

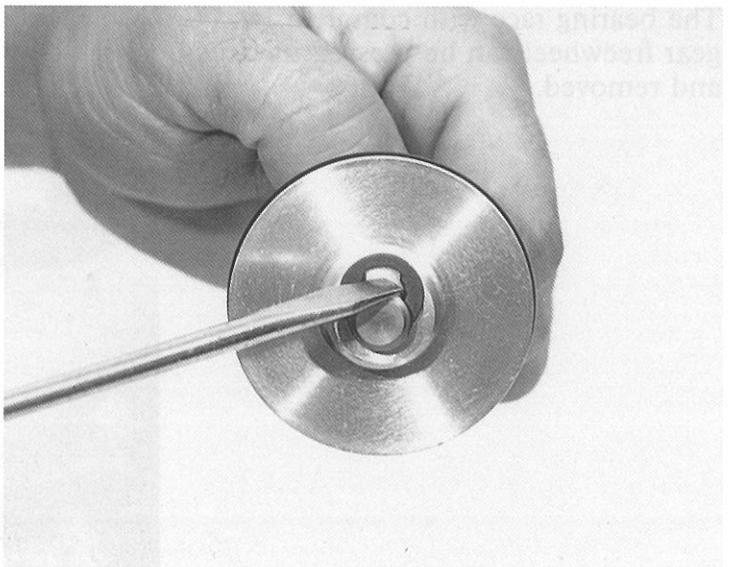



After unscrewing the locknut, the adjusting screw can be removed.  
 (Wrench size for locknut = 22 mm.)  
 (Wrench size for adjusting screw = 6 mm Allen key.)

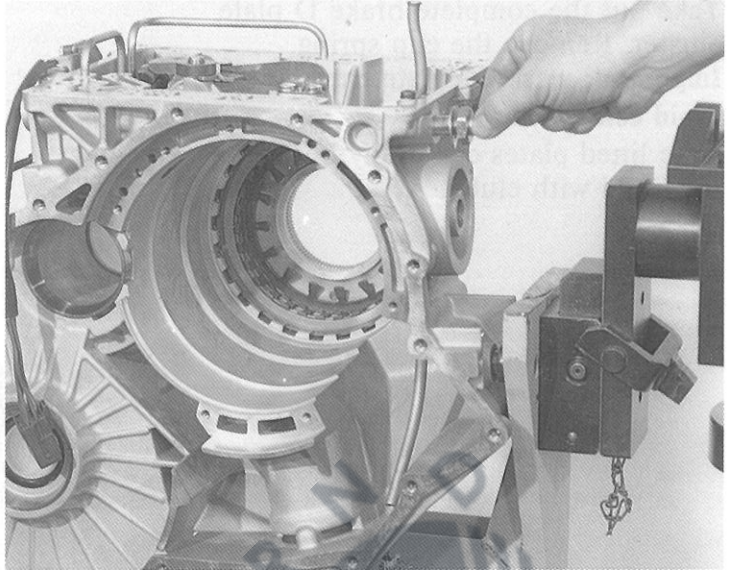

The pin can then be pulled out.

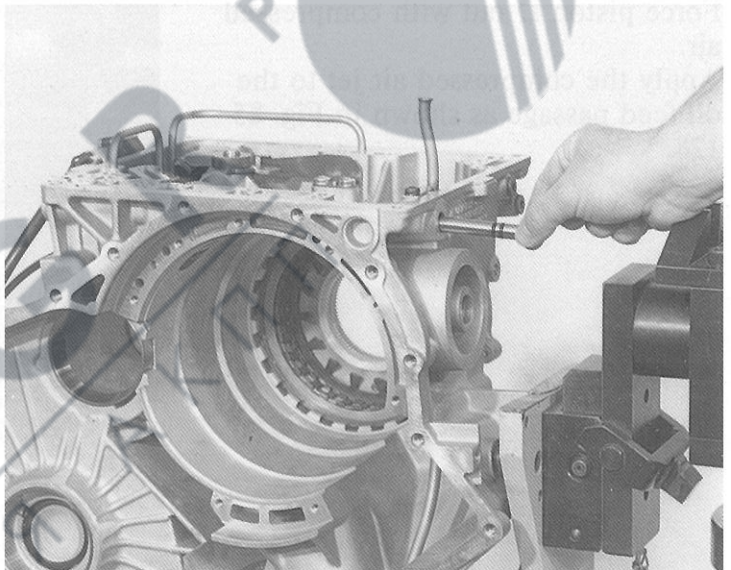

### 2.3 Brake D

Turn the transmission through 90 degrees.  
 Use two suitable screwdrivers to release the snap ring.

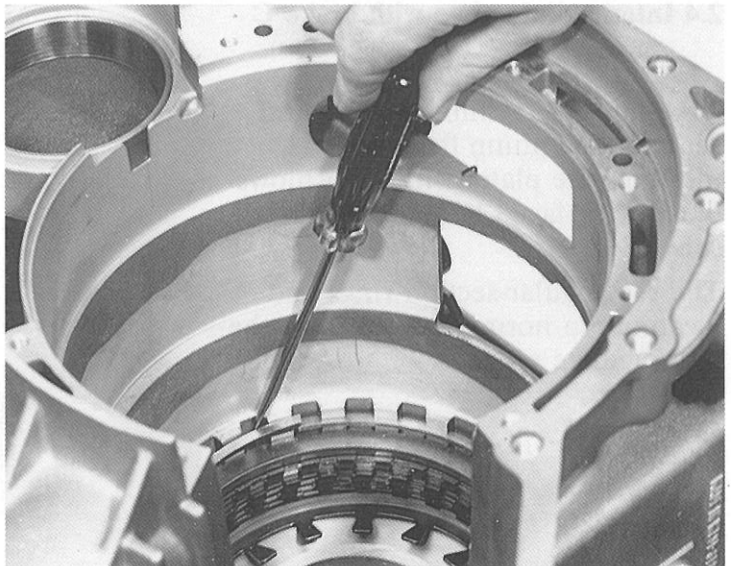



Take out the complete brake D plate cluster. Remove the cup spring.

**Important: mark the plate cluster to avoid confusion.**

(The lined plates can easily be confused with clutch A.)

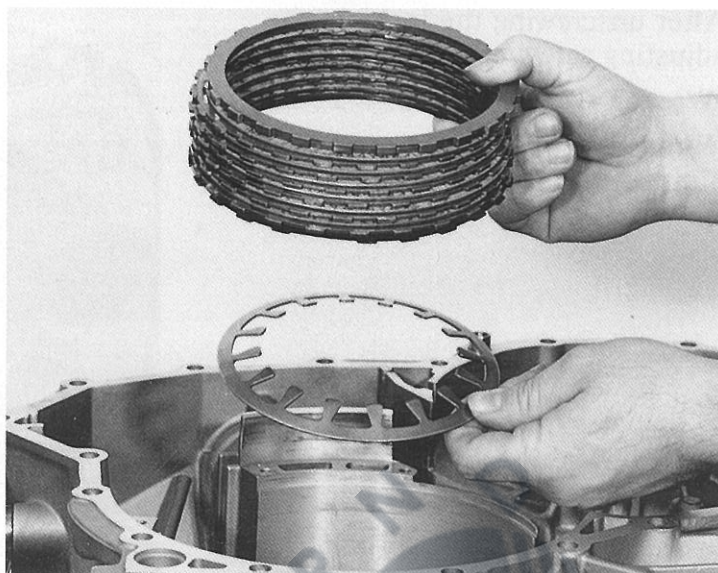

Force piston D out with compressed air.

Apply the compressed air jet to the oil feed passage as shown in Fig. 85 128.

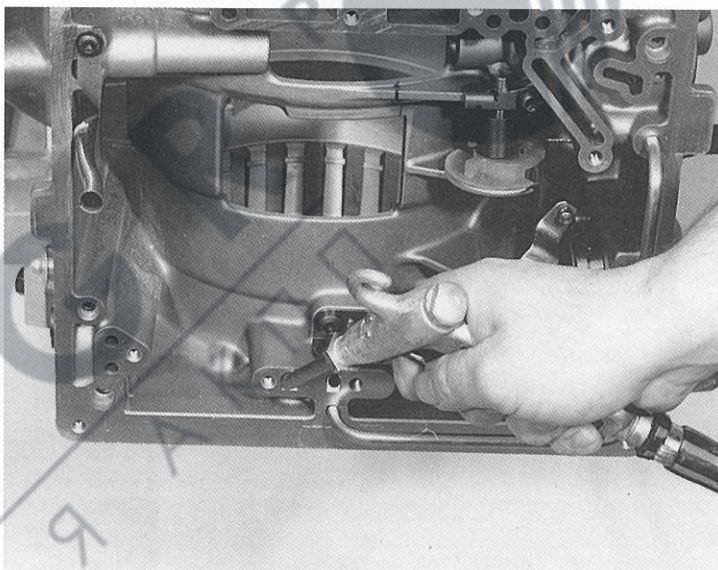

#### 2.4 Intermediate plate with brake C and pump

Take out the retaining screws and separate the pump from the intermediate plate (with light blows of a plastic-faced hammer at the side).

The rectangular-section rings and locating pin normally remain on the intermediate plate.

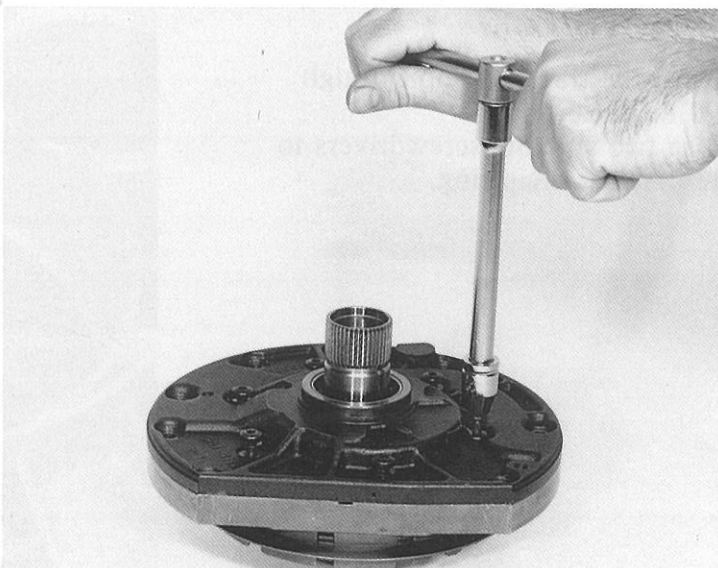



The pump can be dismantled by taking out the impeller and annulus.

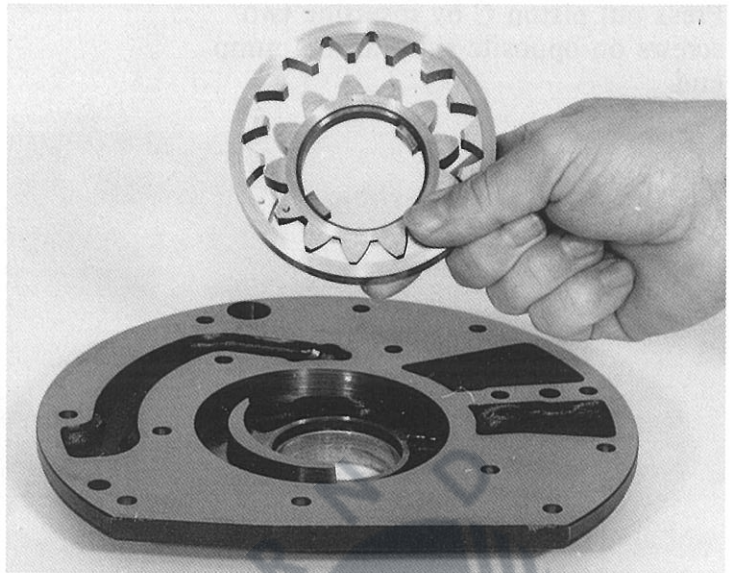

Remove the coil spring and the valve with cap from the intermediate plate.

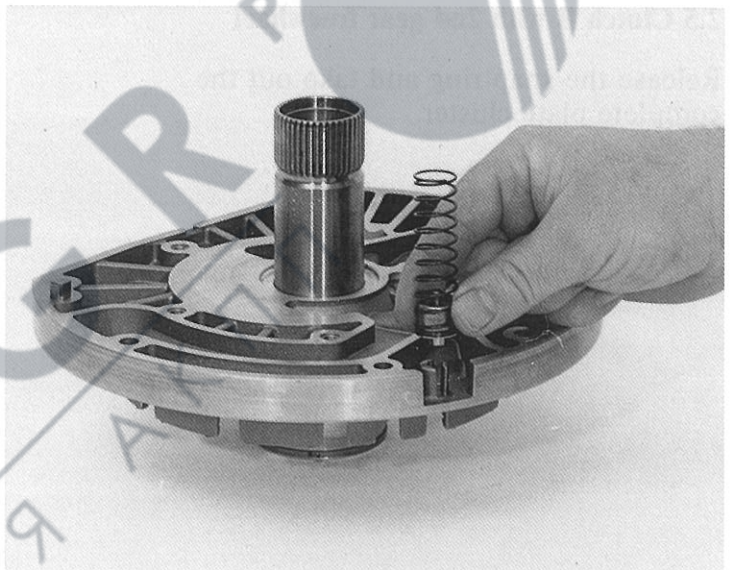

Disengage the snap ring from the groove and take out the complete brake C plate cluster with cup spring.

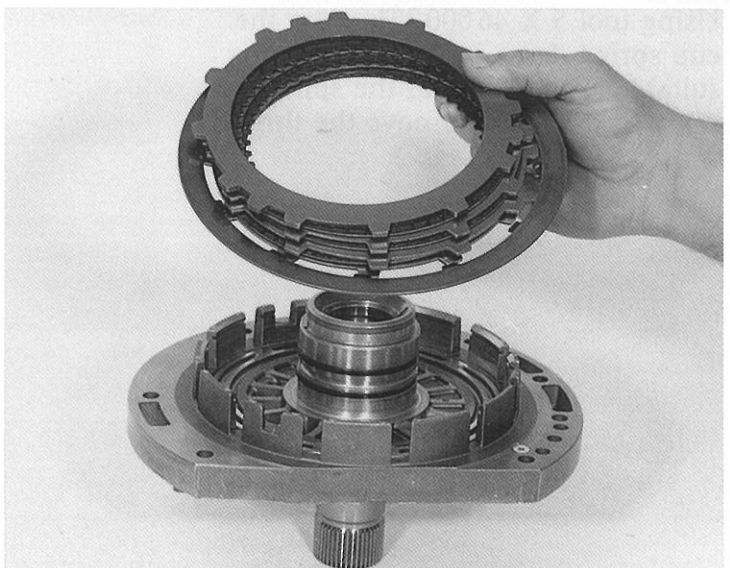



Press out piston C by inserting two screws on opposite sides at the pump end.

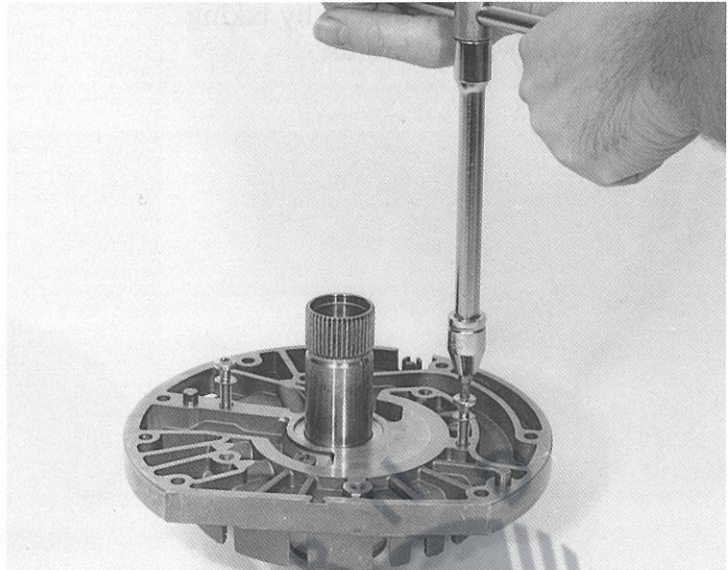

### 2.5 Clutch B with 2nd gear freewheel

Release the snap ring and take out the complete plate cluster.

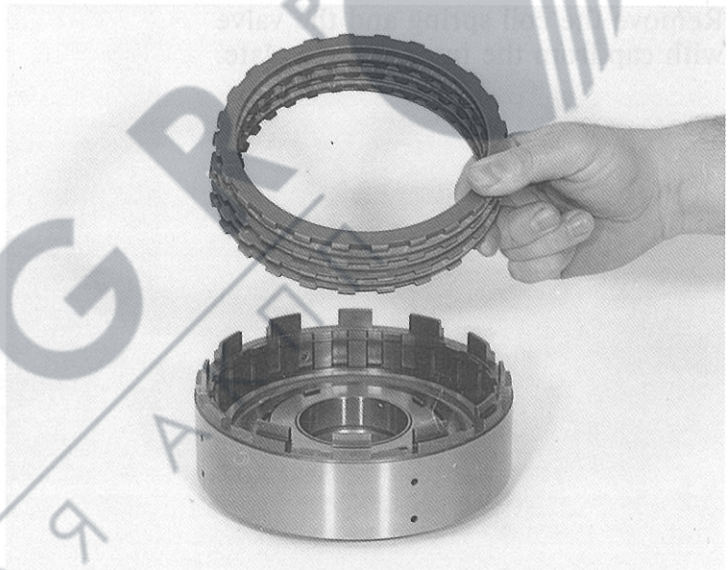

Using tool 5 X 46000221, press the cup spring down in the press with a suitable arbor, pull out the split retaining ring and remove the thrust washers.

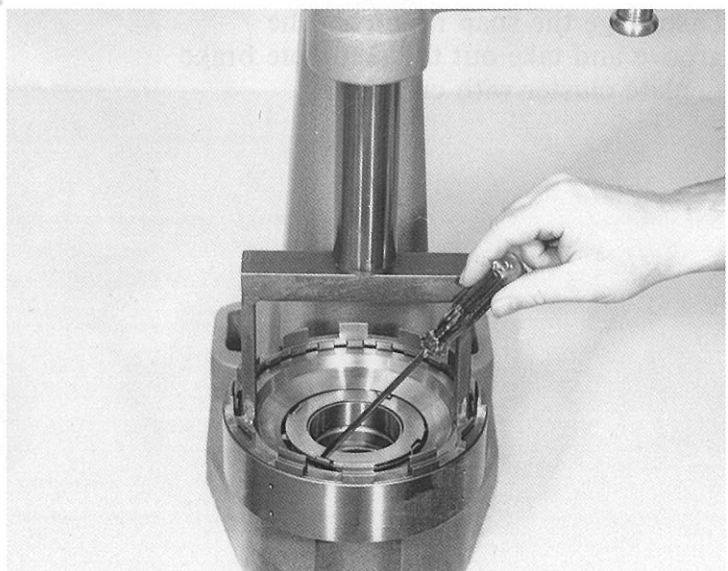

Take out the cup spring.

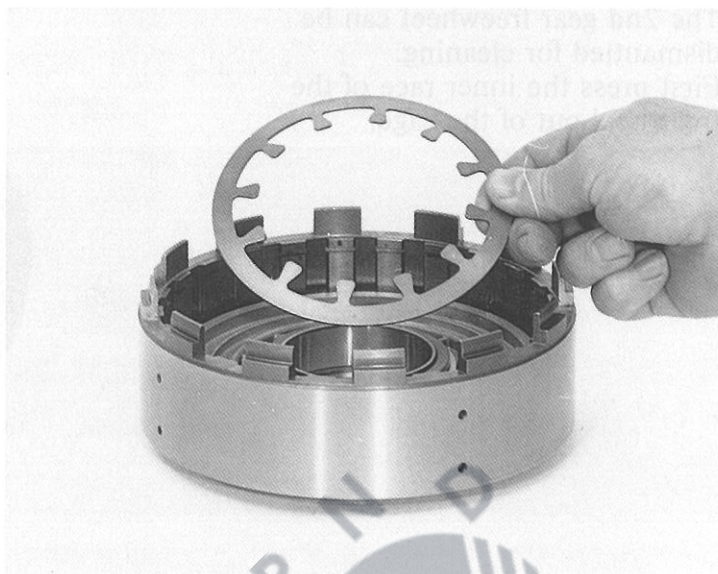

Apply a compressed air jet to the oil feed hole and press out piston B.

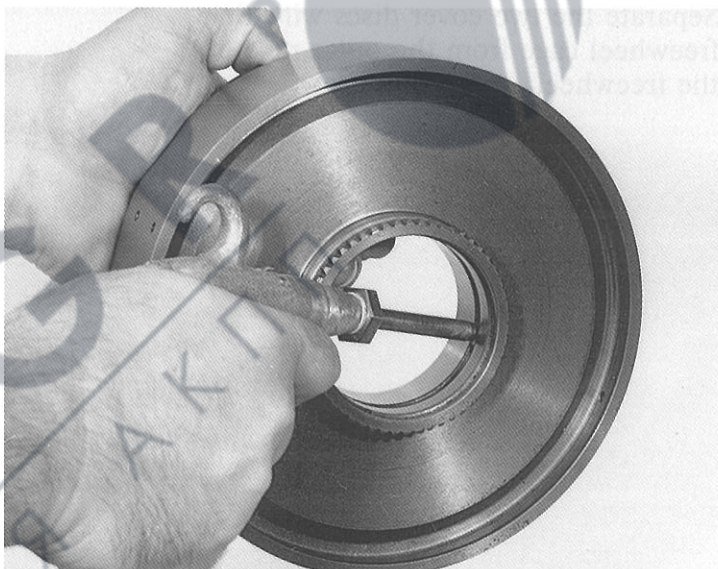

Press the intermediate ring out of the piston.

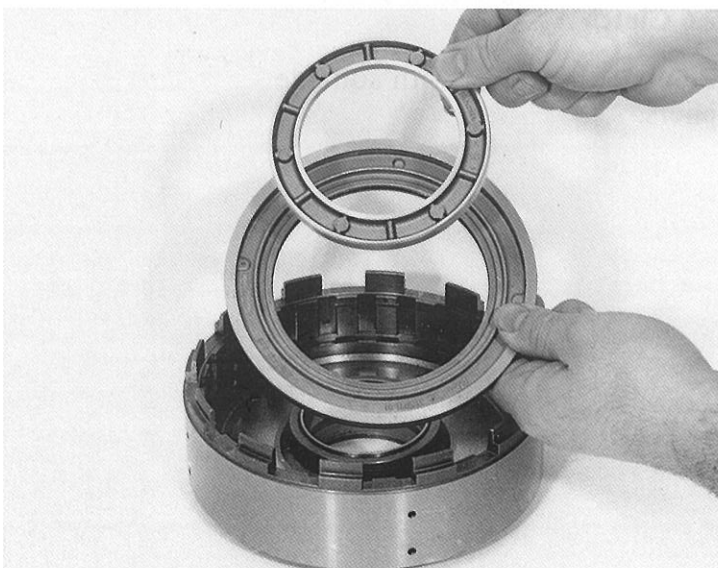



The 2nd gear freewheel can be dismantled for cleaning. First press the inner race of the freewheel out of the cage.



Separate the two cover discs with the freewheel cage from the outer race of the freewheel.

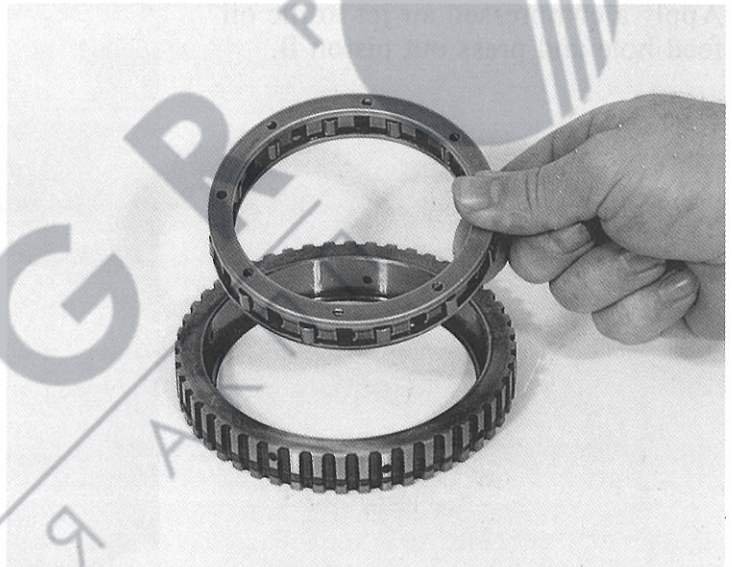

## 2.6 Clutch A

Remove the circlip with suitable pliers.



The turbine shaft can now be pulled out towards the drive end.



Remove the snap ring from the cylinder and take out the complete plate cluster including the spring plate. **Important: mark the plate cluster.** (The lined plates can easily be confused with brake D.)

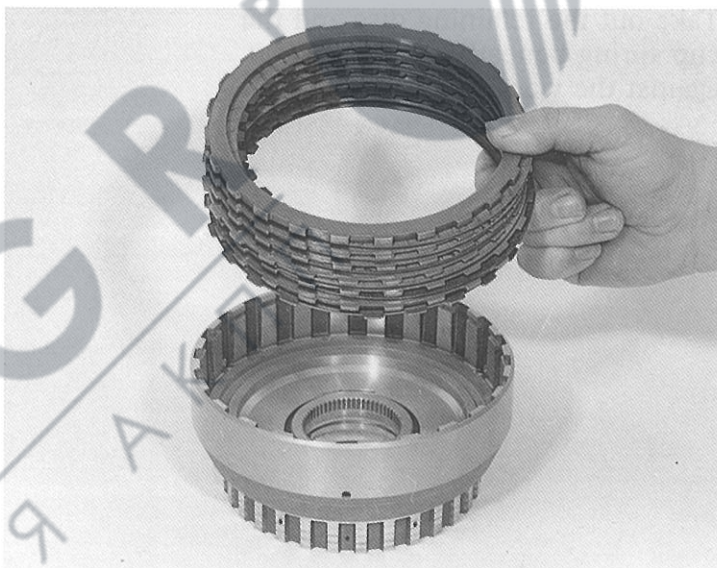

Using the hoop of tool 5 X 46 000 167, press down the retaining disc in the arbor press and release the circlip with suitable pliers and a screwdriver.

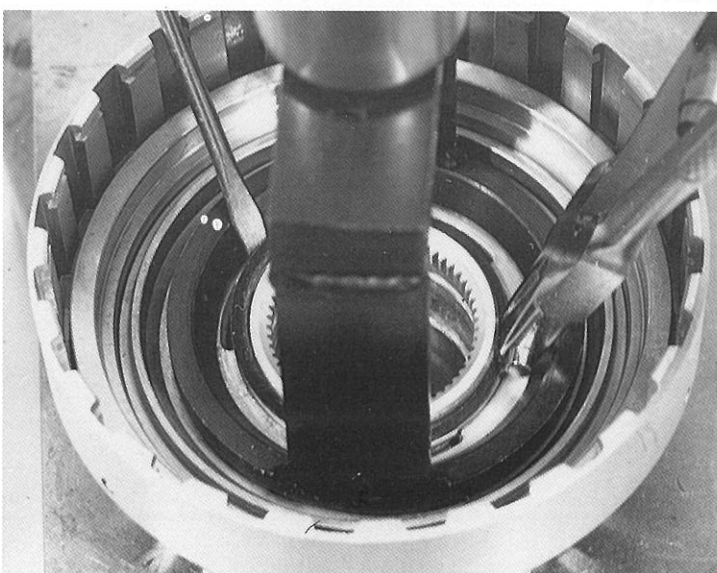



Apply a compressed air jet to one of the two oil feed holes, seal off the open oil feed holes with the fingertips and press out piston A.

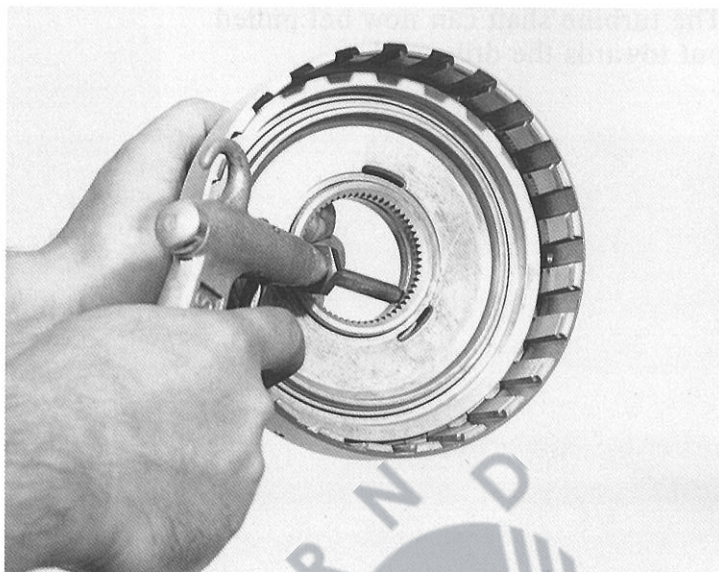

Take out the retaining disc and the cup spring beneath it by striking it against the workbench lightly.



### 2.7 Clutch E

Take the thrust washer off the engine shaft.

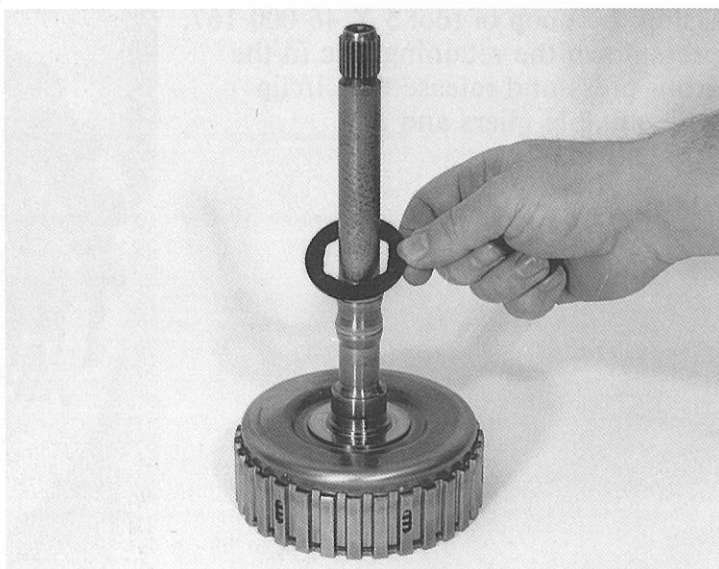

Release the snap ring and take out the complete plate cluster.

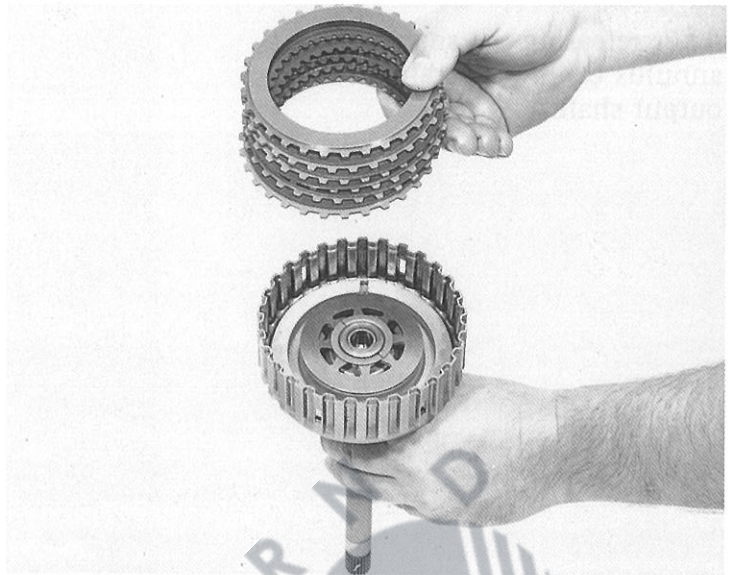

Using mounting fixture 5 X 46000148, press cup spring E fully down in the arbor press, take out the divided retaining ring and remove the cup spring.

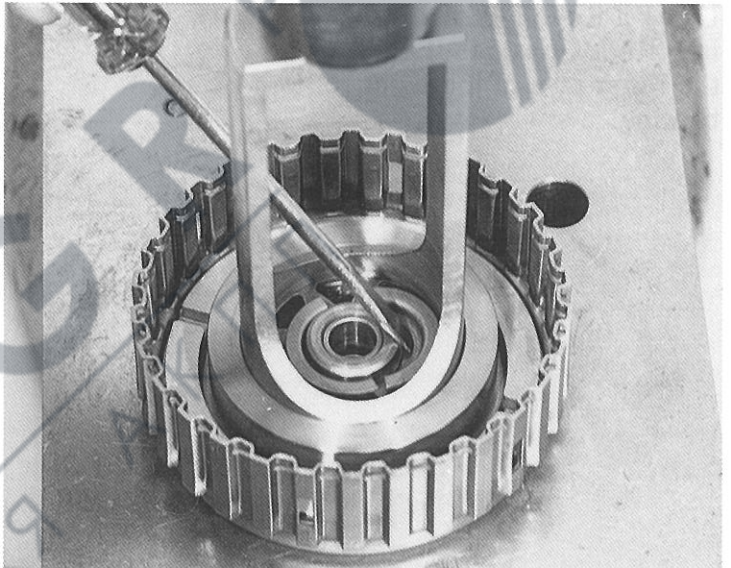

Use a compressed air jet at the oil feed hole to force out piston E.  
The rectangular-section rings normally remain on the engine shaft.  
**Note:** the white plastic rings have angled ends.

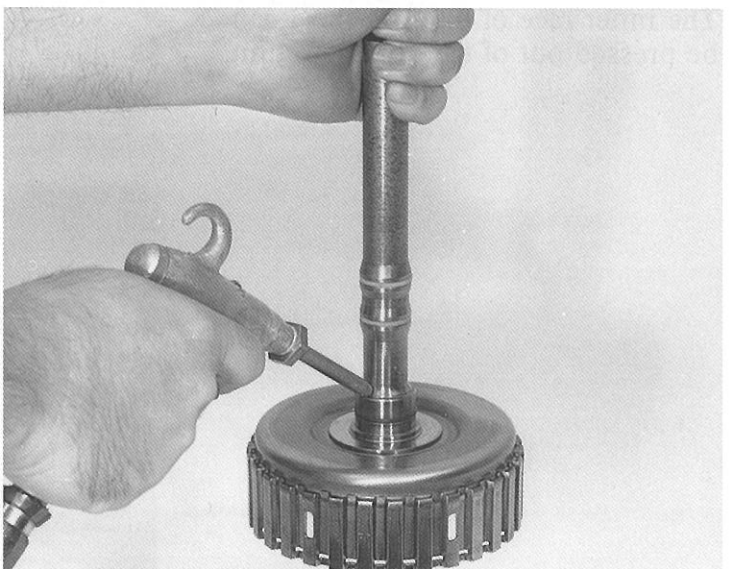



## 2.8 Output shaft and 1st gear freewheel

84 099

After releasing the snap ring, the annulus can be separated from the output shaft.

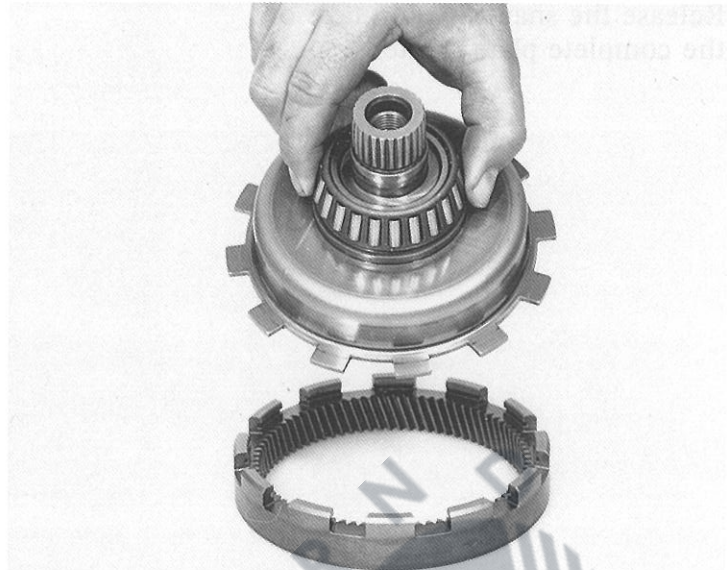

Using a Rollex 48.500 puller screwed into Rollex basic unit 10001, pull off the inner race of the taper roller bearing.

84 100

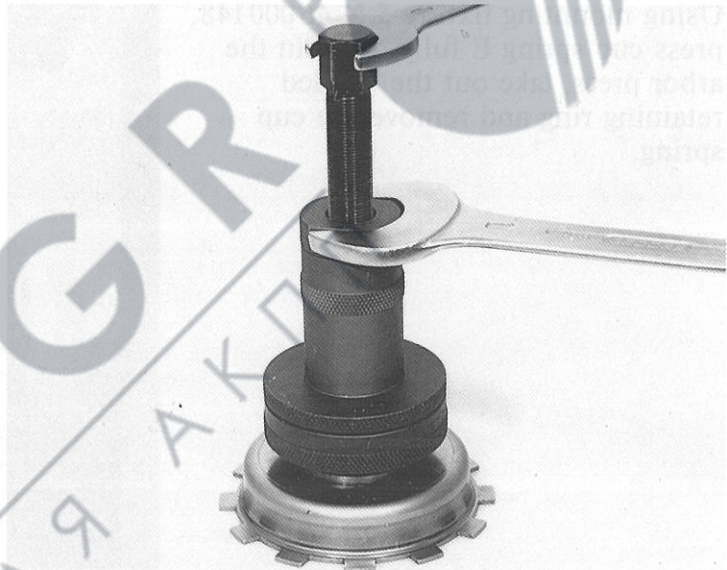

The inner race of the freewheel can be pressed out of the complete unit.

90 030

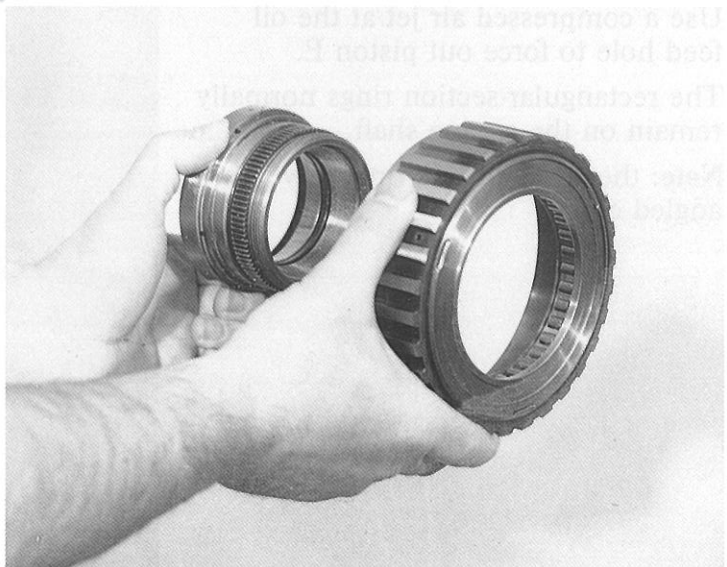

If the bearing or the inner freewheel race are damaged, the two outer races of the taper roller bearings can be pulled off with a Kukko Size 21/7 puller screwed into reaction support Size 22/2.

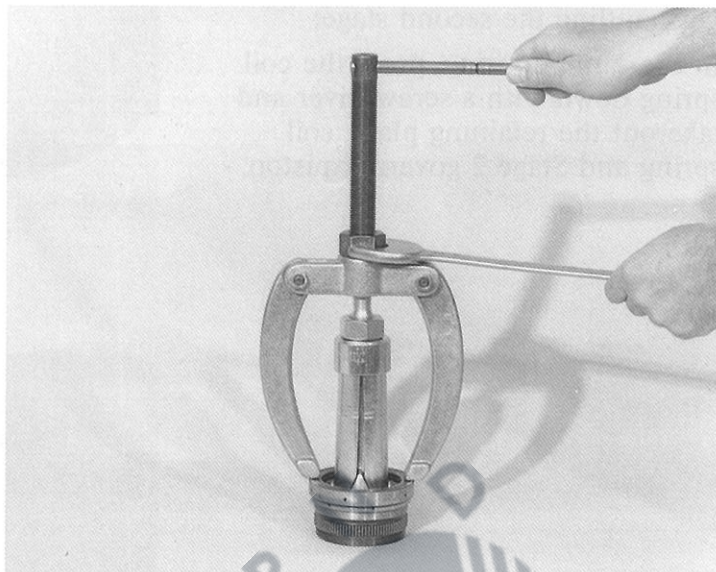

## 2.9 Governor and differential

Take out the 5 machine screws and separate governor housings I and II from the governor hub.

(Wrench size = TX 27 TORX insert.)

87034

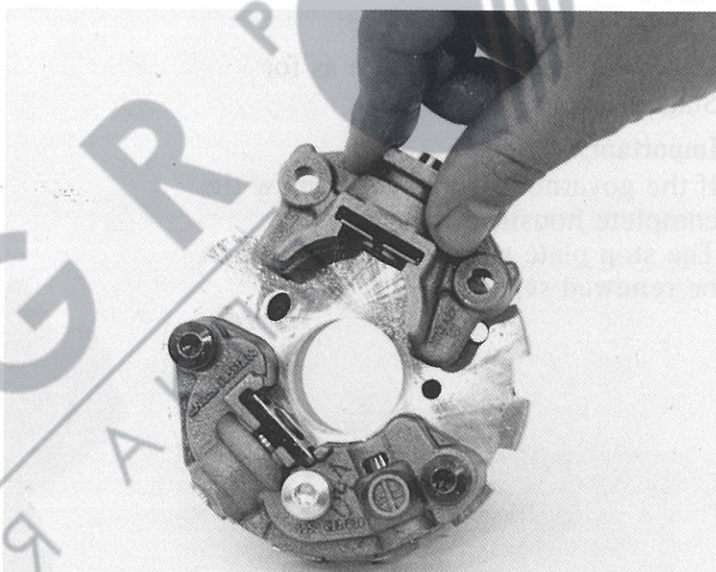

Dismantling the first stage:

Pull off the stop plate and press out the Stage I governor piston.

88053

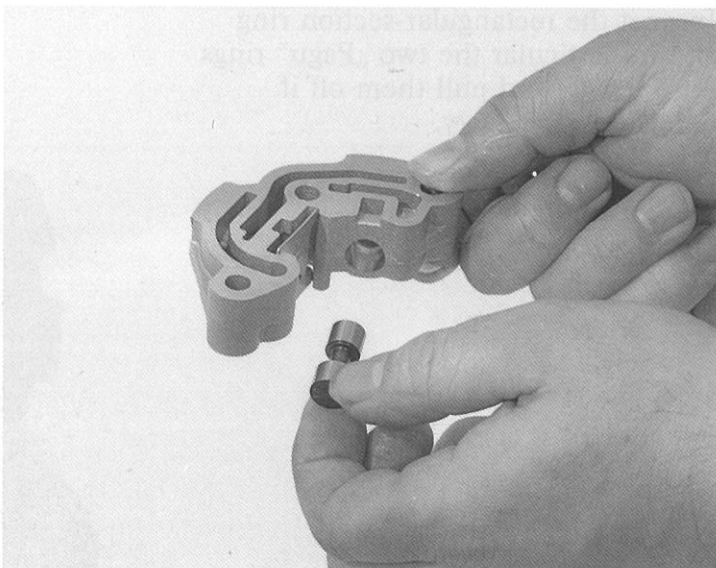



Dismantling the second stage:

In the same housing, press the coil spring down with a screwdriver and take out the retaining plate, coil spring and Stage 2 governor piston.

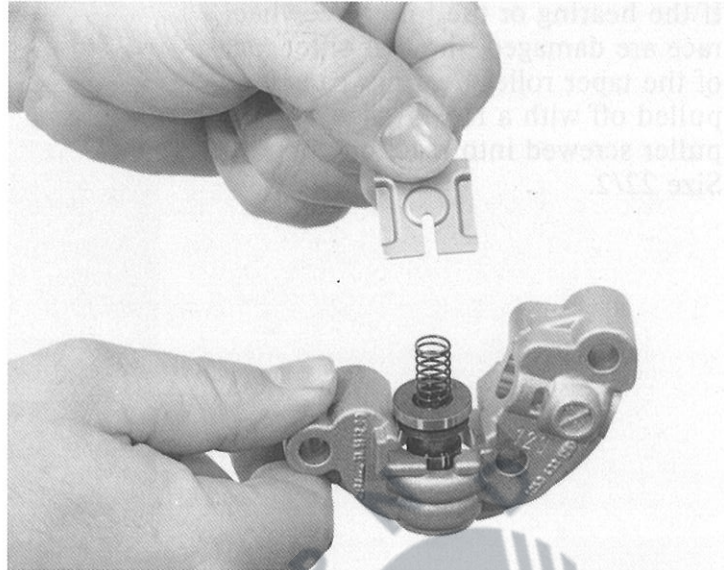

Dismantling the third stage:

Follow the same procedure as for Stage 2.

**Important:**

If the governor is damaged, renew the complete housings.

The stop plate and retaining plate can be renewed separately.

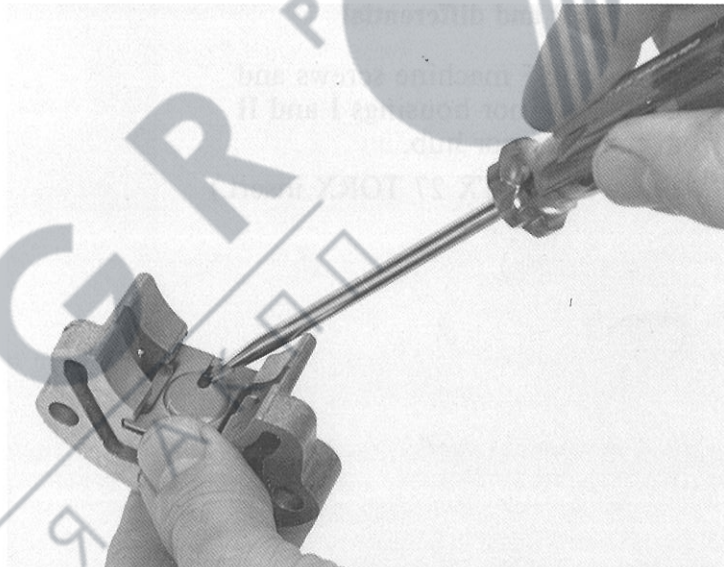

Inspect the rectangular-section ring and in particular the two „Pagu” rings for damage, and pull them off if renewal is necessary.

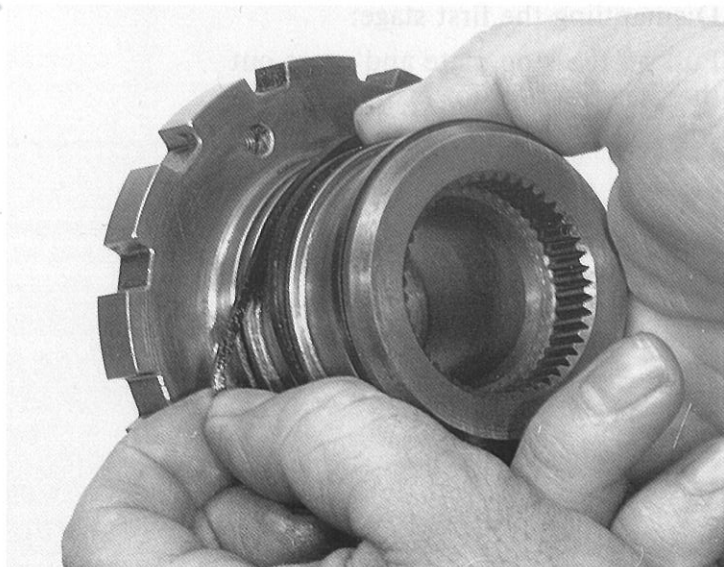

Lever off the speedometer drive worm with a screwdriver.

**Important:**

The steel version of the speedometer drive worm must not be dismantled (safety part).

If the differential is defective, it must be renewed as a complete unit.

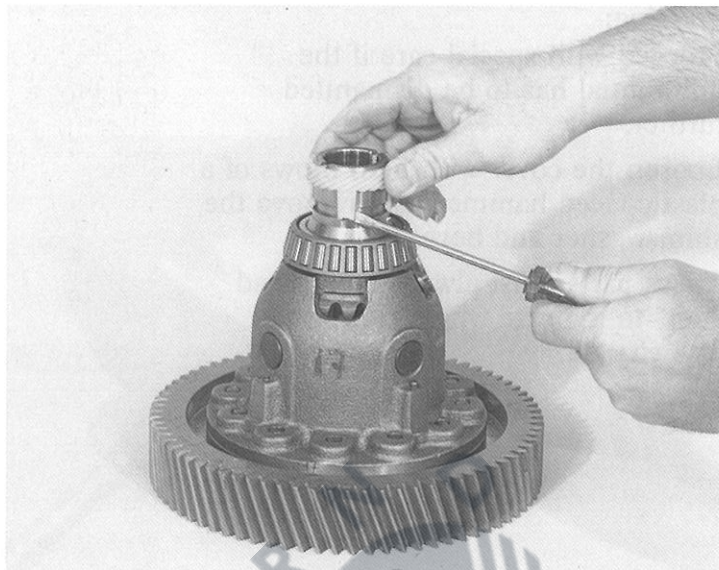

Using Rollex Super gripper 503349/I screwed into Rollex IA basic unit, together with core insert 5 X 46 000 297, pull both taper roller bearing inner races off the differential cage.

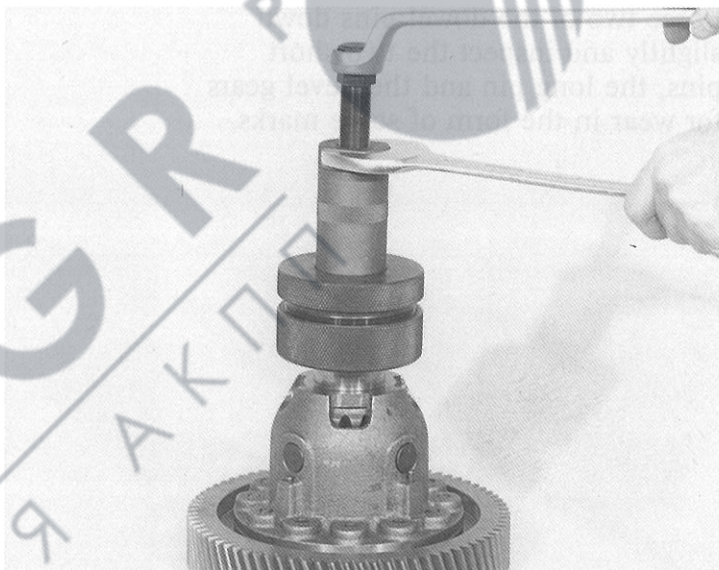

Clamp the differential into a vice and take out the 12 retaining bolts.

The spur gear can then be separated from the differential.

(Wrench size = 17 mm.)

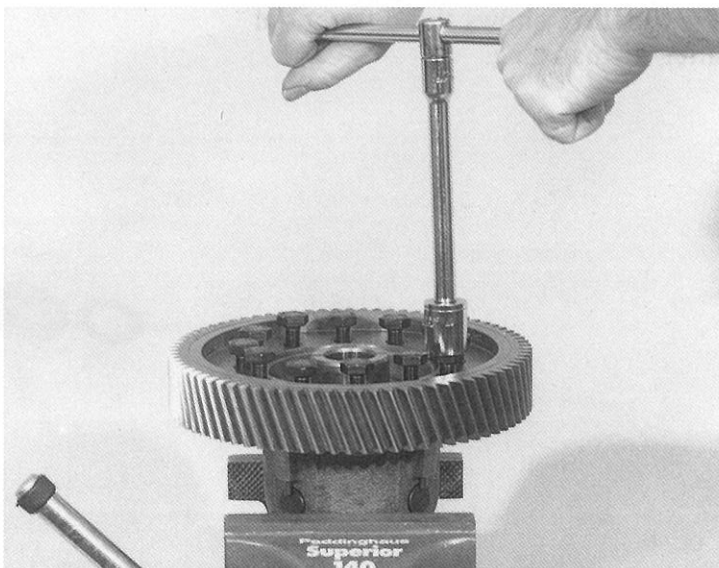



**Warning:**

Proceed with special care if the differential has to be dismantled further.

Loosen the cover with light blows of a plastic-faced hammer, and remove the shim washer and bevel gear.

These parts must always be marked „top” to indicate where they are to be installed.

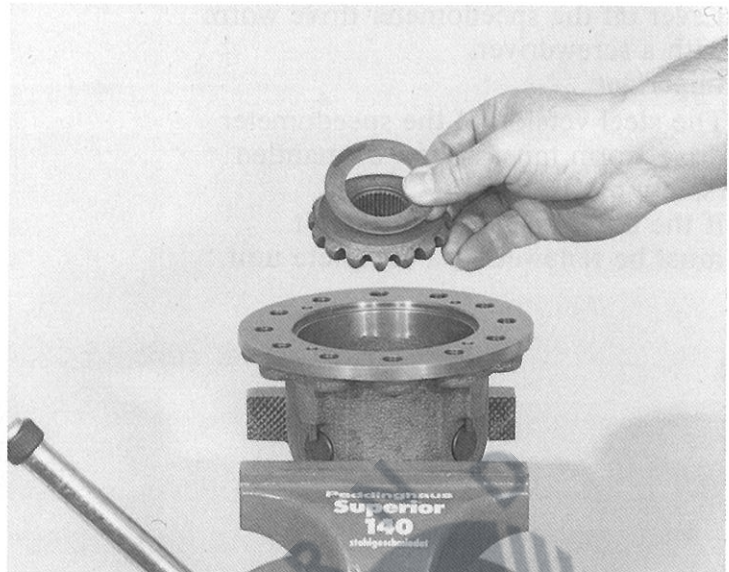

Force two of the dowel pins down slightly and inspect the two short pins, the long pin and the bevel gears for wear in the form of score marks.

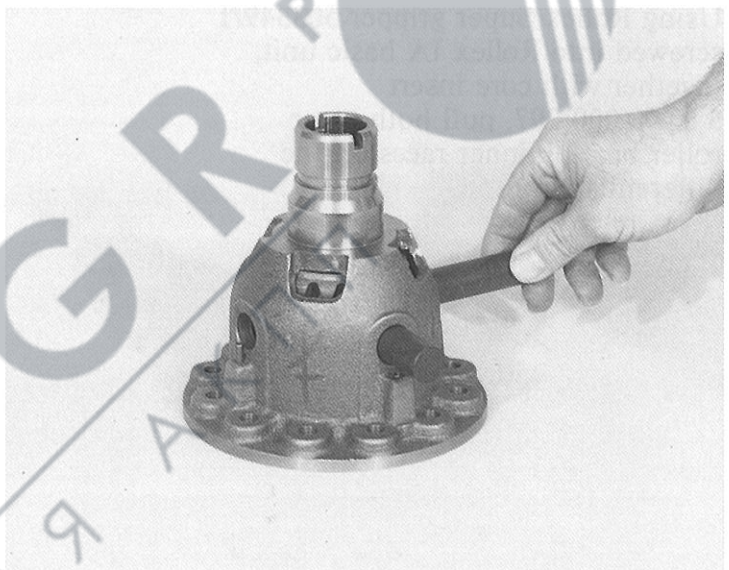

This picture shows the differential after dismantling.

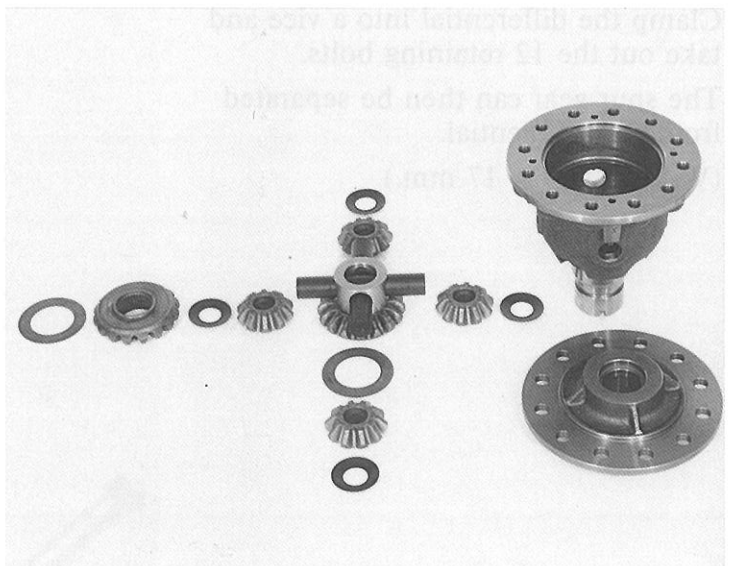

## 2.10 Bell housing and extension

Remove the shaft sealing ring from the bell housing with a suitable drift.

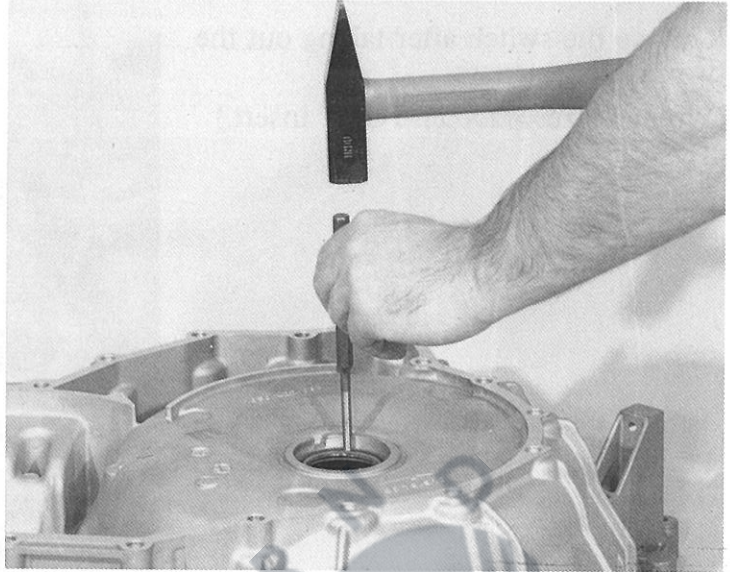

90039

Force out the taper roller bearing outer race with a suitable drift.  
Take the screw plug out of the bell housing.  
(Wrench size = 8 mm Allen key.)

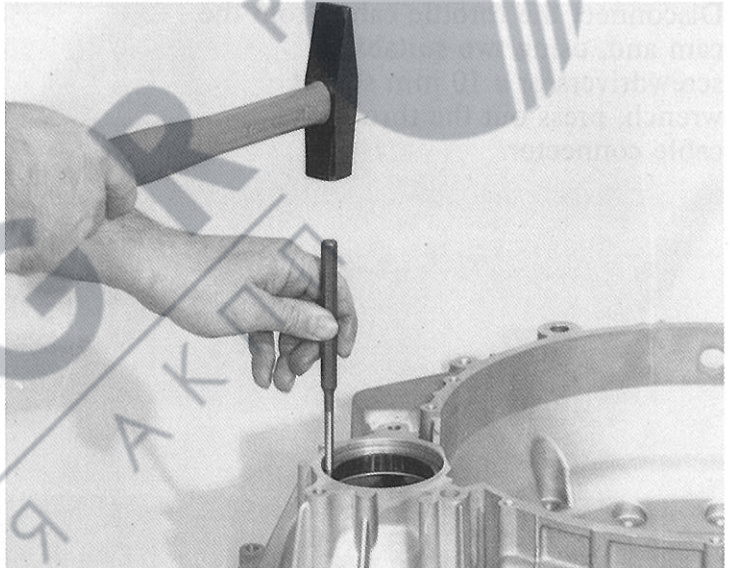

90040

Remove the shaft sealing ring and the O-ring from the extension.

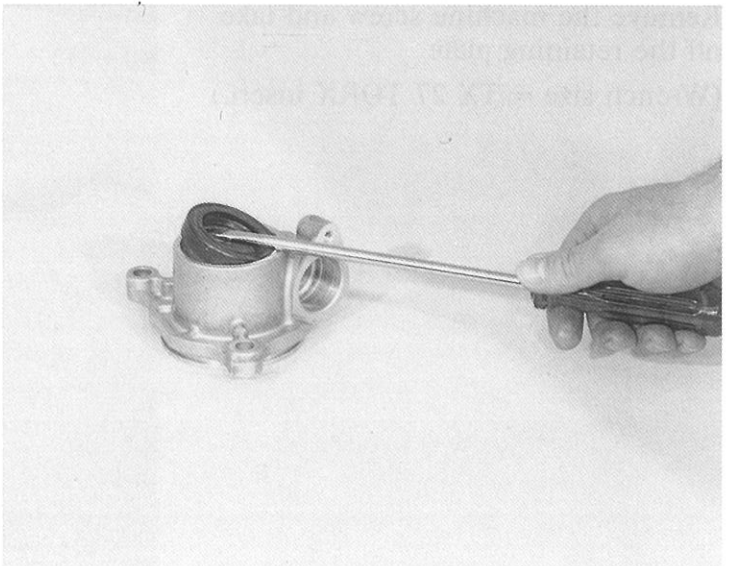



## 2.11 Housing with shift and parking pawl

90041

Remove the switch after taking out the two machine screws.

(Wrench size = TX 27 TORX insert.)

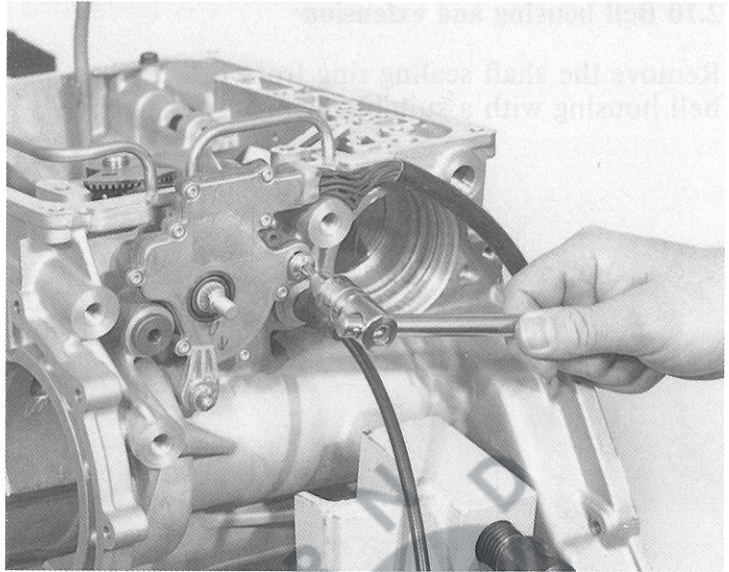

Disconnect the throttle cable from the cam and, using two suitable screwdrivers or a 10 mm socket wrench, press out the throttle cable connector.

90042

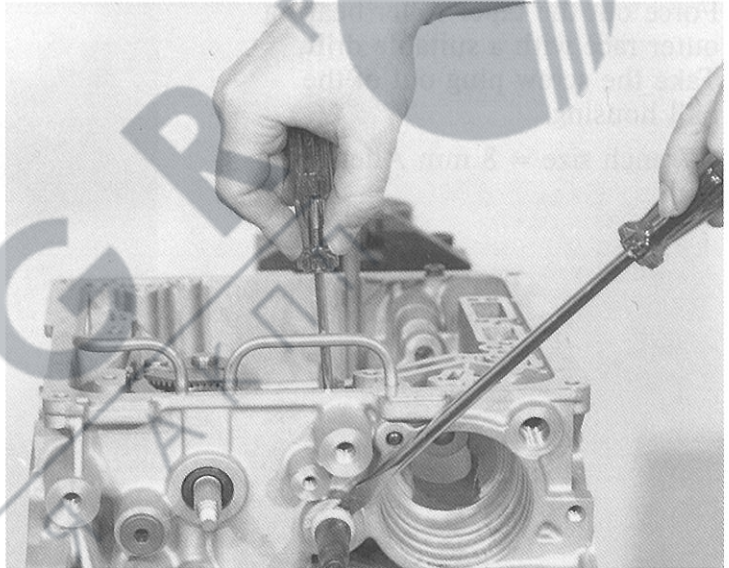

Remove the machine screw and take off the retaining plate.

(Wrench size = TX 27 TORX insert.)

85176

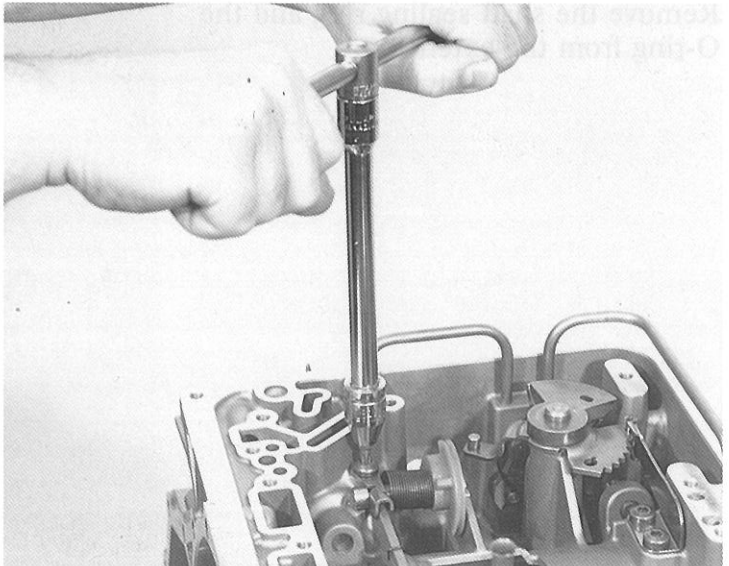

The throttle cam shaft with torsion spring and the throttle cam can now be removed.

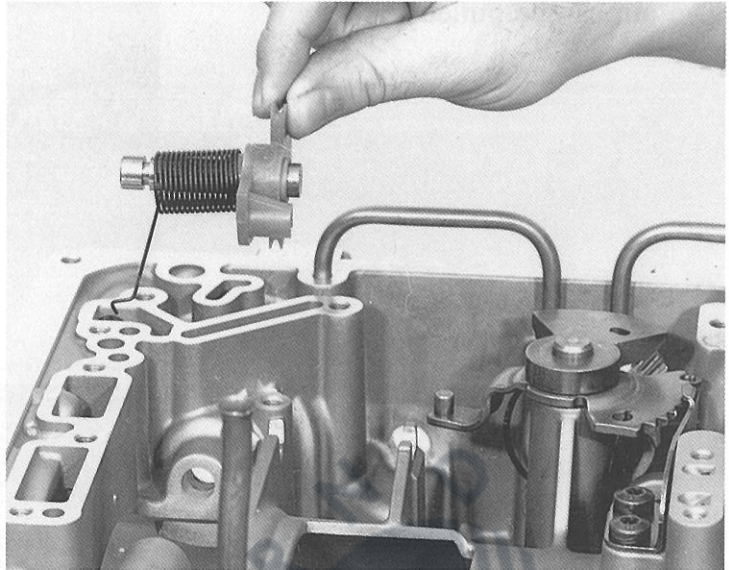

Take out the two machine screws and remove the detent spring.  
(Wrench size = TX 27 TORX insert.)  
Pull out the small locking pin.

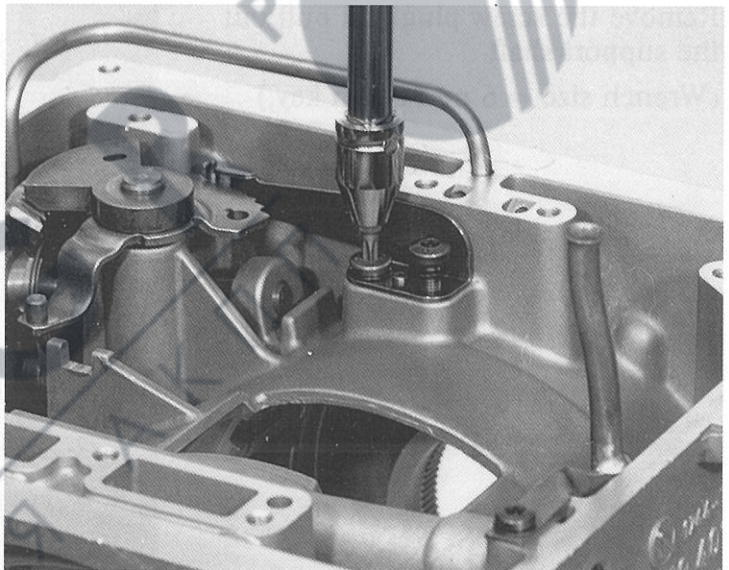

Detach the complete detent disc from the pin.

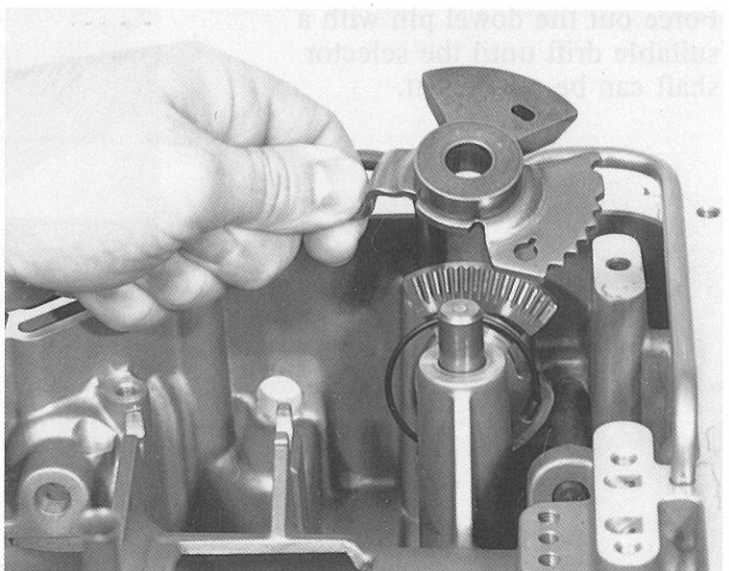



The pin can be pulled out.

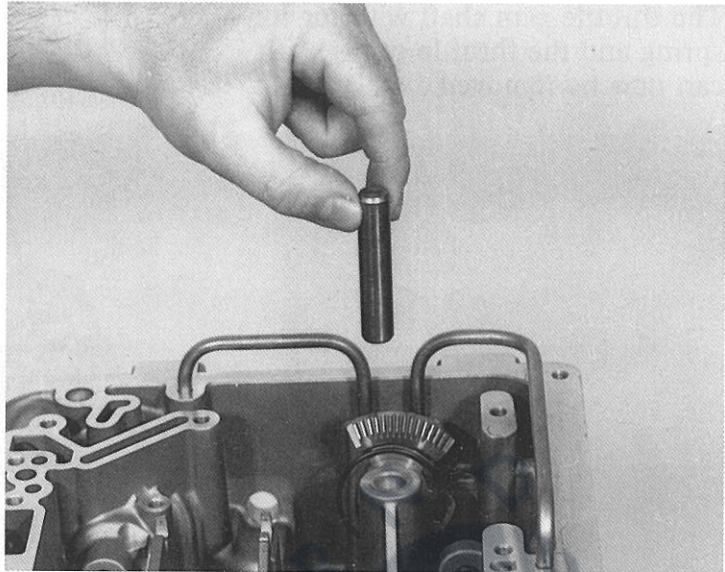

Remove the screw plug and pull out the support shaft.

(Wrench size = 6 mm Allen key.)

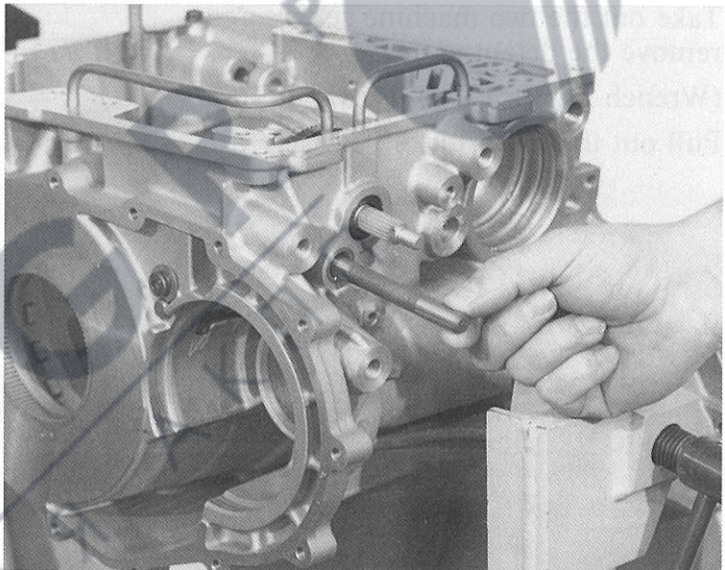

Force out the dowel pin with a suitable drift until the selector shaft can be pulled out.

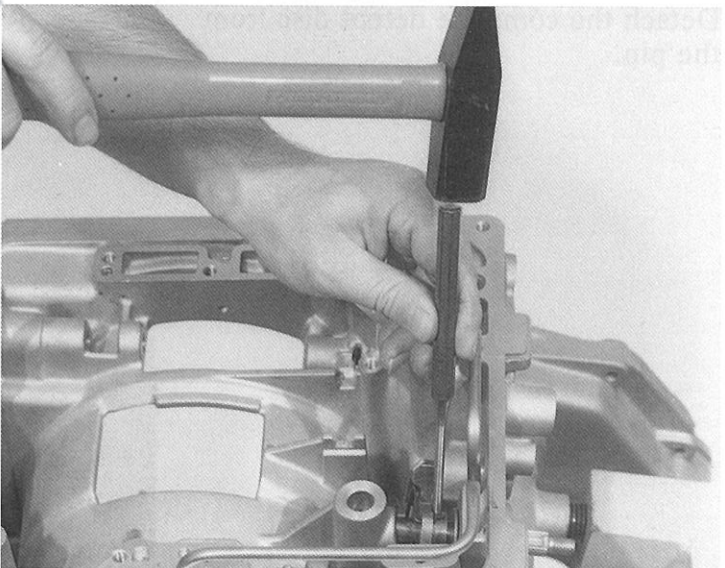



Press the pawl down slightly and take out the segment with locking cam and shim washer.

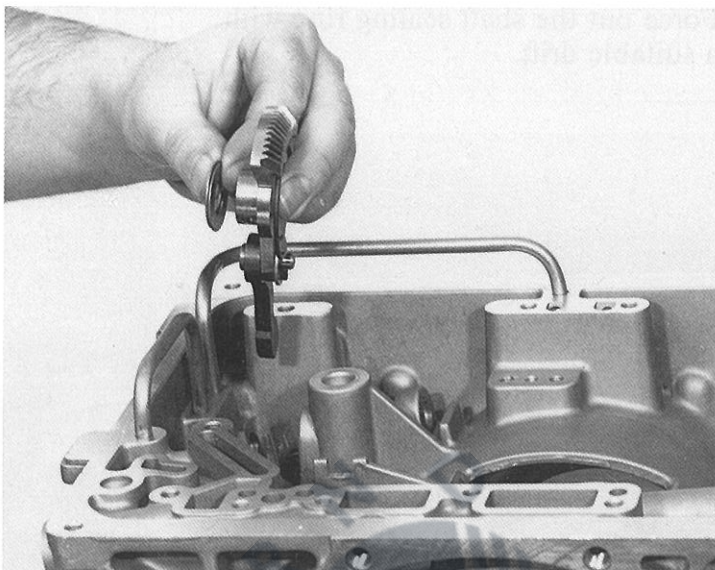

The complete unit can be dismantled by disconnecting the spring clip from the segment and pulling it out of the pin.

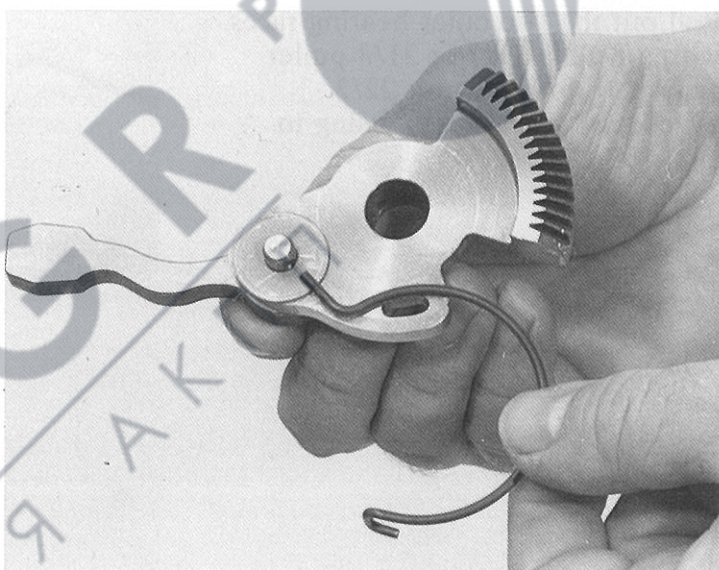

Take out the machine screws, pull the pin out by means of the ring groove and take off the pawl with the torsion spring.

(Wrench size = TX 27 TORX insert.)

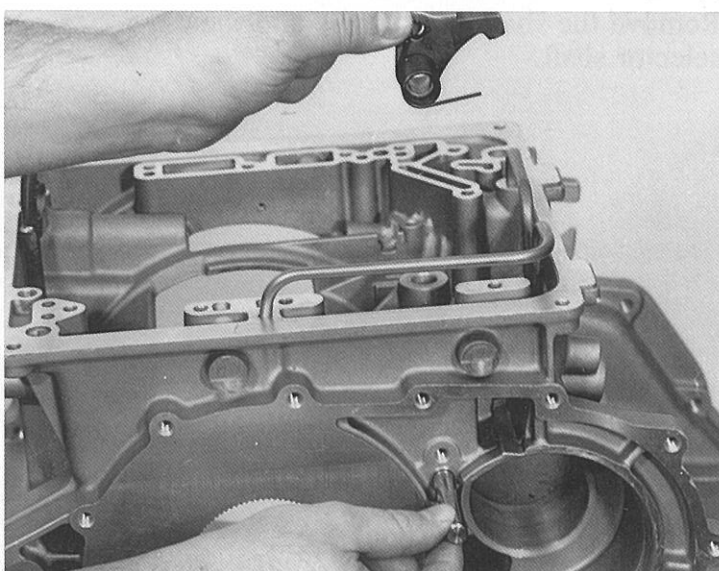



Force out the shaft sealing ring with a suitable drift.



Pull out the two outer bearing races with a Kukko 21/7 or 21/8 puller screwed into basic unit 22/2. If necessary, heat the housing to app. 70°C.

85186

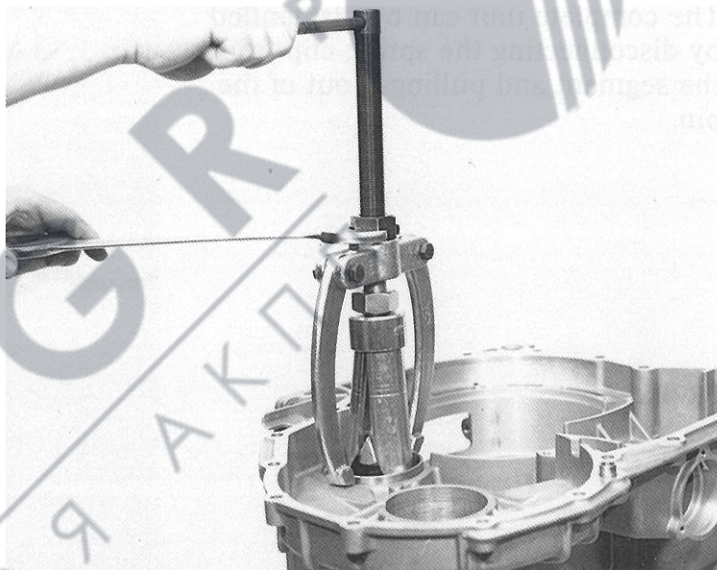

Remove the shaft sealing ring and the selector shaft.

90046

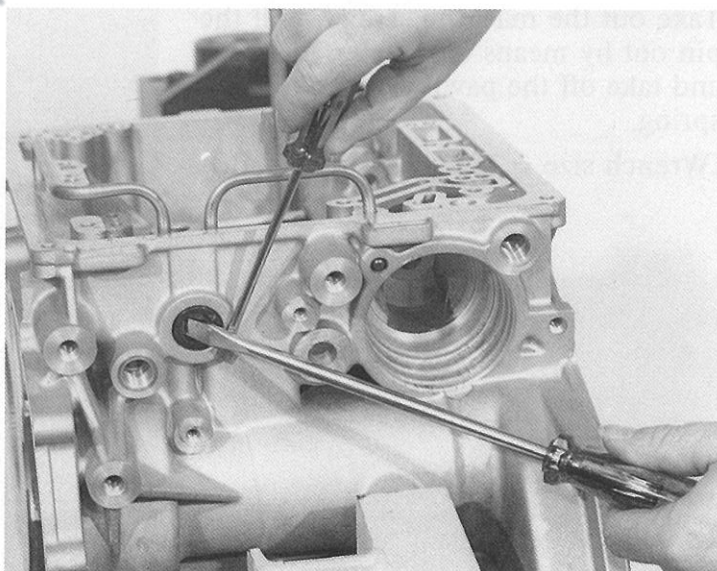

Take out the dipstick tube after removing the retaining screw.  
(Wrench size = TX 27 TORX insert.)

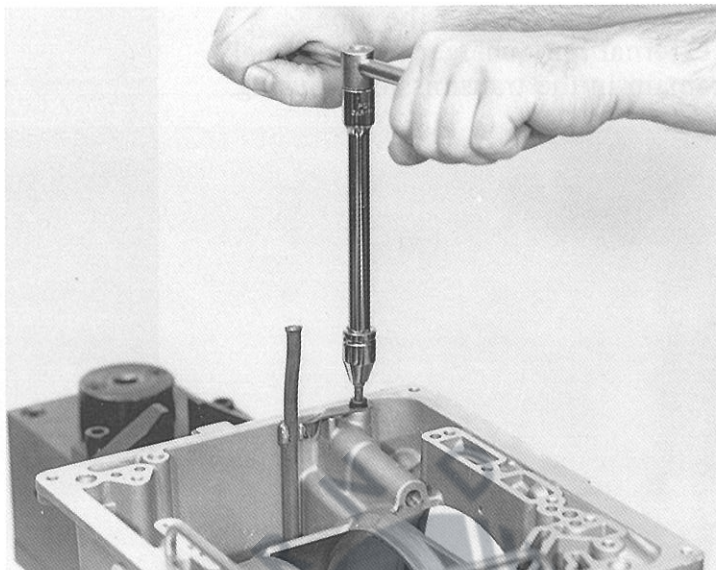

90047

Pull out the oil pipe with suitable pliers.

**Warning:**  
Do not damage the sealing surface.

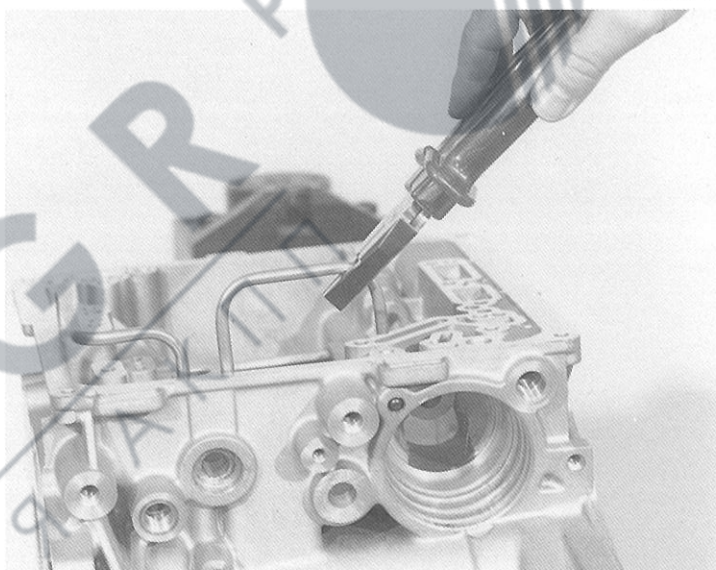

90048

When cleaning the transmission housing it is advisable to take out all screw plugs.  
(Wrench size = 5 mm Allen key.)

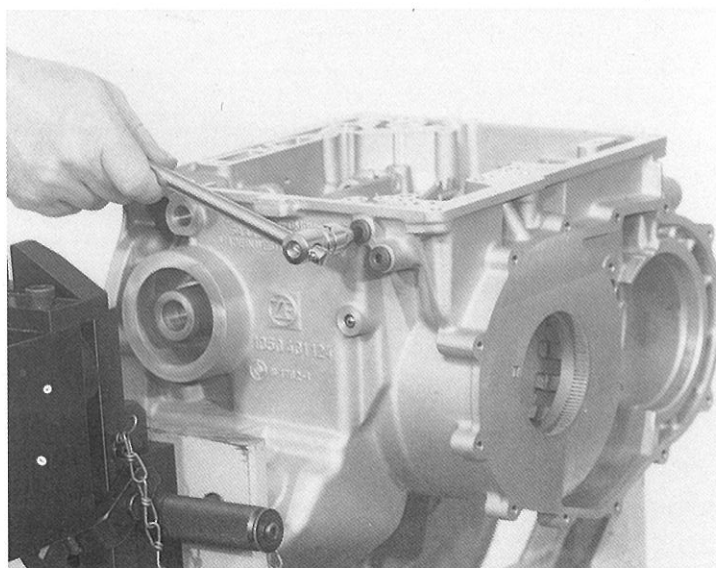



The locating pin and the pipe (external turbocharger feed) normally remain in the transmission housing.

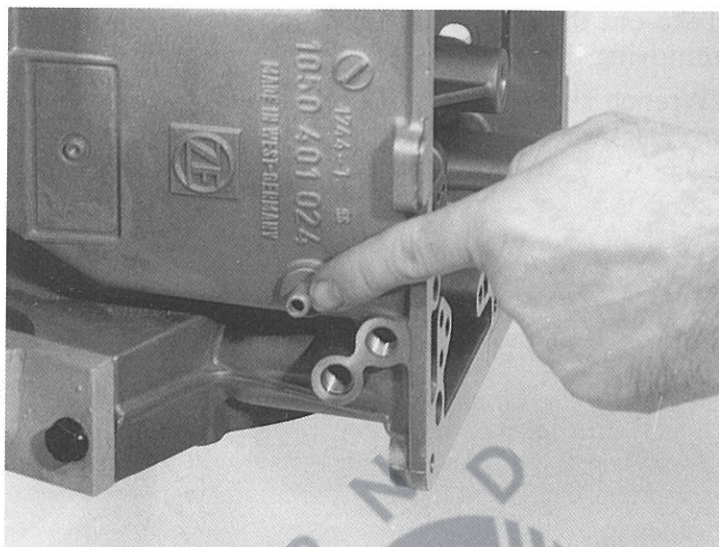

AVTGR  
ВСЕ ДЛЯ АКПП  
P R M D

### 3. Assembling

#### 3.1 Transmission housing with shift and parking pawl

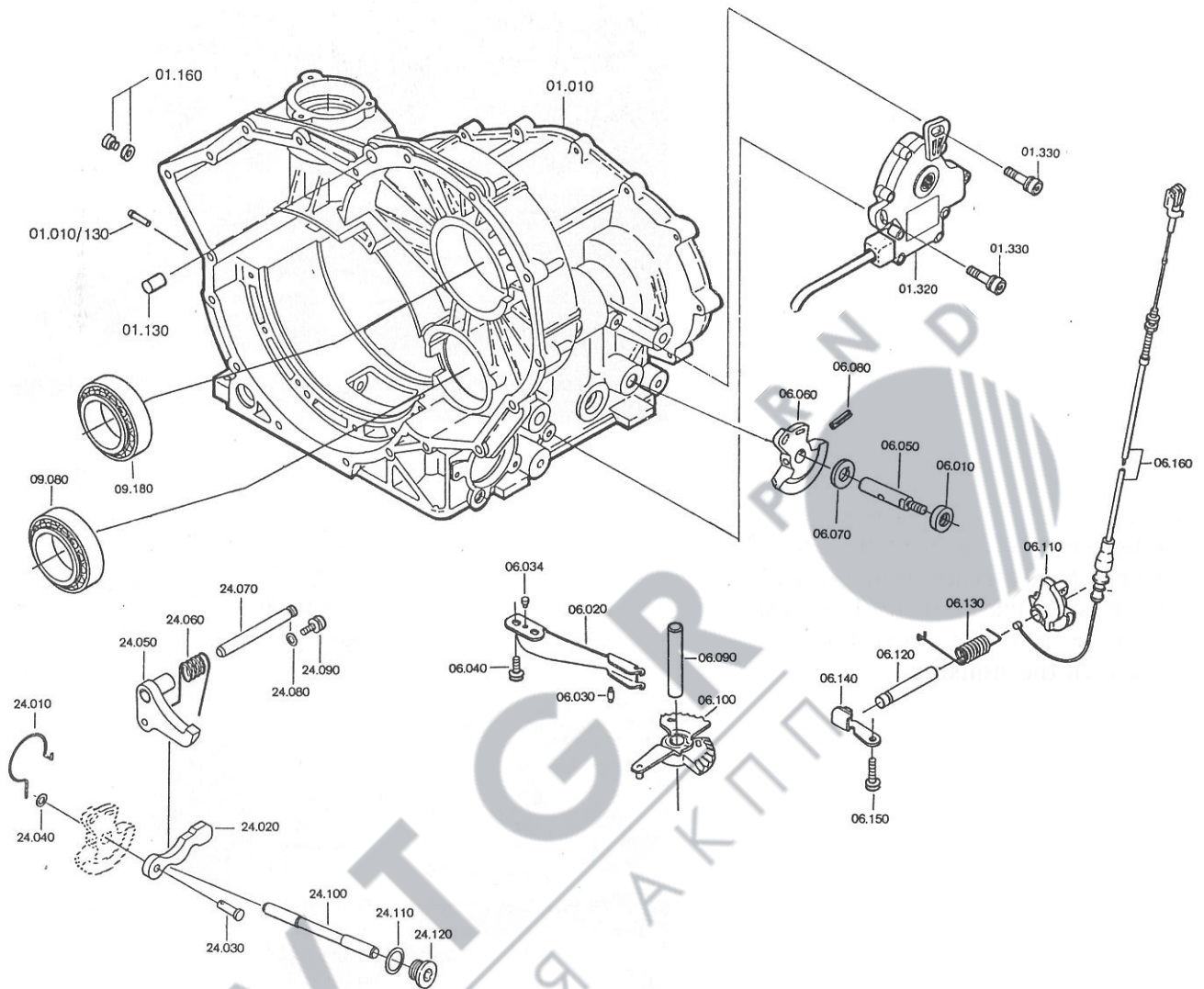

85 192

On the turbocharged version, first drive pipe 01.010/130 (turbocharger pressure feed) carefully into transmission housing 01.010 with a plastic-faced hammer as far as it will go.

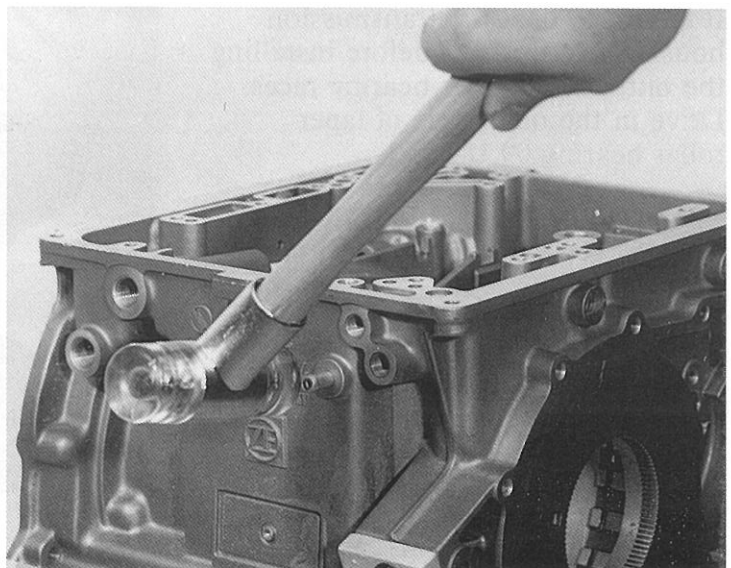



Insert screw plugs 01.160 with new sealing rings.

(Wrench size = 5 mm Allen key.)

(Tightening torque: 15 Nm.)

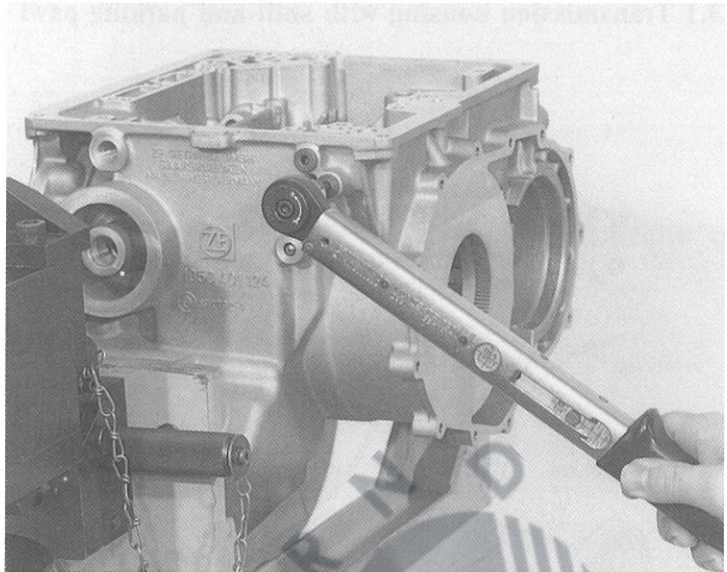

Turn the transmission through 90 degrees and drive bushing 01.130 into the transmission housing with a plastic-faced hammer until at least 10 mm still project above the surface of the housing.

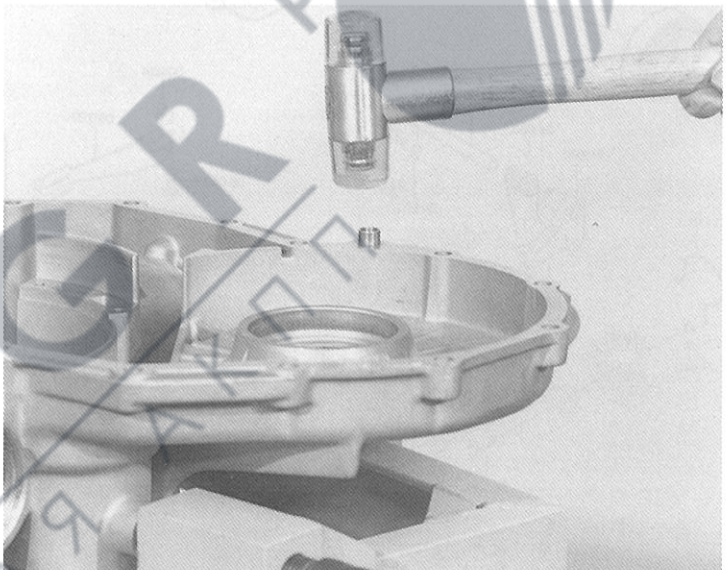

It is best to heat the transmission housing to app. 70°C before installing the outer taper roller bearing races. Drive in the outer race of taper roller bearing 09.180 fully.

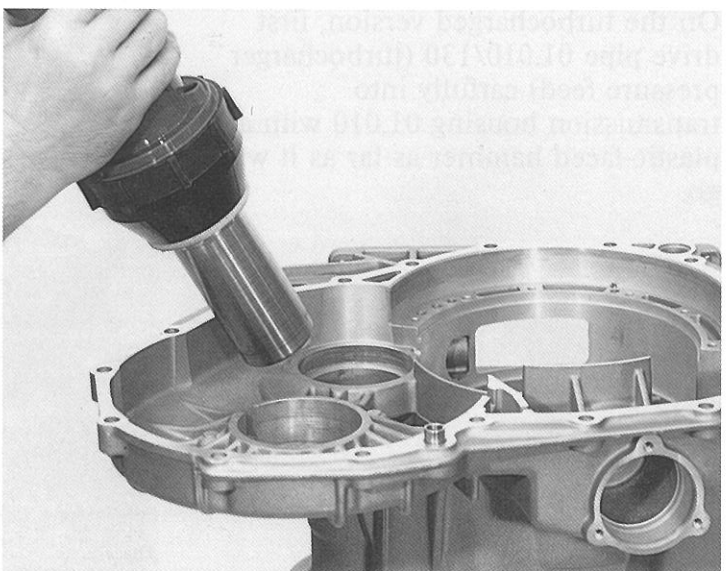

Drive the outer race of taper roller bearing 09.080 (side shaft) in fully.

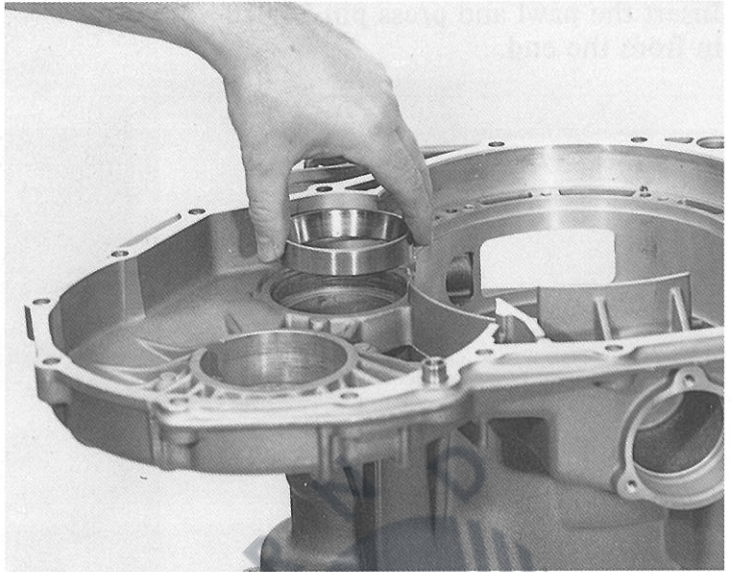

Coat the new shaft sealing ring 06.010 with Vaseline (petroleum jelly) and drive it in with assembly arbor 5 X 46 000 187.

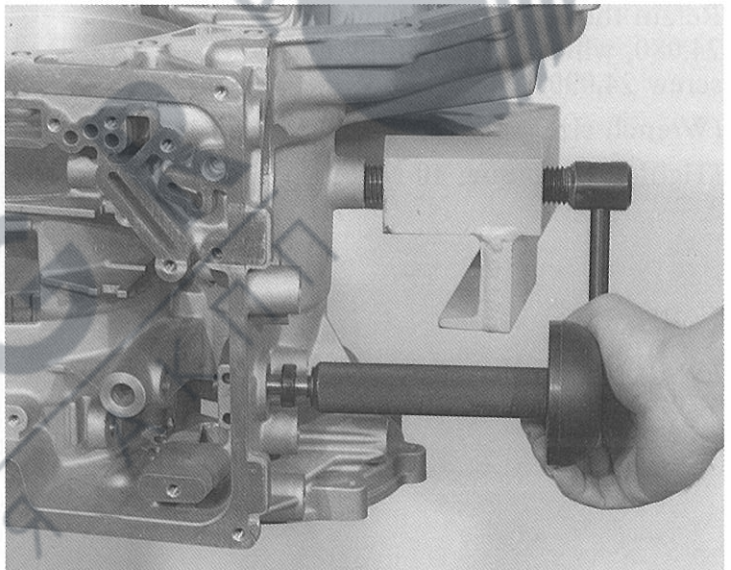

Insert torsion spring 24.060 in the pawl 24.050 as shown in this picture.

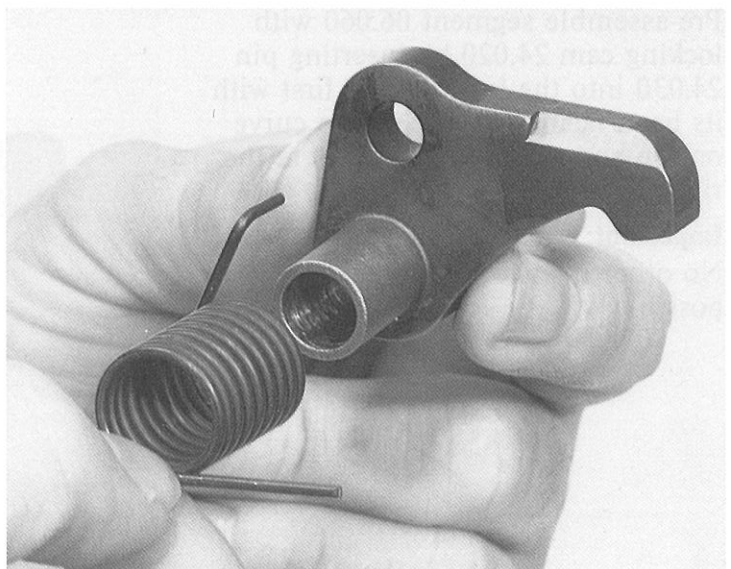



Insert the pawl and press pin 24.070 in from the end.

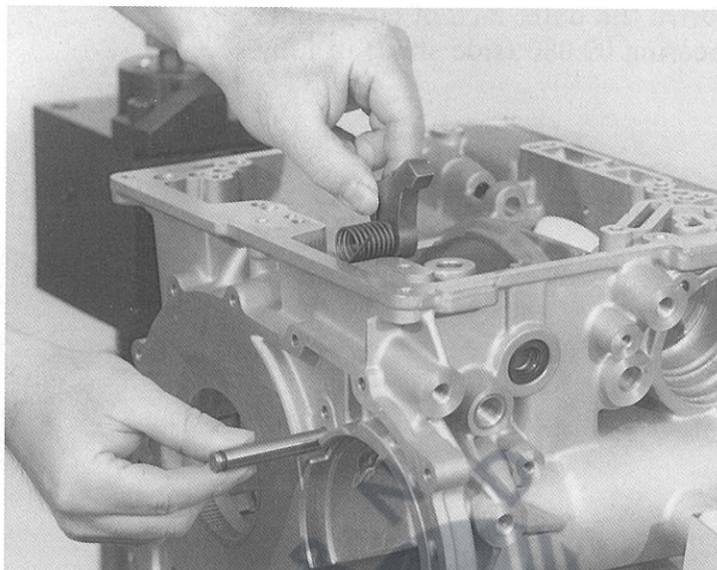

Retain the pin in the groove with disc 24.080, which is secured by machine screw 24.090.

(Wrench size = TX 27 TORX insert.)

(Tightening torque: 10 Nm.)

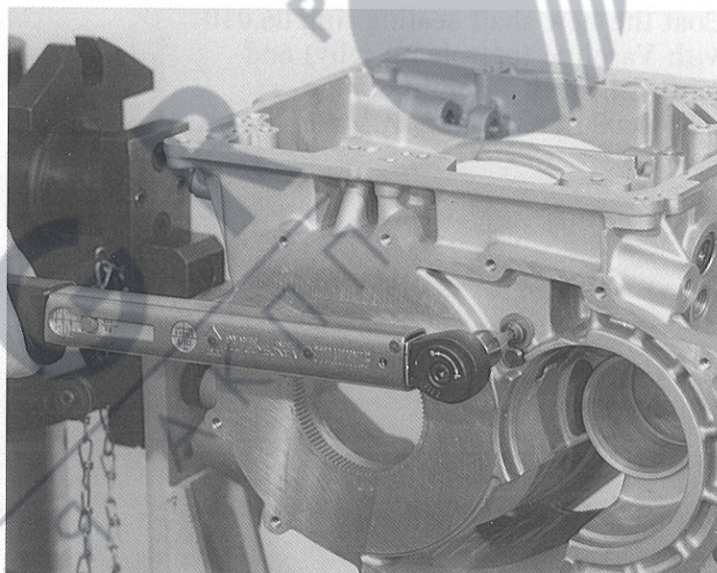

Pre-assemble segment 06.060 with locking cam 24.020 by inserting pin 24.030 into the locking cam first with its head facing left, the centre curve on top and the eye of the cam at the right.

**Important:**

No other installed position is possible.

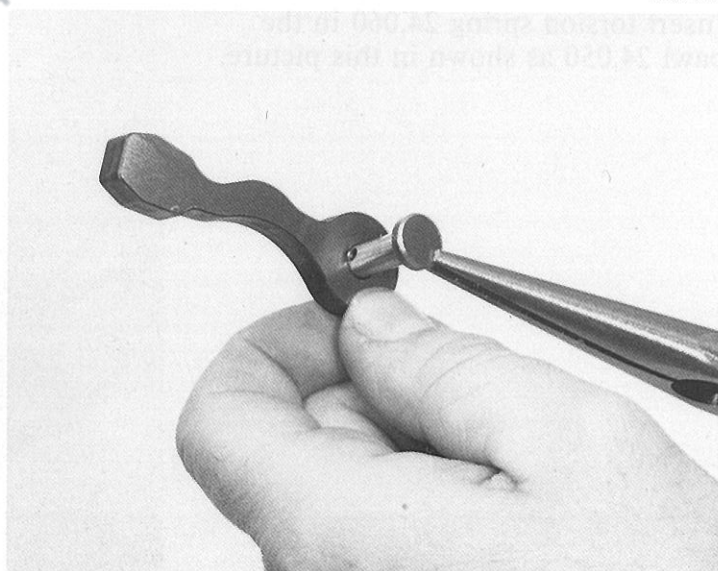



85 204

Insert the pin together with the locking cam in the segment, turn the complete assembly over and place washer 24.040 over the pin.



85 205

Next, insert spring clip 24.010 through the pin and connect it to the segment.

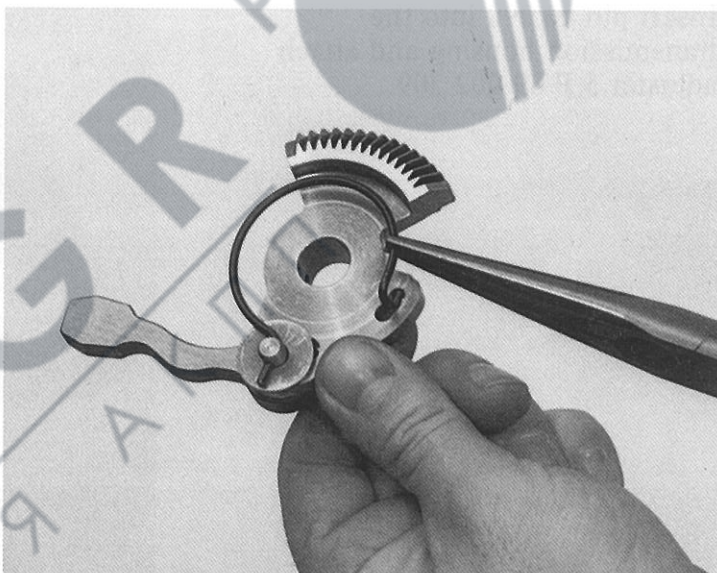

90 055

Install the complete unit by pressing down the pawl and pushing support shaft 24.100 fully in.

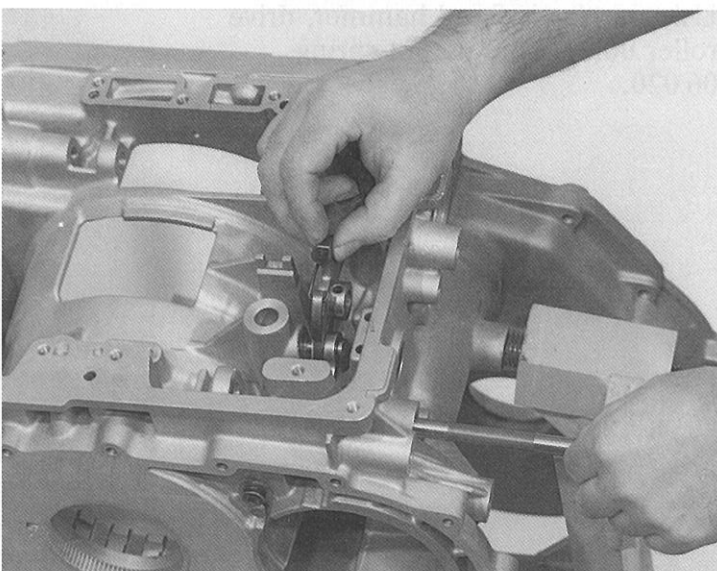



90056

Insert screw plug 24.120 with a new sealing ring 24.110.

(Wrench size = 6 mm Allen key.)

(Tightening torque: 32 Nm.)

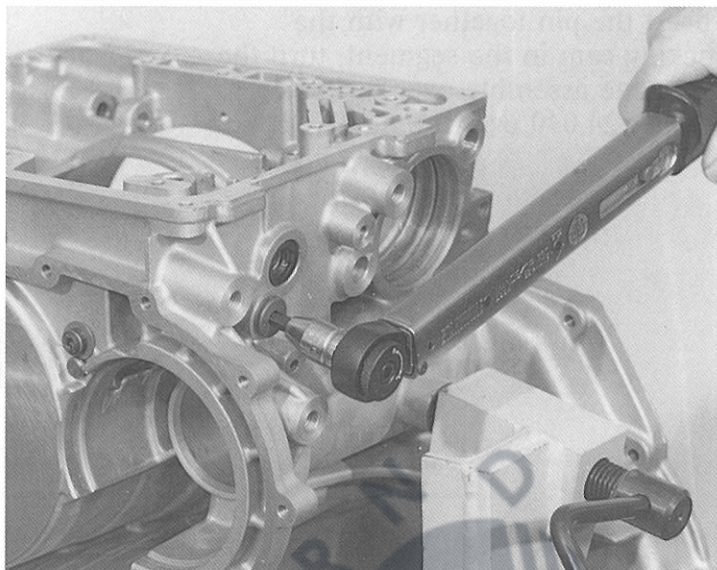

85208

Insert pin 06.090 into the transmission housing and attach adjuster 5 P 89 002 209.

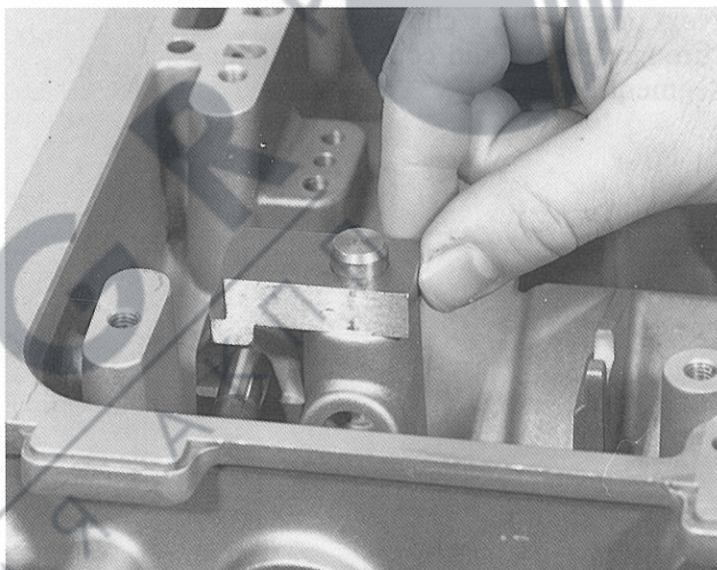

85209

Using a plastic-faced hammer, drive roller 06.030 into detent spring 06.020.





To locate pin 06.034 in the housing, press it in and attach the detent spring.

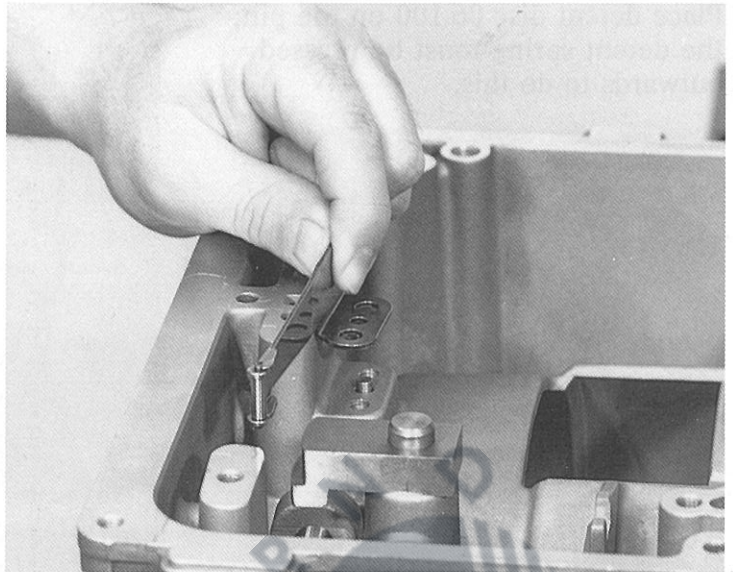

Press the detent spring against the adjuster and secure it in this position with two machine screws 06.040.  
(Wrench size = TX 27 TORX insert.)  
(Tightening torque: 10 Nm.)

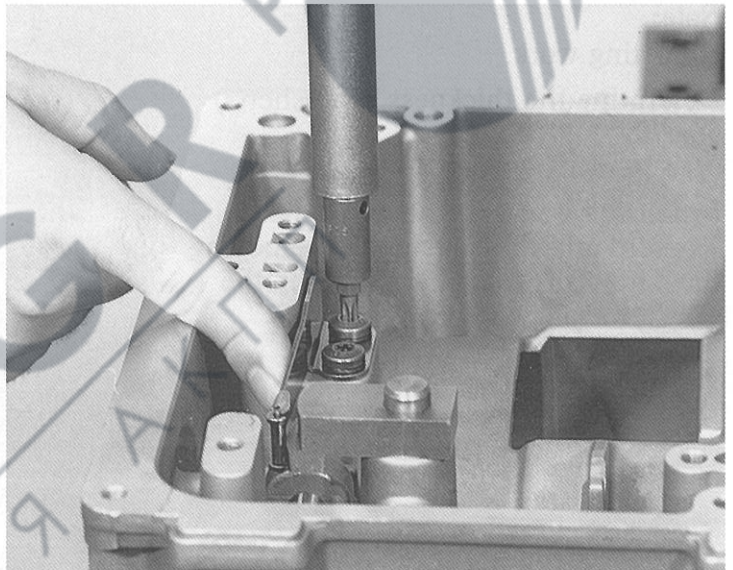

Press selector shaft 06.050 into the segment.

**Warning:**  
Avoid damage to the thread.

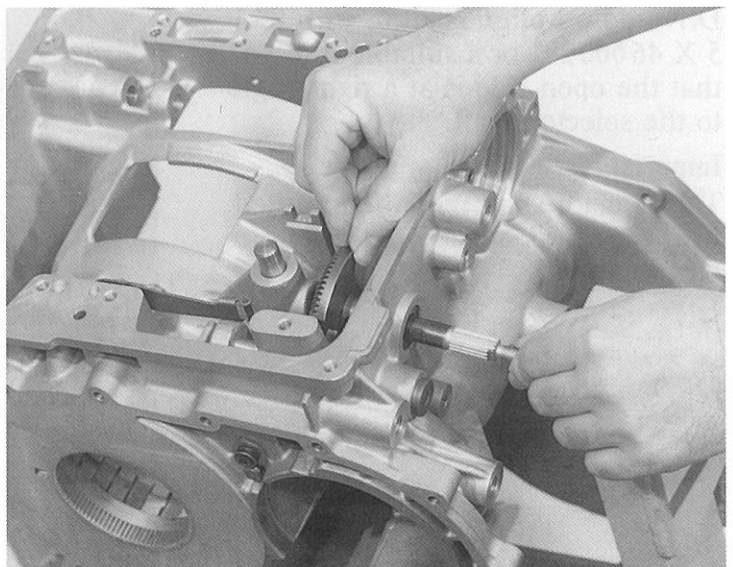



Place detent disc 06.100 on the pin; the detent spring must be pressed outwards to do this.

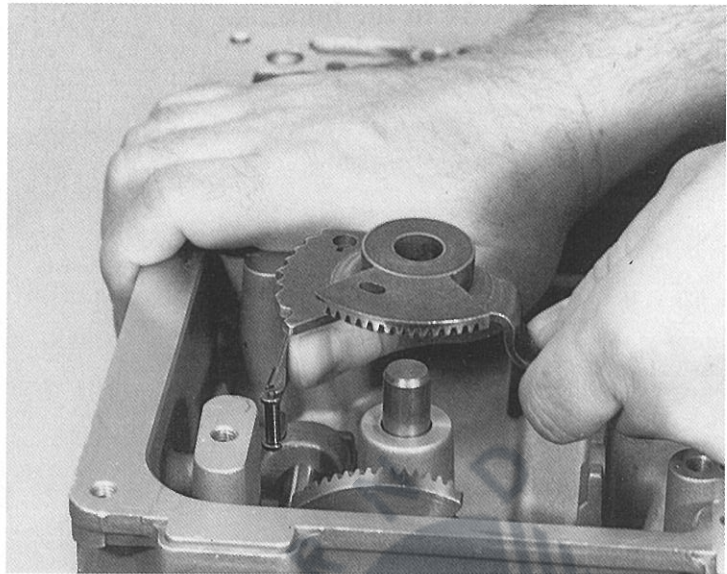

**Note:**

Adjusting work.

Determine the thickness of washer(s) 06.070.

(See Item 1.4.1, Page 5/1.)

Install the washer(s) between the segment and the housing, by removing the detent disc again and pulling the selector shaft out sufficiently.

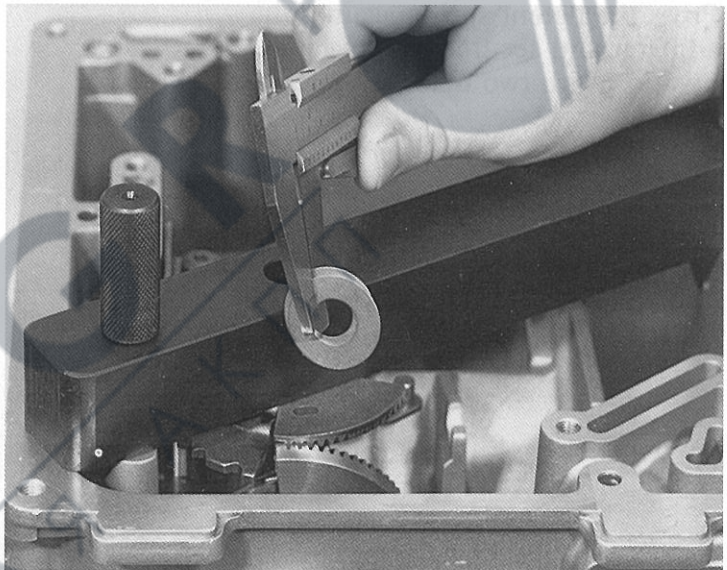

Drive dowel pin 06.080 in with tool 5 X 46000291 or a suitable drift so that the open side is at a right angle to the selector shaft.

**Important:**

The selector shaft must be installed with the flattened side of the splines facing down.

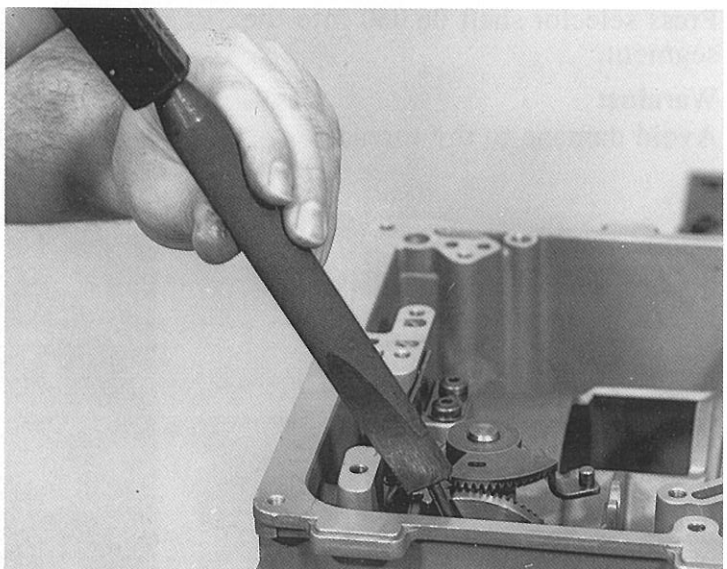



Set detent disc to position N.

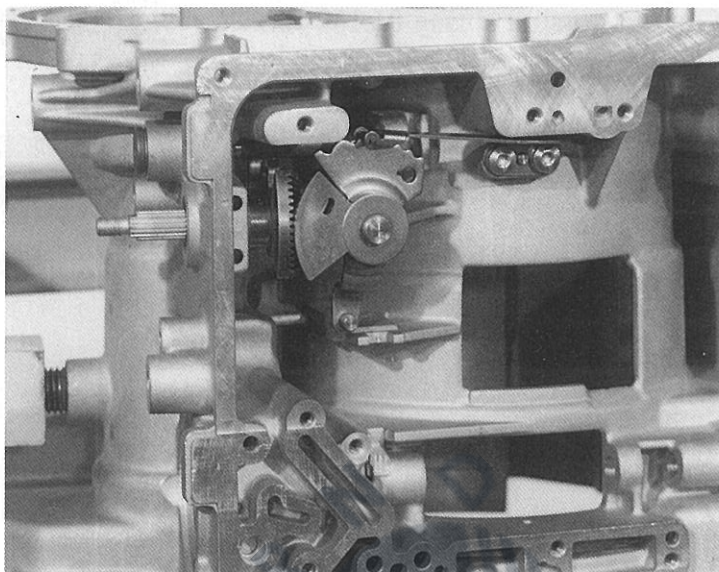

Mount switch 01.320 on the selector shaft and attach it with two screws 01.330, but do not tighten the screws fully yet.

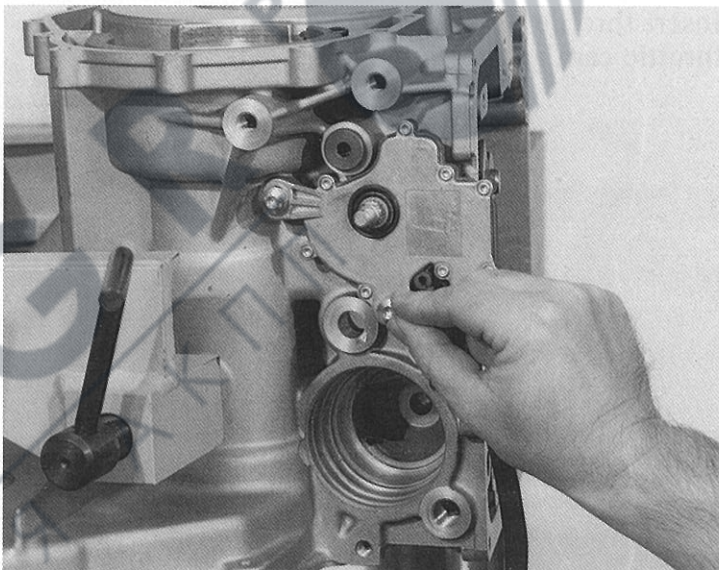

Mount lever 0501 311 626 on the splines of the selector shaft.

**Important:**

If there is play at the splines, always renew the lever.

Turn the switch sufficiently for the locating pin to be pressed into the hole.

Tighten the two screws to a torque of 10 Nm, then seal them with red lacquer.

(Wrench size = TX 27 TORX insert.)

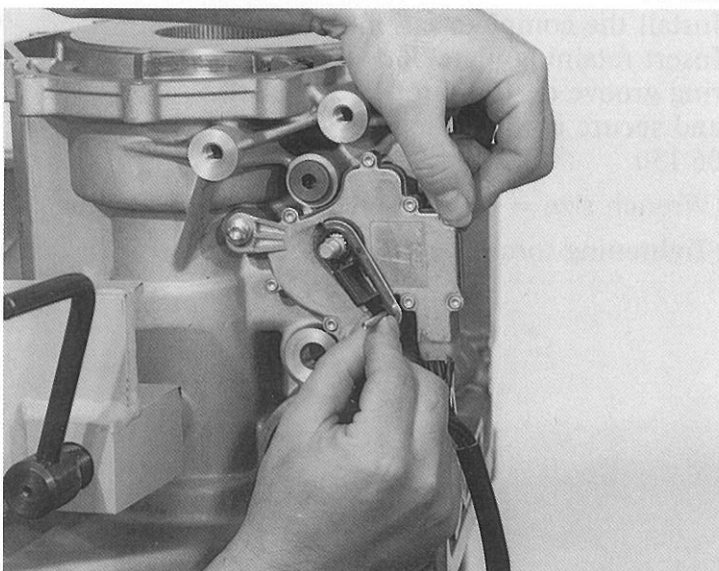



Connect torsion spring 06.130 to throttle cam 06.110 as illustrated.

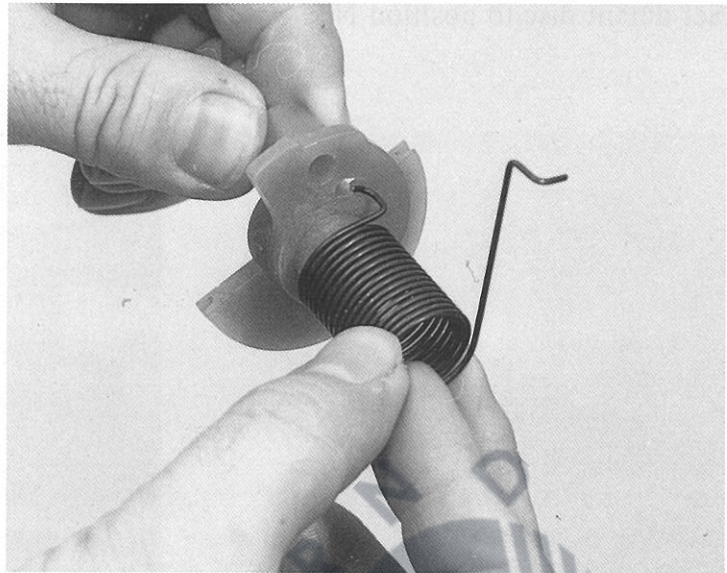

Insert throttle cam shaft 06.120 into throttle cam and torsion spring.

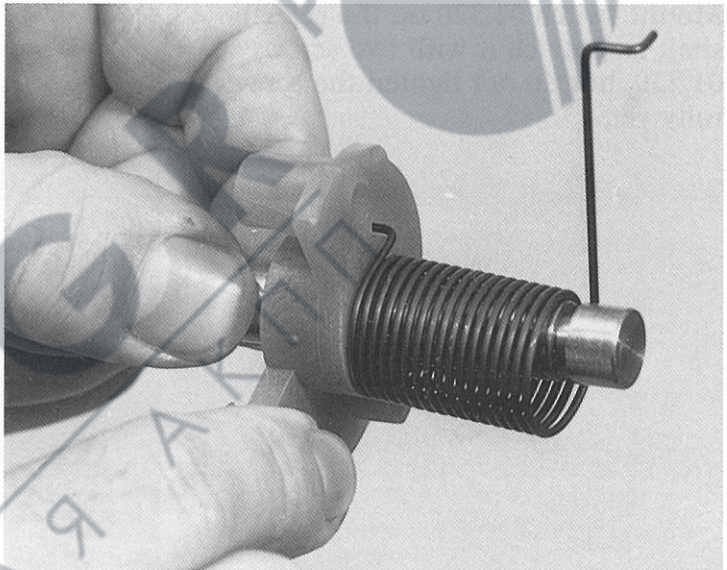

Install the complete assembly.  
Insert retaining plate 06.140 into the ring groove on the throttle cam shaft and secure it with machine screw 06.150.

(Wrench size = TX 27 TORX insert.)

(Tightening torque = 10 Nm.)

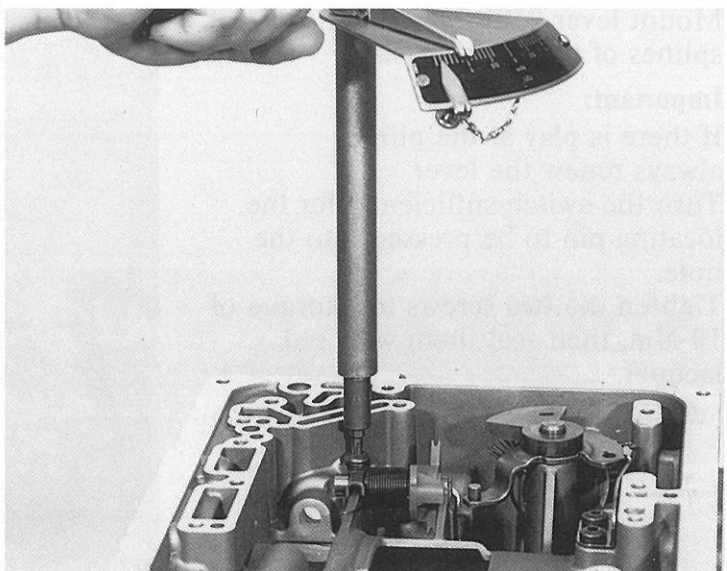

Press the new throttle cable 06.160 into the transmission housing.

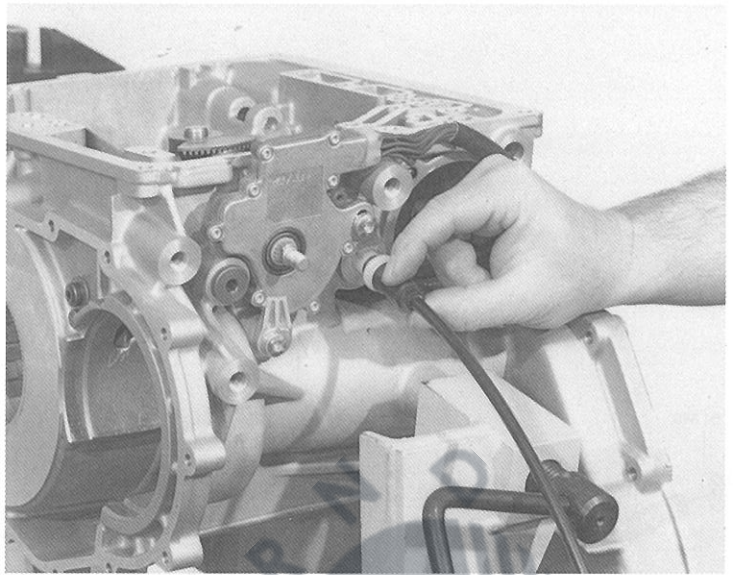

Preload the throttle cam by one turn and connect the cable nipple to the cam.

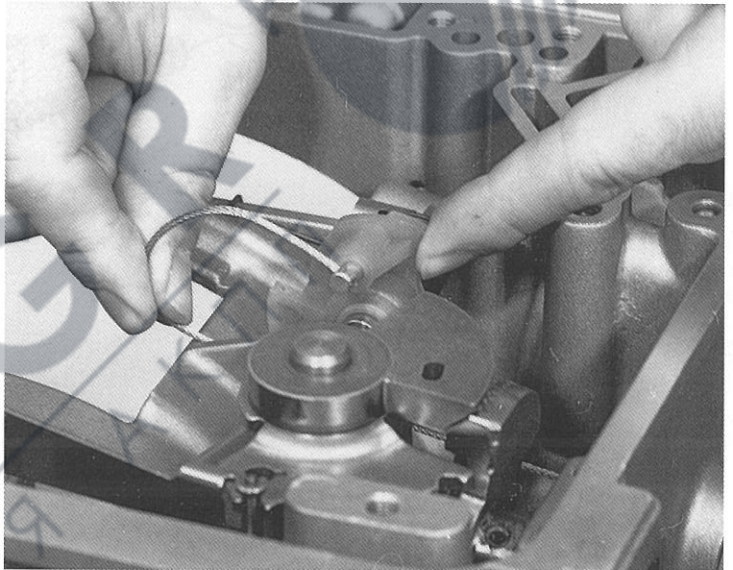

AVT  
BCEAA

For two rows of rings, 31.323 into the  
transmission pin 10 and rest them  
on the rings.



### 3.2 Brake C'

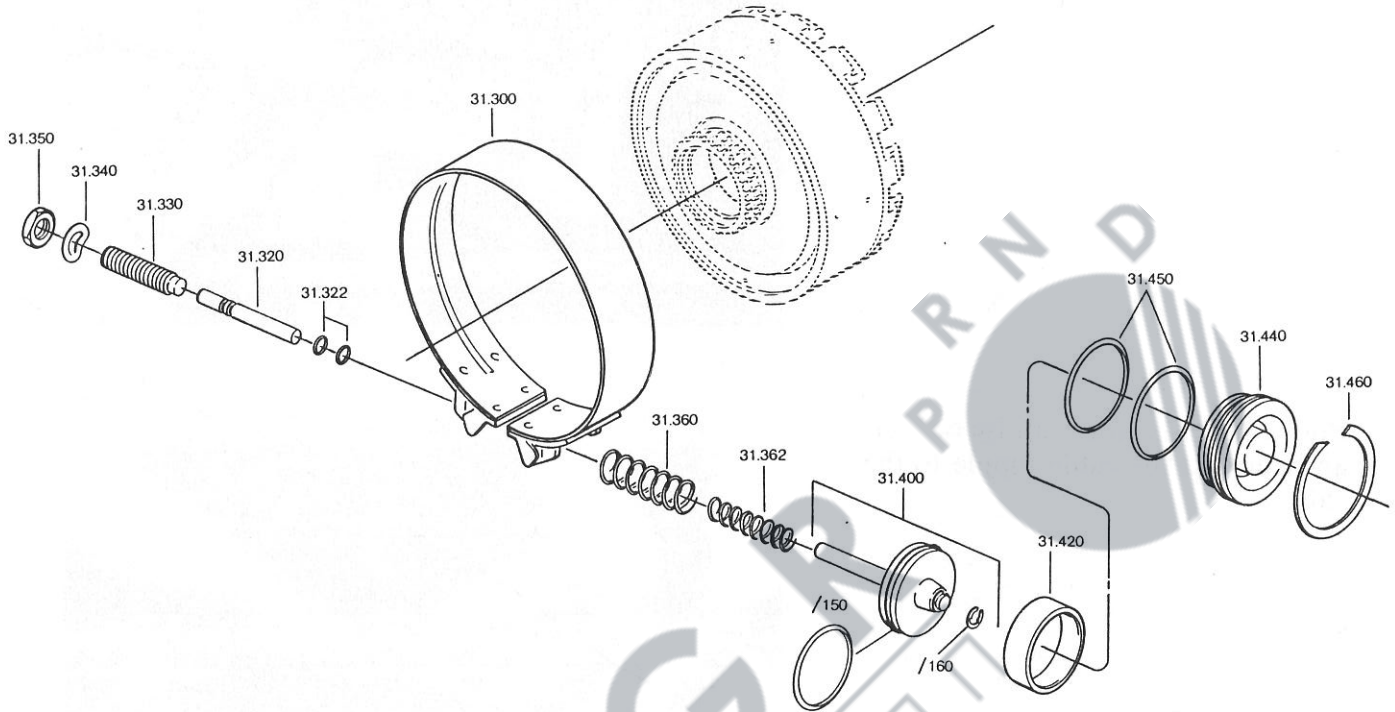

90062

Pull two new O-rings 31.322 into the groove on pin 31.320 and coat them with grease (Vaseline).

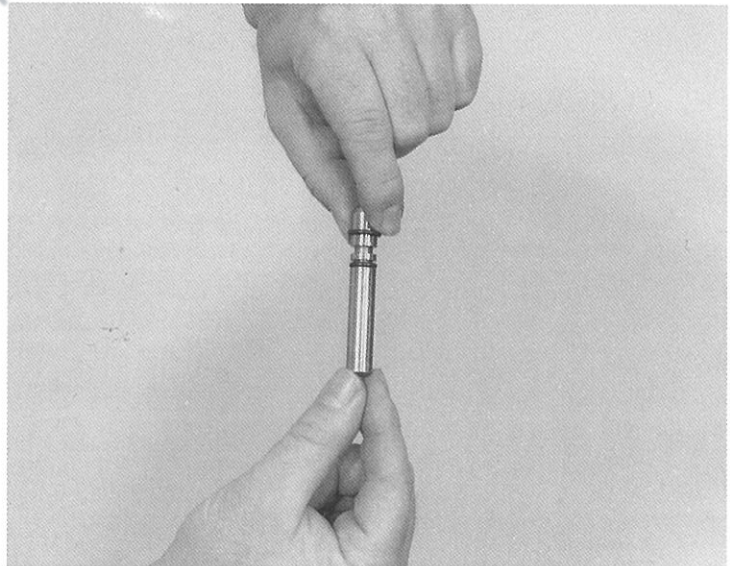

Insert the pin into the housing so that the two O-rings acts as a seal at the outside of the housing.

Pre-assemble adjusting screw 31.330 with spring washer 31.340 and hex nut 31.350, and screw it halfway into the housing.

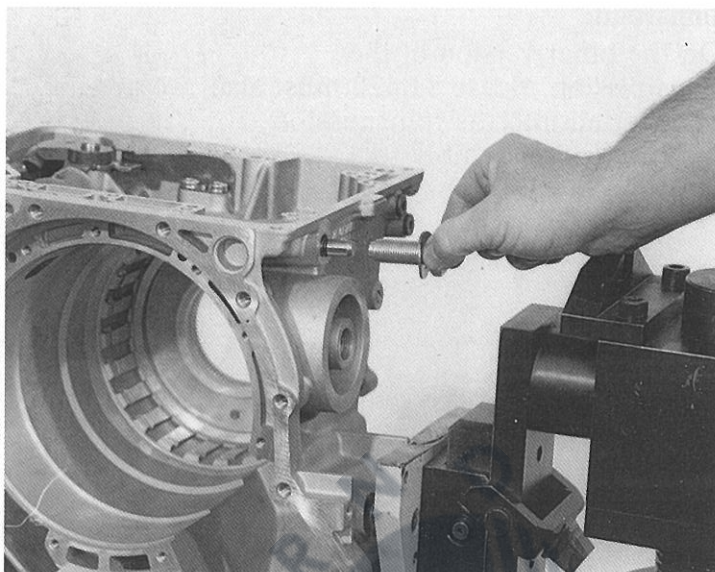

Depending on the version installed, piston C' (31.400) is pre-assembled to different degrees.

If completely dismantled, it should be assembled as shown in the drawing on the right.

If the washers differ in thickness, the thicker one should be installed against the shoulder on the pin.

Always renew O-ring 31.400/150. Renew circlip 31.400/160 only if necessary.

Version 1

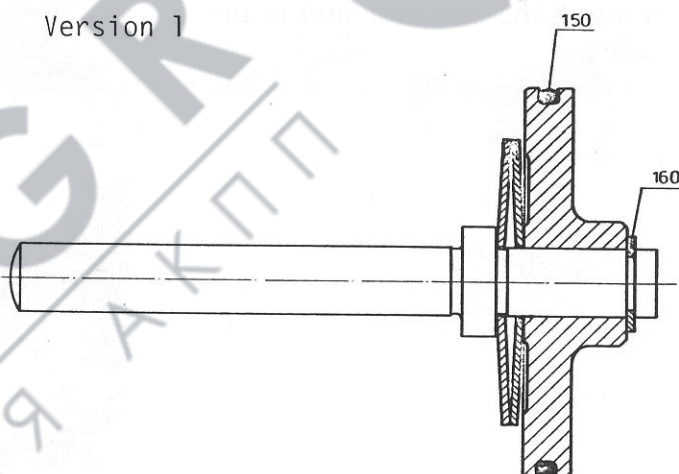

Version 2

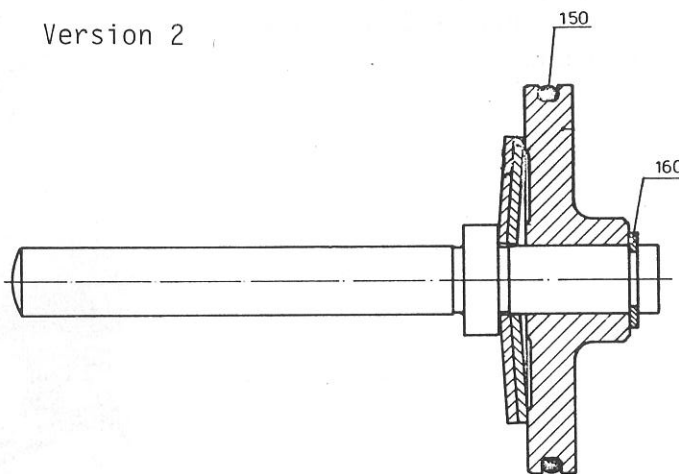



**Important:**

On the other version of the transmission, sleeve 31.420 must also be inserted into the transmission housing with assembly tool 5 X 46 000 267.

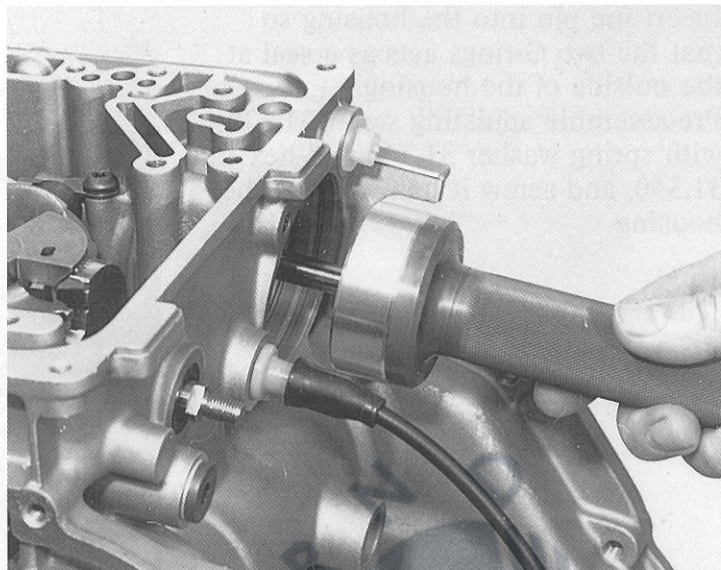

90064

Pass the coil springs 31.360 and 31.362 over the piston rod, coat the O-ring lightly with grease (Vaseline) and install the complete unit in the housing.

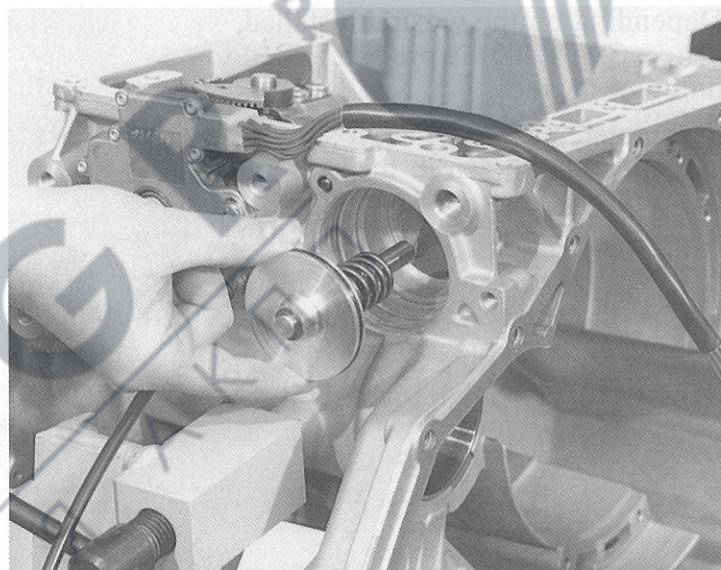

90065

Attach two new O-rings 31.450 to the cover 31.440, coat them lightly with grease (Vaseline) and press into the housing.

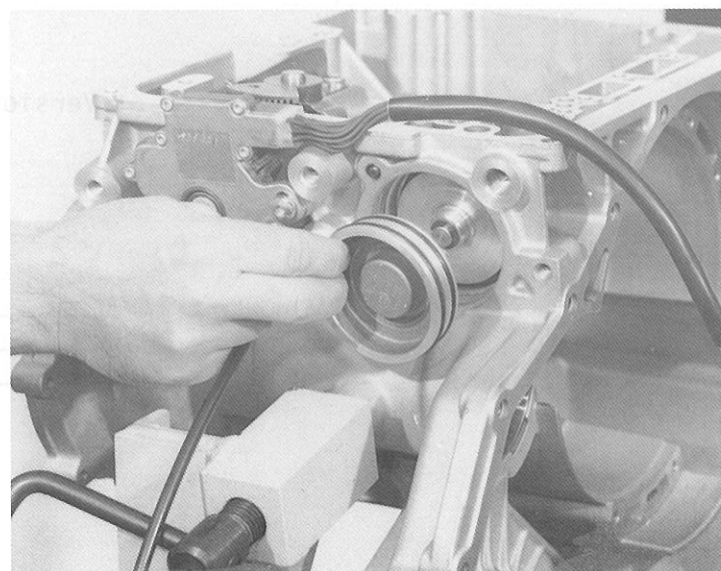

Screw assembly fixture 5 X 46000273 into the oil cooler connecting hole (remove the screw plug) and press the cover down slightly. Insert snap ring 31.460 into the groove.

Remove the assembly fixture and screw the plug back in.

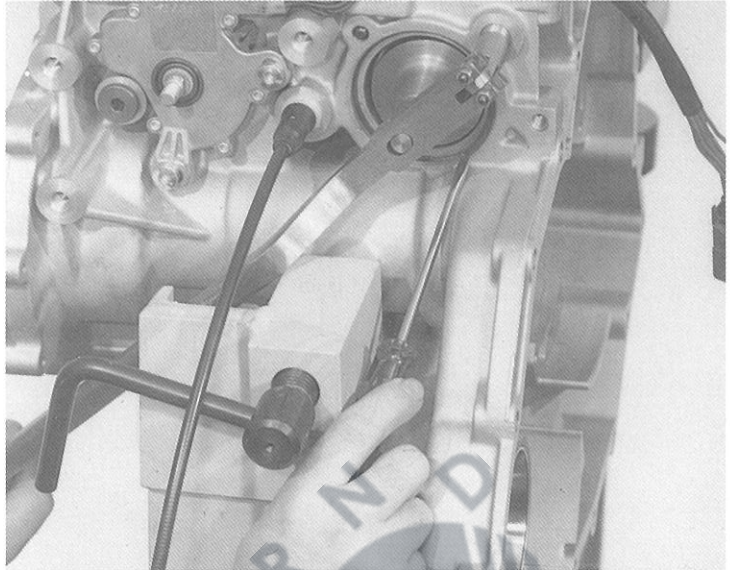

Turn the transmission through 90 degrees.

Press brake band 31.300 together lightly and attach the lugs to the two pins.

Note the step in the transmission housing.

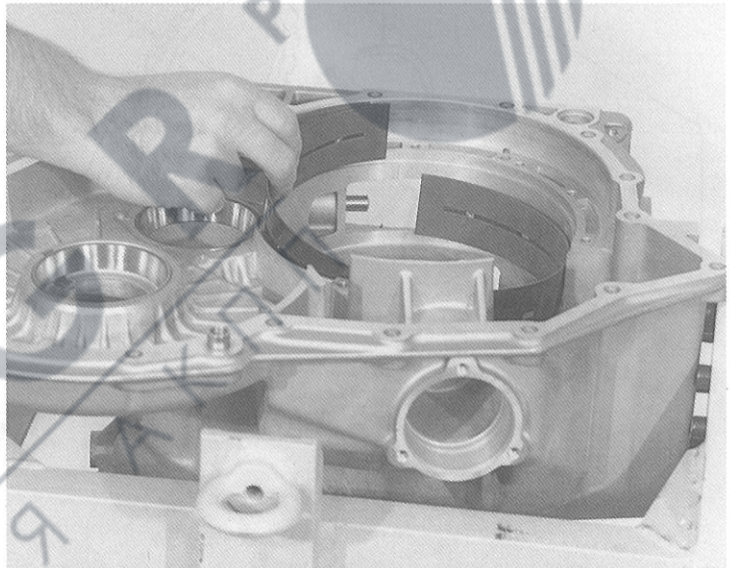



### 3.3 Brake D with 1st gear freewheel

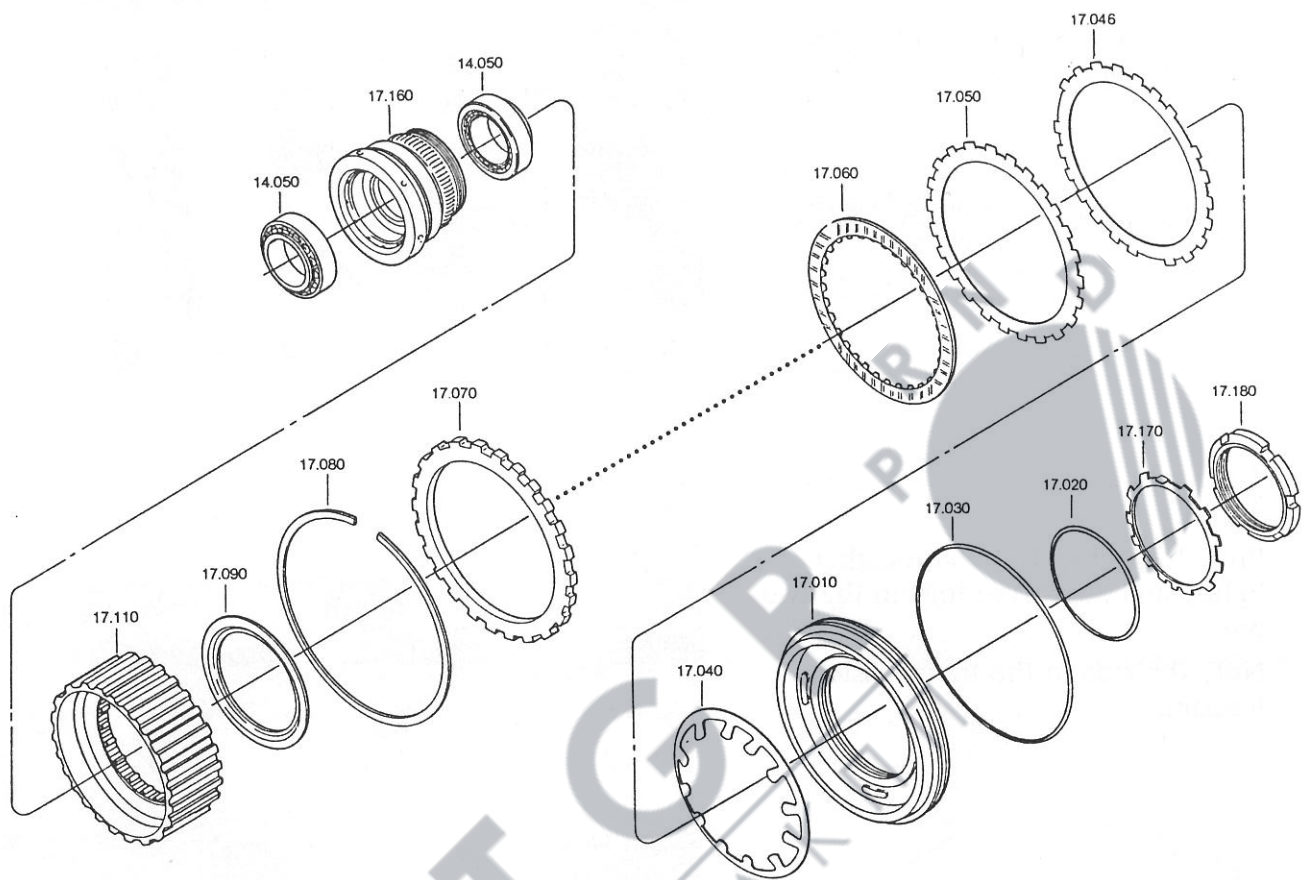

85 231

Pull the two O-rings 17.020 and 17.030 on to piston 17.010, grease them lightly (with Vaseline) and press the piston into the housing with the raised part at the top.

**Warning:**

The piston must make full contact in order to avoid obtaining an incorrect measurement. If necessary, drive it in fully with a suitable drift.

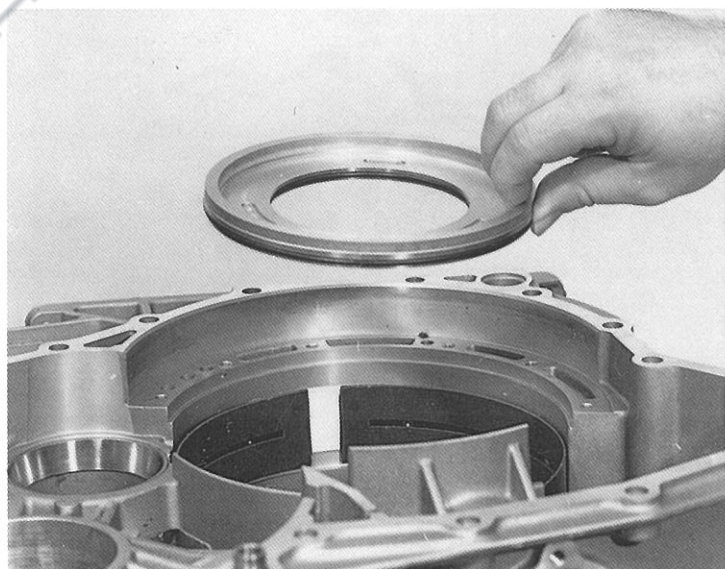

Insert cup spring 17.040.

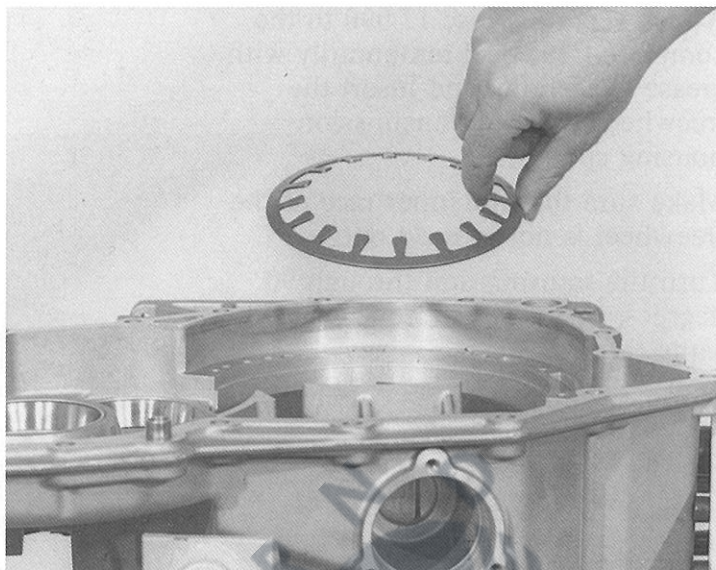

First install the two outer races of taper roller bearings 14.050 in freewheel inner race 17.160. To do this, heat the freewheel inner race to app. 70°C.



Press the freewheel inner race fully into freewheel 17.110. To do this, hold the freewheel firmly and turn the inner race clockwise.

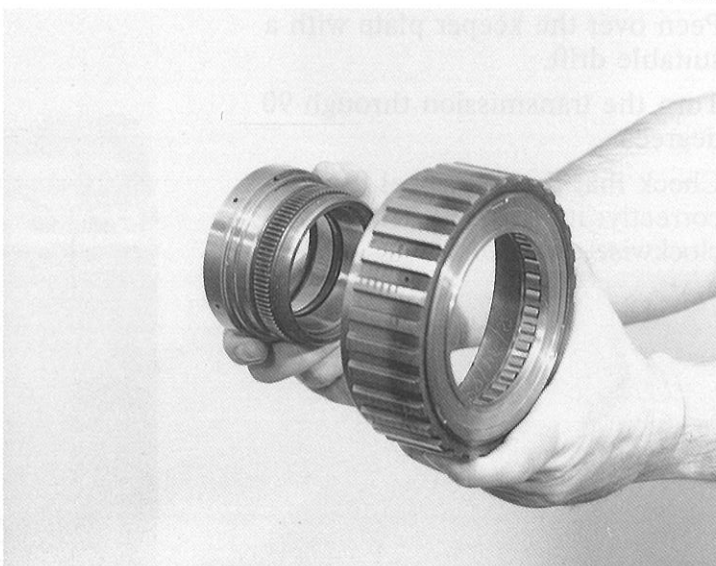



Attach retaining disc 17.090 to the complete freewheel temporarily with grease (Vaseline), and insert the freewheel into the transmission housing splines.

Make sure that the inner race of the freewheel is not pressed out.

Turn the transmission through 90 degrees, holding the freewheel at the same time.

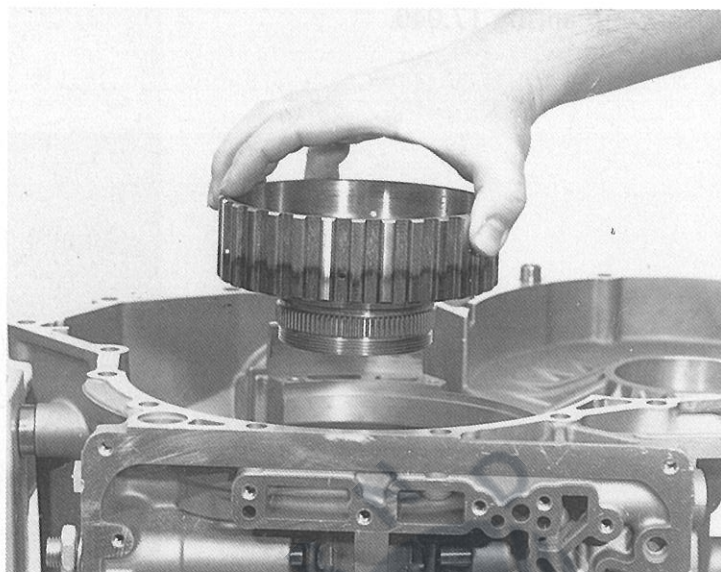

Attach keeper plate 17.170, with the retaining lug in the transmission housing. Screw on slotted nut 17.180 and tighten it with wrench 5 X 46 000 155.

(Tightening torque = 50 Nm.)

Make sure that the keeper plate is not jammed in the freewheel thread.

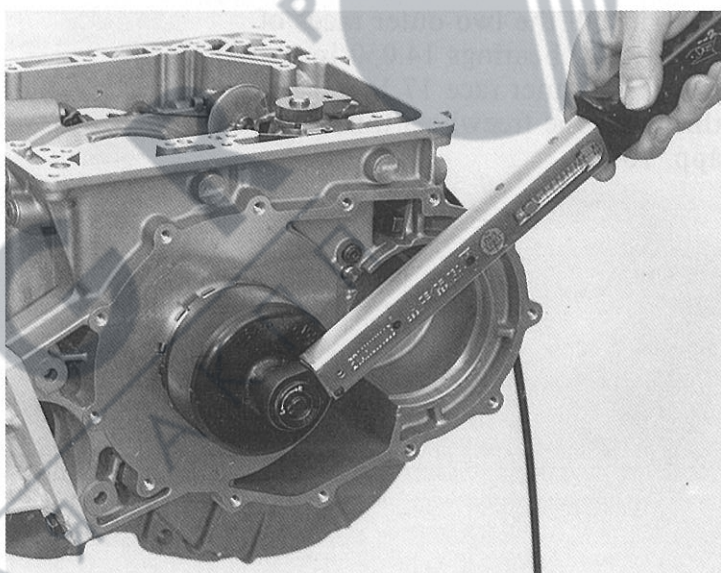

Peen over the keeper plate with a suitable drift.

Turn the transmission through 90 degrees.

Check that the freewheel functions correctly: it must turn freely in a clockwise direction.

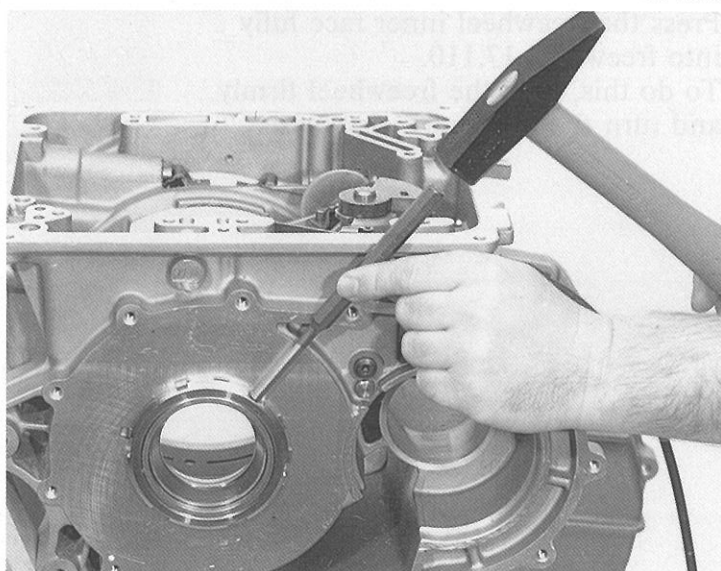



Insert the complete brake D plate cluster. Start with spring plate 17.046, followed alternately by outer plates 17.050 and lined plates 17.060. Install end plate 17.070 and secure with snap ring 17.080.

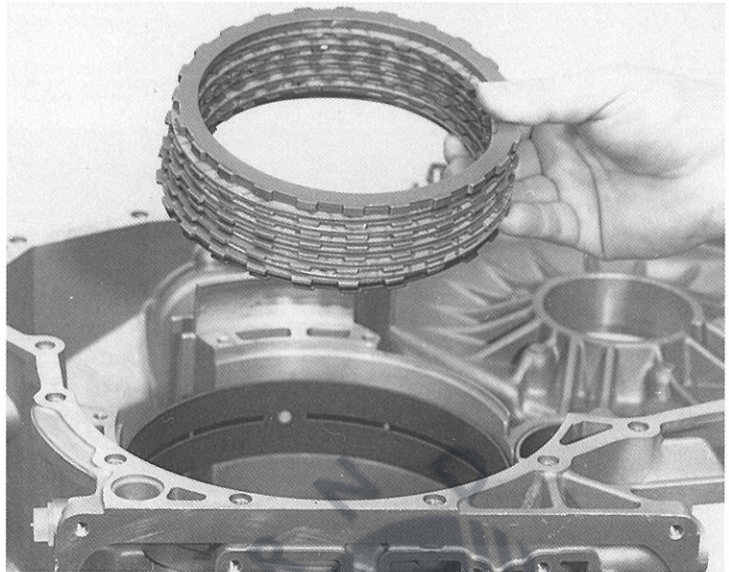

**Warning!**

Do not confuse the lined plates with clutch A.

Clutch A: with dots

Brake D: without dots.

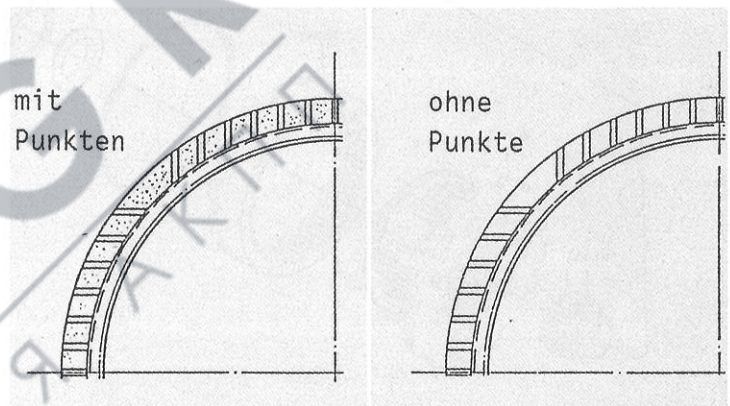

**Note:**

Adjustment work is needed.

Snap ring thickness must be determined (see Item 1.4.2, Page 5/2).

85 235

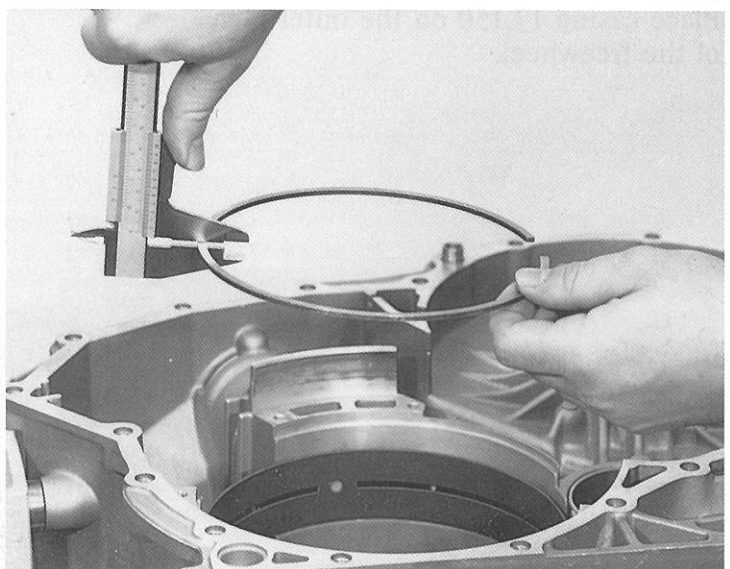



### 3.4 Planetary gear set with input and output components

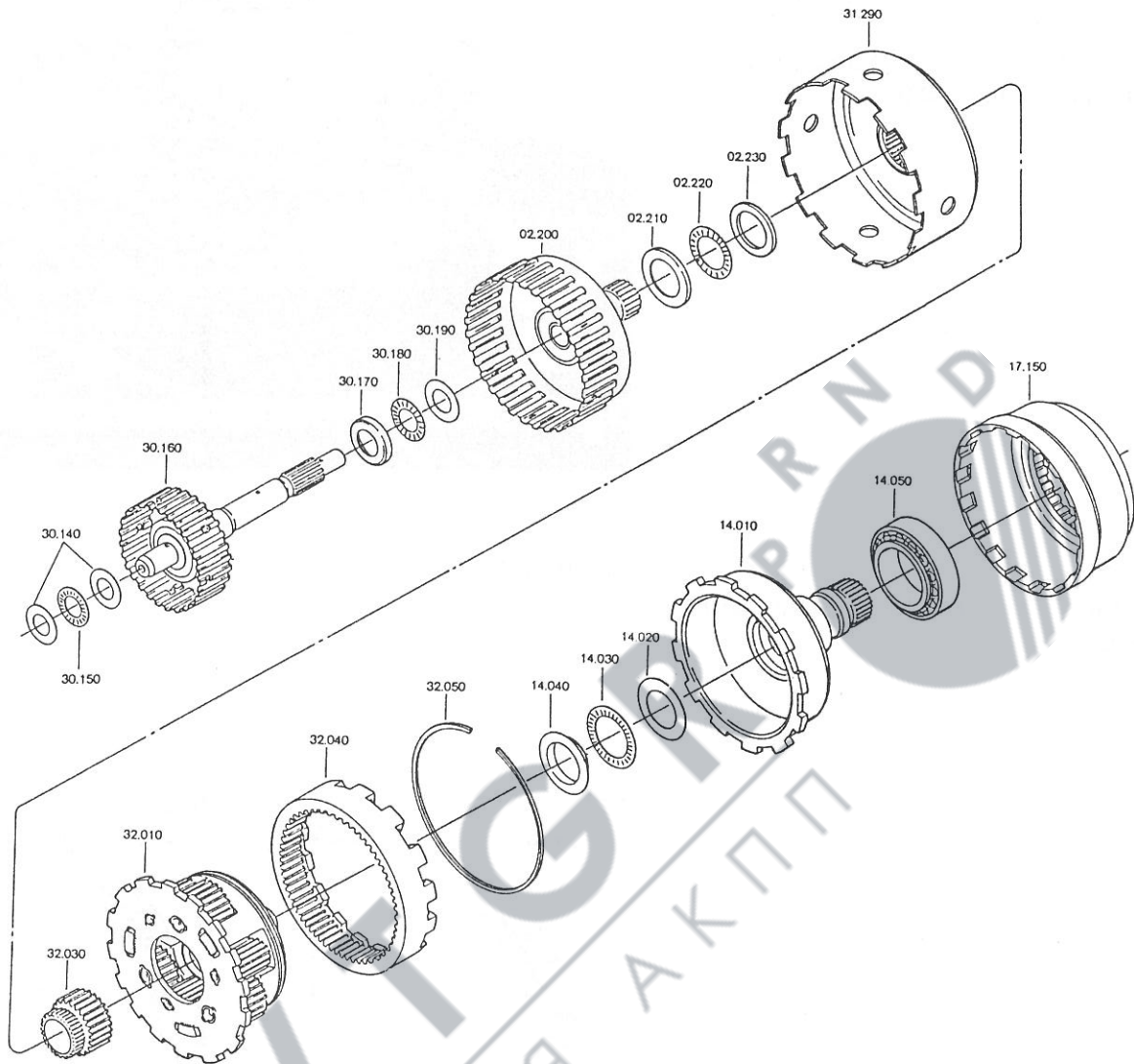

Place casing 17.150 on the outer race of the freewheel.

85246

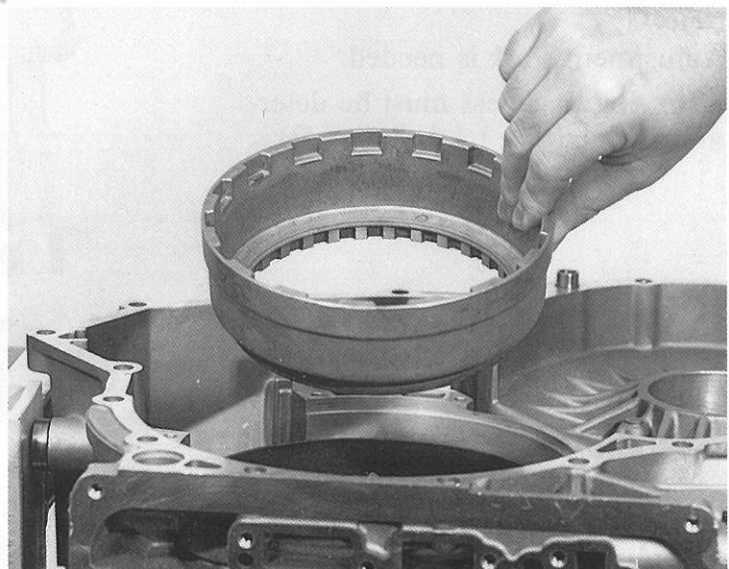

Use a press with a suitable arbor and assembly sleeve 5 X 46 000 300 to force taper roller bearing inner race 14.050 on to output shaft 14.010.

The shaft should be supported on a suitable underlay.

**Warning:**

Do not rest it on the sheet metal edge.

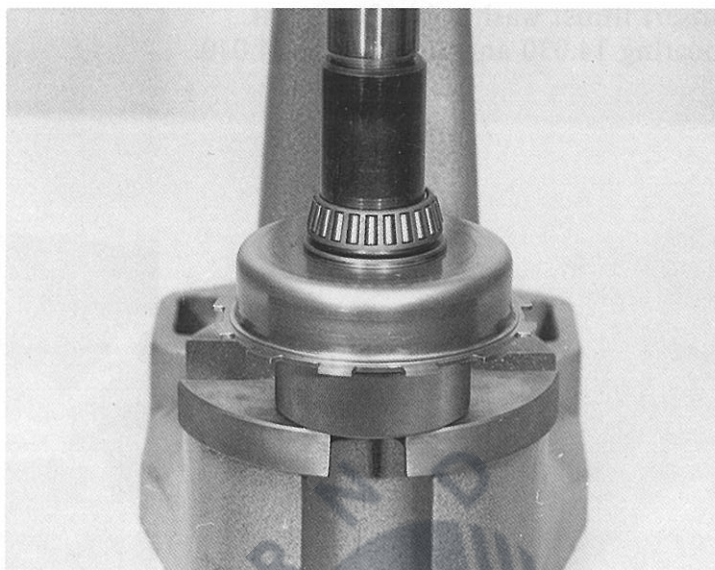

Insert the output shaft into annulus 32.040 and secure with snap ring 32.050.

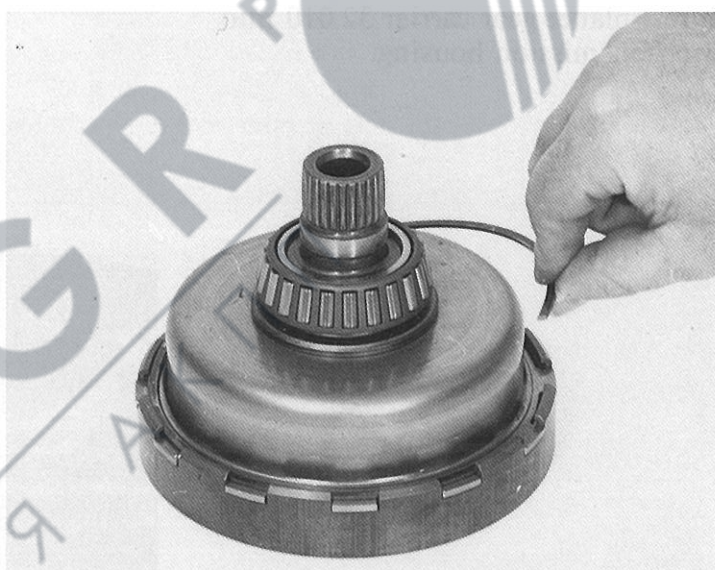

Insert the output shaft with the annulus into the transmission housing.

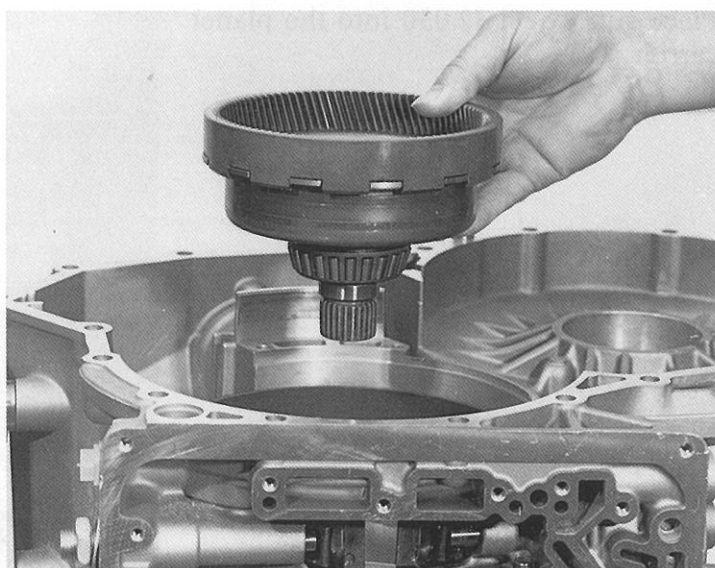



Insert thrust washer 14.020, thrust bearing 14.030 and angled disc 14.040.

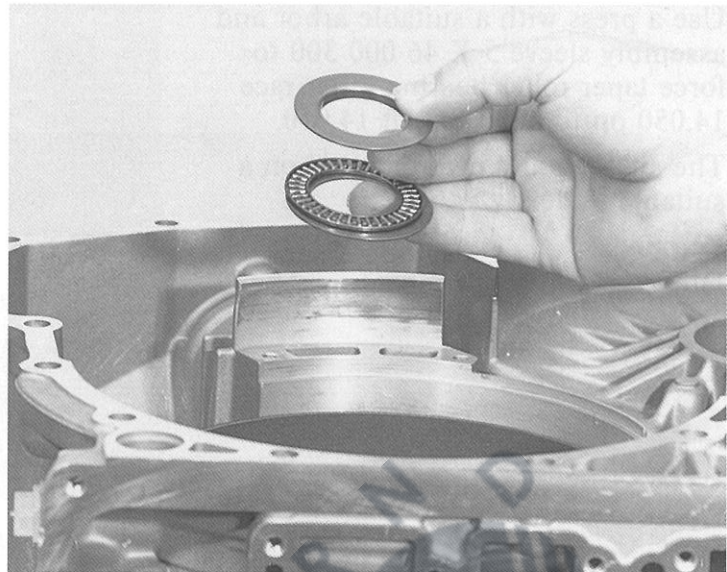

Insert planet gear carrier 32.010 into the transmission housing.

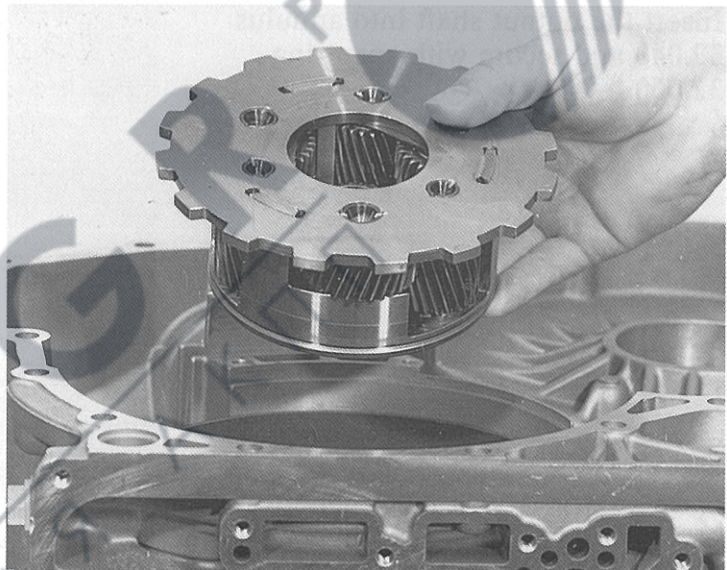

Place sun wheel 32.030 into the planet carrier plate.

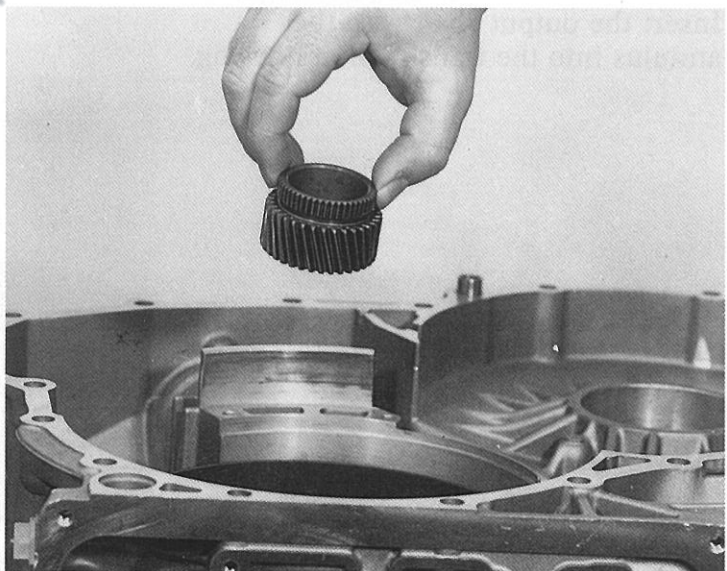



Place casing 31.290 on the sun wheel splines.

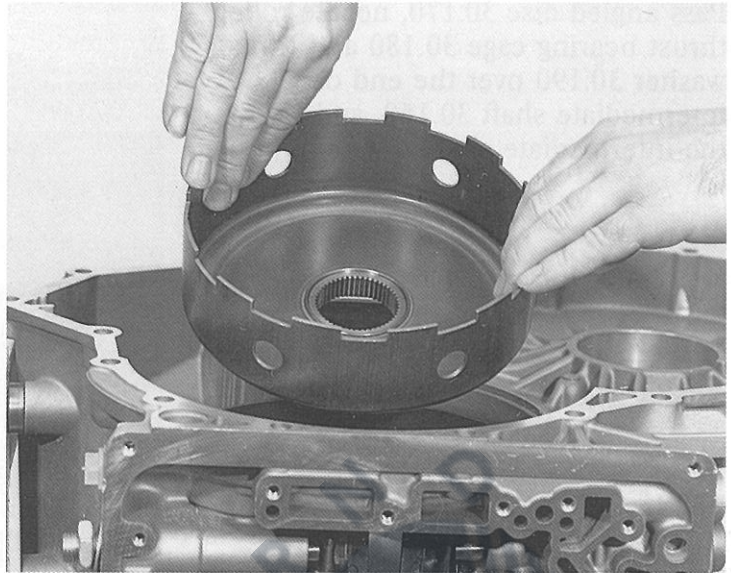

Insert thrust washer 02.230, needle roller thrust bearing 02.220 and angled disc 02.210 into the casing.

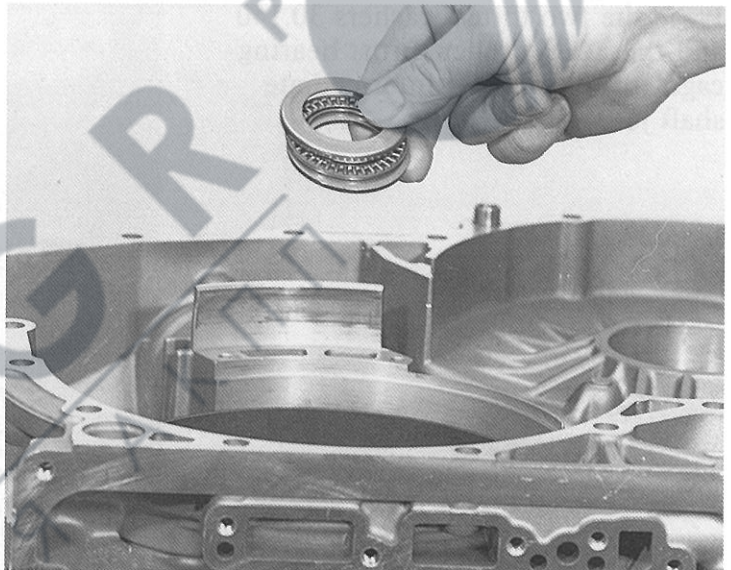

Insert sun wheel shaft 02.200 and check that the assembly functions correctly.  
If correctly assembled, the casing will turn in the opposite direction to the sun wheel shaft.

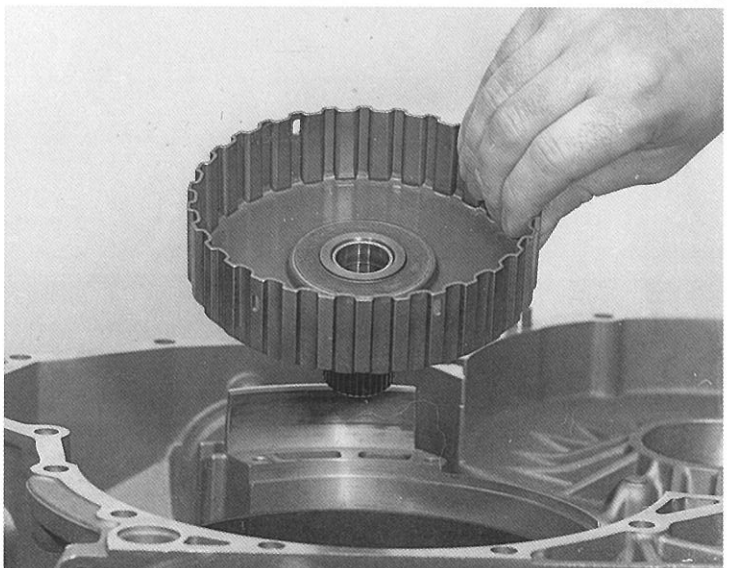



Pass angled disc 30.170, needle roller thrust bearing cage 30.180 and thrust washer 30.190 over the end of intermediate shaft 30.160, and insert the intermediate shaft.

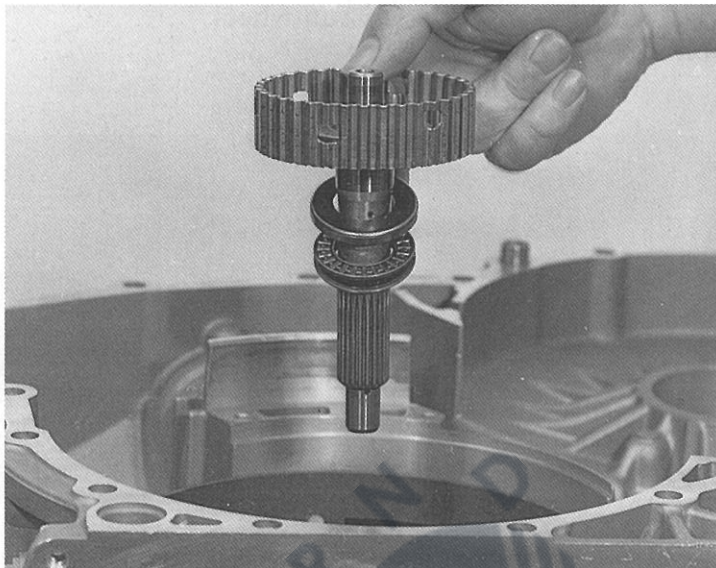

Place the two thrust washers 30.140 and the needle roller thrust bearing cage 30.150 over the intermediate shaft journal.

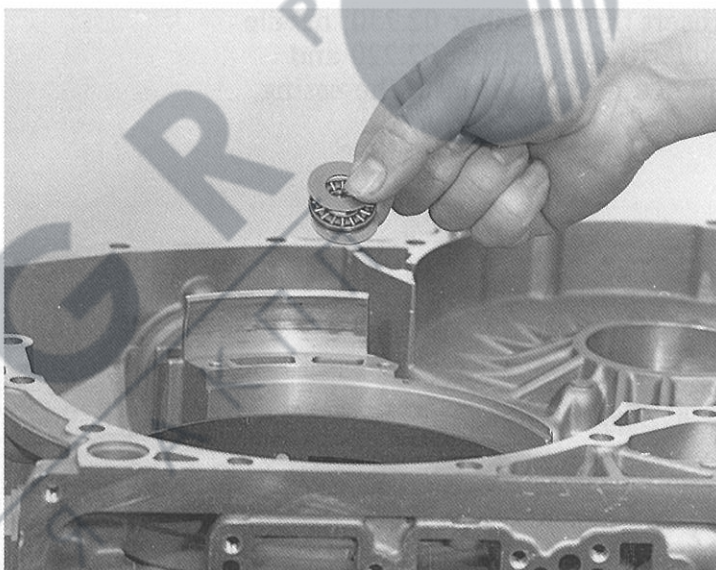

### 3.5 Engine shaft with clutch E

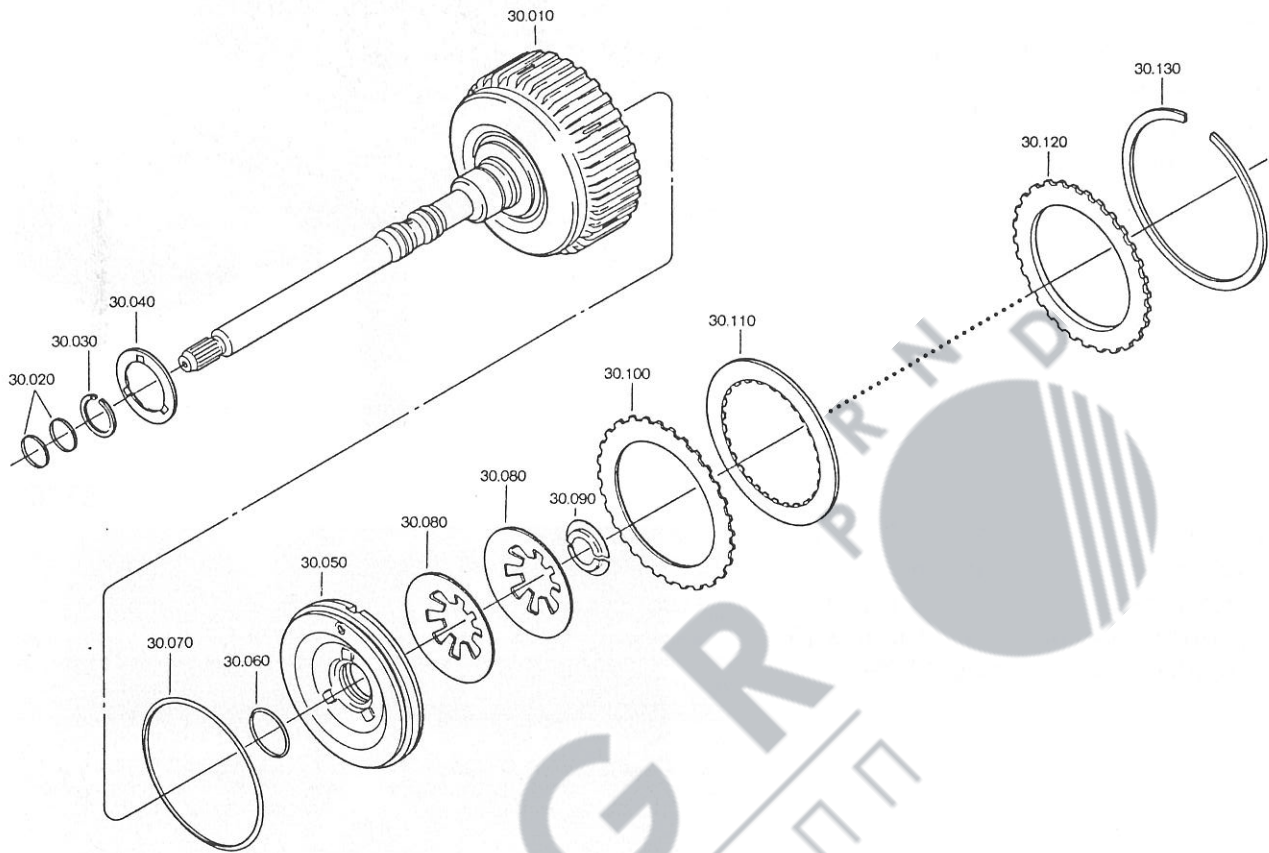

Install new sealing rings 30.060 and 30.070 on piston E 30.050, and grease lightly (with Vaseline).

85 258

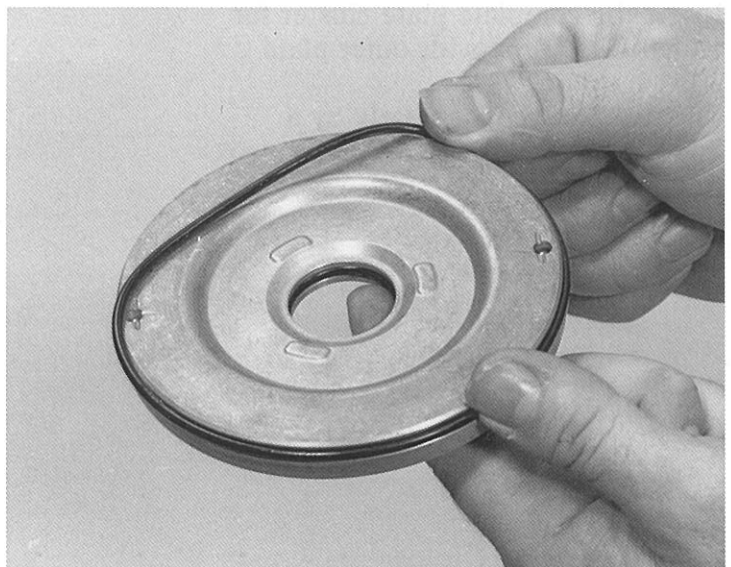



**Note:**

You are recommended to check the correct functioning of the lubrication pressure valve in the engine shaft first.

Apply a compressed air jet to the shaft opening (outer splines).

Press piston E into complete engine shaft cylinder 30.010.

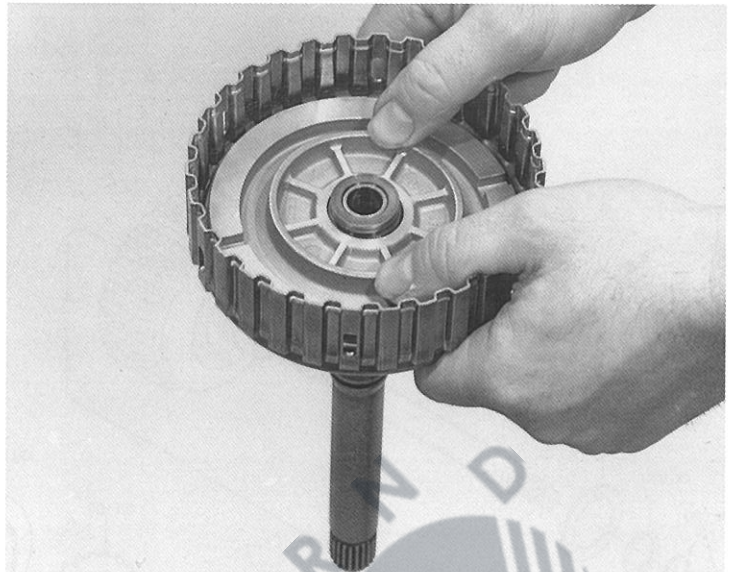

85260

Place the two cup springs 30.080 on the piston, press them down with assembly fixture 5 X 46 000 148 in the arbor press and secure them with the divided retaining ring 30.090.

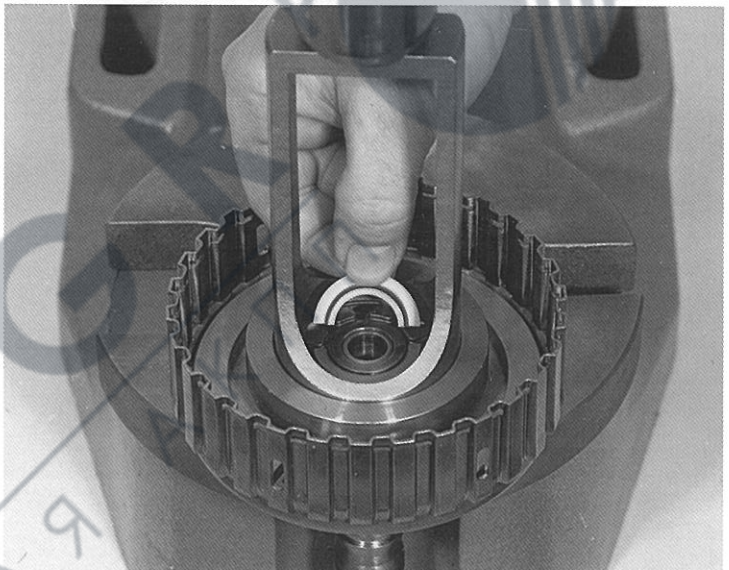

85261

Insert the complete plate cluster for clutch E, starting with outer plate 30.100. This is followed alternately by a lined plate 30.110 and an outer plate.

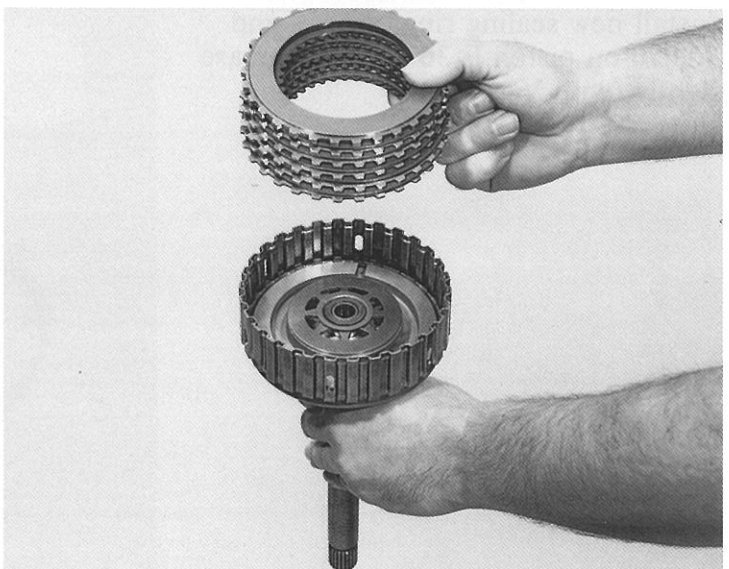

Place end plate 30.120 on the last lined plate; note that on the version with 5 pairs of plates the end plate has its turned recess facing outwards. Secure the plate cluster with snap ring 30.130.

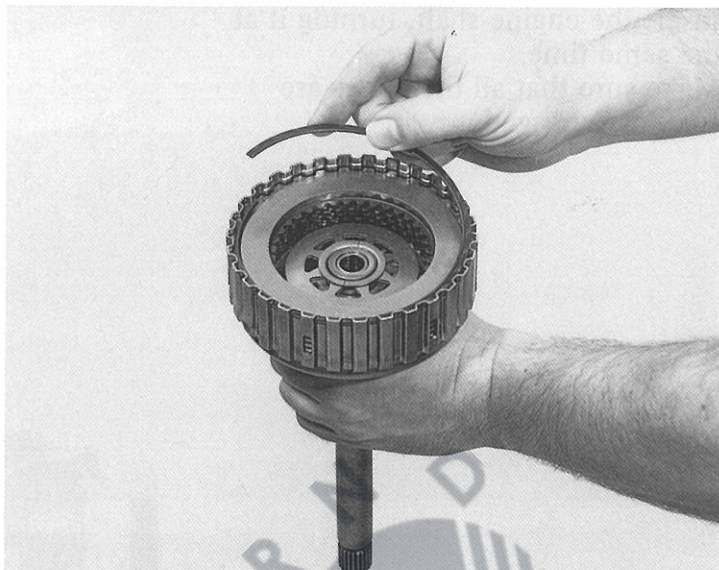

Install the two rectangular-section rings 30.020 and the rectangular-section ring 30.030 on the engine shaft, snap them into position and coat them with Vaseline.

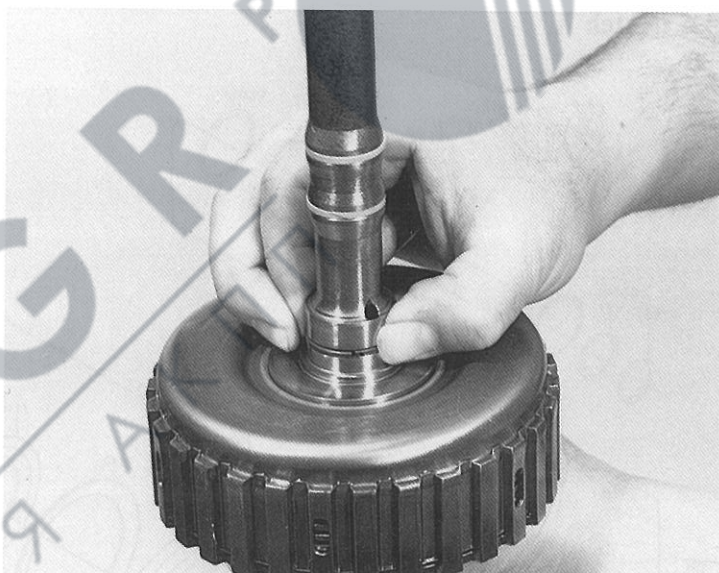

Install and centre thrust washer 30.040.

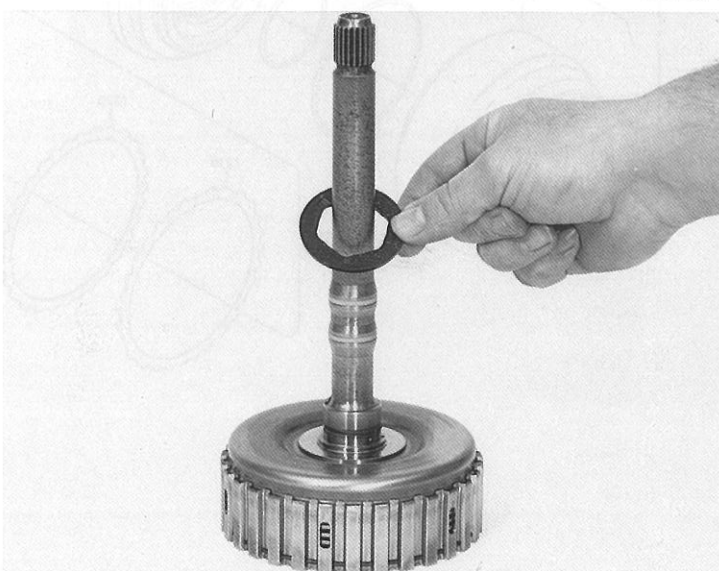



Insert the engine shaft, turning it at the same time.  
Make sure that all the plates are correctly engaged.

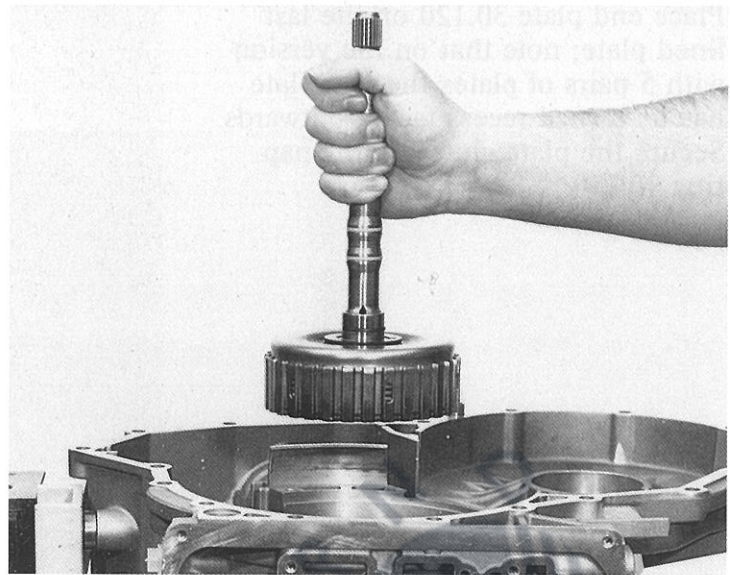

### 3.6 Clutch A

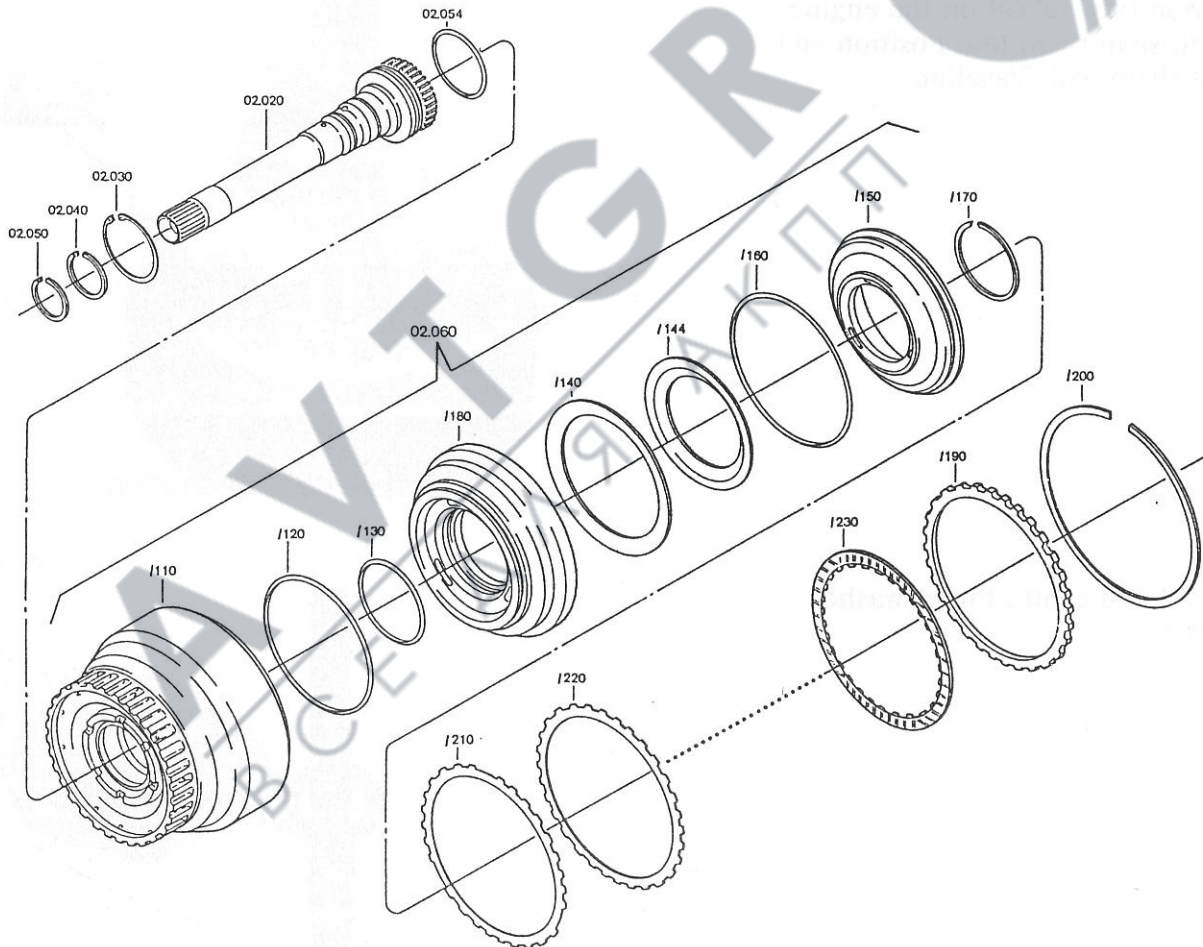

Install new sealing rings 02.060/120 and 02.060/130 on piston 02.060/180, and grease lightly (with Vaseline).



Press piston A into cylinder A 02.060/110 and insert the cup spring 02.060/140 with the curve facing upwards.

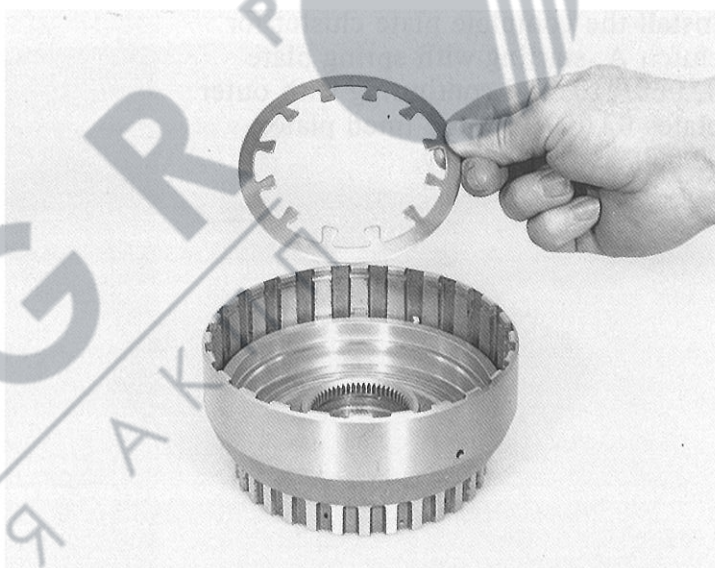

Pull sealing ring 02.060/160 on to retaining disc 02.060/150 and grease lightly (with Vaseline).

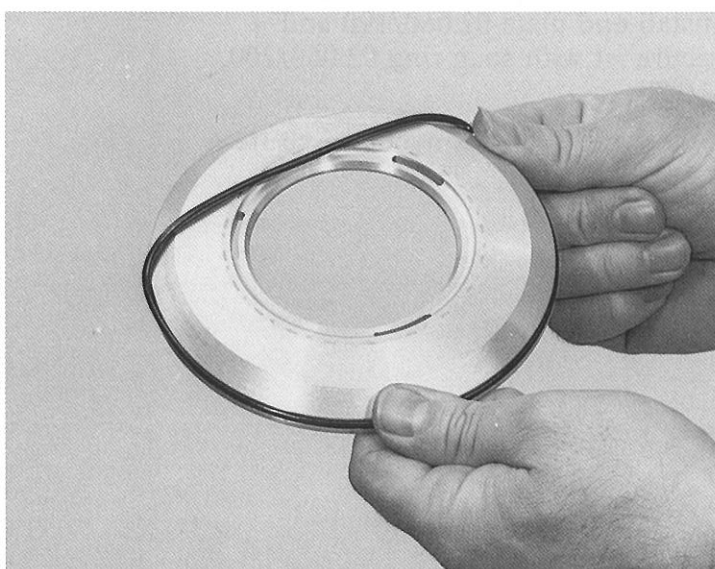



Insert the retaining disc and press it down in the arbor press, using the hoop of tool 5 X 46 000 167.  
Snap ring 02.060/170 can be inserted by hand, or if necessary with the aid of suitable pliers.

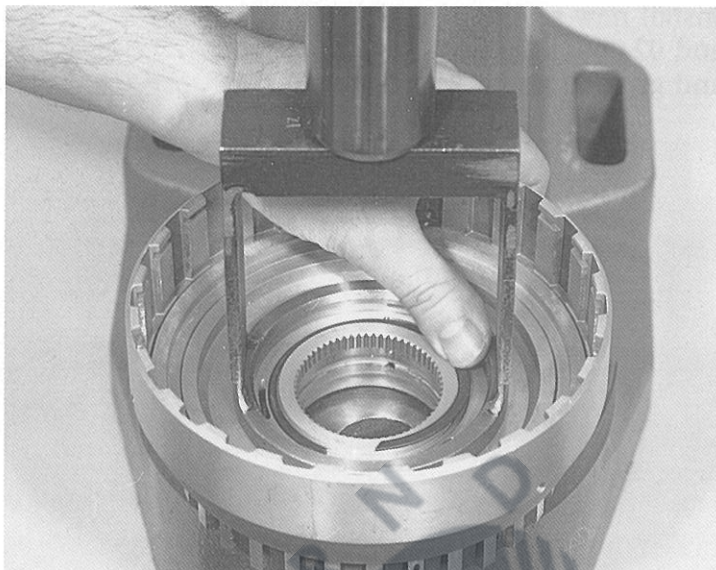

Install the complete plate cluster for clutch A, starting with spring plate 02.060/210, and continuing with outer plates 02.060/220 and lined plates 02.060/230 alternately.

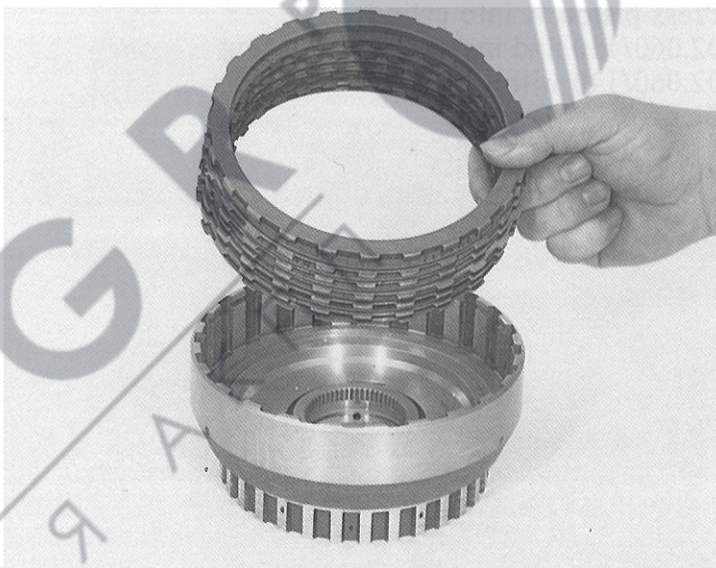

Install end plate 02.060/190 and secure it with snap ring 02.060/200.

**Note:**

Adjustment work is needed (see Item 1.4.3, Page 5/3).

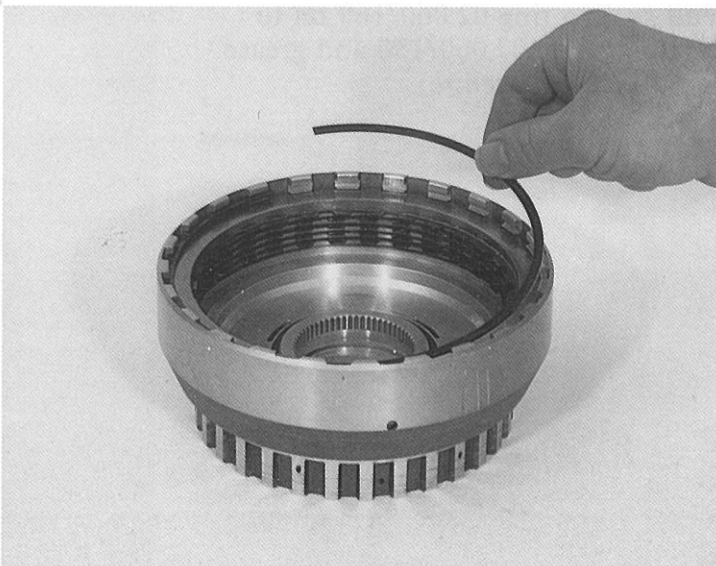

Install the two rectangular-section rings 02.040 and 02.050 on turbine shaft 02.020, and hook them into place.

Pull on O-ring 02.054 and grease lightly (with Vaseline).

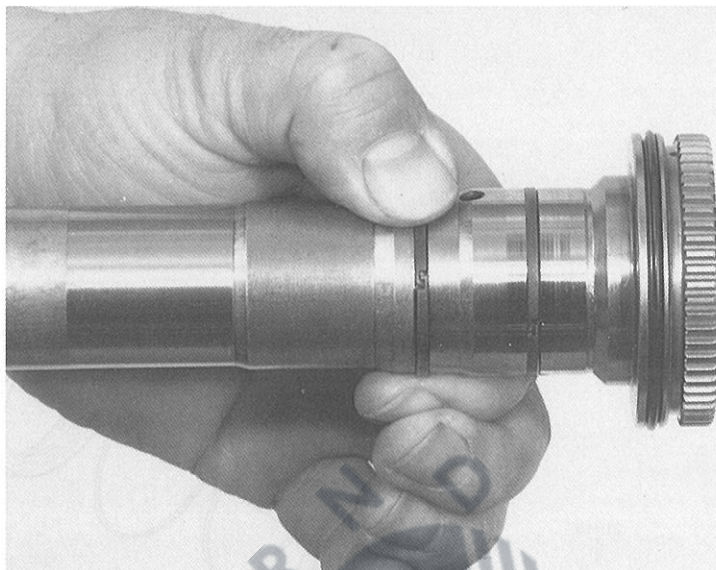

Press the turbine shaft into cylinder A and snap in circlip 02.030 with pliers.

**Warning:**

Pull the turbine shaft in flush with the circlip, or else endplay will not be correct.

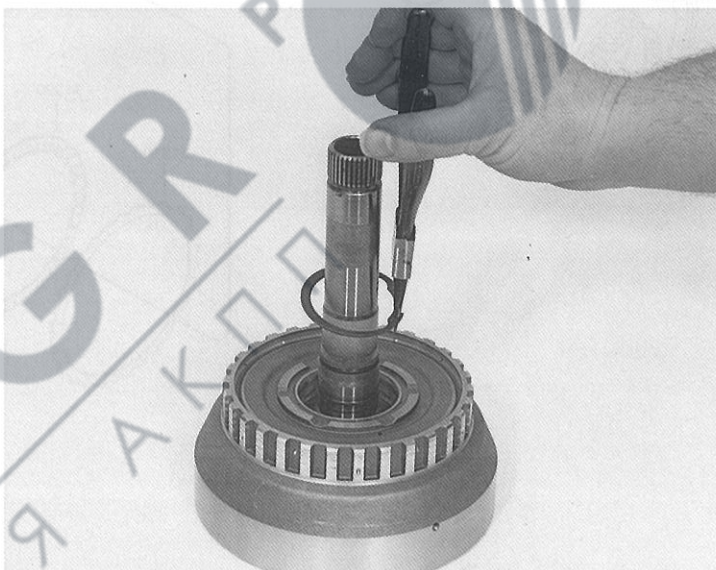

Insert the complete clutch A, turning it to and fro until the plate splines engage.

**Warning:**

The thrust washer on the engine shaft must be centred. If installed correctly, the engine shaft projects about 21 mm beyond the turbine shaft.

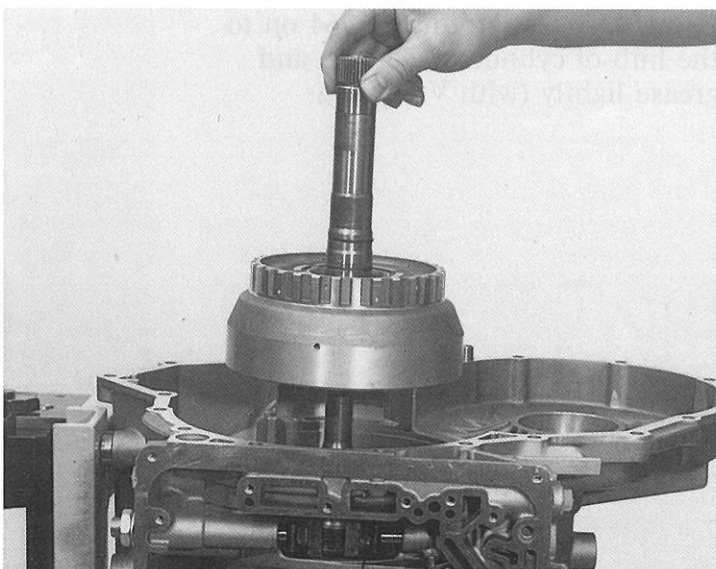



### 3.7 Clutch B

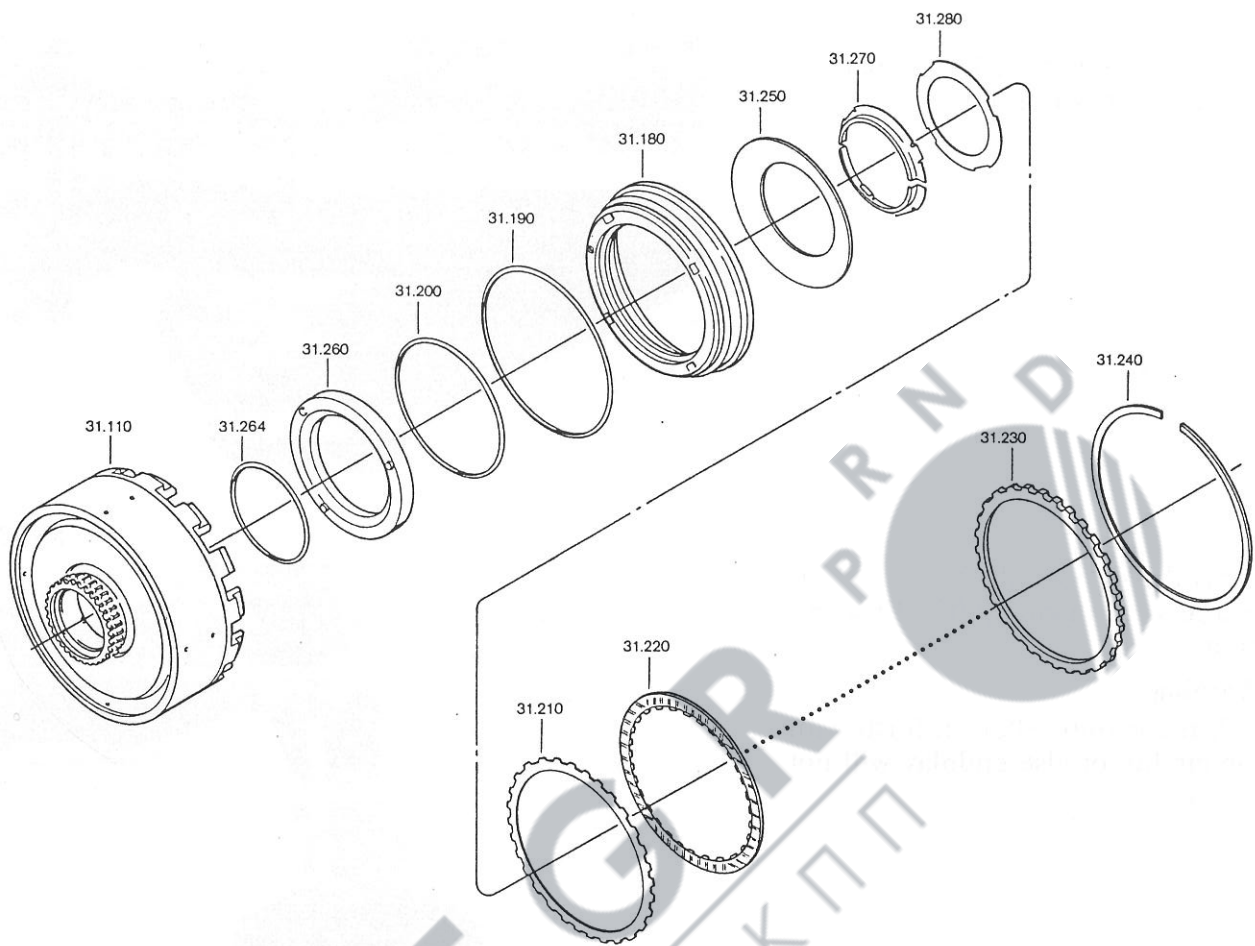

Pull a new sealing ring 31.264 on to the hub of cylinder B 31.110, and grease lightly (with Vaseline).

85277

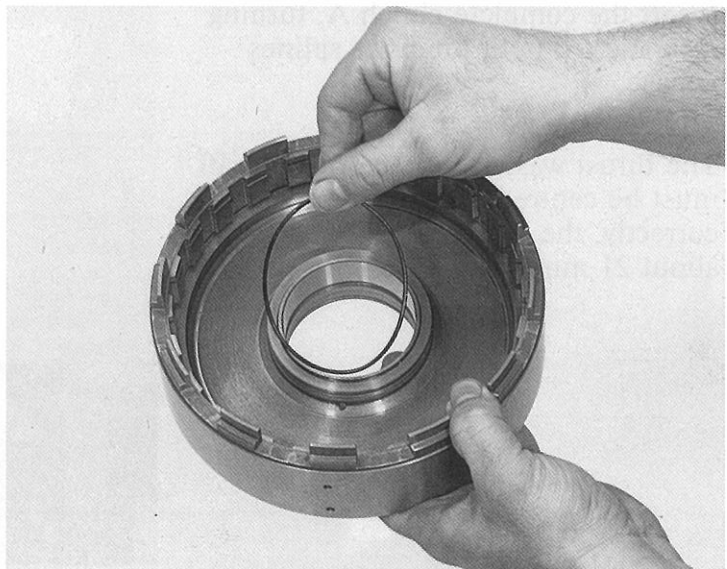

85278

Press intermediate ring 31.260 fully into the cylinder with the chamfer at the bottom.

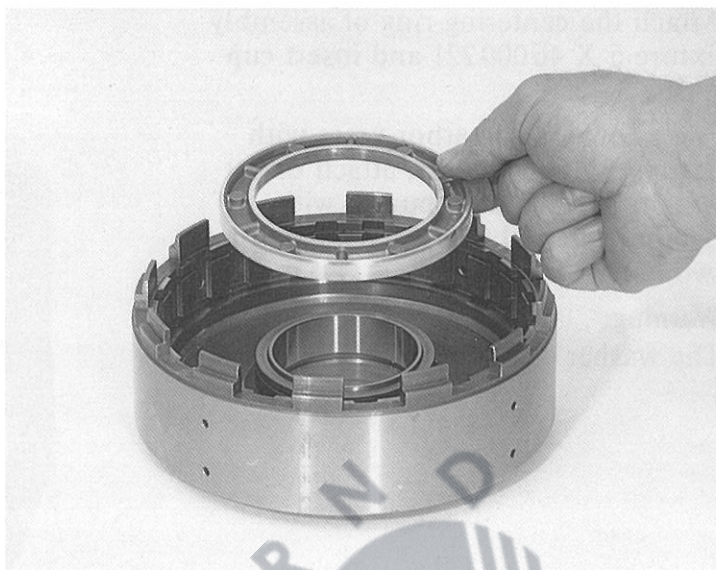

85279

Pull new sealing rings 31.190 and 31.200 on to piston B 31.180, and grease lightly (with Vaseline).

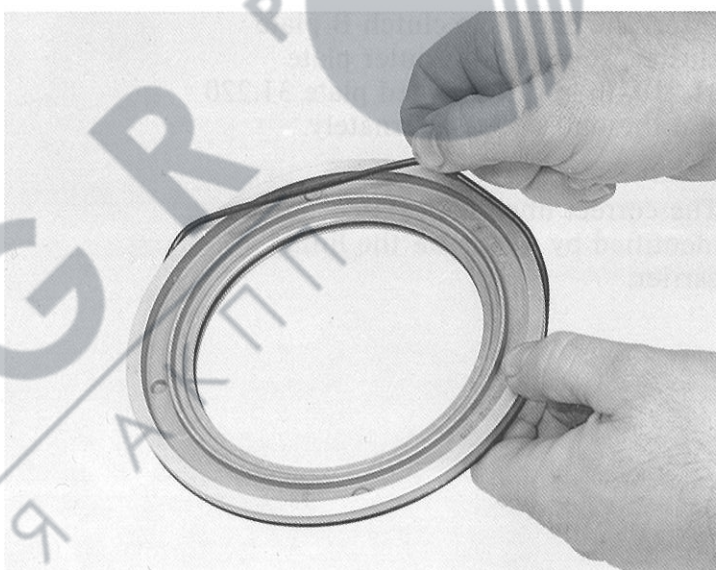

85280

Press the piston into the cylinder.

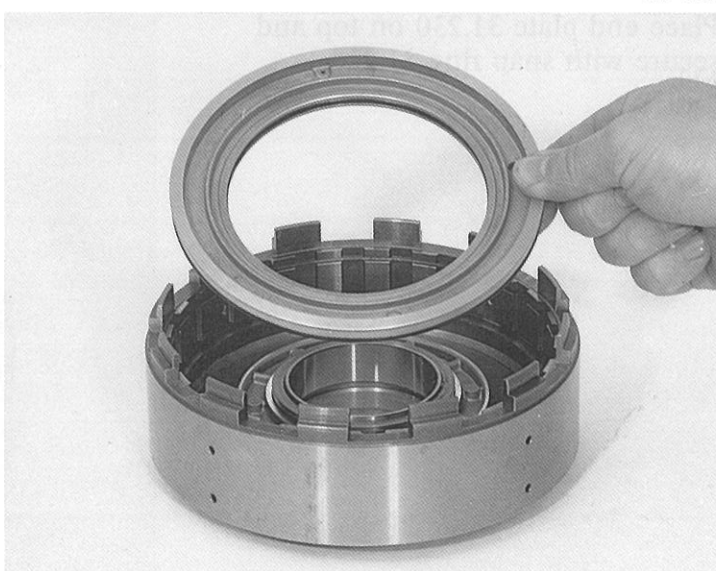



Attach the centering ring of assembly fixture 5 X 46000221 and insert cup spring 31.250.

Press down in the arbor press with fixture 5 X 46 000 221, attach thrust washer 31.280 and secure it with retaining ring 31.270 (by pushing the two halves together).

**Warning:**

The washer must turn freely.

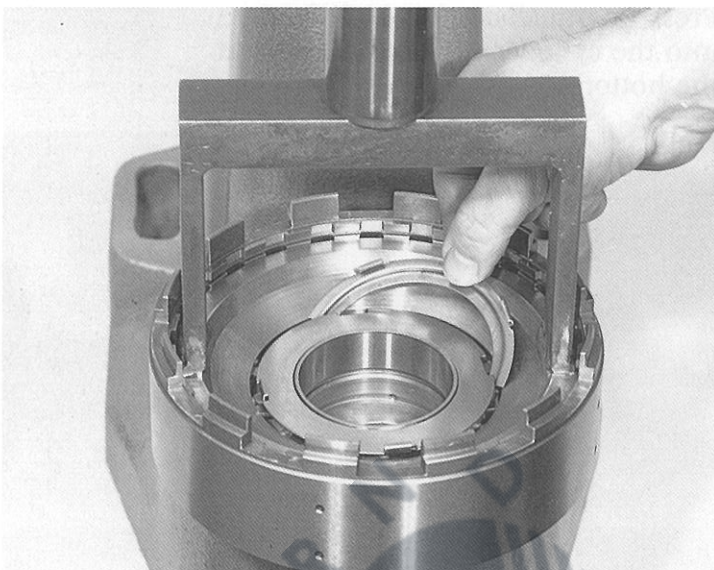

Insert the complete clutch B plate cluster, starting with outer plate 31.210, followed by lined plate 31.220 and the outer plate alternately.

**Note:**

The correct lined plates are identified by a hole on the lining carrier.

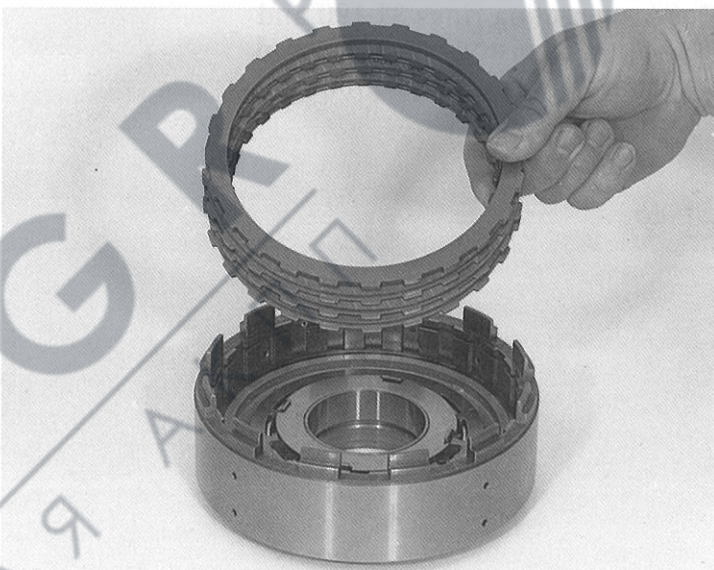

Place end plate 31.230 on top and secure with snap ring 31.240.

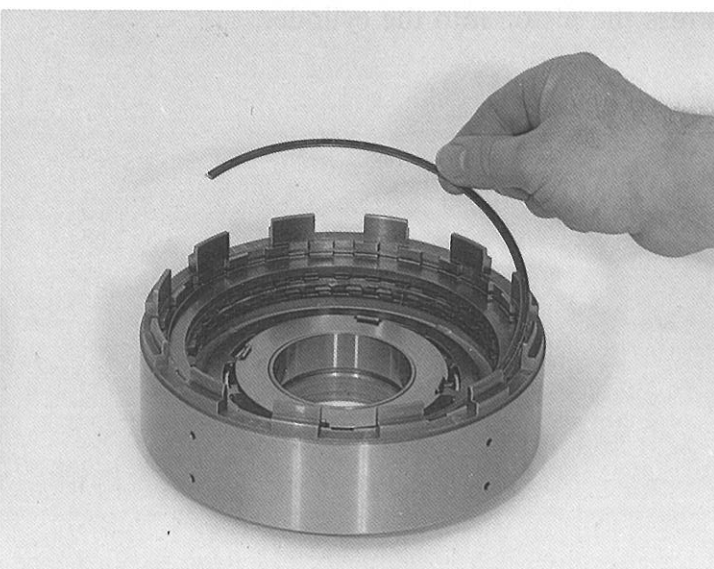

Install the complete clutch B, turning to and fro until the plates engage with each other fully.

If correctly installed, cylinder B must engage in the cutouts of the casing so that a gap of only app. 1 mm is visible.

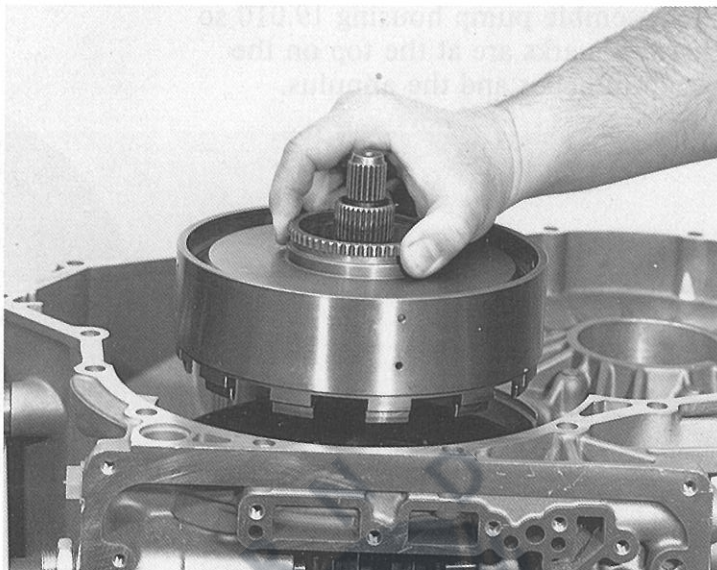

### 3.8 Intermediate plate with pump and brake C, 2nd gear freewheel

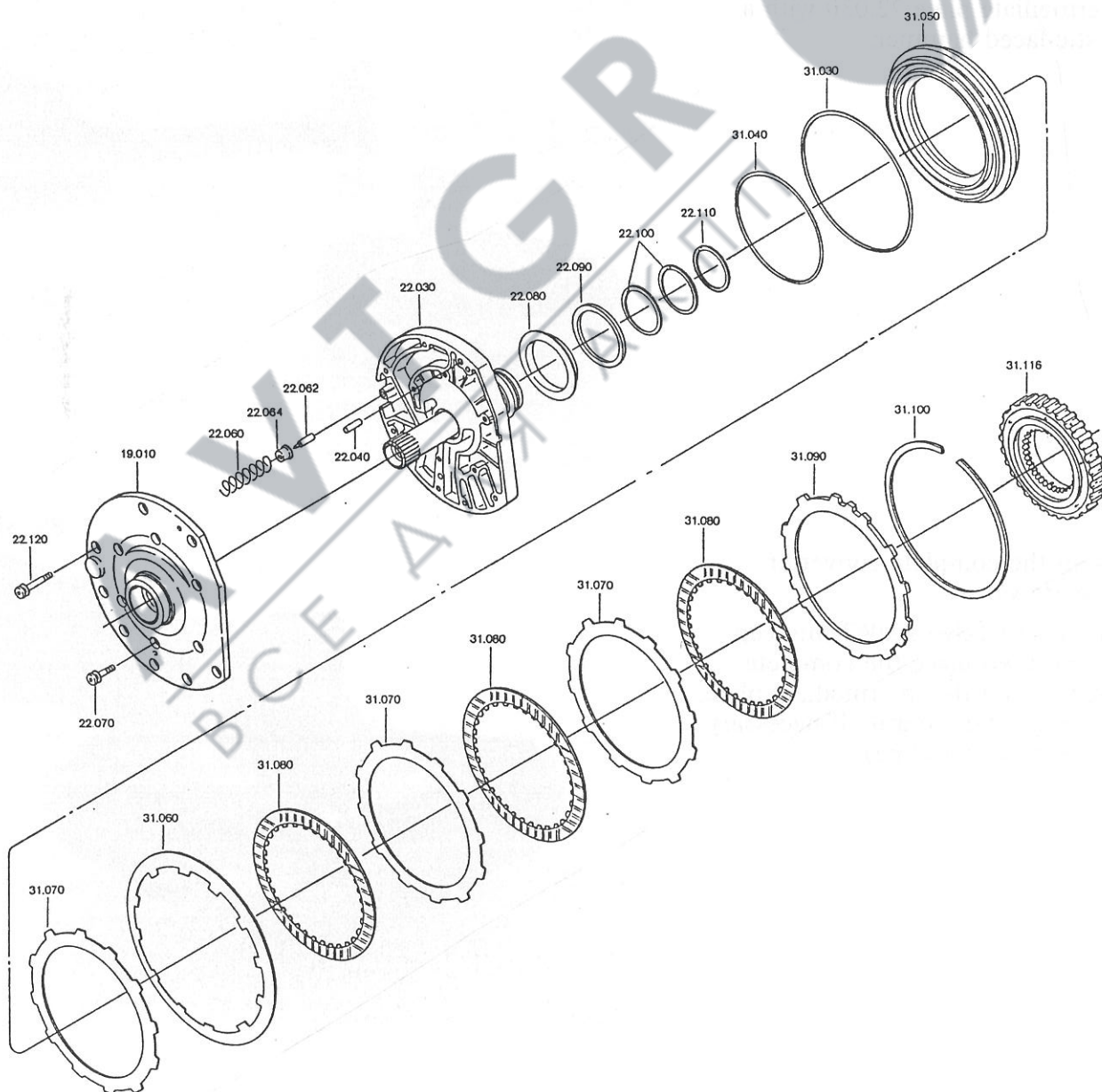



Pre-assemble pump housing 19.010 so that the marks are at the top on the pump impeller and the annulus.

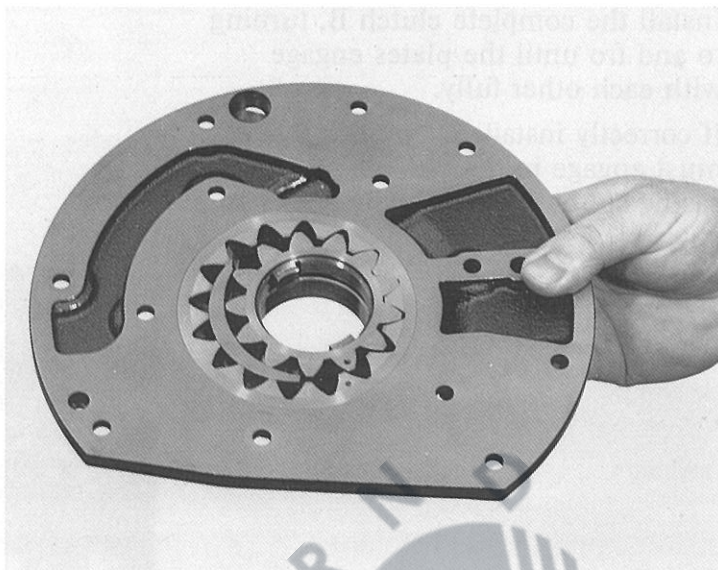

Drive two dowel pins 22.040 into intermediate plate 22.030 with a plastic-faced hammer.

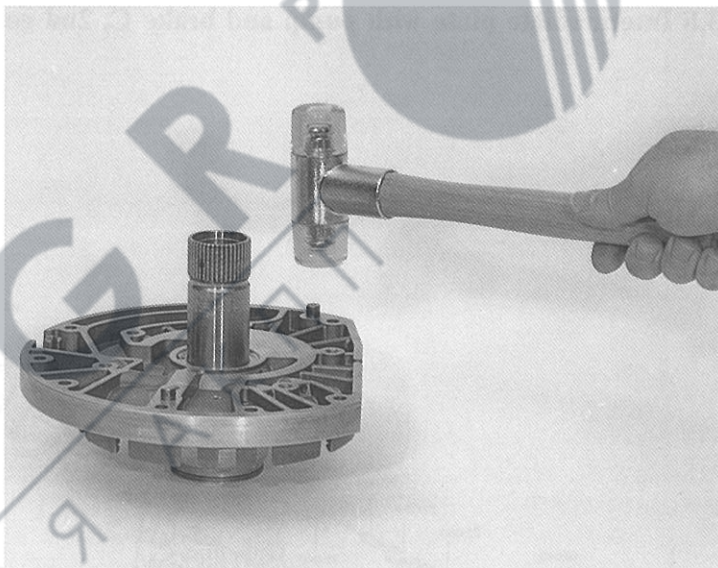

Install the complete converter pressure valve.

First insert valve 22.062 into cap 22.064, then place the complete assembly on the intermediate plate, securing it temporarily if necessary with grease (Vaseline).

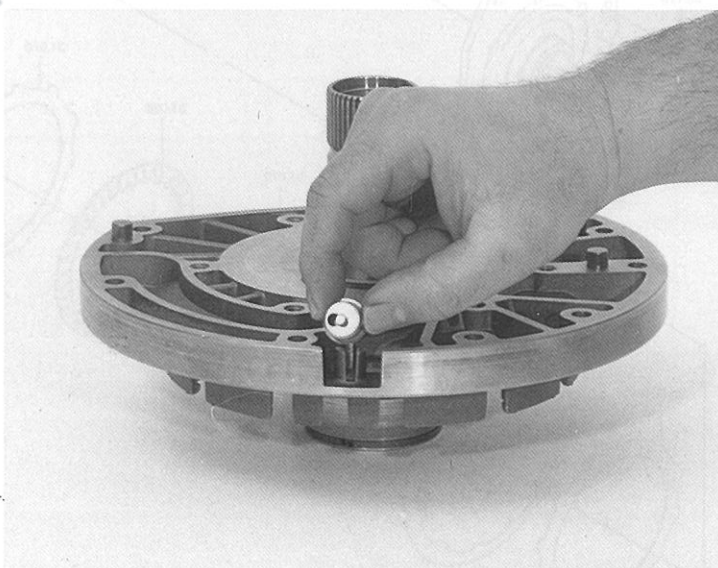



Insert coil spring 22.060 into the cutout on the pump.

Attach the intermediate plate to the pump and align it.

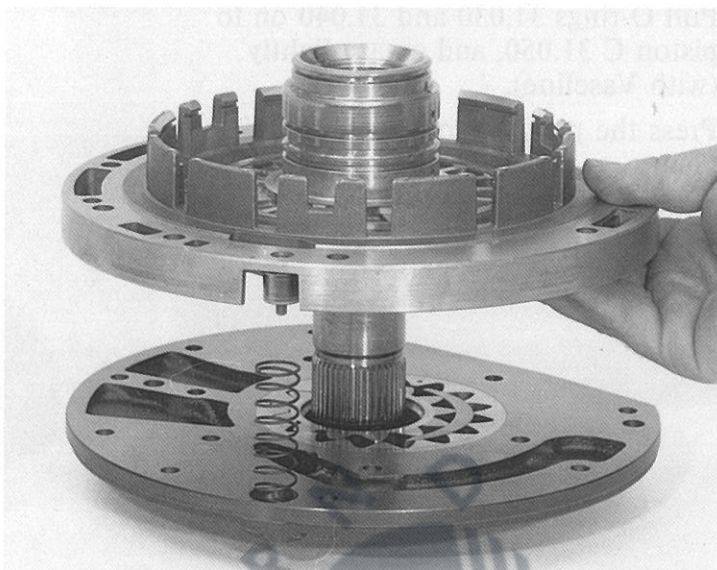

Press the intermediate plate and pump housing together, turn them round as a complete unit and secure with the 6 machine screws 22.070.

(Wrench size = TX 27 TORX insert.)

(Tightening torque = 10 Nm.)

Check that the converter pressure relief valve moves freely.

Check free movement of the pump with tool 5 X 46 000 306.

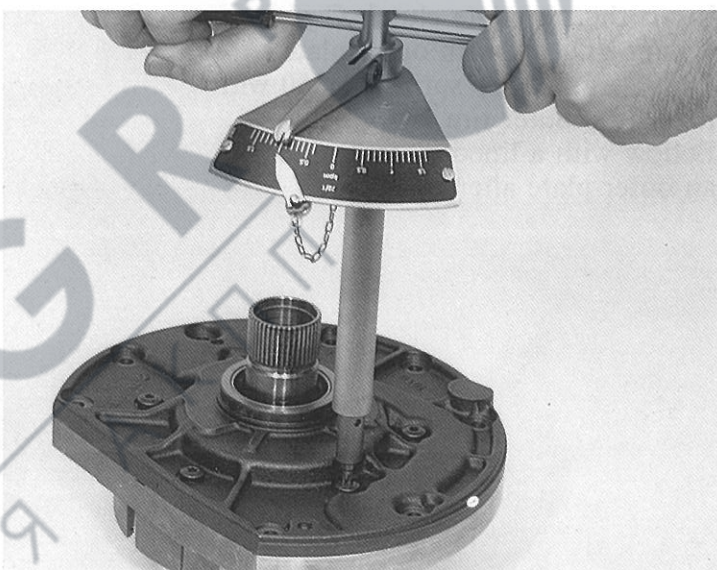

Install and snap in the two rectangular-section rings 22.100 and rectangular-section ring 22.110 on the hub of the intermediate plate.

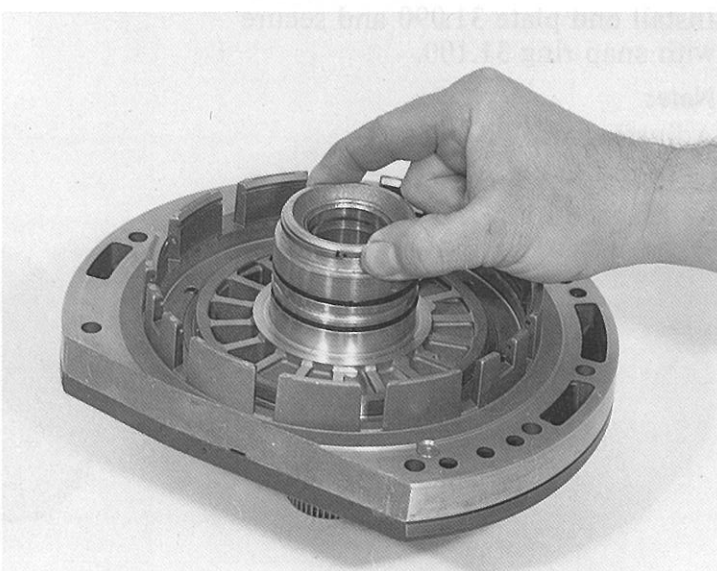



Pull O-rings 31.030 and 31.040 on to piston C 31.050, and grease lightly (with Vaseline).

Press the piston into the intermediate plate.

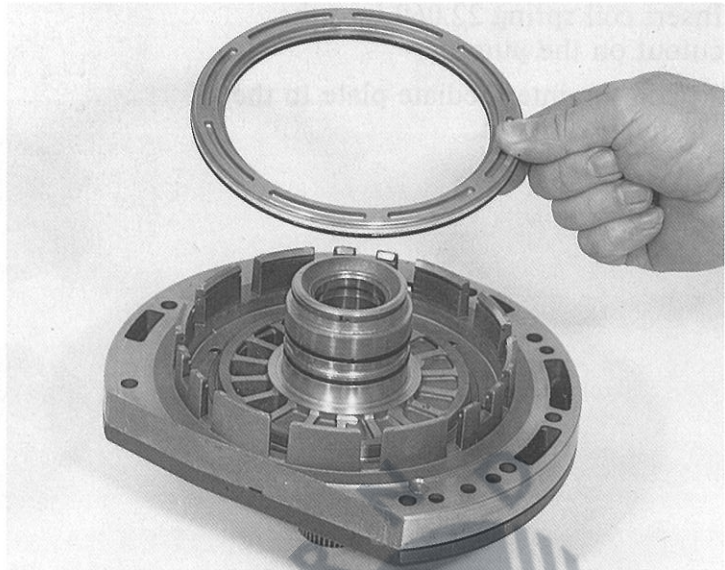

Insert the complete clutch C plate cluster, starting with outer plate 31.070. Insert cup spring 31.060 with the raised outer rim facing in. Follow with a lined plate 31.080 and an outer plate alternately.

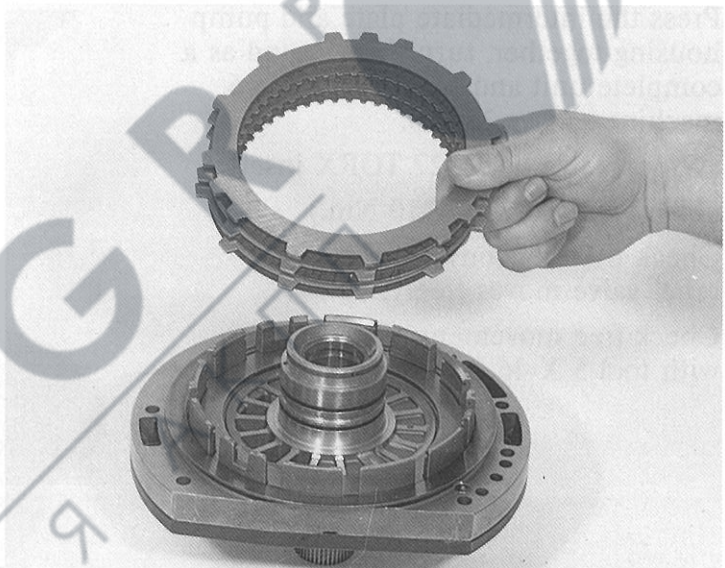

Install end plate 31.090 and secure with snap ring 31.100.

**Note:**

Adjusting work is needed.

Snap ring thickness must be determined (see Item 1.4.4, Page 5/4).

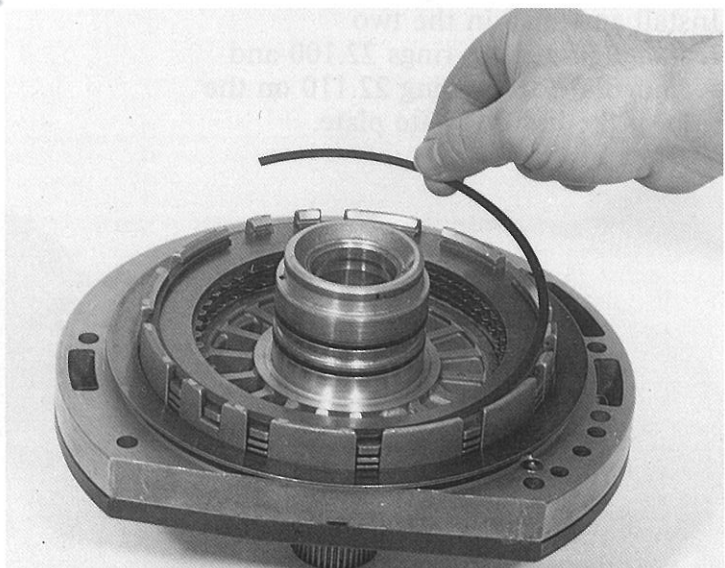

Pre-assemble 2nd gear freewheel 31.116, first pressing one of the two cover discs into the outer race of the freewheel.

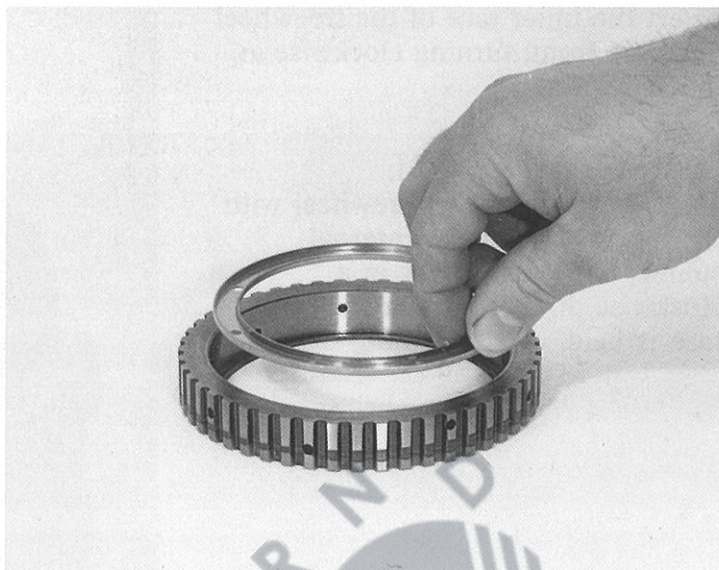

Insert the freewheel cage with the shoulder facing down.

**Warning:**

If installed incorrectly (upside-down, the freewheel's locking direction will be incorrect.



Attach the cover disc and press it in.

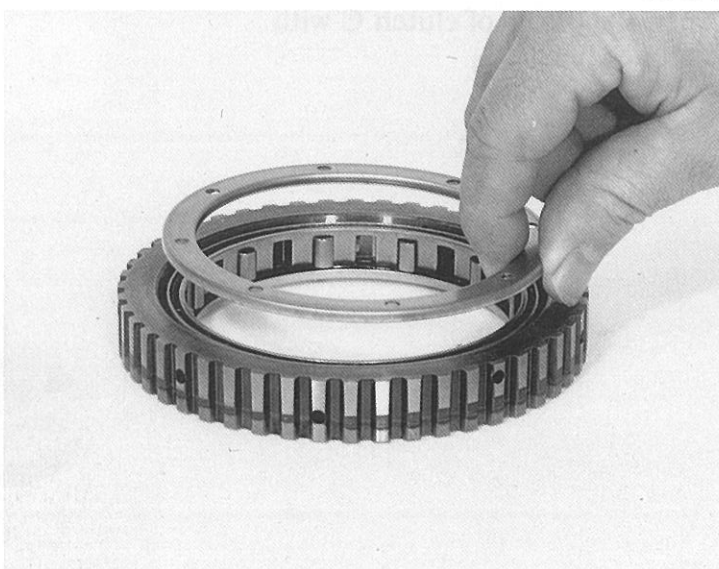



Insert the inner race of the freewheel from the front, turning clockwise at the same time.

**Note:**

Check correct operation:  
The inner race of the freewheel with the facing shoulder or internal splines must turn freely in a clockwise direction when the outer race is held.

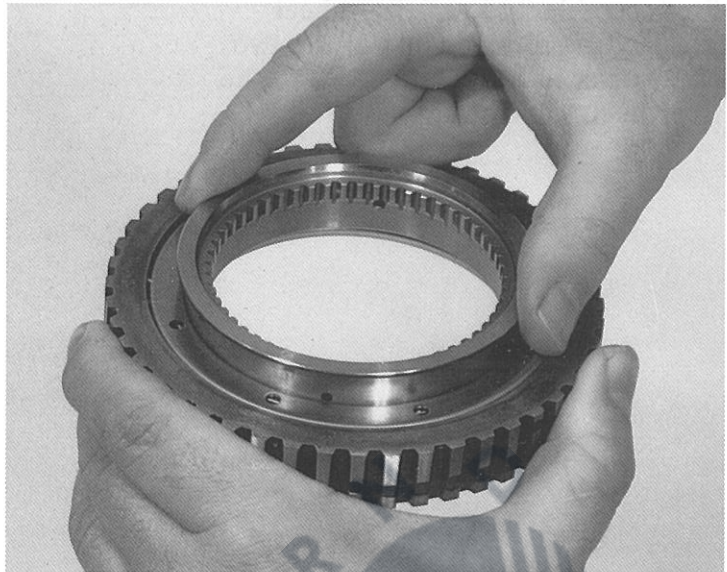

Before installing shim washer 22.090, its thickness must be determined.

**Note:**

Adjustment work (see Item 1.4.5, Page 5/5).

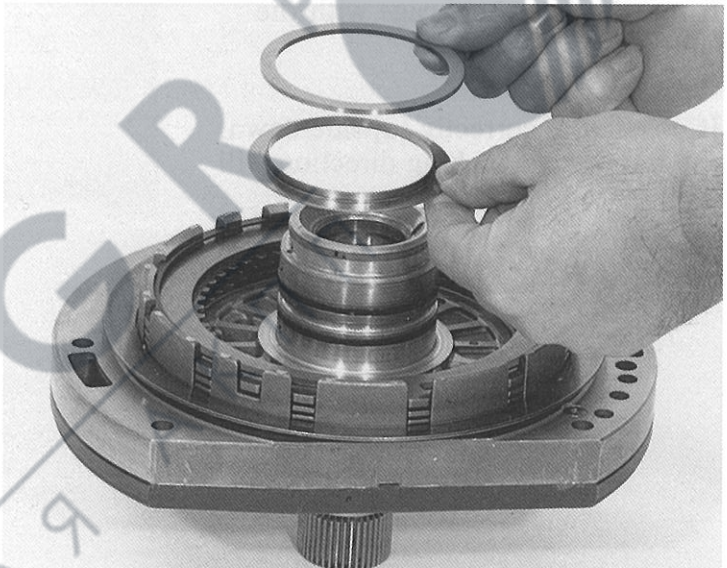

Align the plates of clutch C with the freewheel.

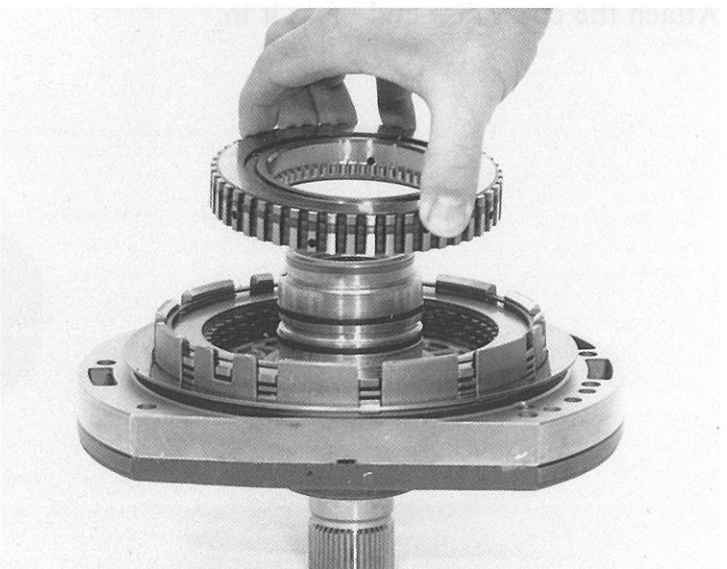

90072

Attach the complete freewheel with the internal splines at the top to the hub of cylinder B.

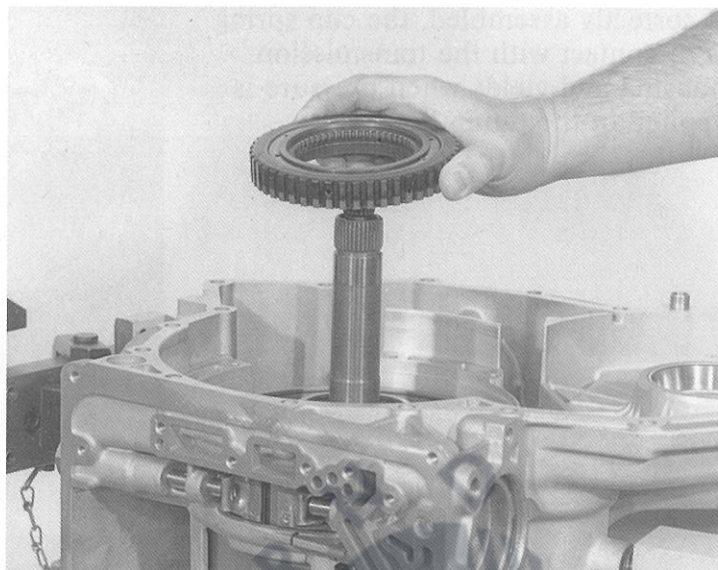

90073

Insert the shim washer of the calculated thickness, and angled disc 22.080.

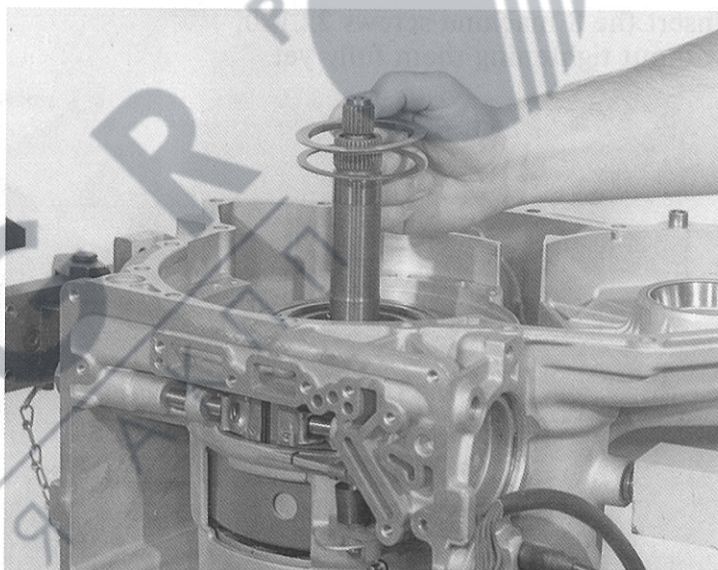

90074

Install the complete unit (pump, intermediate plate and 2nd gear freewheel) in the transmission housing, turning it to and fro at the same time.

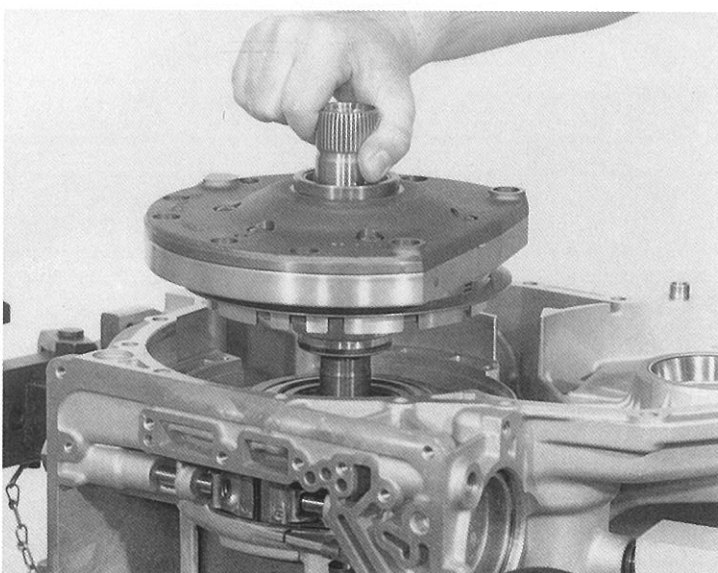



If correctly assembled, the cup spring is in contact with the transmission housing and yields when pressure is applied of the pump housing.

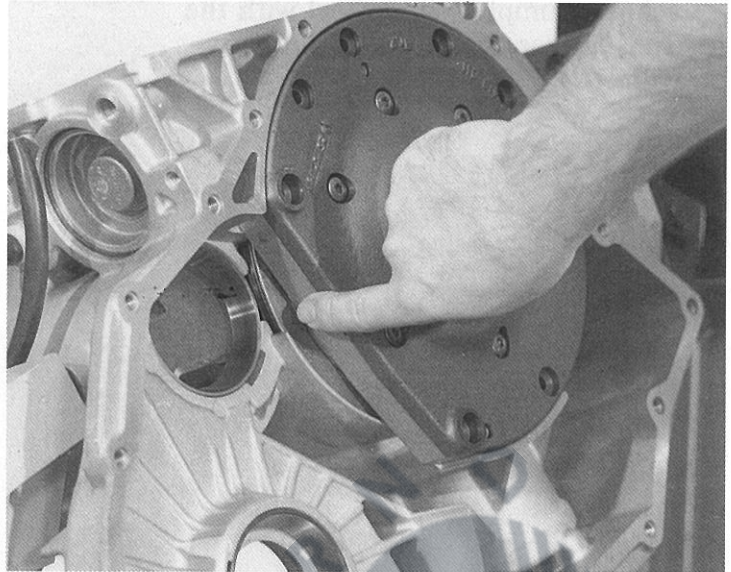

Insert the 8 machine screws 22.120, without tightening them fully yet.

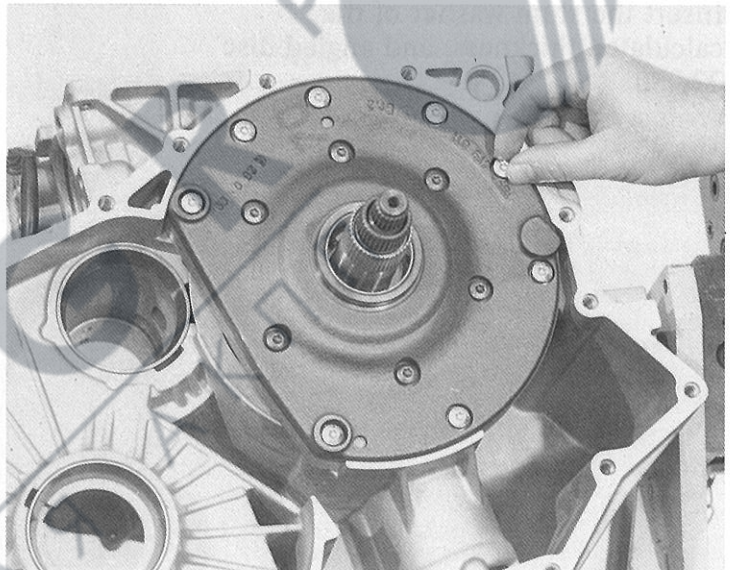

AVT  
BCEAM

AVT  
BCEAM

### 3.9 Governor, side shaft and spur gear drive

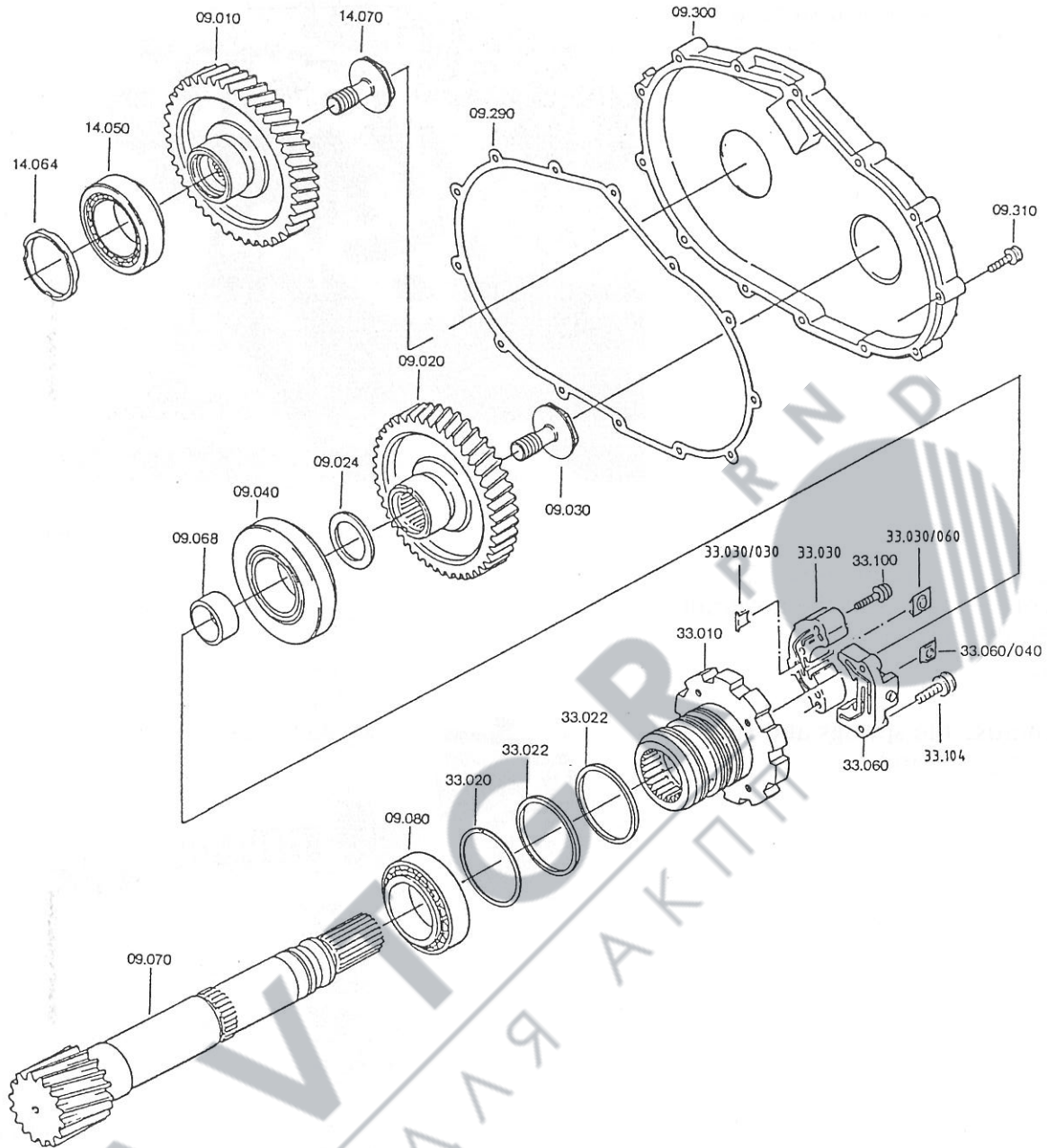

The picture on the right shows the components of stages 1 and 2 of the governor housing in the correct order of assembly.

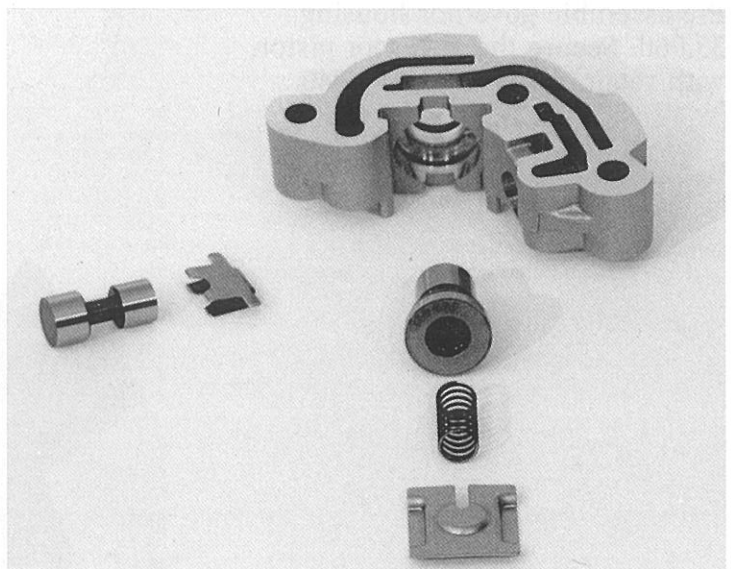

88 203



Pre-assemble governor housing 33.030. Secure the two governor pistons with stop plate 33.030/030 and retaining plate 33.030/060.

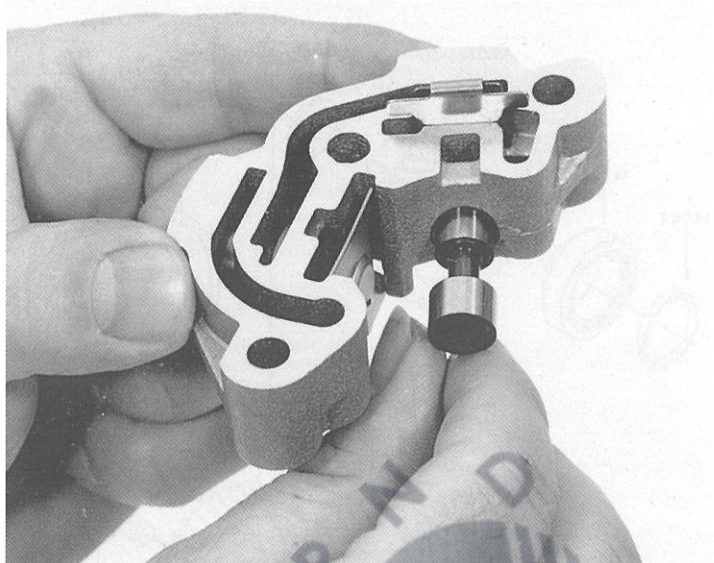

The picture on the right shows the components of stage 3 of the governor housing in the correct order of assembly.

**Warning:**

Do not confuse the springs and stop plates for stages 2 and 3.

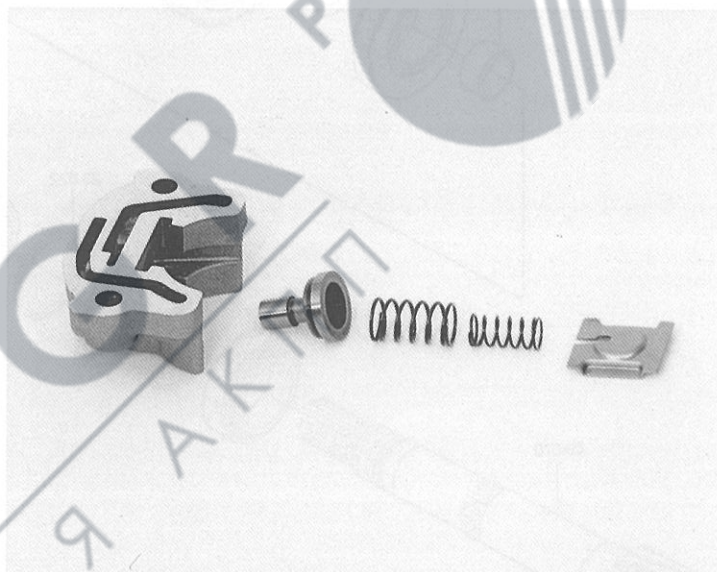

Pre-assemble governor housing 33.060. Secure the governor piston with retaining plate 33.030/040.

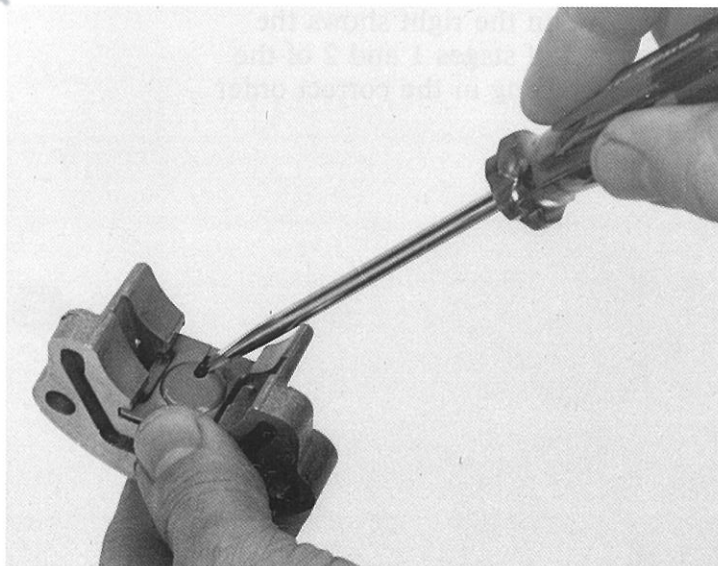

Secure the two governor housings, as illustrated here, to governor flange 33.010 with machine screws 33.100 and 33.104.

(Wrench size = TX 27 TORX insert.)

(Tightening torque = 10 Nm.)

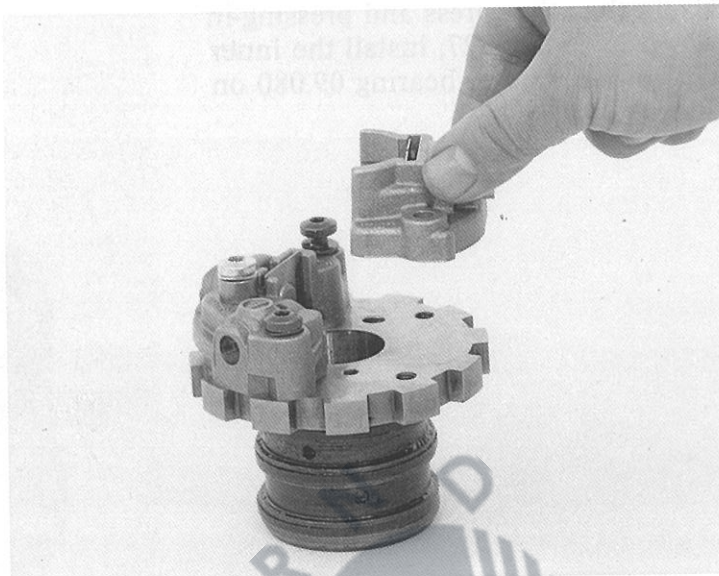

Install rectangular-section ring 33.020 at the start of the governor flange and hook it into position. Insert 2 „Pagu” rings 33.022 in the centre and rear ring grooves.

**Important:**

Do not stretch the „Pagu” rings more than is absolutely necessary to install them.



Turn the transmission housing through 180 degrees. Coat the rectangular-section and „Pagu” rings with grease (Vaseline) and insert the complete unit carefully into the transmission housing.

**Warning:**

Do not trap the „Pagu” rings. Work them into the ring groove if necessary with a blunt tool.

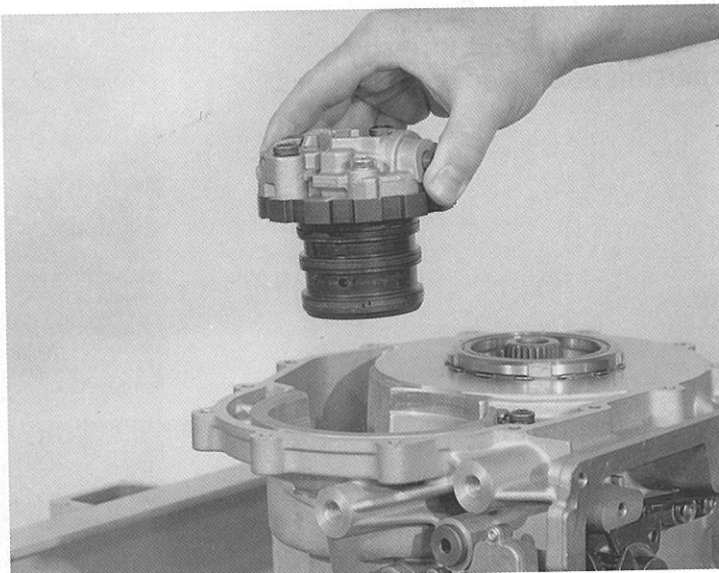



Using the arbor press and pressing-in ring 5 X 46 000 327, install the inner race of taper roller bearing 09.080 on side shaft 09.070.

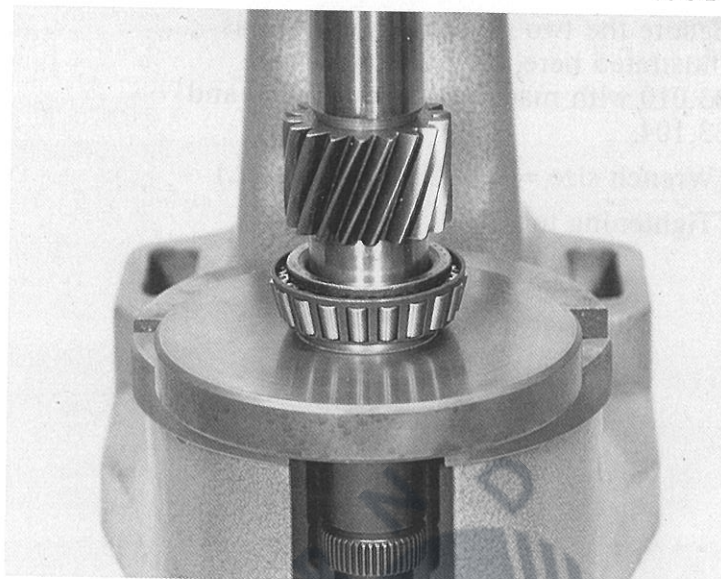

Turn the transmission through 90 degrees and insert the side shaft into the governor flange driving splines, turning it while doing so. Hold the governor flange to prevent it from falling out.

90079

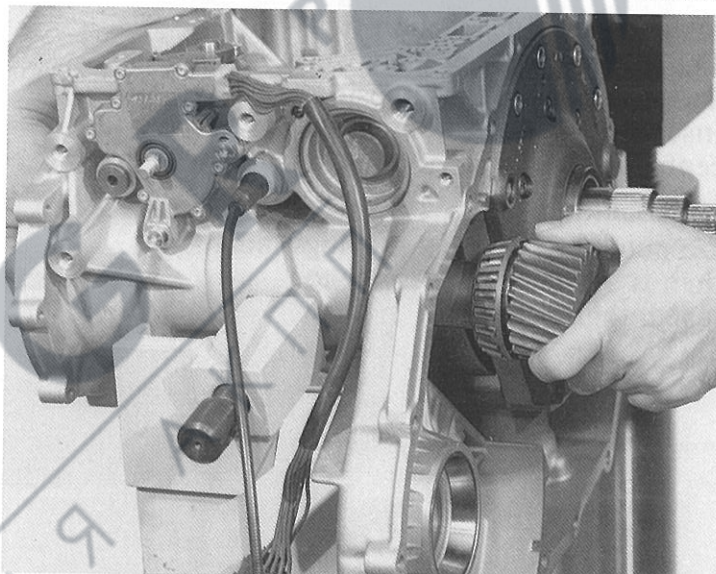

Bolt on retaining fixture 5 P 95 000 300 and turn the transmission through 90 degrees.

90080

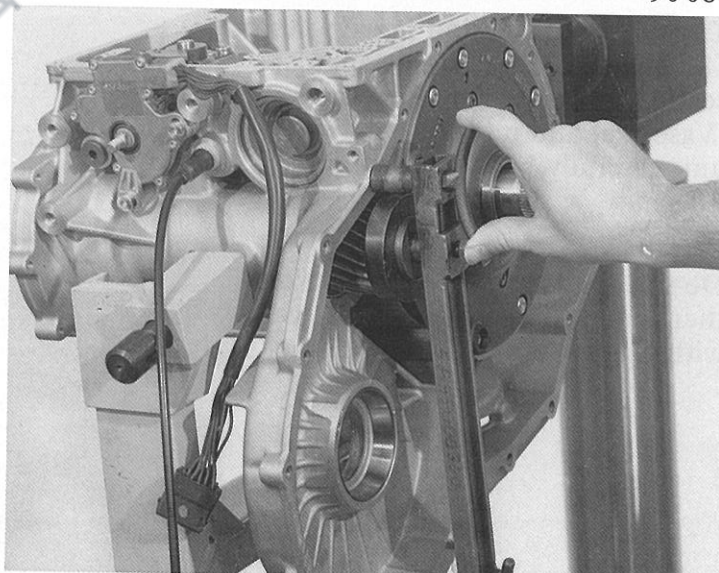



Install spacing sleeve 09.068 over the side shaft in the governor assembly.

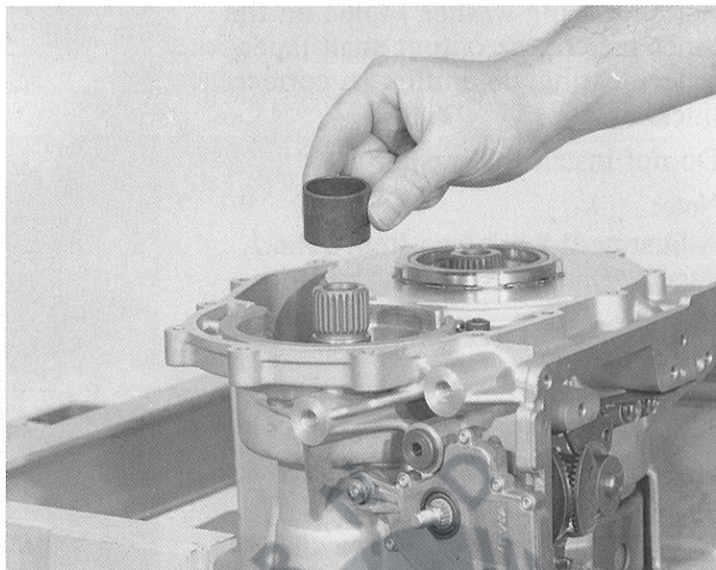

Heat the housing to app. 70°C with a hot air blower. Offer up the outer ring of taper roller bearing 09.040 and drive it fully in with a plastic-faced hammer.

**Warning:**

The outer race must be installed without play, to ensure that the measured setting is correct.

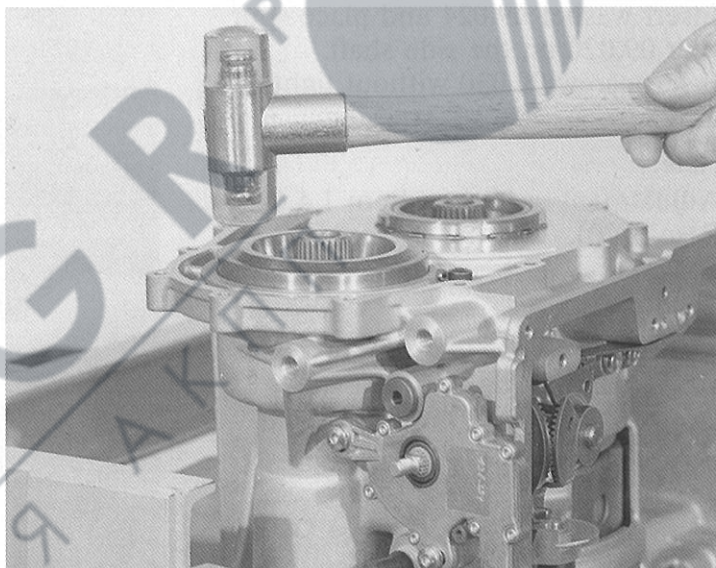

Using an arbor press with assembly sleeve 5 X 46 000 300, press the inner race of taper roller bearing 14.050 on to spur gear 09.010. Using assembly sleeve 5 X 46 000 174, press the inner race of taper roller bearing 09.040 on to spur gear 09.020.

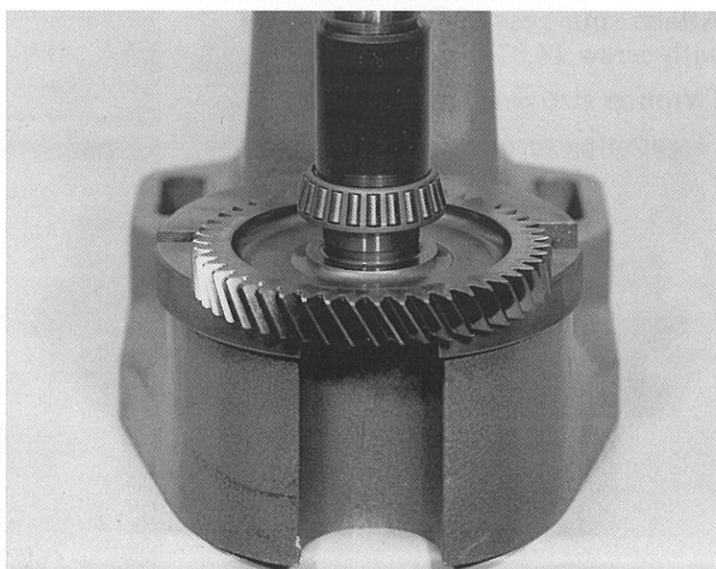



Before placing washer 14.064 on the inner race of the output shaft taper roller bearing, determine its correct thickness.

Do not install the washer yet.

**Note:**

Adjustment work (see Item 1.4.6.1, Page 5/7).

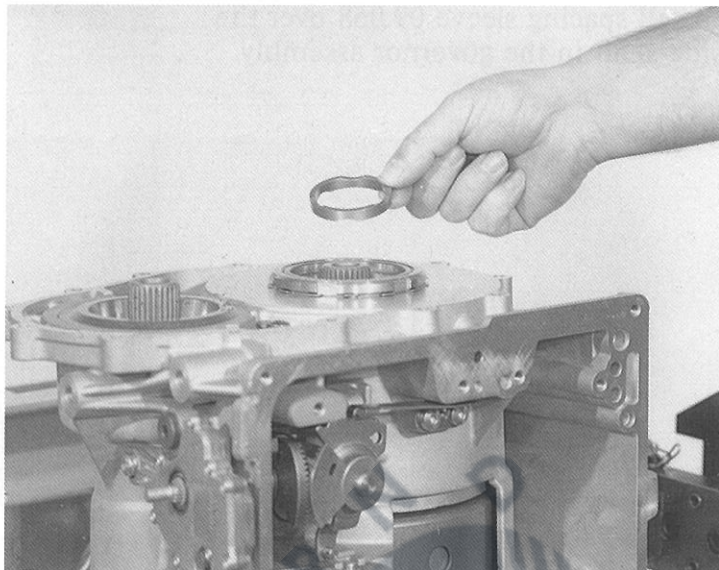

Insert washer 09.024 and place spur gear 09.020 on the side shaft.  
Insert screw 09.030 without tightening fully.

**Note:**

Adjustment work (see Item 1.4.6.2, Page 5/10).

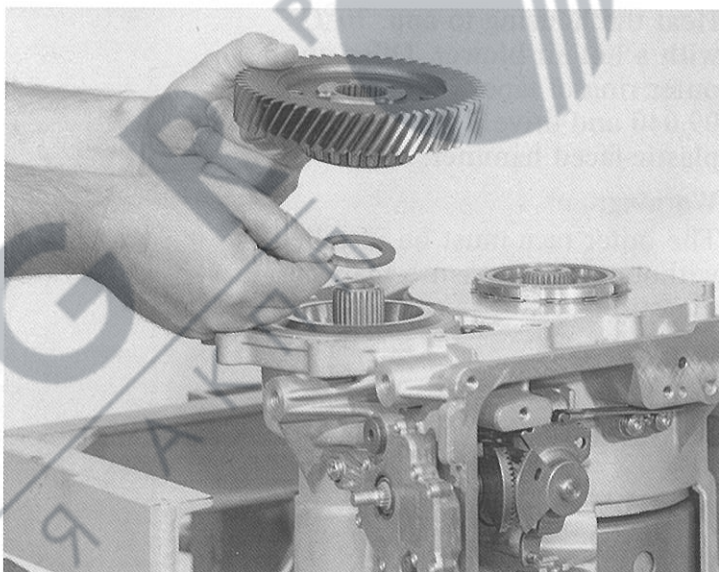

Attach spur gear 09.010 and secure with screw 14.070.

(Wrench size = 36 mm.)

(Tightening torque = 150 Nm.)

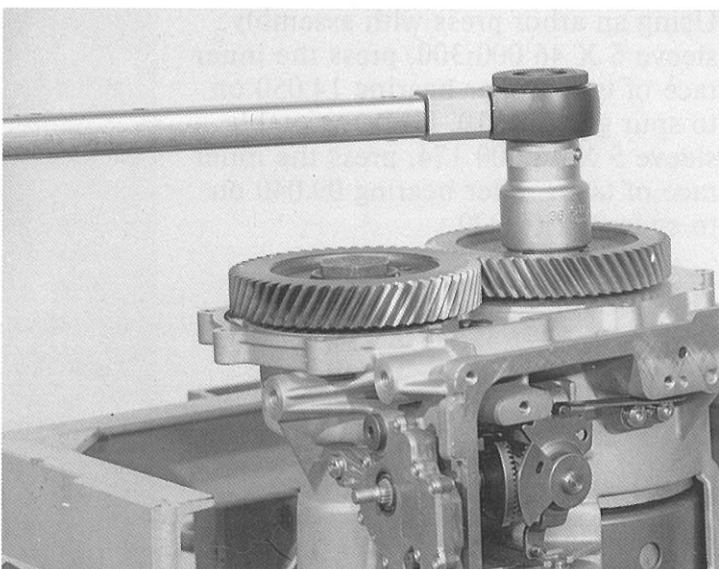



Punch-mark the two screws at two points on their circumference to retain them securely.  
Cover 09.300 and seal 09.290 with screws 09.310 and 09.314 are installed later.

In this connection, see Item 3.10 „Differential, input shaft and bell housing”, Page 102.

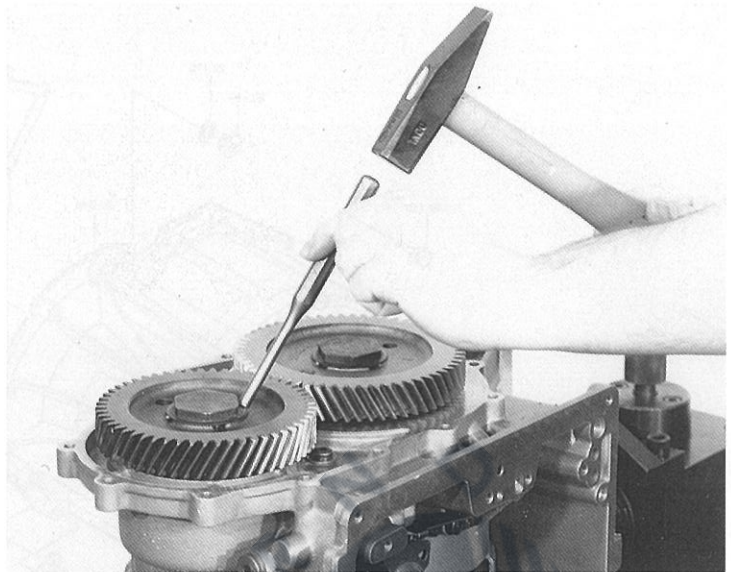

90075

Turn the transmission through 180 degrees and make sure that the brake C cup spring is in contact with the housing (it should yield when pressure is applied to the pump housing).

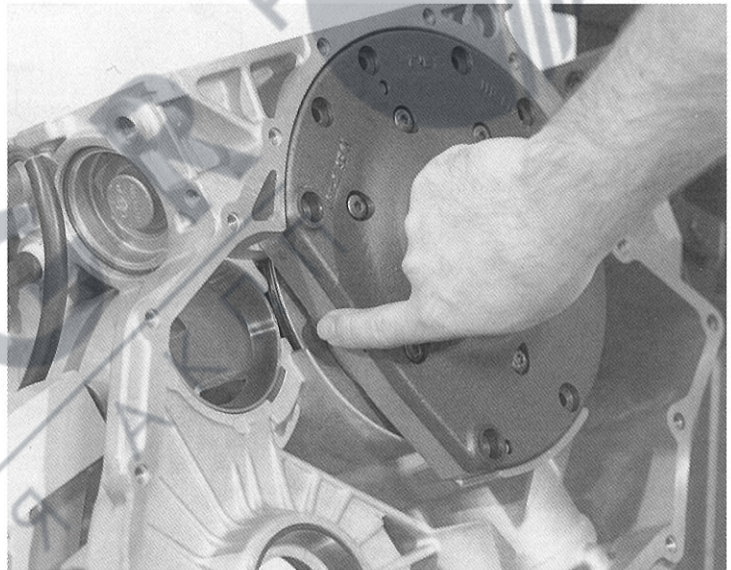

90077

The pump/intermediate plate can now be tightened down firmly.

(Wrench size = TX 27 TORX insert.)

(Tightening torque = 10 Nm.)

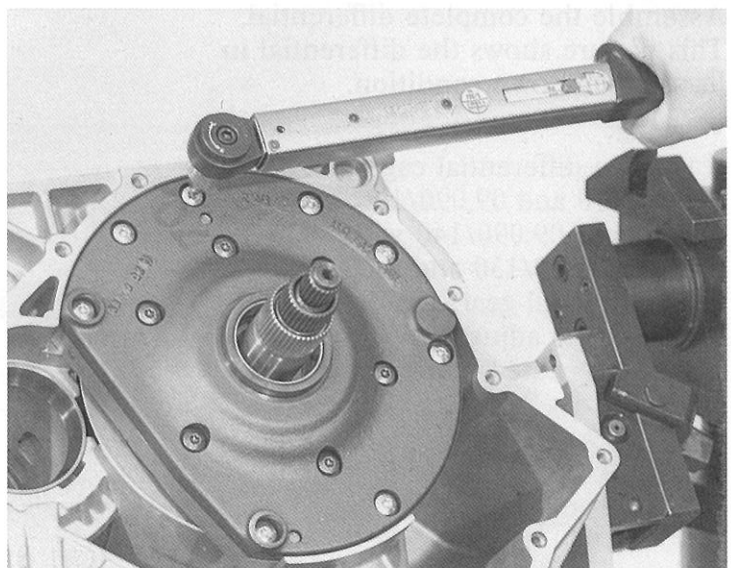



### 3.10 Differential and bell housing with extension (speedometer)

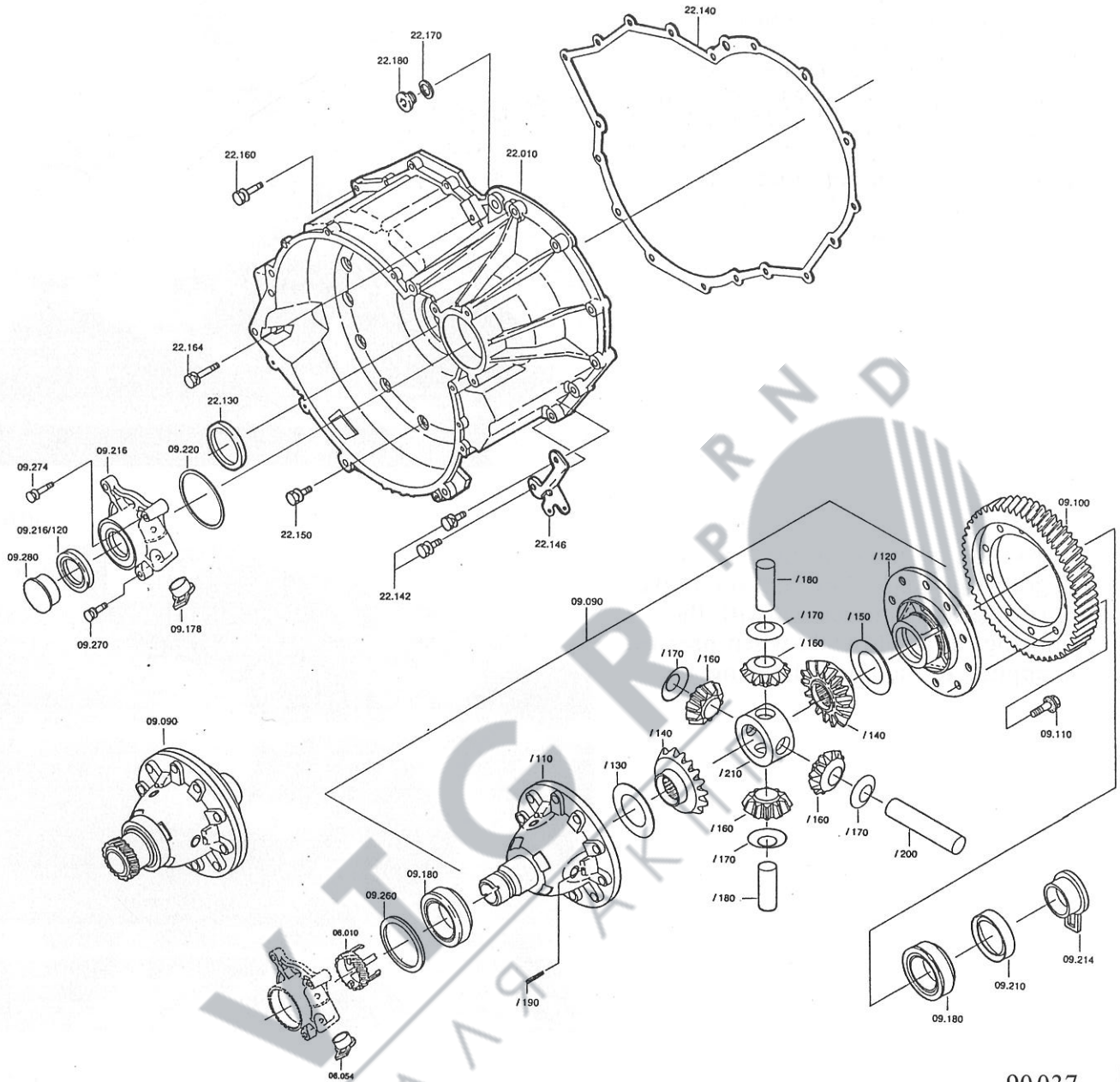

90037

Assemble the complete differential. This picture shows the differential in its stripped-down condition.

**Warning:**

If the two differential cages 09.090/110 and 09.090/120, the two bevel gears 09.090/140 with shim washer 09.090/130 and 09.090/150 and the differential gears 09.090/160 are renewed, the adjustment procedure must be repeated.

(See Item 1.4.11, Page 5/17.)

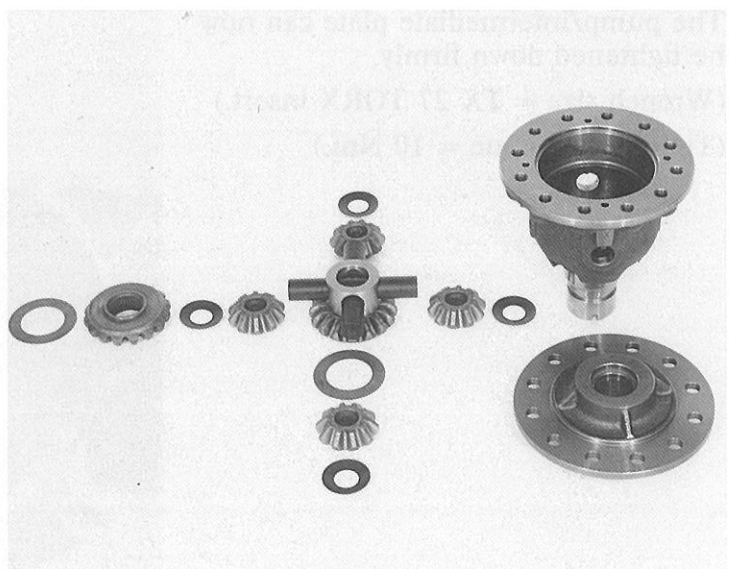

90092

Remove fixture 5 P 95 000 300.

**Warning:**

For production engineering reasons, only the complete unit can be exchanged on differentials with a steel speedometer drive worm (because this is a safety component).

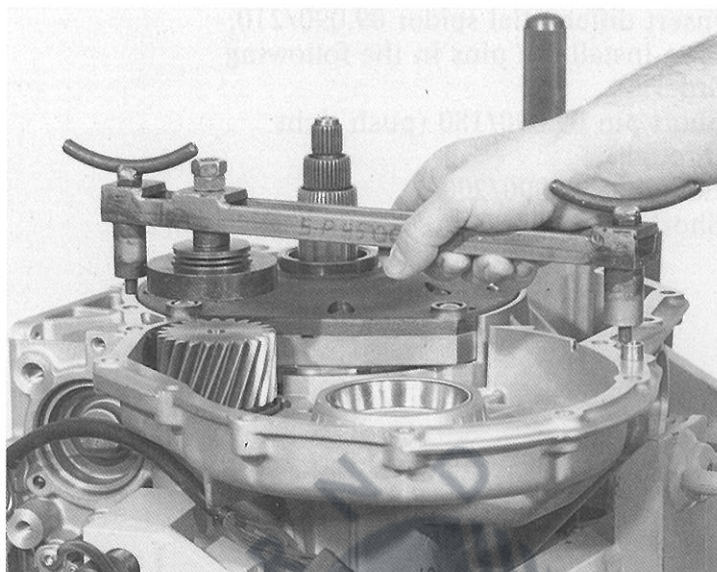

90093

Insert the unmarked shim washer 09.090/130 and bevel gear 09.090/140 into differential cage 09.090/110.

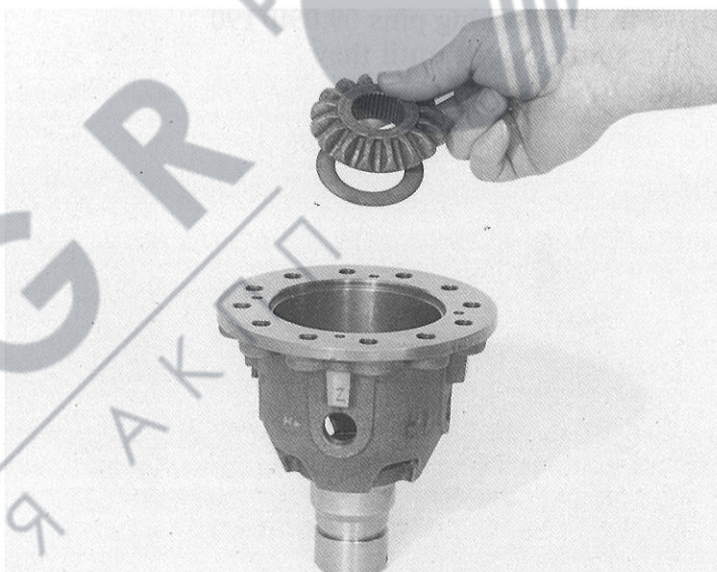

90094

Place the four differential gears 09.090/160 with thrust washers 09.090/170 in the cage.

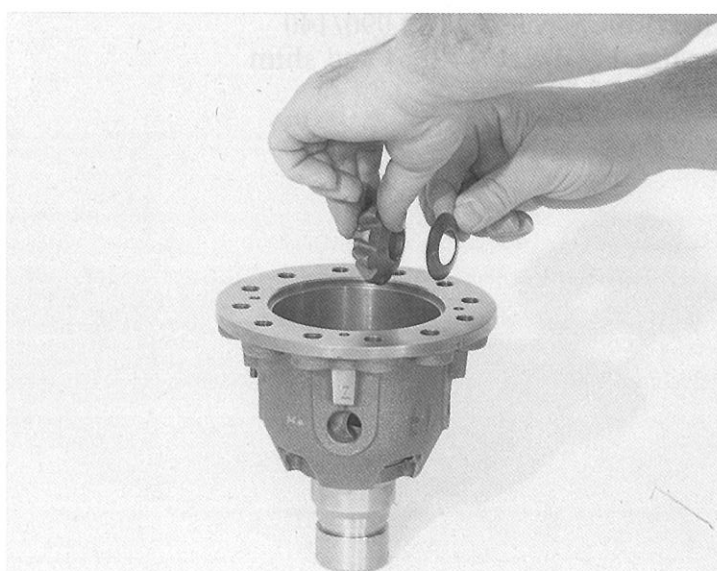



90095

Insert differential spider 09.090/210,  
then install the pins in the following  
order:

Short pin 09.090/180 (push right  
through)

Long pin 09.090/200

Short pin 09.090/180.

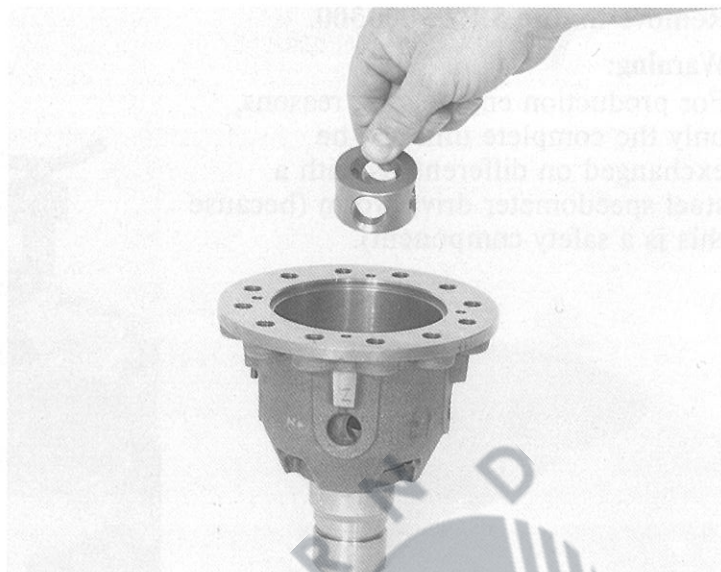

Drive in new locking pins 09.090/190  
with a suitbale drift until they  
project by 13.0 – 14.0 mm.

90096

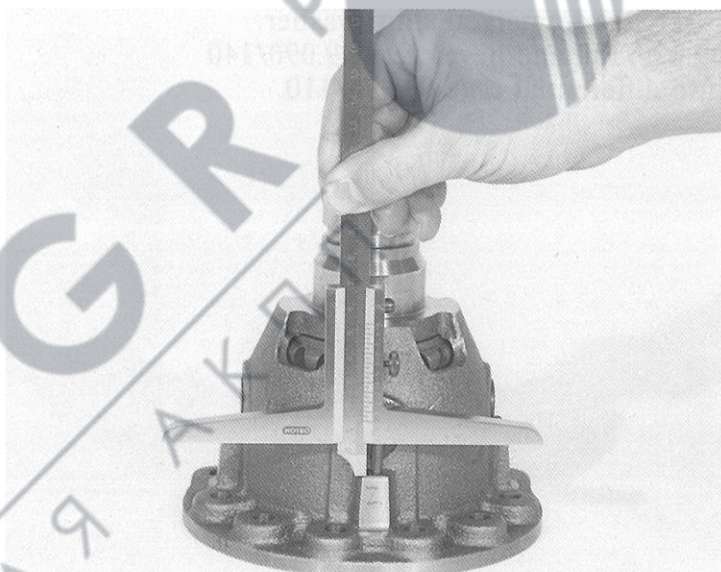

Insert the bevel gear 09.090/140  
(marked „OBEN“ = top) and shim  
washer 09.090/150.

90097

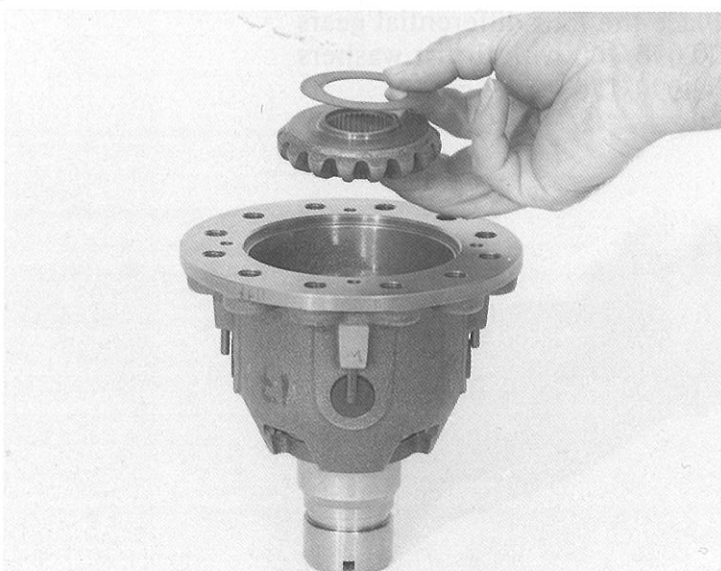

Align differential cage 09.090/120 (upper section) on the lower section, and place it in position.

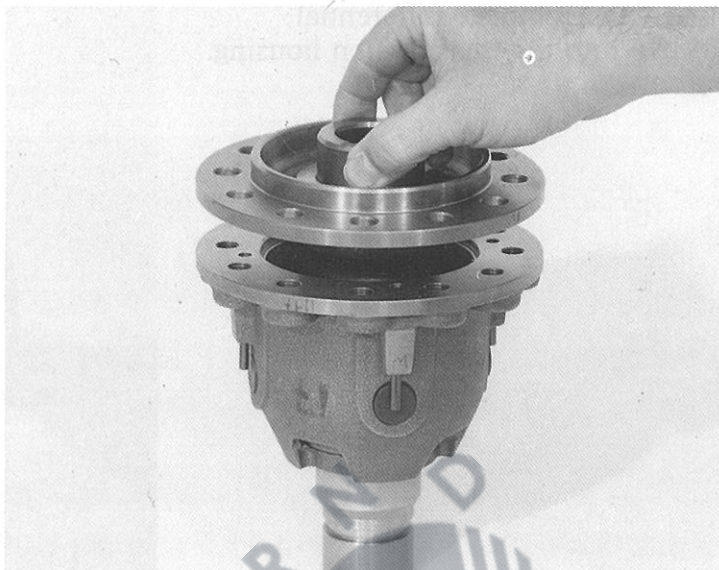

Clamp the differential into the vice and secure spur gear 09.100 with 12 locking screws 09.110.

(Wrench size = 17 mm.)

(Tightening torque = 77 Nm.)

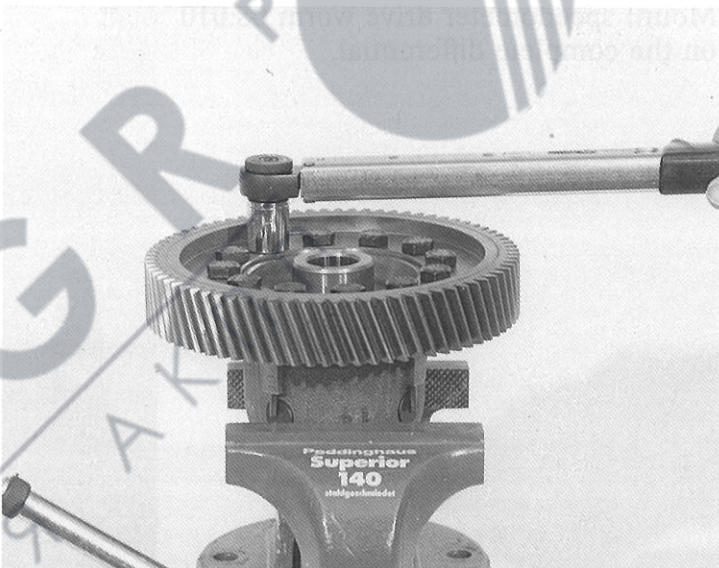

Press on both inner taper roller bearing races for bearings 09.180 in the arbor press, using a suitable sleeve, for example 5 X 46 000 742.

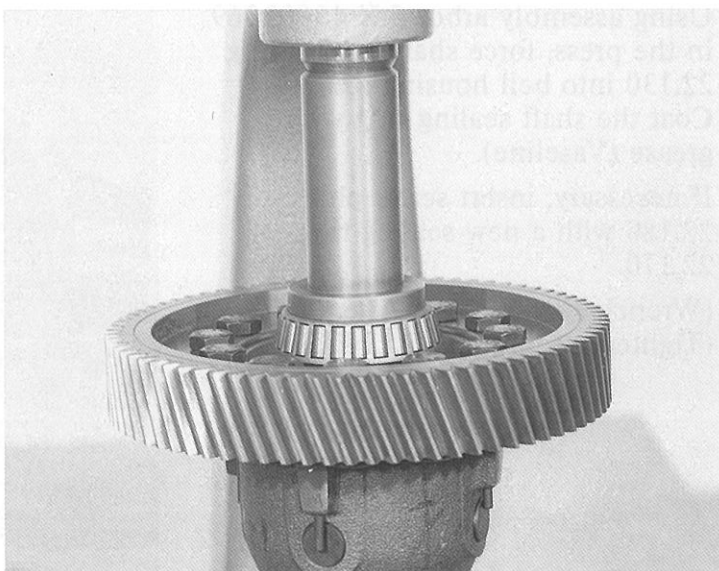



Insert the complete differential  
09.090 into the transmission housing.

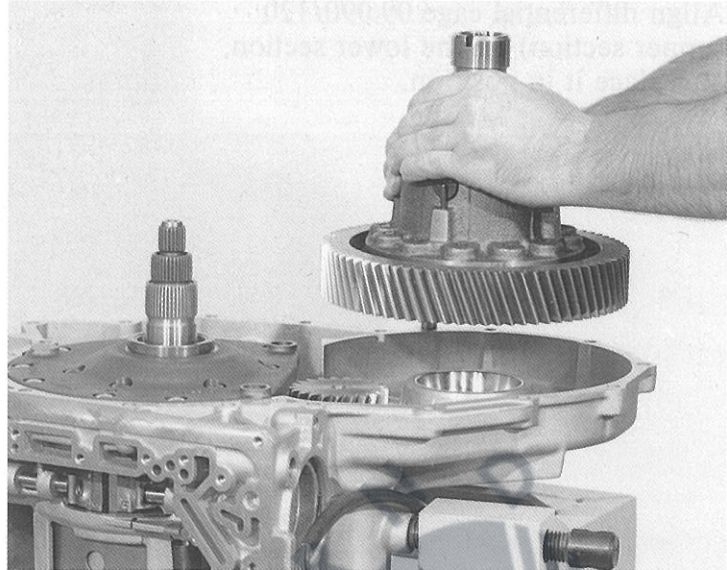

Mount speedometer drive worm 08.010  
on the complete differential.

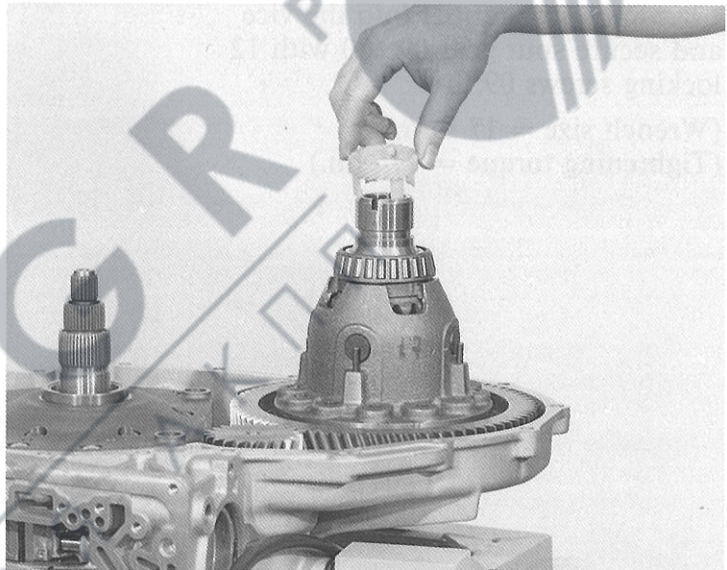

Using assembly arbor 5 X 46000369  
in the press, force shaft sealing ring  
22.130 into bell housing 22.010-  
Coat the shaft sealing ring with  
grease (Vaseline).

If necessary, insert screw plug  
22.180 with a new sealing ring  
22.170.

(Wrench size = 8 mm Allen key.)  
(Tightening torque = 45 Nm.)

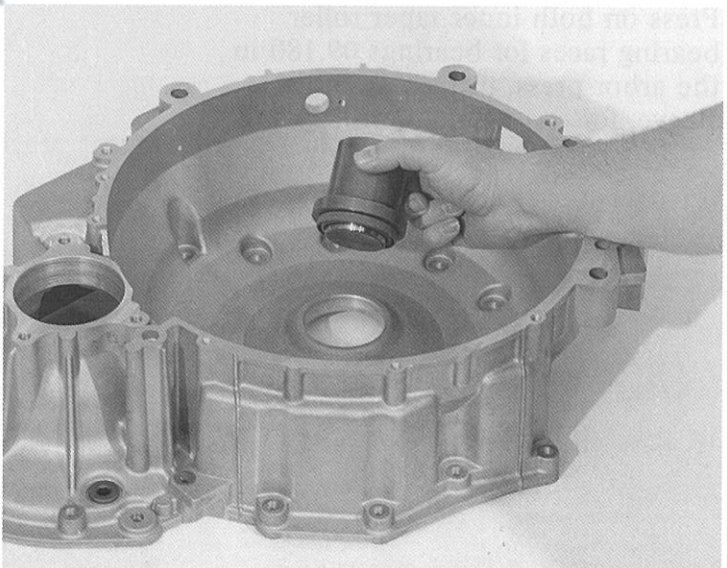



Attach seal 22.140 temporarily with grease (Vaseline) and align it.

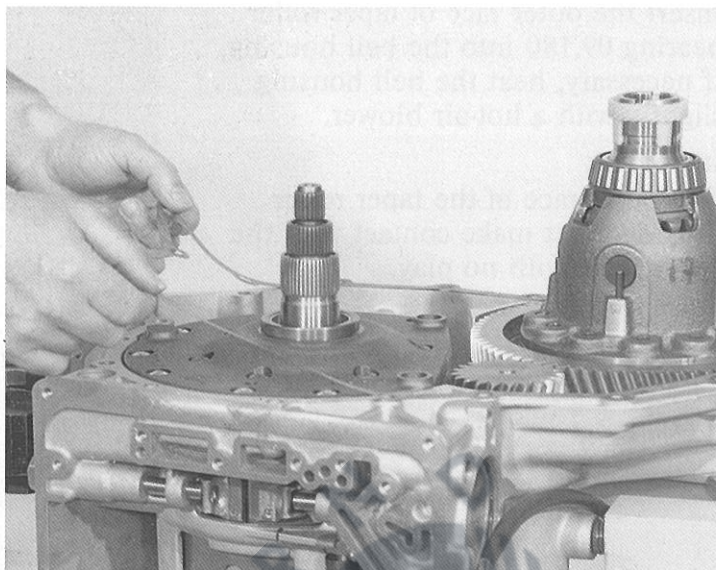

Attach the bell housing and secure it with the 18 hex bolts  
(Wrench size = 13 mm.)  
(Tightening torque = 23 Nm.)  
Insert screws 22.142 to secure retaining plate 22.146.

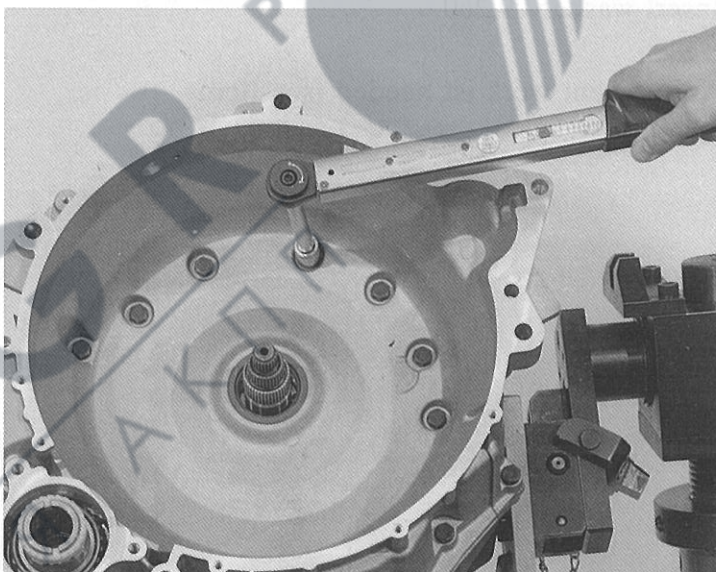

Bolts for bell housing:

Item	Qty.	Dimensions	Note
-a 22.142	2	M8x45	with retaining plate 22.146
-b 22.150	6	M8x25	
-c 22.160	9	M8x42	
-d 22.164	1	M8x50	

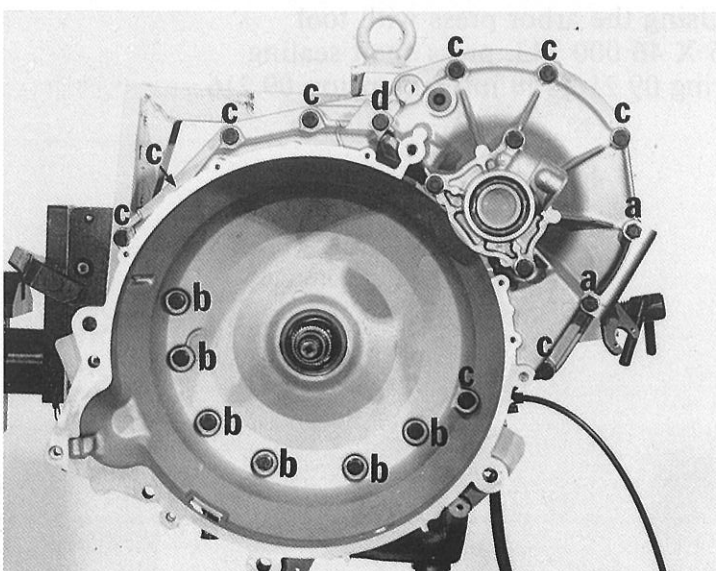



Insert the outer race of taper roller bearing 09.180 into the bell housing. If necessary, heat the bell housing slightly with a hot-air blower.

**Important:**

The outer race of the taper roller bearing must make contact with the inner race, with no play.

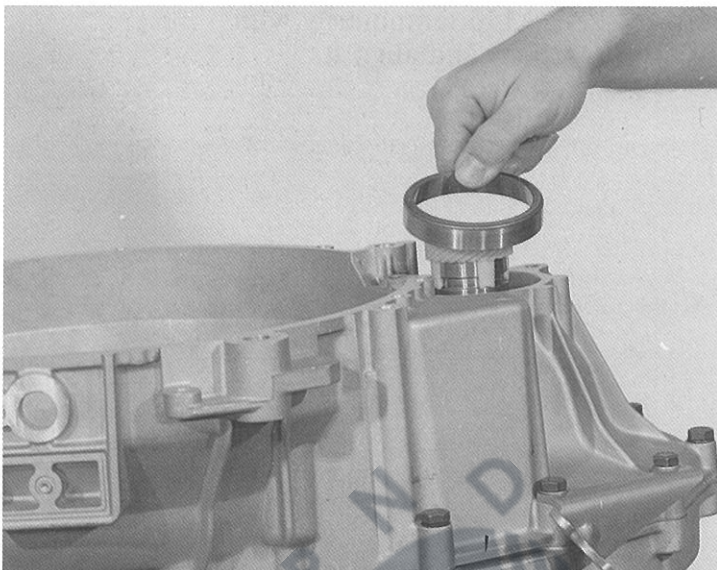

Insert washer 09.260.

**Note:**

Adjustment work is needed (see Item 1.4.7, Page 5/13).



Using the arbor press with tool 5 X 46 000 743, press shaft sealing ring 09.216/120 into extension 09.216.

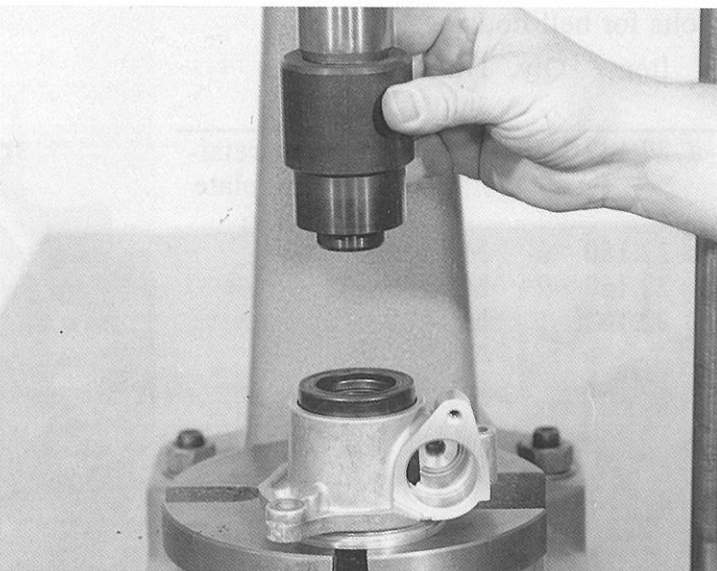

Pull on the O-ring 09.200 and coat it lightly with grease (Vaseline).



Insert the complete extension and attach it to the bell housing with 2 hex bolts 09.270 and 1 hex bolt 09.274.

(Wrench size = 13 mm.)

(Tightening torque = 23 Nm.)

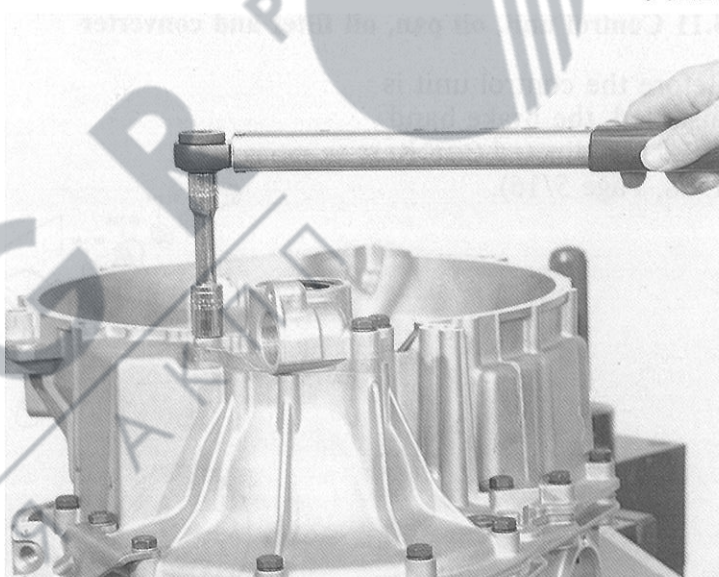

Press shaft sealing ring 09.210 into the housing with tool 5 X 46 000 744.

You are recommended to install end caps 09.178 (08.054), 09.214 and 09.280 for protection in transit.

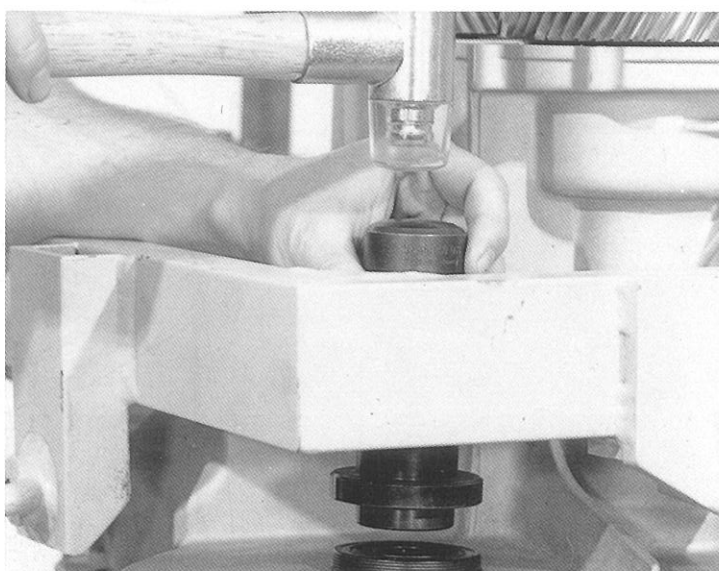



Cover 09.300 for the spur gear drive can now be installed.  
First attach gasket 09.290 with grease (Vaseline) and align it, then secure the cover in position with the 13 machine screws 09.310.

(Wrench size = TX 27 TORX insert.)  
(Tightening torque = 10 Nm.)

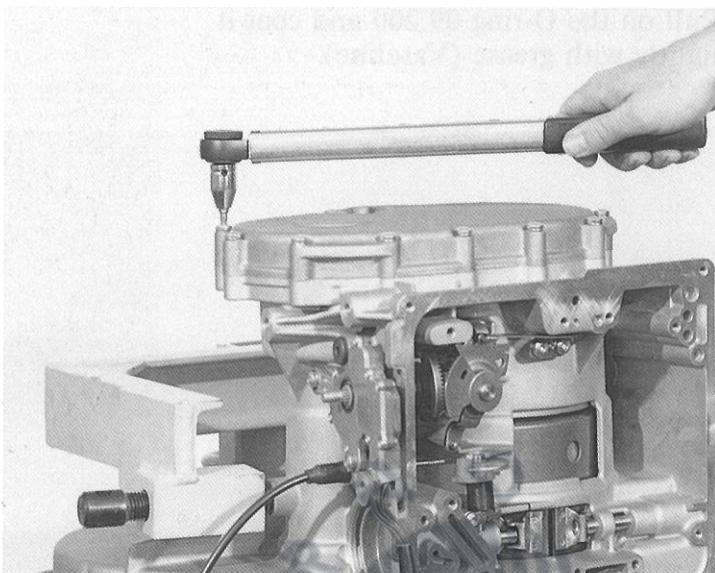

### 3.11 Control unit, oil pan, oil filter and converter

Before the control unit is installed, the brake band must be adjusted (see Item 1.4.8, Page 5/16).

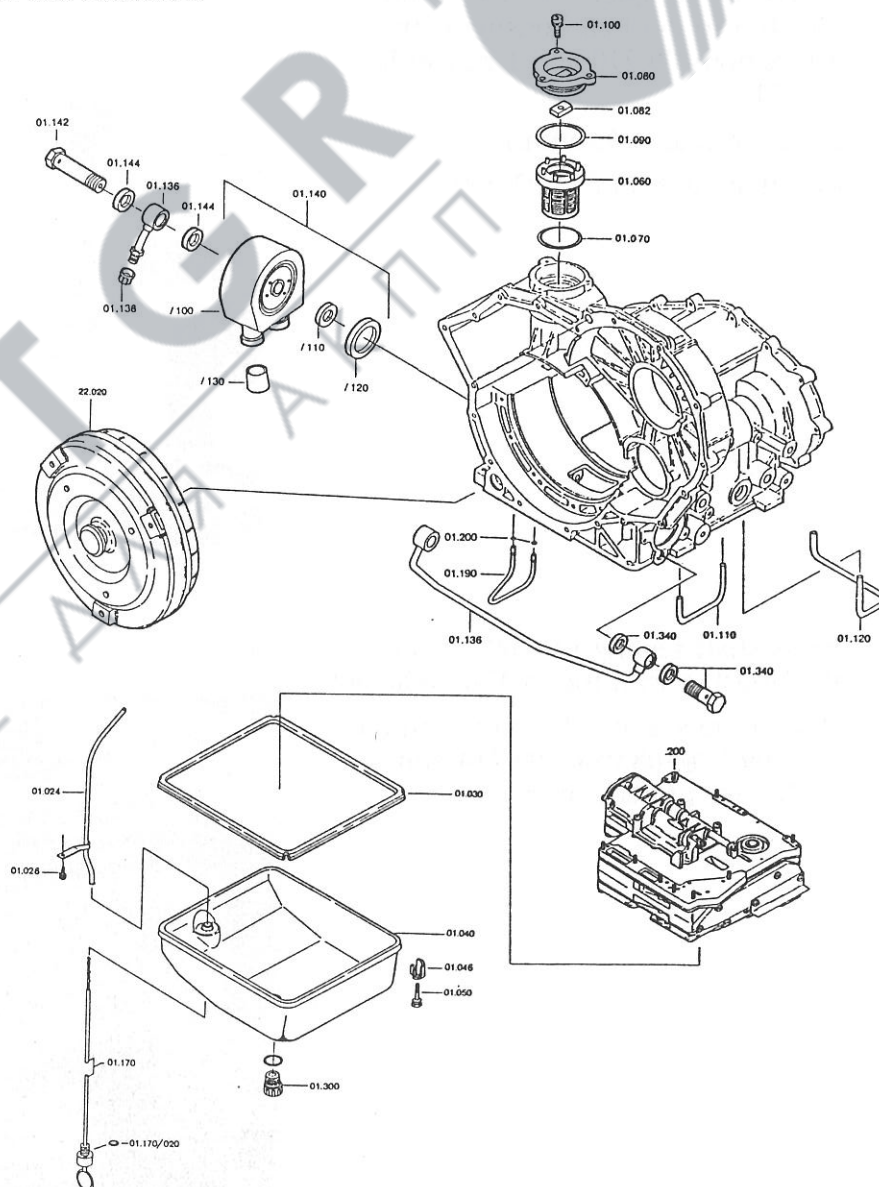

Insert oil pipe 01.110 into pressing-in tool 5 X 46 000 279 and drive in fully with a plastic-faced hammer.

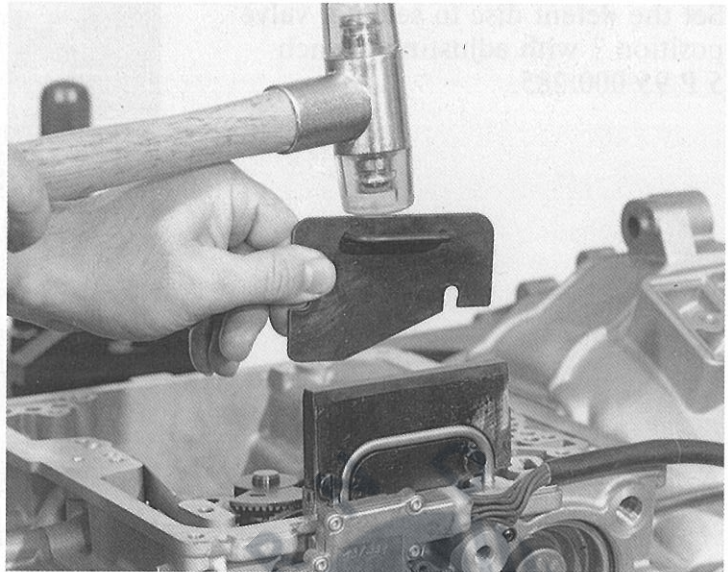

Insert oil pipe 01.120 in installing tool 5 X 46 000 280 and drive fully in with a plastic-faced hammer.

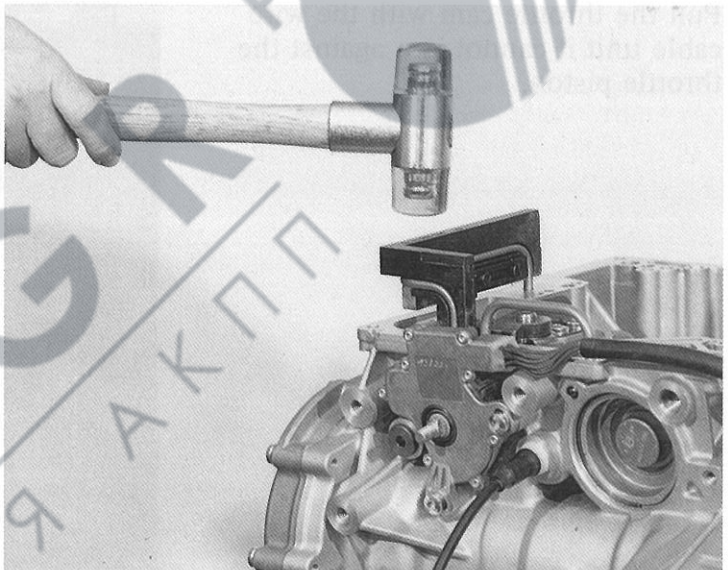

Secure pipe 01.024 with machine screw 01.026 in the position illustrated here.

(Wrench size = TX 27 TORX insert.)  
(Tightening torque = 5 Nm.)

**Warning:**

Turn the housing through 90 degrees to prevent the machine screw from falling inside.

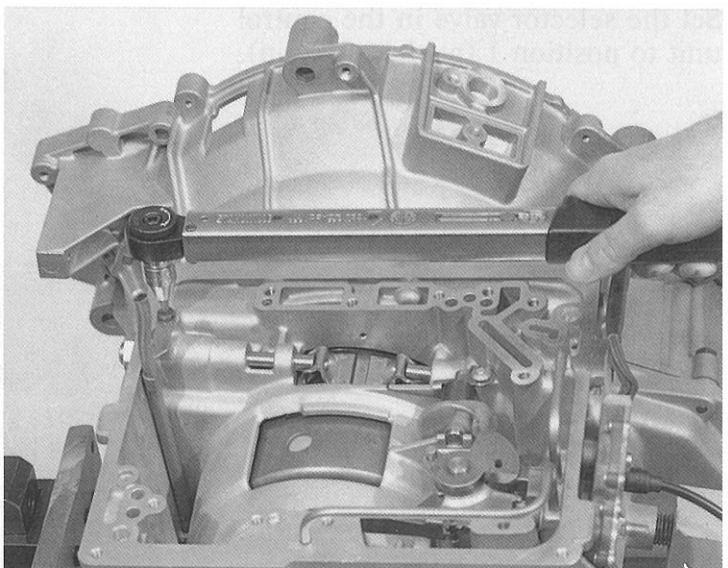



90133

Set the detent disc to selector valve position 1 with adjusting wrench 5 P 95 000 285.

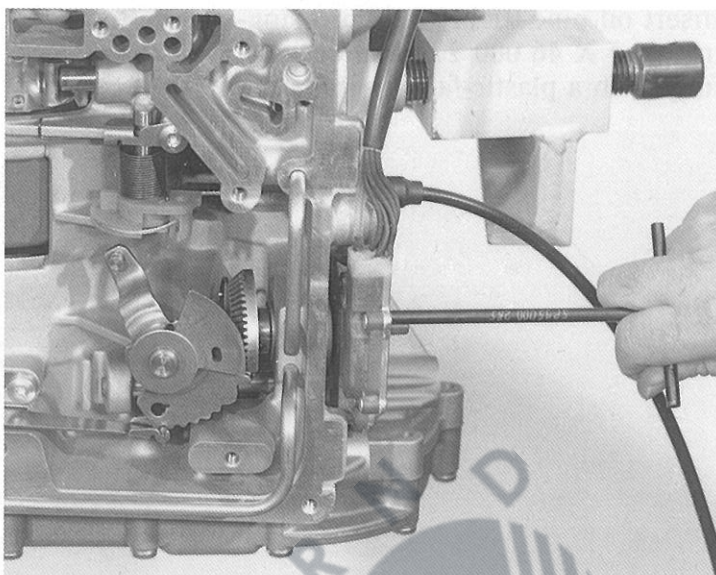

90134

Pull the throttle cam with the wire cable unit it cannot jam against the throttle piston.

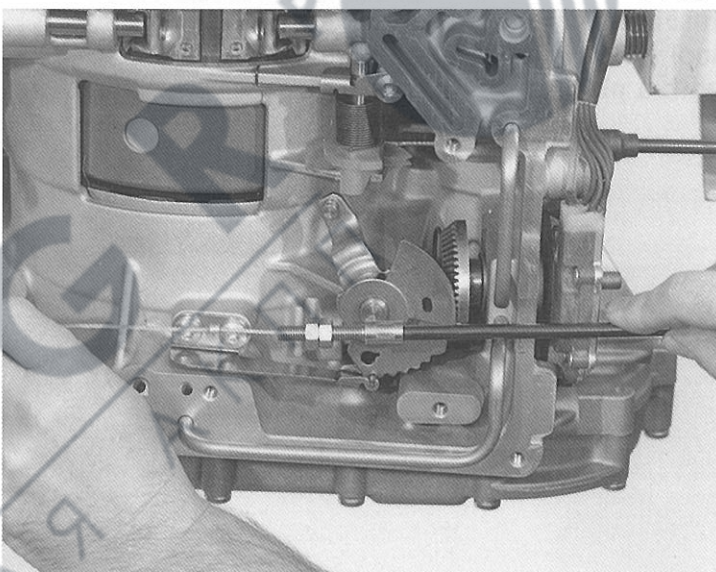

89054

Set the selector valve in the control unit to position 1 (pushed fully in).

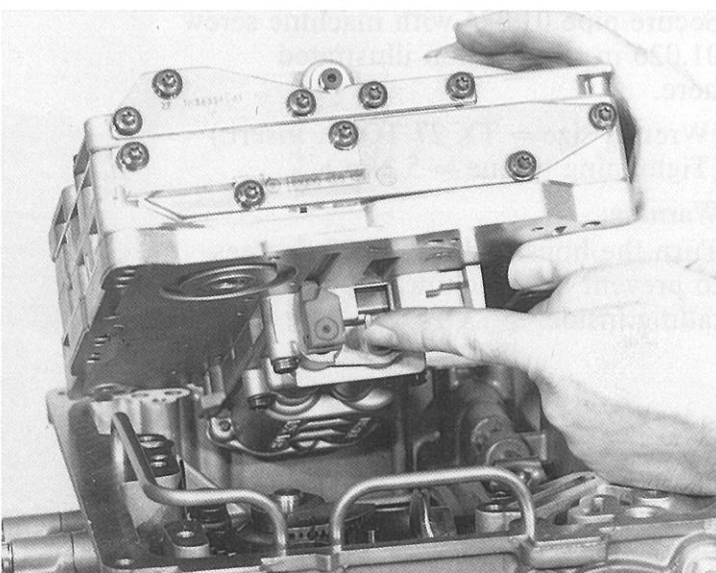

Attach control unit 200 (throttle cable pulled). Make sure that the selector valve is connected to the pin of the detent disc.

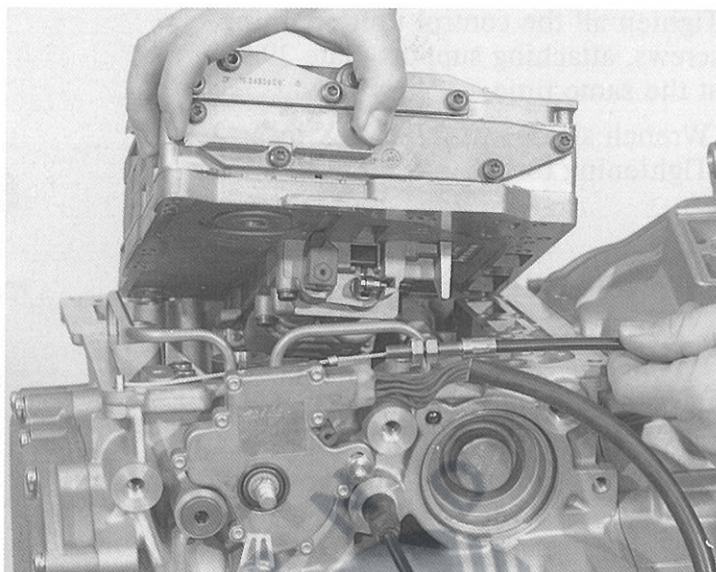

Attach the control unit with the following machine screws:

Item	Quantity	Thread	Length
310	1	M 6	35 mm
970	8	M 6	75 mm
974	1	M 6	70 mm

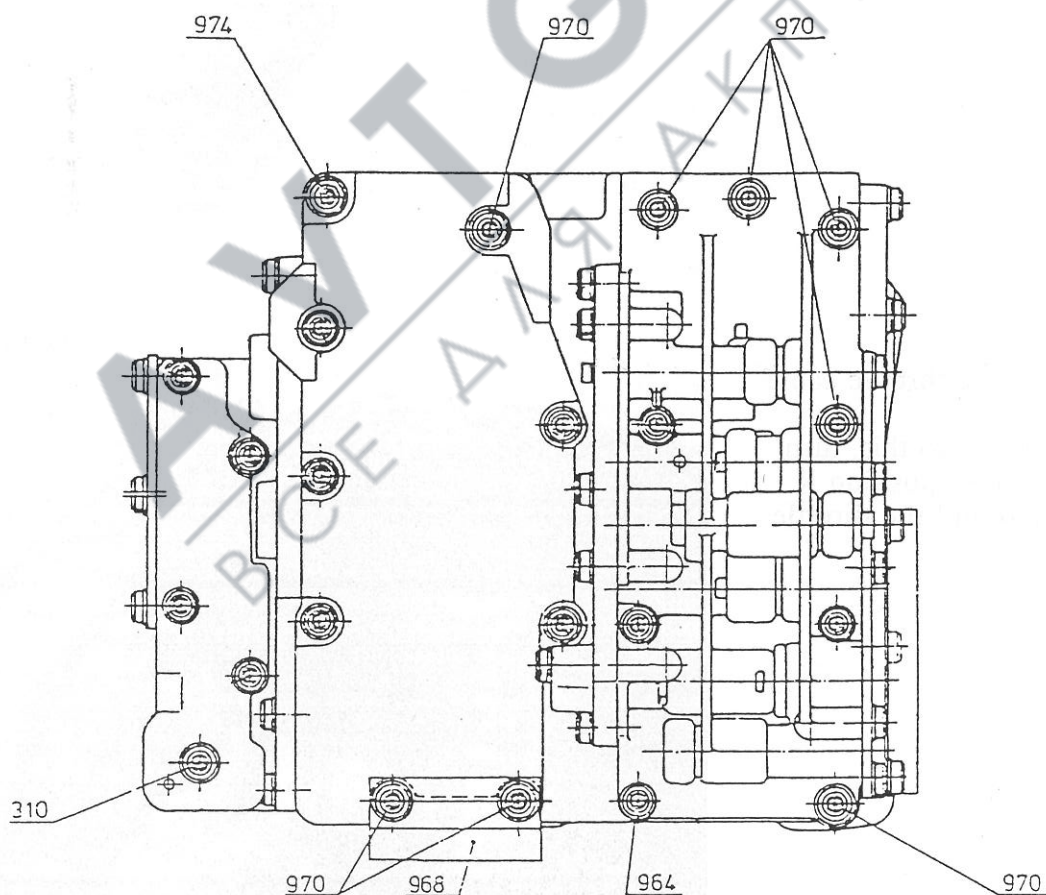



Tighten all the control unit retaining screws, attaching support plate 29.968 at the same time.

(Wrench size = TX 27 TORX insert.)  
(Tightening torque = 8 Nm.)

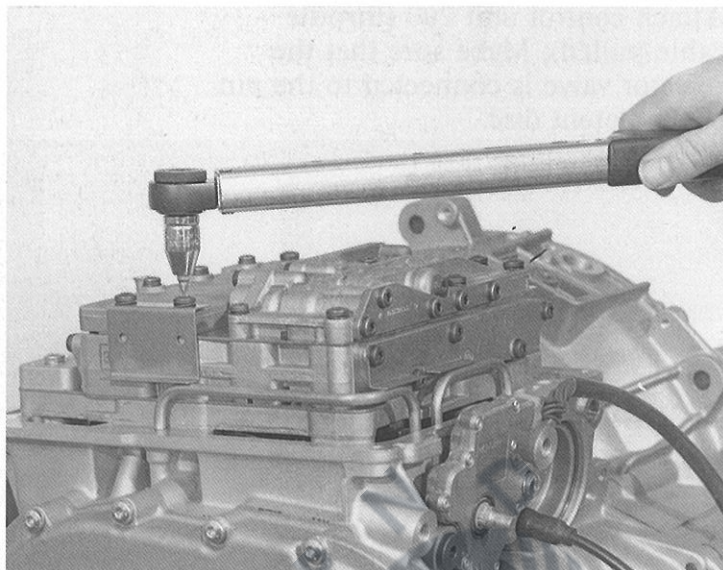

**Note:**

You are recommended to adjust the throttle cable immediately after this and secure it with a lead seal.

This will prevent it from becoming disconnected at the throttle cam.

(See Item 1.4.9, Page 5/17.)



Check operation of the throttle cable and shift.

Check all positions: to do this, turn the adjusting wrench to position R (anti-clockwise) and pull the throttle cable.

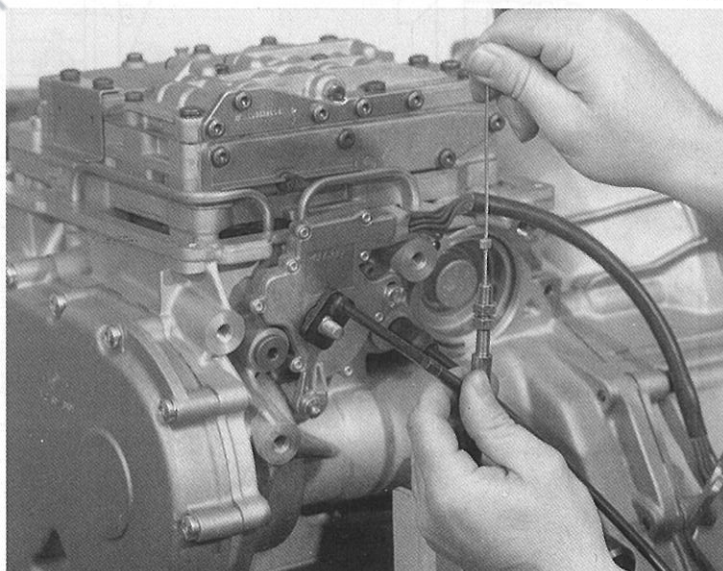



On the turbocharged version, install a new pipe 01.190 for boost pressure feed, with two new O-rings 01.200. Insert the pipe in installation tool 5 X 46 000 352 and drive it fully in with a plastic-faced hammer.

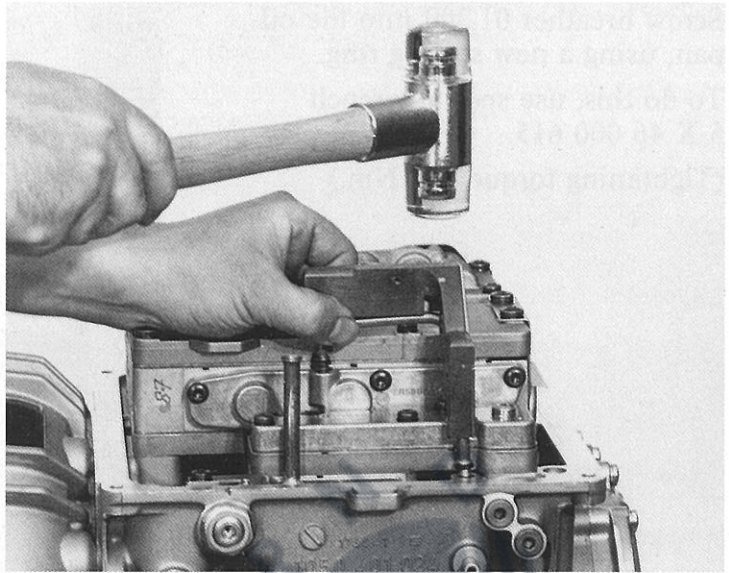

Attach seal 01.130 to the edge of oil pan 01.040.

90 138

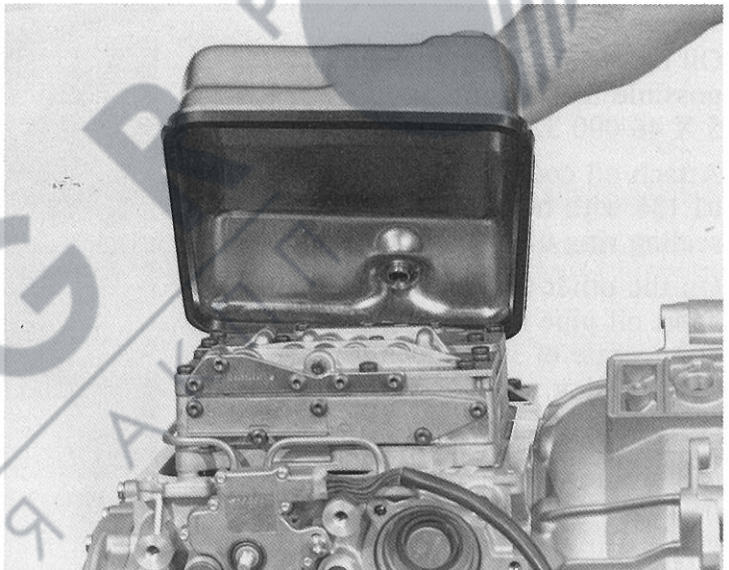

Attach the oil pan, using four retaining plates 01.046 and four hex bolts 01.050.

(Wrench size = 10 mm.)  
(Tightening torque = 6 Nm.)

90 139

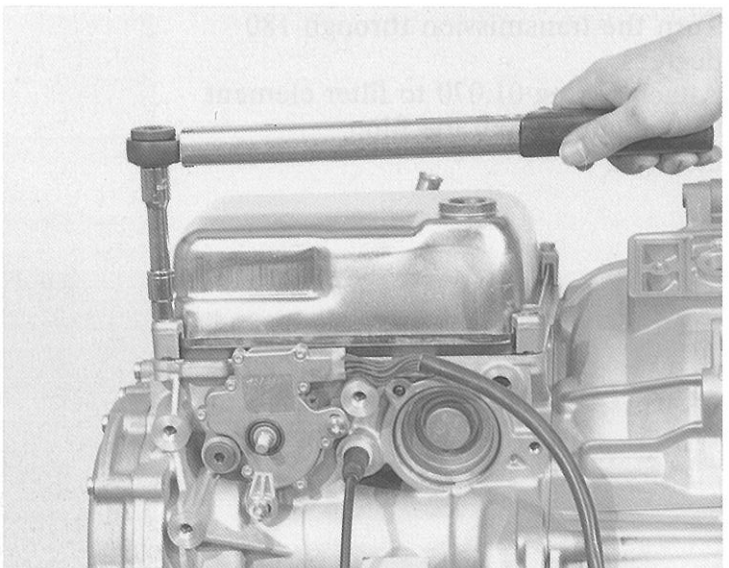



Screw breather 01.300 into the oil pan, using a new sealing ring.

To do this, use special wrench 5 X 46 000 615.

(Tightening torque = 5 Nm.)

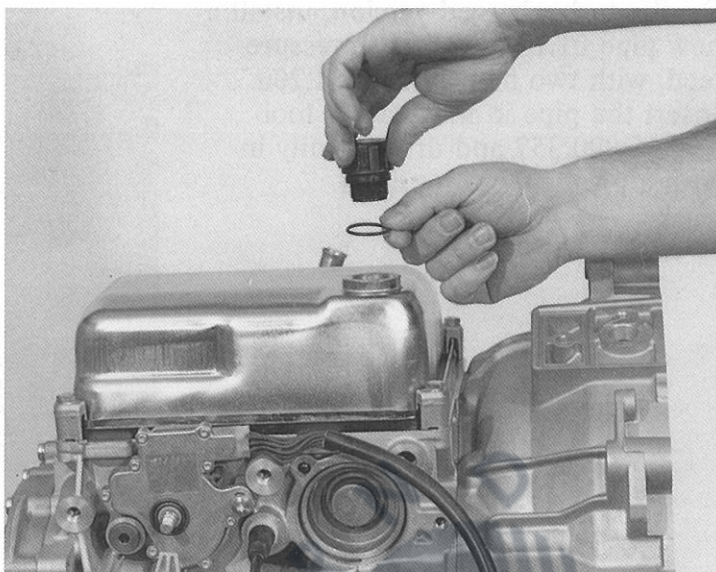

**Warning:**

Oil cooler assembly may not be possible until clamp hoop 5 X 46 000 329 has been removed.

Attach oil cooler 01.140 and oil pipe 01.136 with hollow screws 01.142 (with sealing ring 01.144 and 01.340).

On the other version, ensure that the short oil pipe is correctly positioned at an angle of 30 degrees to the bell housing when assembled.

(Wrench size = 27/19 mm.)

(Tightening torque for Item 01.142 = 60 Nm.)

(Tightening torque for Item 01.340 = 50 Nm.)

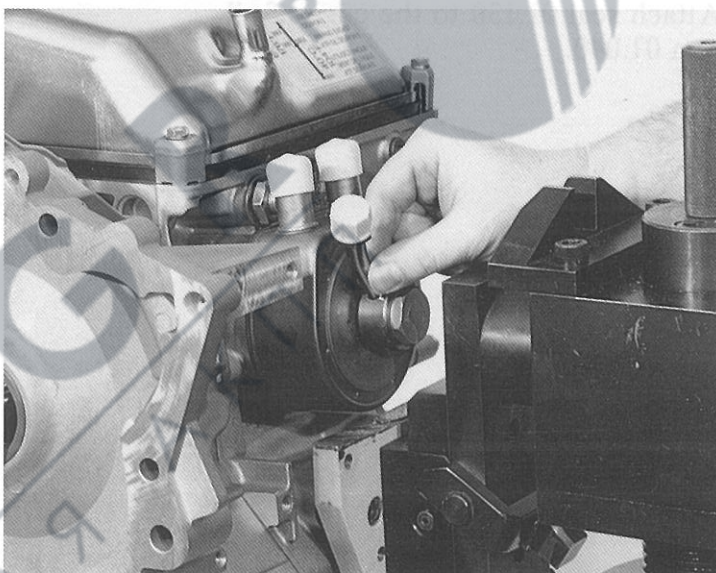

Turn the transmission through 180 degrees.

Attach O-ring 01.070 to filter element 01.060, and install the filter element.

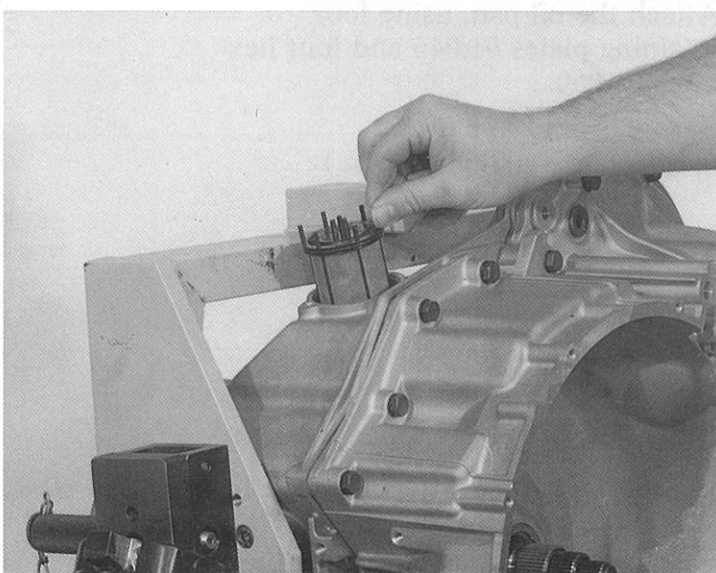



Pull O-ring 01.090 on to cover 01.080 and attach magnet 01.082 with grease (Vaseline).

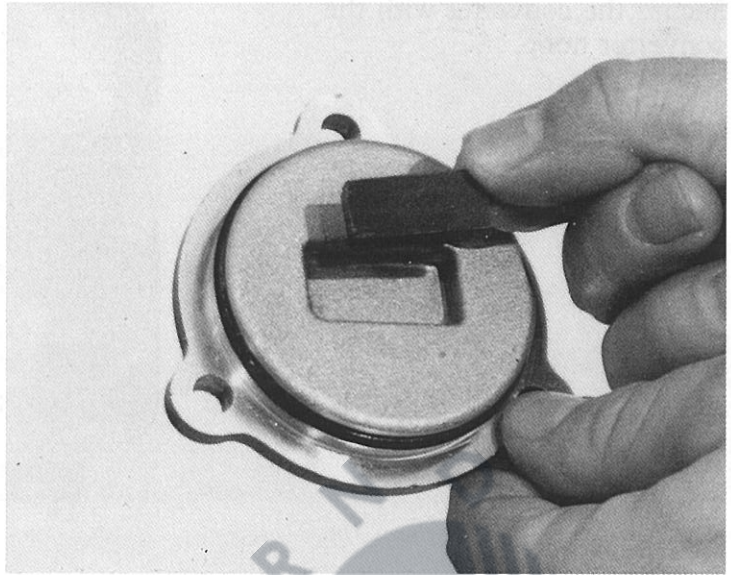

90 143

Attach the cover with 3 machine screws 01.100 and tighten the screws.

(Wrench size = TX 27 TORX insert.)  
(Tightening torque = 8 Nm.)

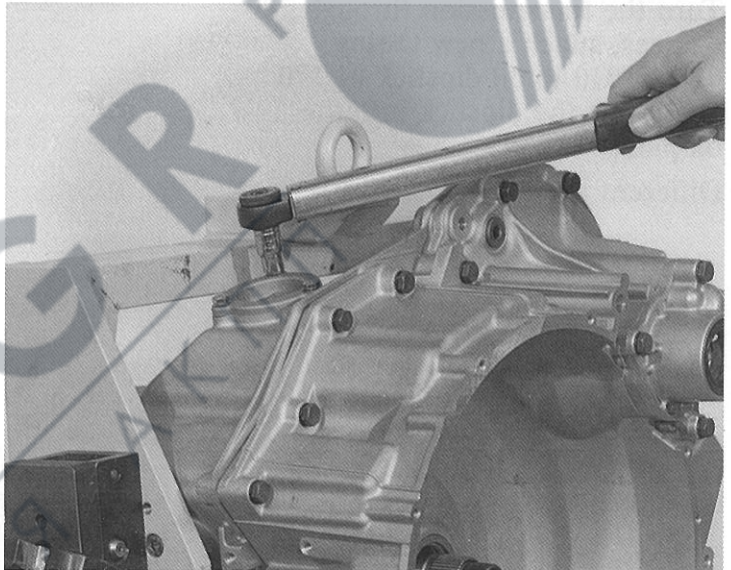

90 144

Insert converter 22.020 as far as possible, using two handles 5 X 56 000 110, and turning it at the same time.

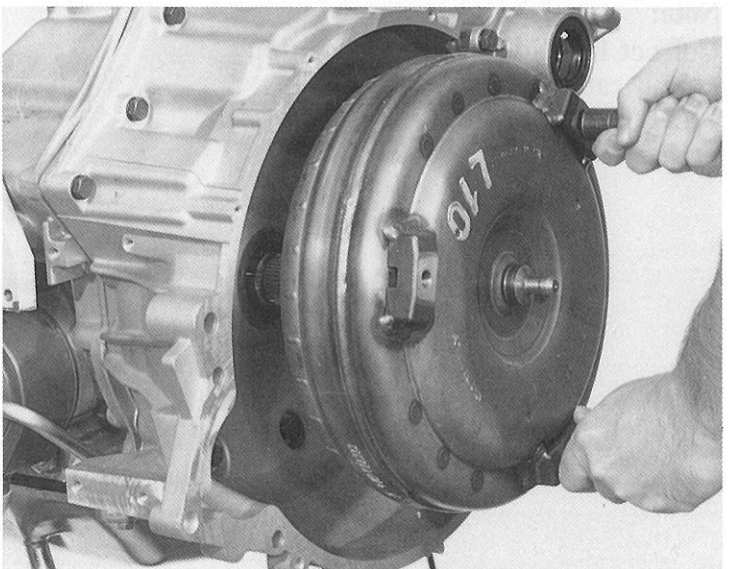



90145

Secure the converter with the converter hoop.

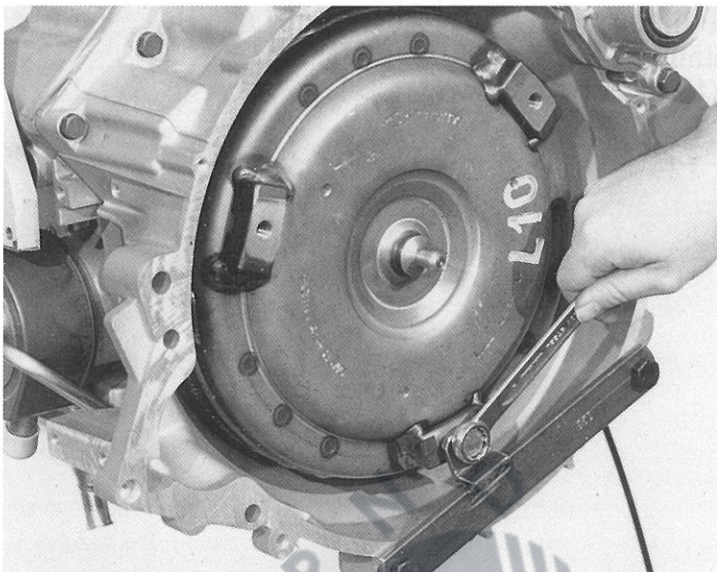

90146

Turn the transmission through 180 degrees, attach a new O-ring 01.170/010 to oil dipstick 01.170 and insert the dipstick into the oil pan.

Different versions are possible.



90147

**Note:**

Correct functioning of the position switch can be checked (see Item 1.4.10, Page 5/17).

