

REPAIR MANUAL



4 HP 18



ZF GETRIEBE GMBH SAARBRÜCKEN

CONTENTS

	Page
Preinformation	1
1. General	2
1.1 Illustration of transmission	2
1.2 Power flow	2
1.3 Lubrication	3
1.4 Adjustments	5/1
1.4.1 Clearance of shaft selector mechanism (washer)	5/1
1.4.2 Release clearance of brake D (snap ring)	5/2
1.4.3 Release clearance of clutch A (snap ring)	5/3
1.4.4 Release clearance of brake C (snap ring)	5/4
1.4.5 Axial clearance (washer)	5/5
1.4.6 Spur gear drive	5/7
1.4.6.1 Preload of output shaft (washer)	5/7
– Method A	5/7
– Method B	5/10
1.4.6.2 Clearance of counter shaft (washer)	5/13
1.4.7 Preload of differential (washer)	5/16
1.4.8 Brake band (tightening torque)	5/19
1.4.9 Adjustment of accelerator cable (full throttle)	5/20
1.5 Tightening torques	6
1.6 Troubleshooting (fault, cause, remedy)	7/1
1.7 Examination of transmission	8
1.8 Special tools	9/1
2. Disassembly	10
2.1 Disassembling transmission according to components	10
2.2 Brake C'	21
2.3 Brake D	23
2.4 Intermediate plate with brake C and pump	24
2.5 Clutch B with 2nd gear freewheel	25
2.6 Clutch A	28
2.7 Clutch E	30
2.8 Output shaft and 1st gear freewheel	31
2.9 Governor and differential	33
2.10 Input shafts and converter bell housing with speedometer	36
2.11 Housing with selector mechanism and park interlock	41
3. Assembly	47
3.1 Transmission housing with selector mechanism and park interlock	47
3.2 Brake C'	57
3.3 Brake D with 1st gear freewheel	61
3.4 Planetary gear set with input and output parts	66
3.5 Engine shaft with clutch E	71
3.6 Clutch A	74
3.7 Clutch B	78
3.8 Intermediate plate with pump and brake C, 2nd gear freewheel	81
3.9 Governor, counter shaft and spur gear train	88
3.10 Differential, input shafts and converter bell housing with speedometer	94
3.11 Control unit, oil pan, oil filter and converter	105

PREINFORMATION

This manual contains the exact procedures to be adopted when repairing the complete transmission.

All the work involved in disassembly and assembly is listed in chronological order.

The photographs used in the illustrations have been kept general in nature for the different types of transmissions and are not binding.

The transmission version is precisely specified by the parts list and can be determined by referring to the spare parts lists.

Important modifications which have to be taken into account when performing repairs, are advised in the Technical Circulars.

Depending on the extent of the damage, the work performed may be limited to that necessary for rectifying the damage.

It is recommended to note the following points:

- Always renew accelerator cable and seals, such as O rings, shaft seals, sealing bushes and paper gaskets.
- Replace all the lined and steel discs on transmissions which have covered more than 50.000 km.
- If the clutch has been damaged, it is essential to thoroughly clean torque converter, oil cooler lines and oil cooler with a suitable cleaning agent.

The following preconditions should exist:

- Availability of the necessary special tools. The complete set of special tools is listed in Section 1.8.
- Availability of a suitable transmission test stand. Reference should be made to the „Technical Circulars” for the relevant test figures.

NOTE:

The control unit is treated as a complete unit in this manual and should not be disassembled in the absence of specialist knowledge, but should be replaced as a complete part.

The separate repair manual should be used for performing repair work on the control unit.

Caution:

The quantity of oil filled into the transmission for delivery should be that stated in the relevant parts list documentation (microfiches).

1. General

1.1 Illustration of transmission

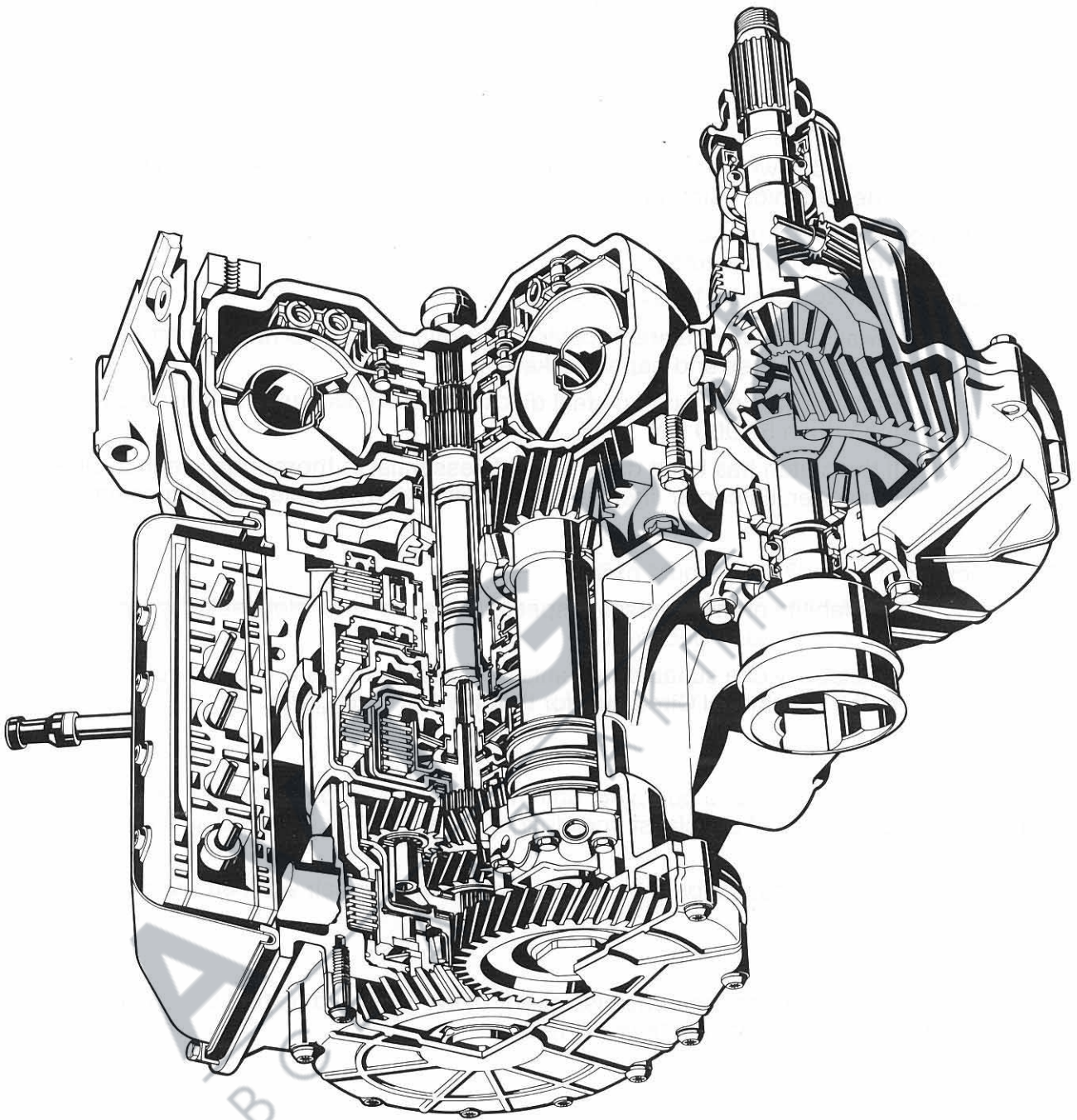

1.2 Power flow

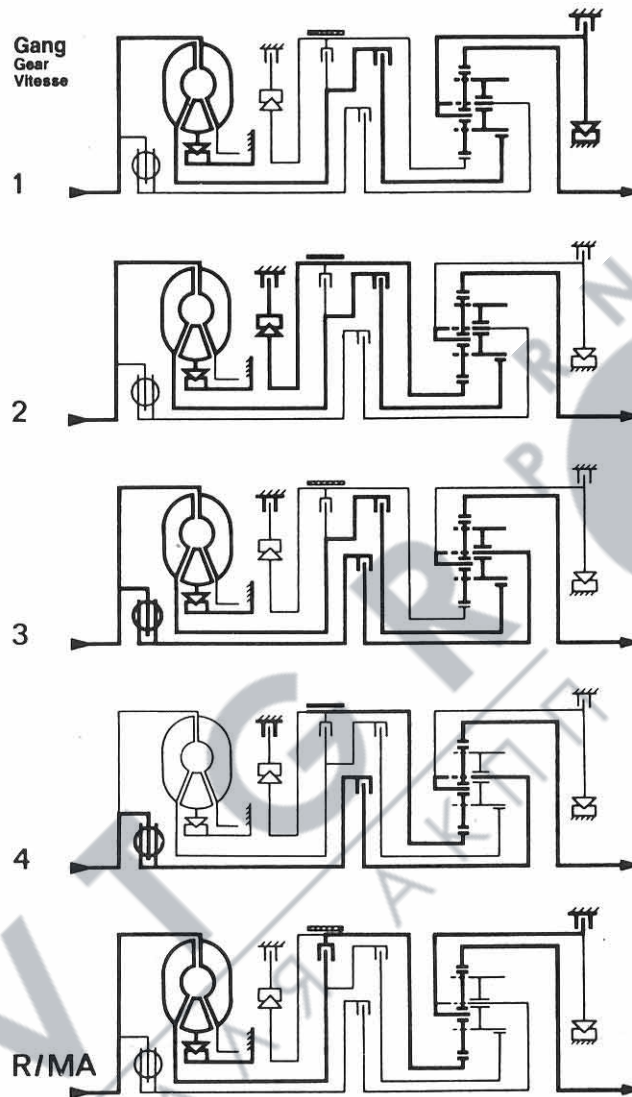

Reference should be made to Technical Circular, File 401.3, Group 008/010, of 22.10.84, for a full description.

The power flow of 4 HP 14 and 4 HP 18 is identical.



1.4 Adjustments

1.4.1 Clearance of selector shaft mechanism washer

85 216

Screw adjusting tool
5 P 95 000 301 onto housing and
press cam against the teeth of the
locking cam with no clearance.

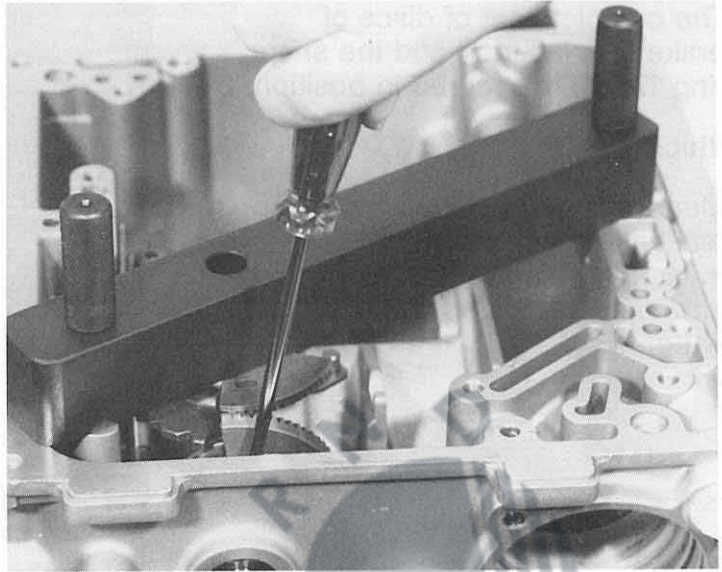

85 217

Use a feeler gauge to measure the
size X between housing and cam.

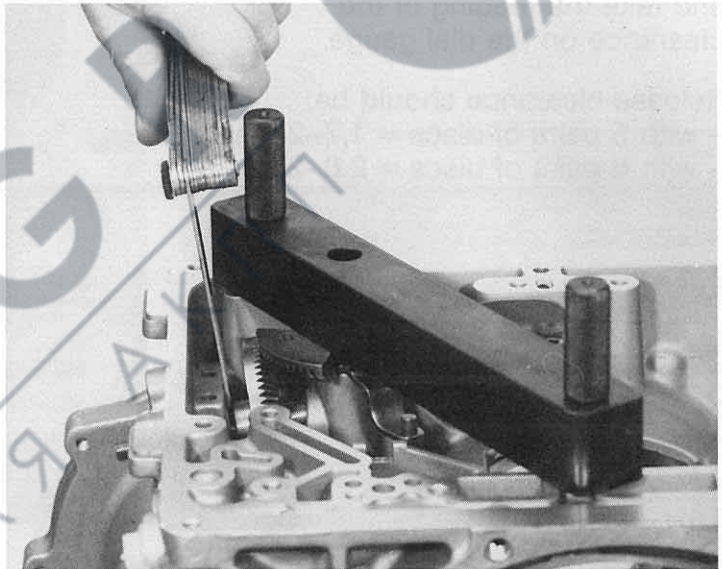

Thickness of washer 'S' is determined using the following formula:

$$S \text{ (mm)} = X \text{ (mm)} - 0,10 \text{ (mm)}$$

S = Thickness of washer

X = Value to be measured

0,10 = Selected clearance

(0,10 - 0,20 acc. to parts list)

Example:

Using the feeler gauge, size X is found to be 2,3 mm.

$$S = 2,3 \text{ mm} - 0,10 \text{ mm}$$

$$S = 2,2 \text{ mm}$$

It is necessary to insert **2** washers with a total thickness of $S = 2,2 \text{ mm}$.

1.4.2 Release clearance of brake D (snap ring)

85 244

Requirement:

The complete set of discs of brake D is inserted and the snap ring 17.080 is secured in position.

(thickness selected = 1,0 mm)

Mount square measuring bar and dial gauge with extended measuring tip. Position tip on the end disc and set scale of dial gauge to '0'.

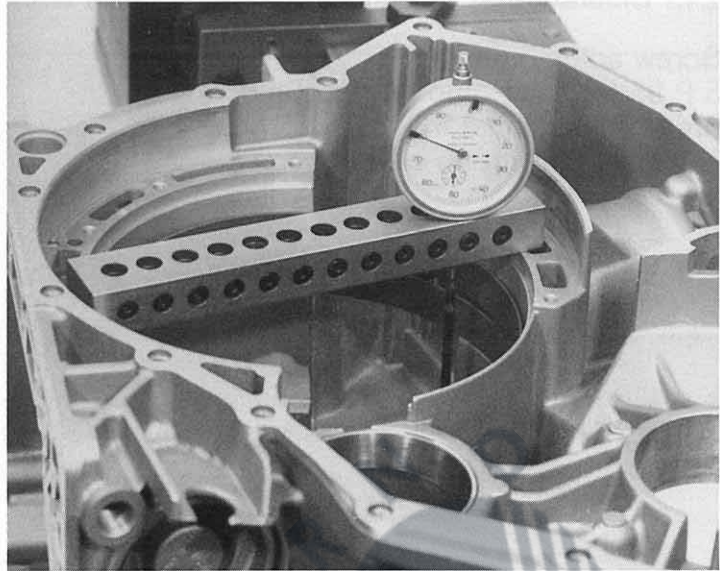

Raise the complete set of discs and take the reading of the clearance on the dial gauge.

Release clearance should be:

- with 5 pairs of discs = 1,7–2,2 mm
- with 6 pairs of discs = 2,0–2,5 mm

85 245

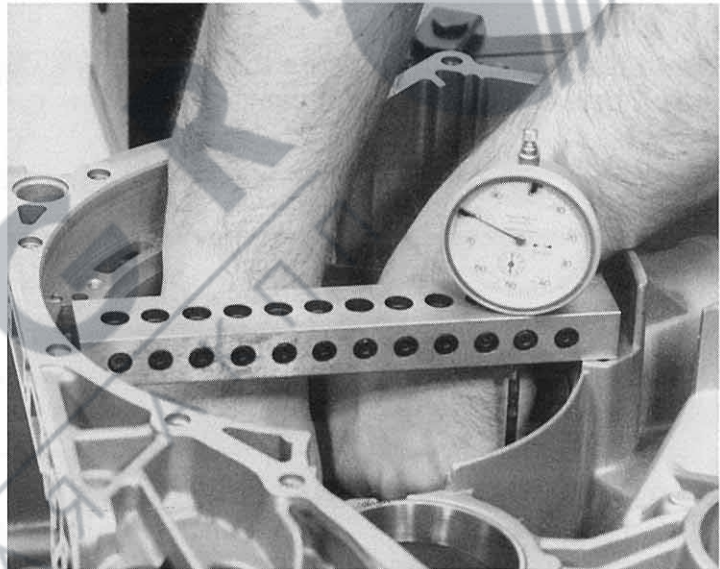

If the reading differs from this, an appropriately thicker or thinner snap ring must be inserted.

85 236

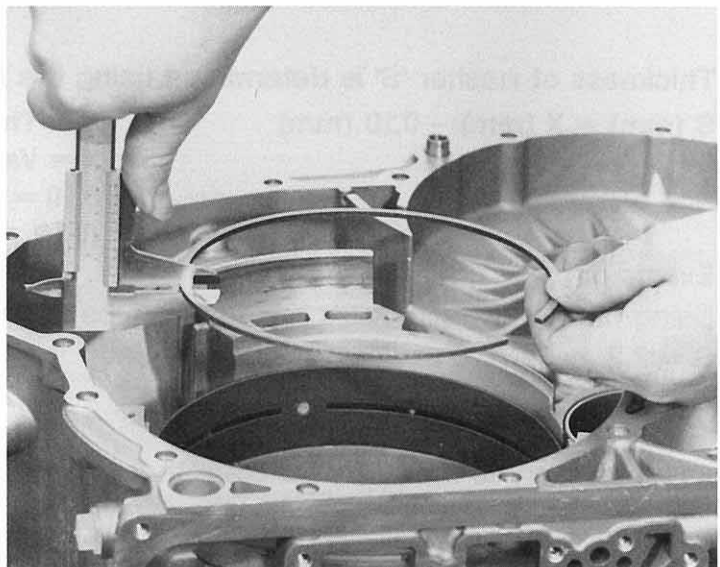

1.4.3 Release clearance of clutch A (snap ring)

85 271

Secure snap ring 02.160 in position.
(thickness selected = 1,0 mm).

Mount measuring bar with dial gauge.

Position measuring tip on the
end disc and set scale of dial gauge to '0'.

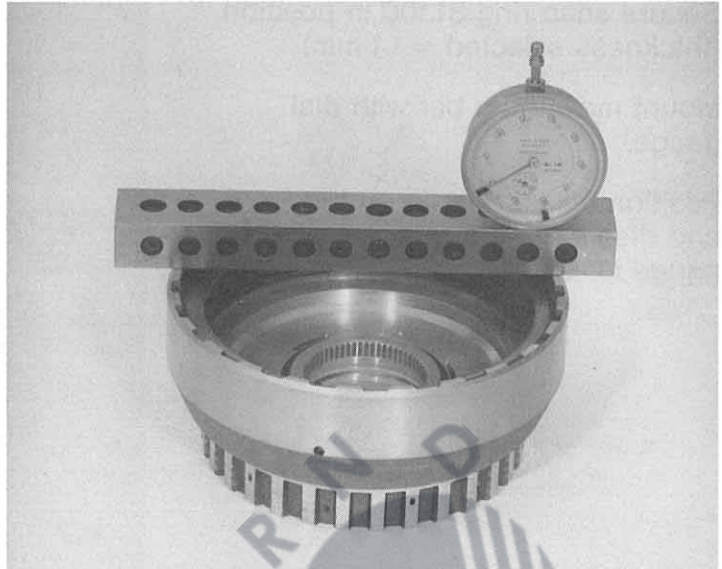

Raise the complete set of discs
and take the reading of the
clearance on the dial gauge.

Release clearance should be:

- with 4 pairs of discs = 1,8–2,0 mm
- with 5 pairs of discs = 2,3–2,5 mm

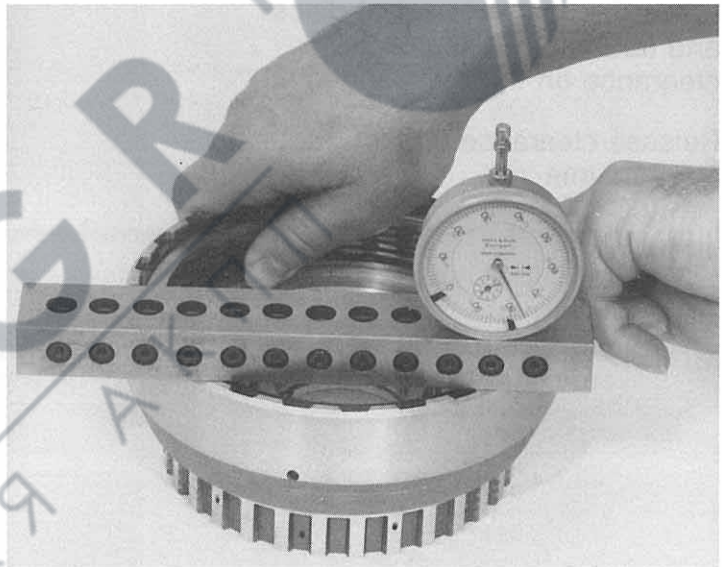

If the reading differs from this,
an appropriately thicker or
thinner snap ring must be
inserted.

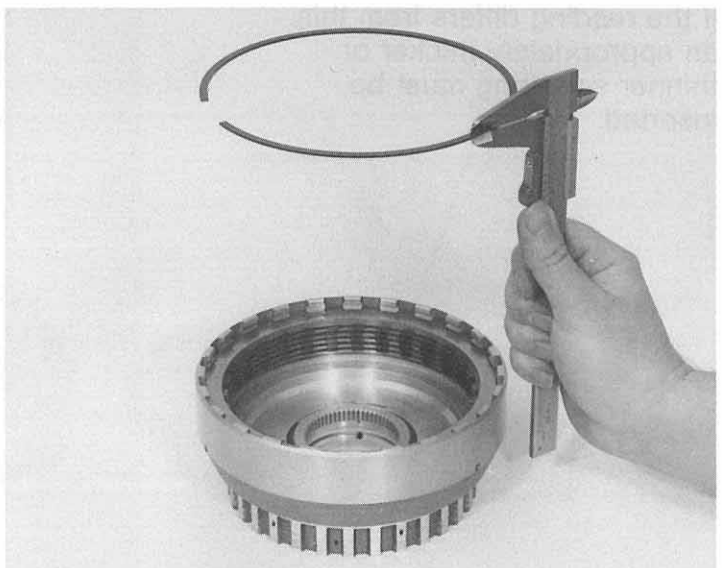

1.4.4 Release clearance of brake C (snap ring)

85 294

Secure snap ring 31.100 in position.
(thickness selected = 1,1 mm).

Mount measuring bar with dial
gauge.

Position measuring tip on the
end disc and set scale of dial
gauge to '0'.

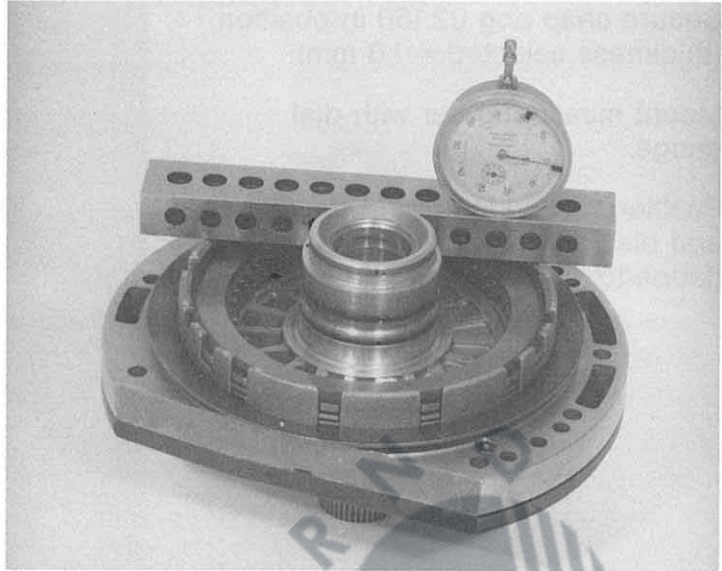

Raise the complete set of discs
and take the reading of the
clearance on the dial gauge.

Release clearance should be
1,4 – 1,6 mm

85 295

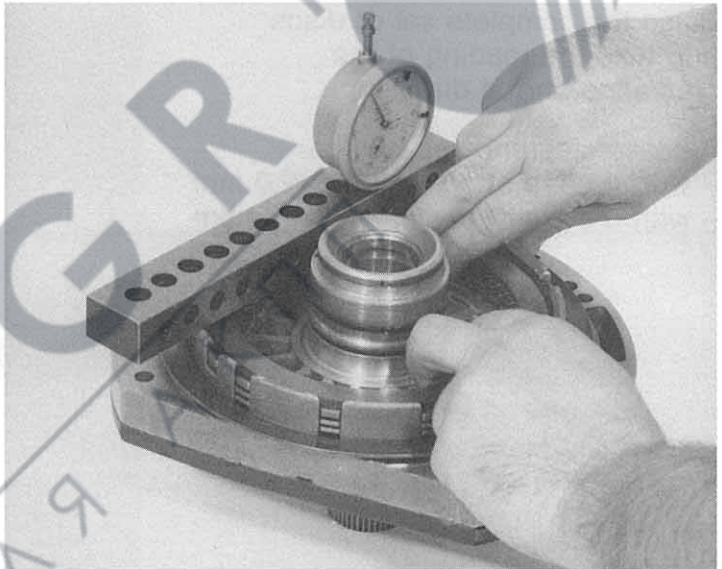

If the reading differs from this,
an appropriately thicker or
thinner snap ring must be
inserted.

85 296

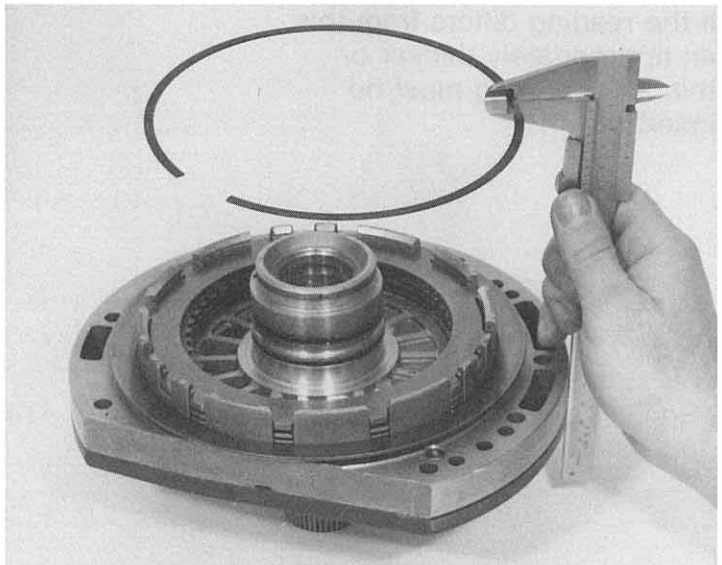

1.4.5 Axial clearance (washer)

85 301

Fit adjusting washer 22.090 (thickness selected = 1,0 mm) and angle washer 22.080 onto the hub of cylinder B.

(Do not install the freewheel of 2nd gear for the measurement operation).

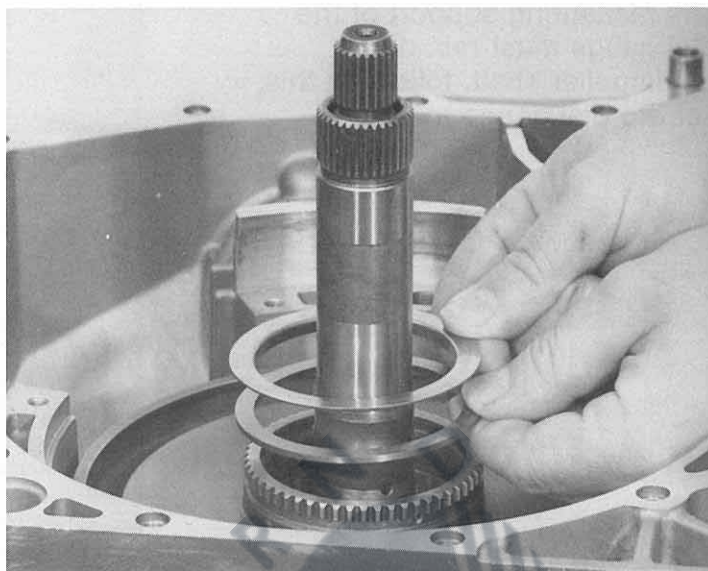

Insert the complete pump/intermediate plate unit, turning it back and forward long enough for the plate springs of brake C to be abutting on the transmission housing and fix in place with 2 opposite cylindrical bolts. (Tightening torque = 10 Nm).

85 302

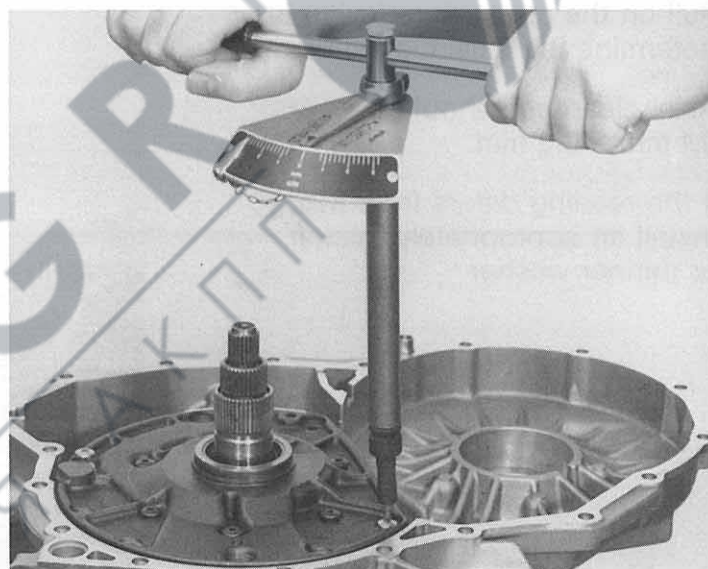

Mount measuring tool 5 P 01 001 522 onto the turbine shaft and clamp tight.

85 303

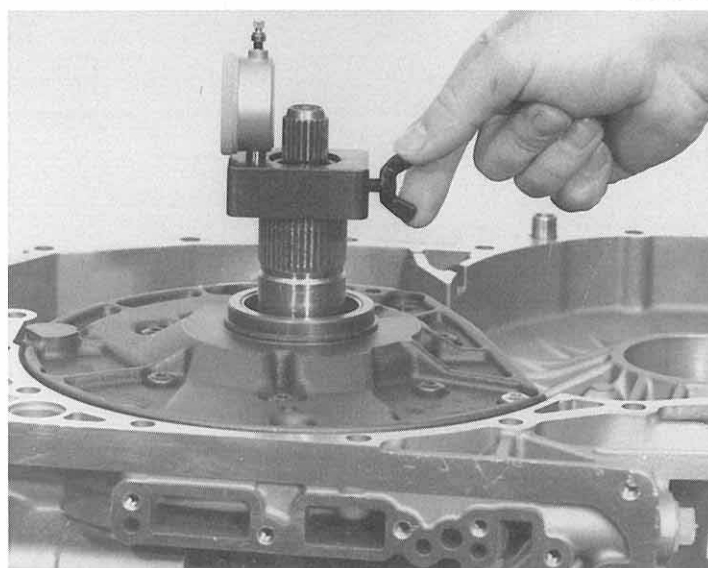

85 304

The measuring support of the dial gauge must rest on the impeller shaft; following this, set the dial gauge to '0'.

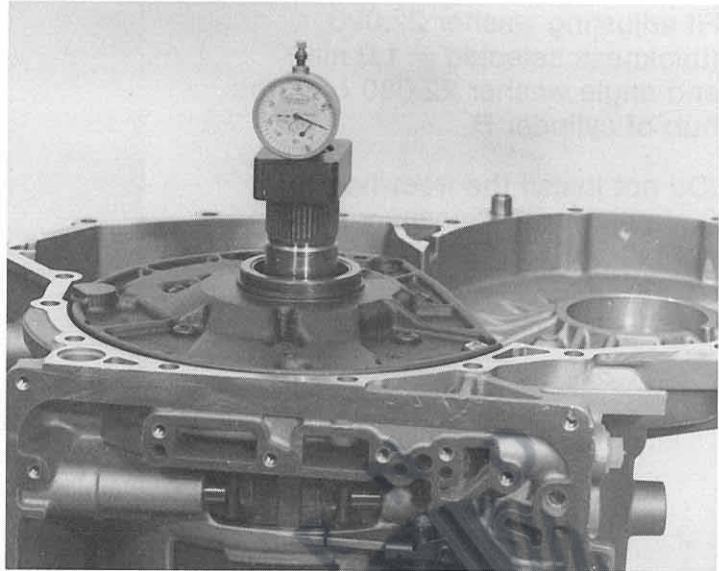

Pull on the measuring device to determine the axial clearance.

Axial clearance should be 0,1 mm – 0,3 mm.

If the reading differs from this, install an appropriately thicker or thinner washer.

85 305

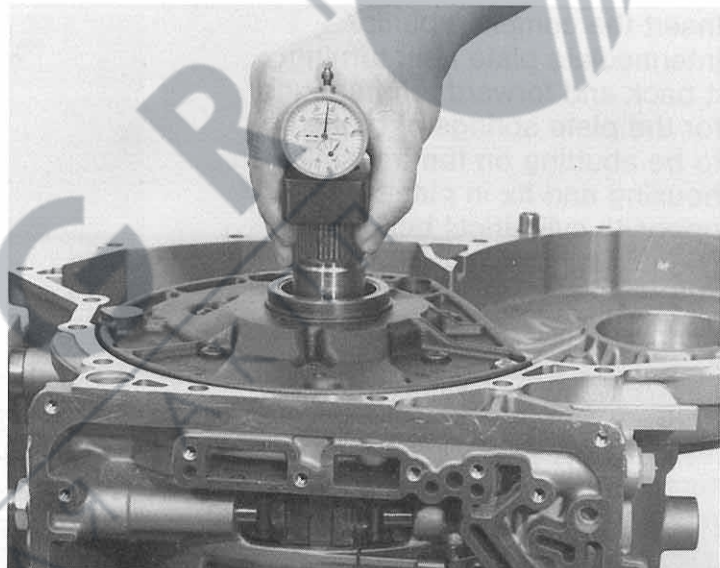

1.4.6 Spur gear drive

1.4.6.1 Preload of output shaft (washer)

85 323

Method A

First install the washer 09.024 (thickness selected = 1,90 mm) and the matching spur gear (taper roller bearings differ) onto the **counter shaft** and loosely tighten bolt.

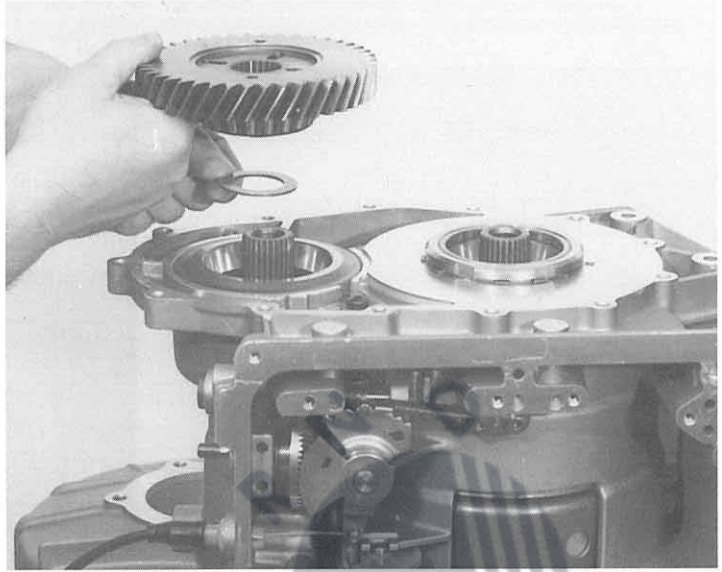

85 324

Use a suitable screwdriver or mandrel to press out the three tension pins of adjusting ring 5 P 95 000 351. Place ring on a suitable base (e.g. washer).

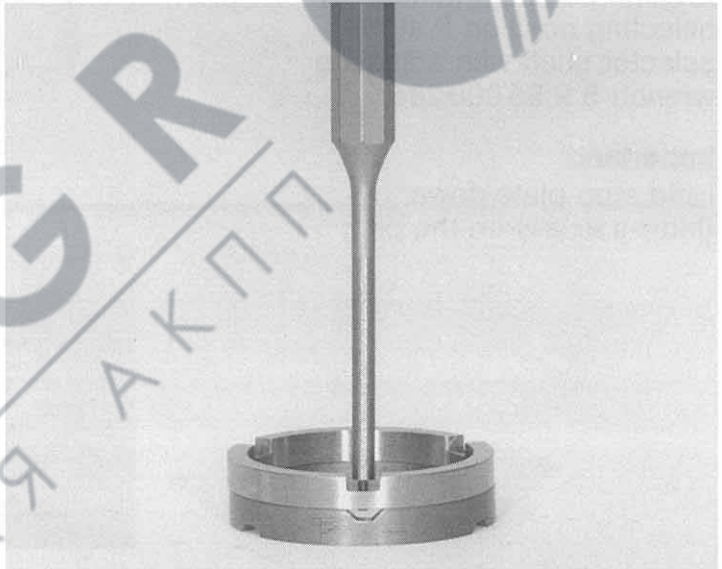

85 325

Fit adjusting ring onto the tapered roller bearing inner ring of the output shaft with the tension pins facing up.

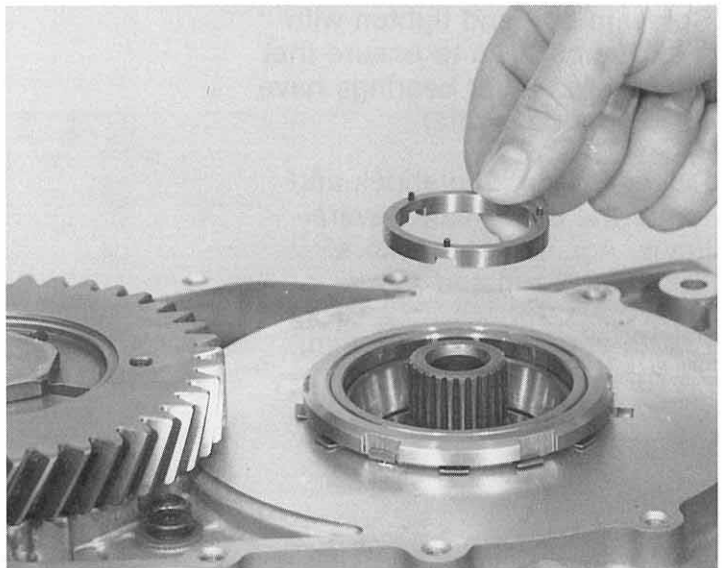

85 326

Fit on spur gear.

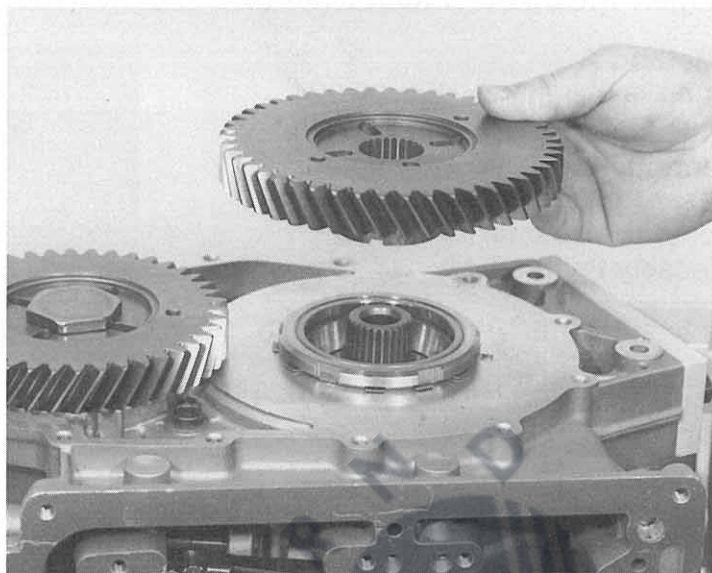

85 327

Engage parking interlock by selecting position P at the selector shaft with adjusting wrench 5 P 95 000 285.

Important!

Hold stop plate down.
(Moves axially on the pin).

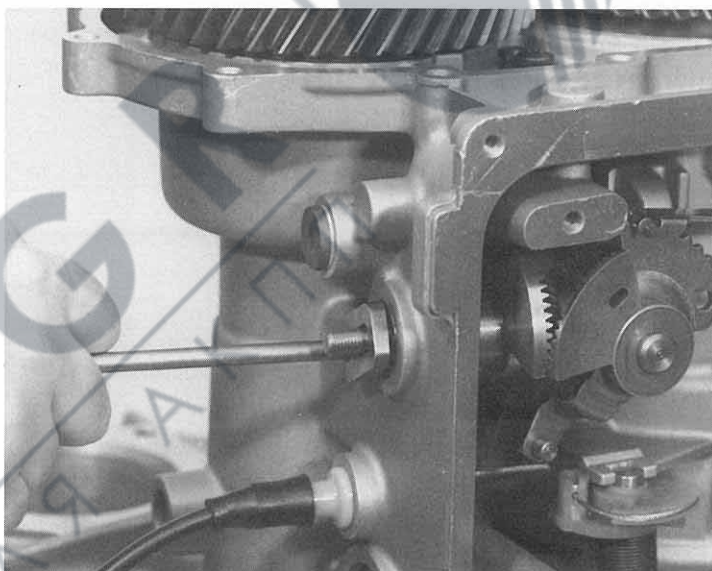

85 328

Screw in bolt and tighten with a torque of 5 Nm to ensure that the tapered roller bearings have no clearance (settle).

Release parking interlock and rotate the spur gears several times. Again tighten with a torque of 5 Nm and rotate.

(Width across flats = 36 mm)

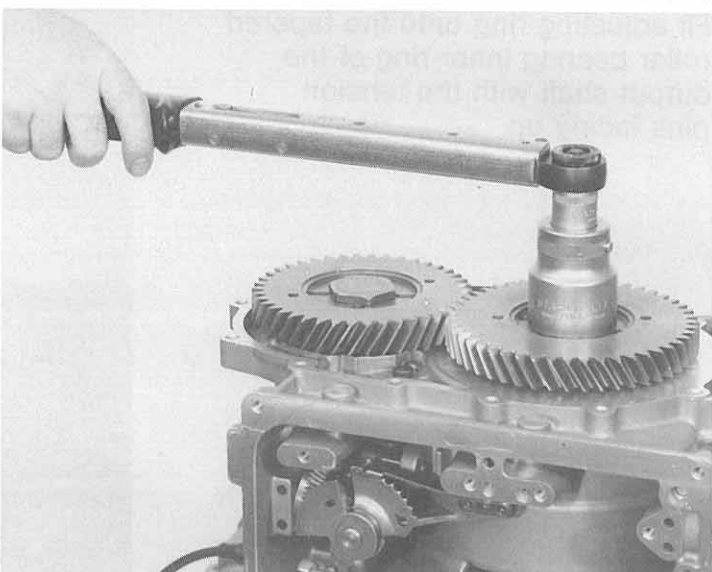

Slacken bolt, remove spur gear and use the micrometer gauge to measure the calculated thickness of the washer at the three tension pins of the adjusting ring.

e.g. 1st tension ring 6,34 mm,
2nd tension ring 6,34 mm,
3rd tension ring 6,33 mm.



Average the three readings and install the nearest washer from the tables in the parts list (spare parts list).

e.g. 6,32 mm.

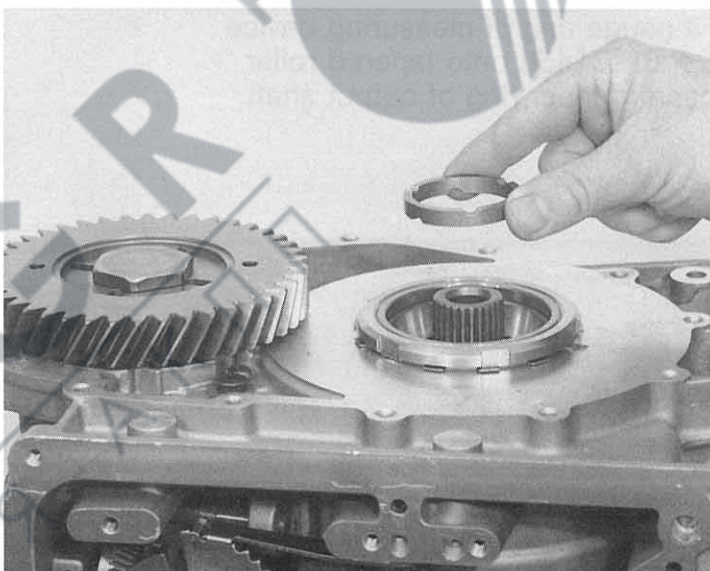

Method B

First fit the washer 09.024 (thickness selected = 1,90 mm) and the matching spur gear onto the **counter shaft** and loosely tighten bolt.

85 323

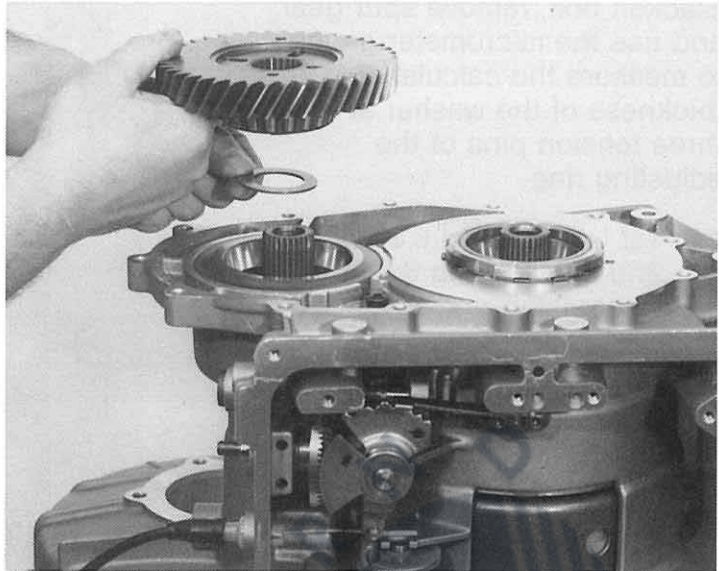

Fit gauge ring of measuring device 5 P 01001458 onto tapered roller bearing inner ring of output shaft.

85 332

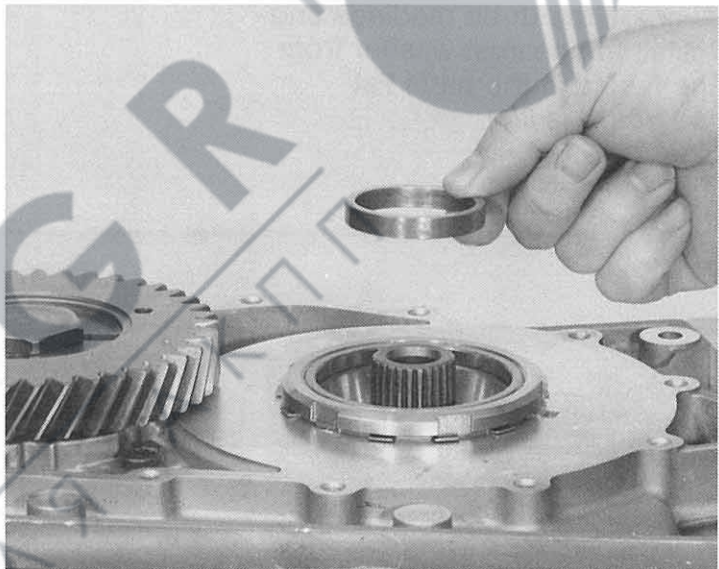

Fit on spur gear and tighten bolt of measuring device with a torque of 30 Nm.

(Width across flats = 36 mm)

85 333

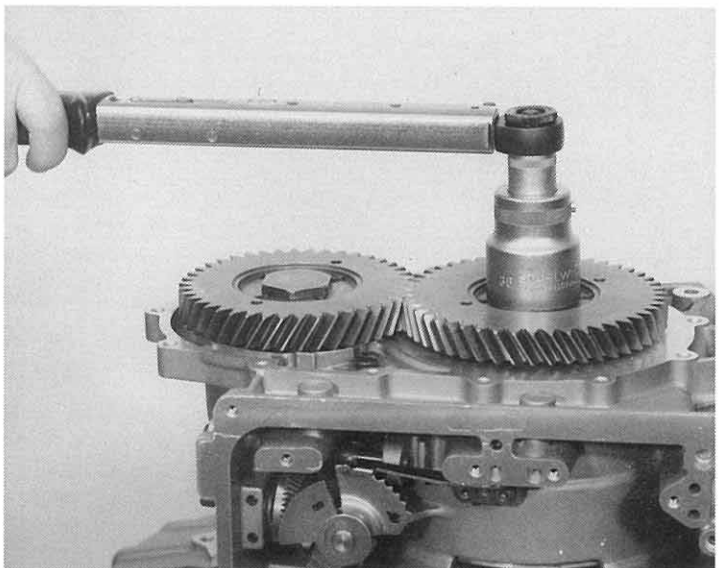

85 334

Screw measuring device
5 P 01 001 458 tightly in the
position in which the pin can be
inserted at the same time into
the bar of the spindle and the
bolt.

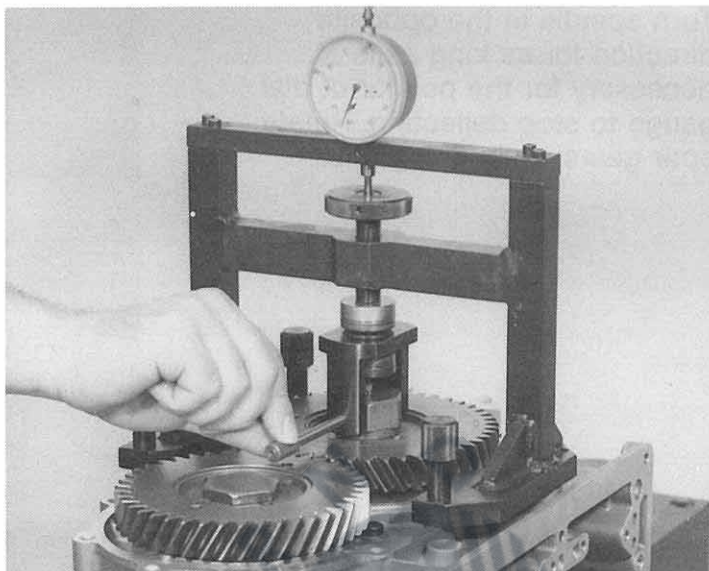

85 335

Turn the spindle of the measuring
device for as long as is necessary
for the pointer of gauge to settle,
while rotating the spur gears.

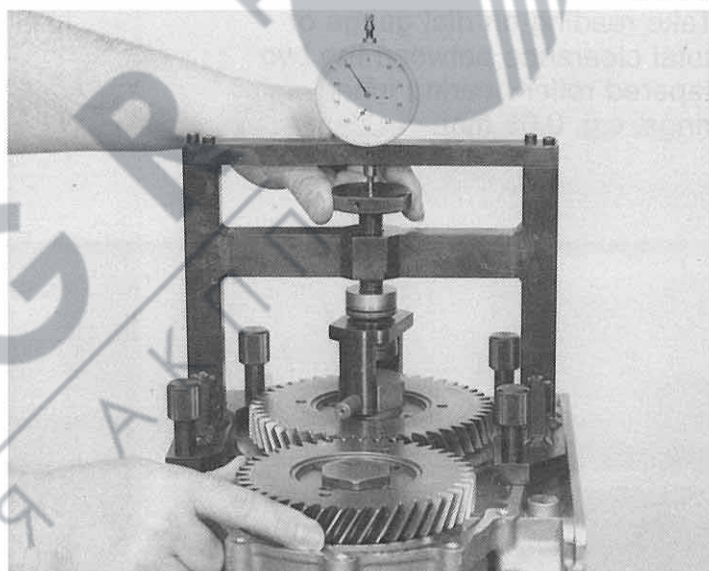

85 336

Set dial gauge to '0'.

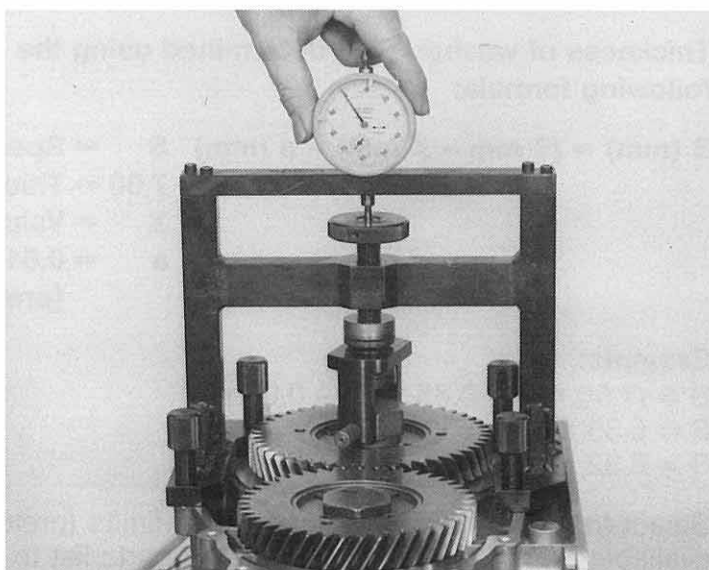

Turn spindle in the opposite direction for as long as is necessary for the pointer of dial gauge to stop deflecting. Rotate spur gears while doing this.

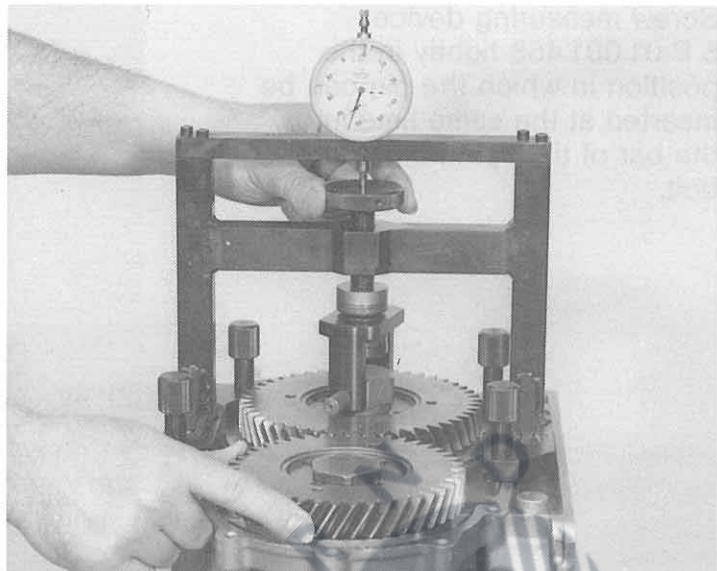

Take reading on dial gauge of total clearance between the two tapered roller bearing inner rings, e.g. 0,65 mm.

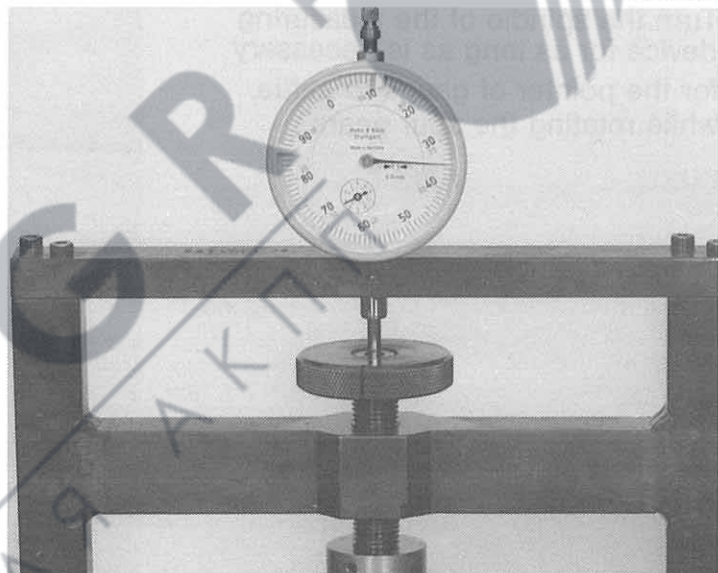

Thickness of washer 'S' is determined using the following formula:

$$S \text{ (mm)} = (7 \text{ mm} - X \text{ mm}) - a \text{ (mm)}$$

S = Spec. thickness of washer
7,00 = Thickness of gauge ring
X = Value to be measured
a = 0,01 mm – 0,04 mm
 (preload acc. to parts list)

Example:

$$S = (7,00 \text{ mm} - 0,65 \text{ mm}) - 0,03 \text{ mm}$$

$$S = 6,35 \text{ mm} - 0,03 \text{ mm}$$

$$S = 6,32 \text{ mm}$$

Select the size 'a' within the specified limits (preload) so as to enable a washer available from the tables of the spare parts list to be used.

1.4.6.2 Clearance of counter shaft (washer)

85 339

Requirements:

Washer 09.024 = 1,90 mm thick is inserted, the spur gear mounted and loosely tightened with the bolt, the pretensioning device 5 P 95 000 300 is also mounted on the differential side of the counter shaft.

Note

Always insert the thickest washer from the materials tables of the spare parts list to assure clearance.

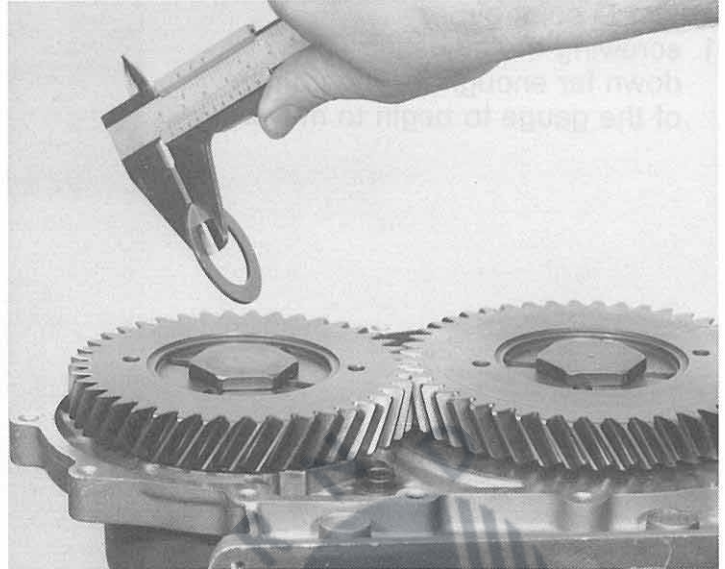

Engage parking interlock and tighten bolt with a torque of 150 Nm. Release parking interlock.

(Width across flats = 36 mm)

85 340

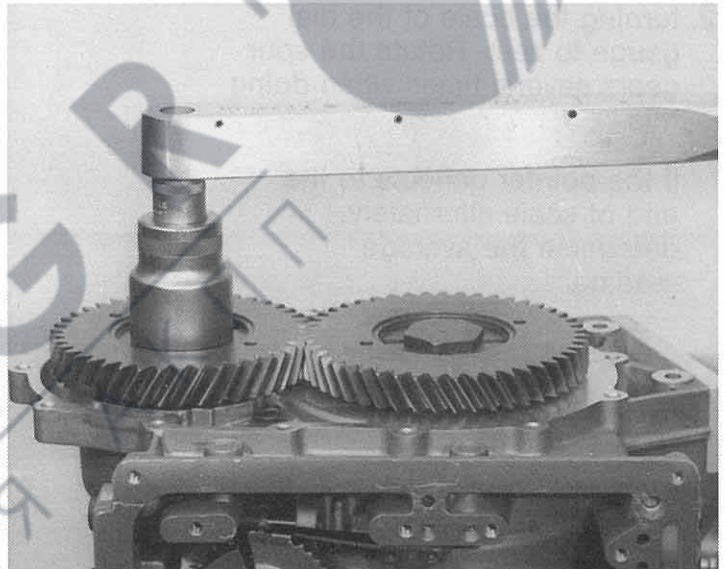

Screw on measuring tool 5 P 01 001 523 with dial gauge.

85 341

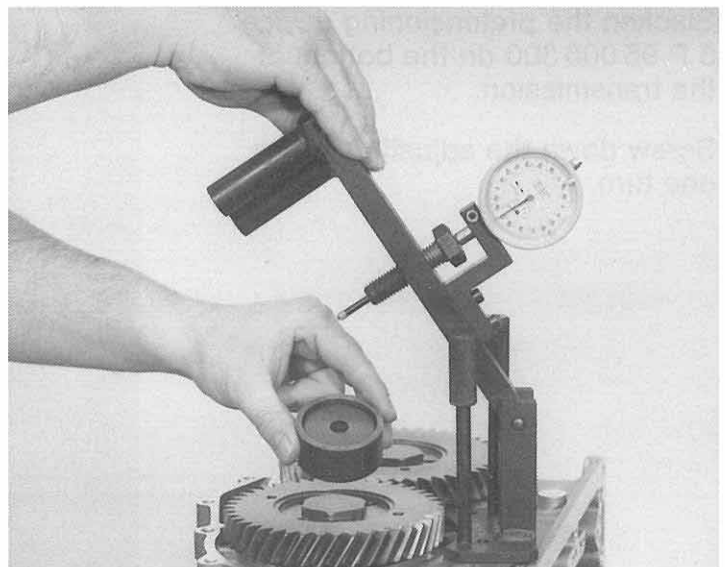

85 342

Adjust O point by

1. screwing the adjusting screw down far enough for the pointer of the gauge to begin to move.

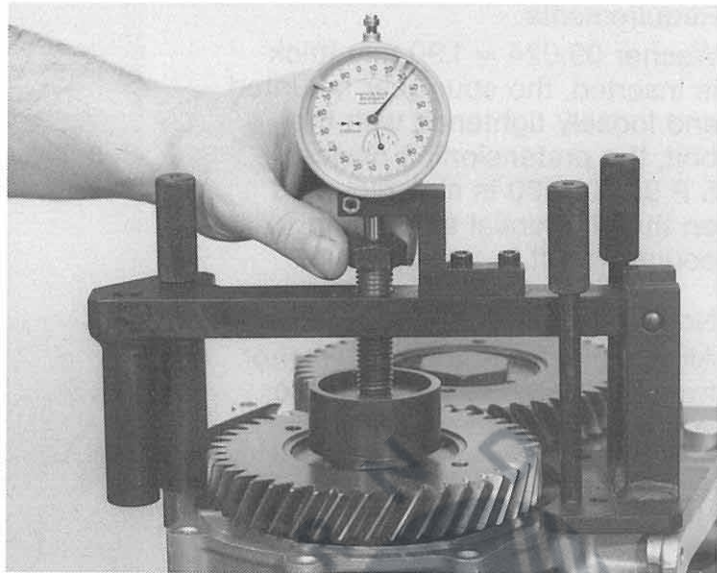

85 343

2. turning the scale of the dial gauge to zero. Rotate the spur gears several times when doing this.

If the pointer deflects to the end of scale alternately, determine the average reading.

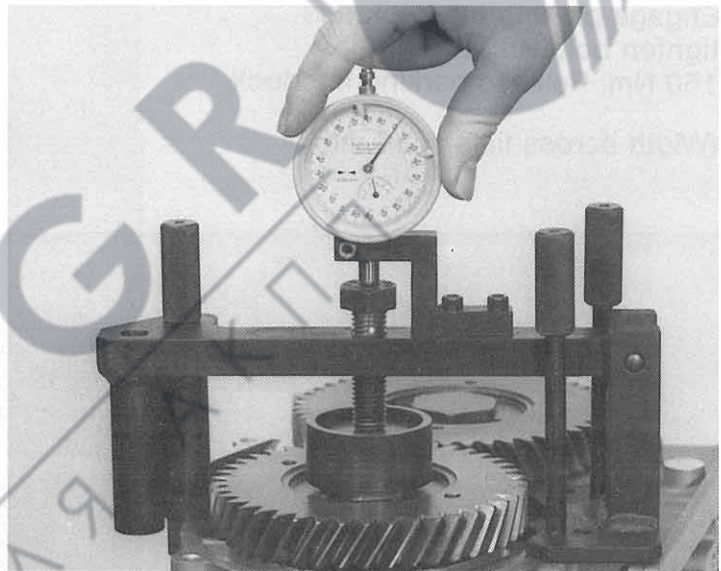

85 344

Slacken the pretensioning device 5 P 95 000 300 on the bottom of the transmission.

Screw down the adjusting screw one turn.

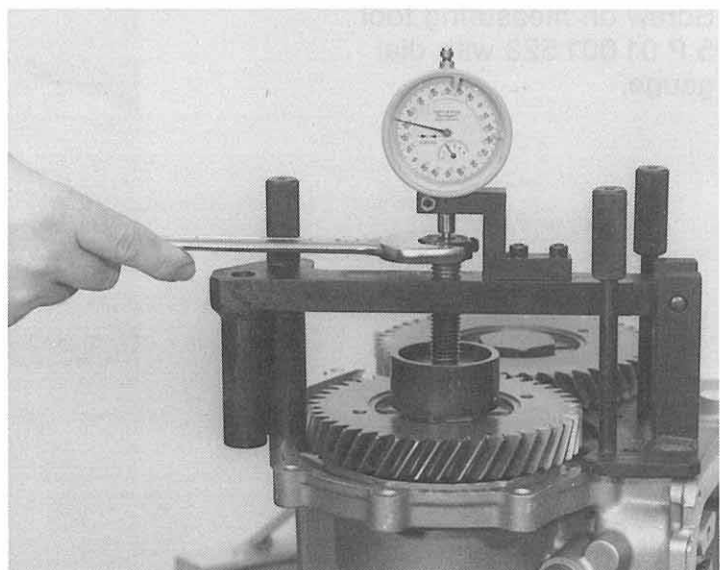

Rotate spur gears several times until the pointer of the dial gauge has settled (take average of reading).

Take reading of size X e.g. 0,92 mm.

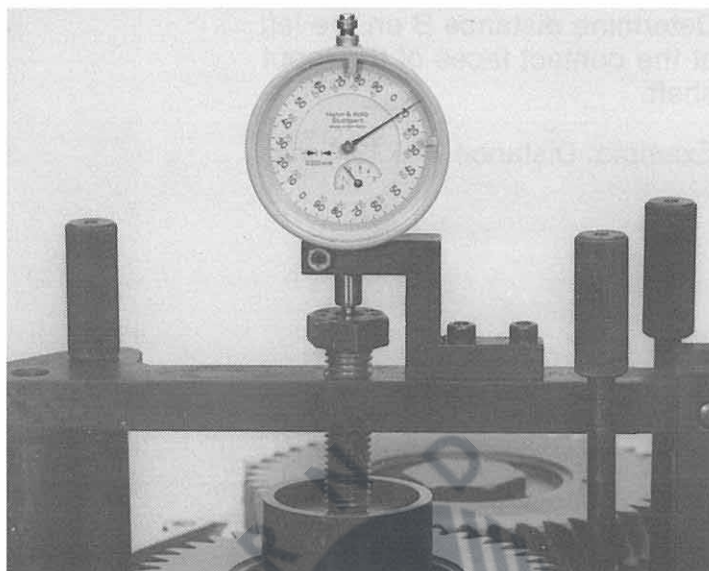

Thickness of washer 'S' is determined using the following formula:

$$S = 1,90 \text{ mm} - (X \text{ mm} - 0,08 \text{ mm})$$

S = Spec. thickness of washer
X = Reading on gauge
0,08 = Clearance selected (0,05 – 0,10 mm) acc. to parts list)

Example:

$$S = 1,90 \text{ mm} - (0,92 \text{ mm} - 0,08 \text{ mm})$$

$$S = 1,90 \text{ mm} - 0,84 \text{ mm}$$

$$S = 1,06 \text{ mm} \text{ (rounded down = 1,05 mm)}$$

The selected washer 1,90 mm thick must be replaced by a 1,05 mm thick washer. Round up or down, as appropriate.

If it is necessary to install a washer of a different thickness, it is recommended to repeat the measurement (as a check). Bolt must be tightened with a torque of 150 Nm.

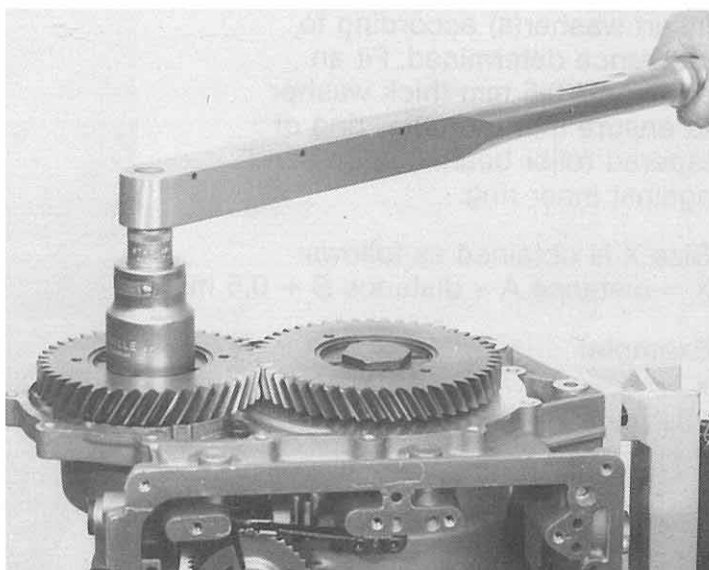

1.4.7. Preload of differential (washer)

85 378

Determine distance B on the left at the contact faces of the input shaft.

Example: Distance B = 19,4 mm

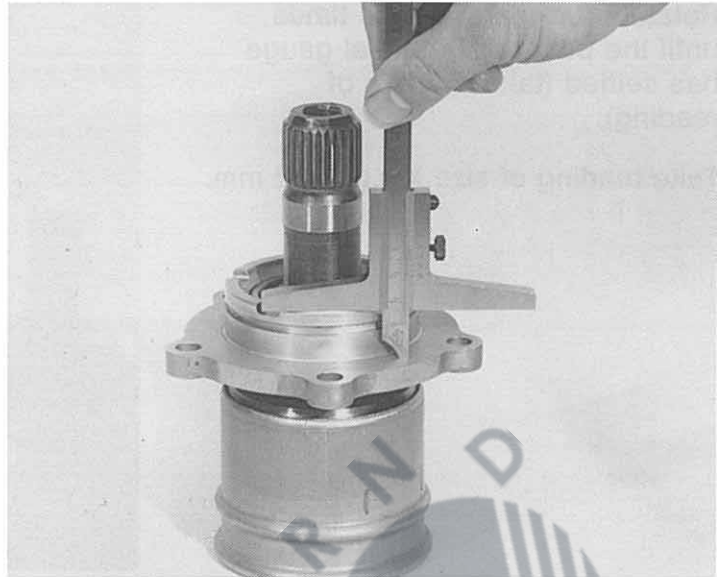

Measure distance A between machined surface of converter bell housing and outer ring of tapered roller bearing.

Example:

Distance A = 20,2 mm

Determine bearing clearance.

Clearance = distance A - distance B

Example:

Clearance =

20,2 mm - 19,4 mm = 0,8 mm

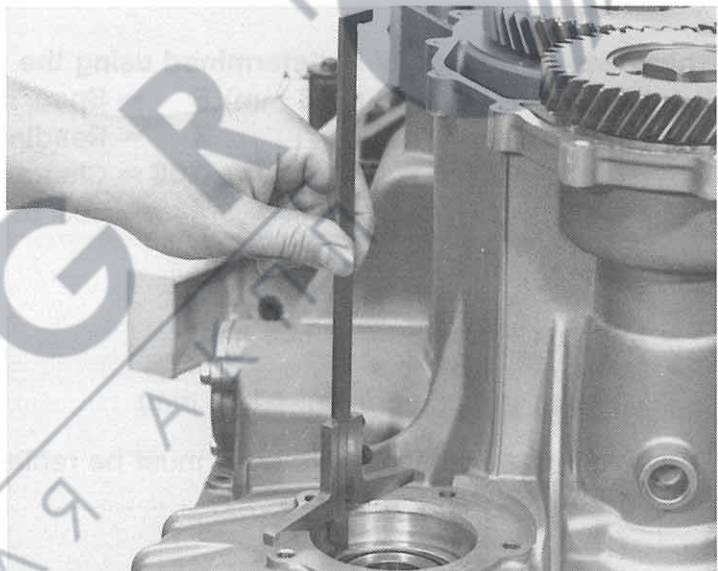

85 379

Insert washer(s) according to clearance determined. Fit an additional 0,5 mm thick washer to ensure that the outer ring of tapered roller bearing is pressed against inner ring.

Size X is obtained as follows:

$X = \text{distance A} - \text{distance B} + 0,5 \text{ mm}$

Example:

X =

20,2 mm - 19,4 mm + 0,5 mm = 1,3 mm



85 380

Screw on input shaft with 5 hexagon bolts.

The O ring may be removed during the measurement operation to enable the input shaft to be better fitted.

(Width across flats = 13 mm)
(Tightening torque = 23 Nm)

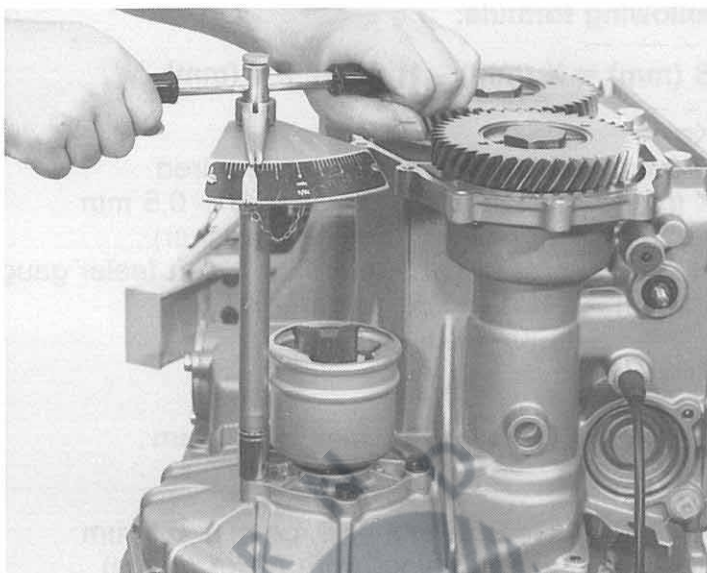

Turn the fastening bolt (counter shaft) several times to cause the tapered roller bearing to settle.

(Width across flats = 36 mm)

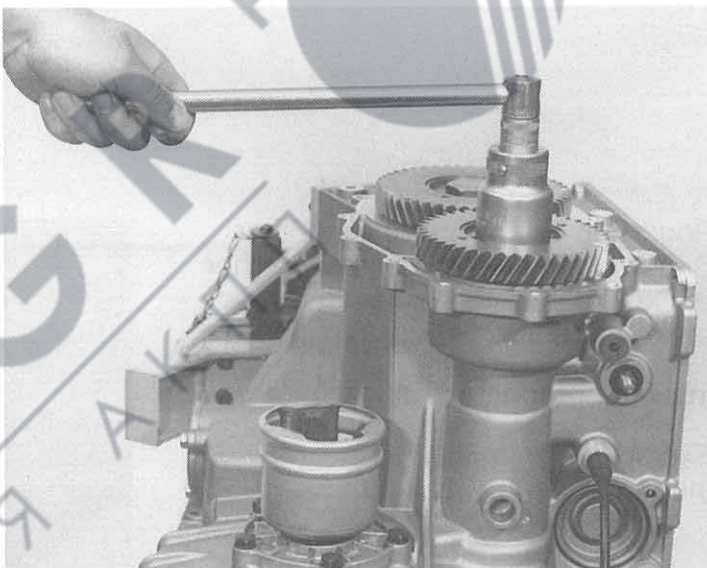

Remove the 5 hexagon bolts again and use the feeler gauge to determine size of gap H.

e.g. 0,4 mm

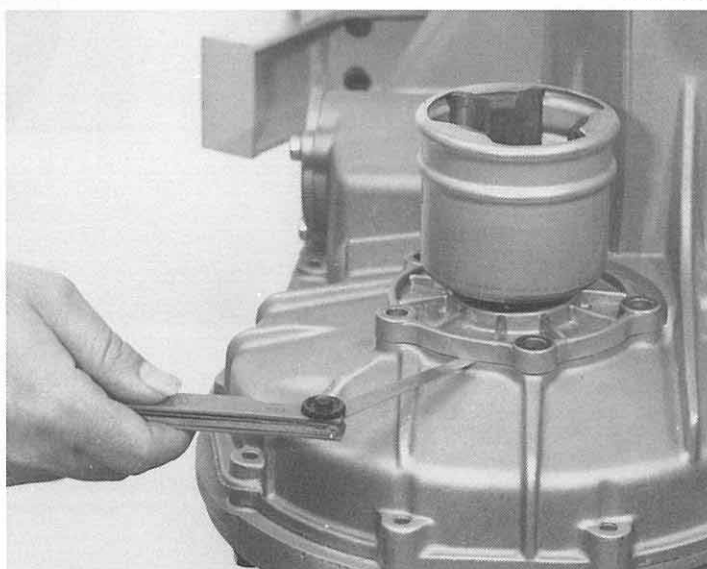

Thickness of washer 'S' is determined using the following formula:

$$S \text{ (mm)} = X \text{ (mm)} - H \text{ (mm)} + V \text{ (mm)}$$

Key:

S (mm) = thickness of washer required

X (mm) = distance A – distance B + 0,5 mm
(0,5 mm = additional washer)

H (mm) = size of gap, determined with feeler gauge

V (mm) = preload acc. to parts list
= 0,10 – 0,15 mm

Example:

$$S \text{ (mm)} = 1,3 \text{ mm} - 0,4 \text{ mm} + 0,10 \text{ mm}$$

S = 1,0 mm

X = 1,3 mm = 20,2 mm – 19,4 mm + 0,5 mm

H = 0,4 mm (determined with feeler gauge)

V = 0,10 mm (preload, selected within specified limits)

Round up or down size of washer S determined to the nearest washer thickness from the tables in the spare parts list.

Install appropriate washer(s).

Example:

Insert washer(s) 1,0 mm thick.

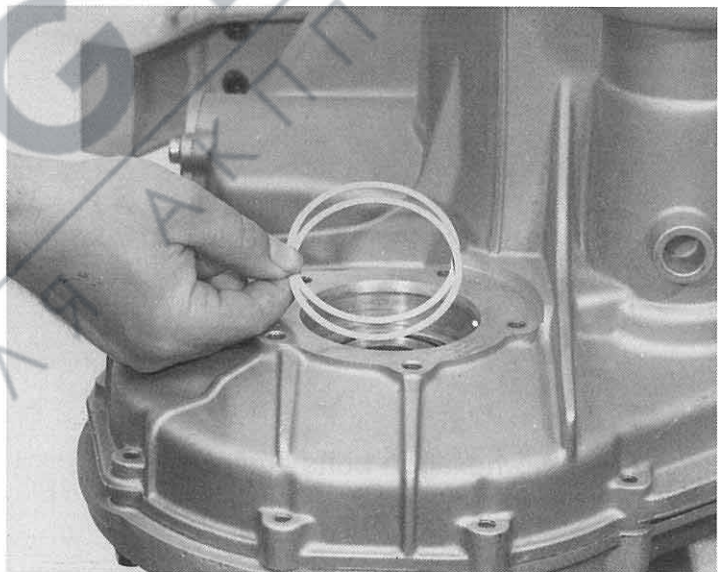

85 384

1.4.8 Brake band (tightening torque)

85 386

Apply a light coating of ATF oil to cylinder B. Tighten adjusting bolt with 10 Nm.

(Width across flats = 6 mm internal hex.)

Important!

Turn cylinder B during tightening operation to ensure brake band is not twisted.

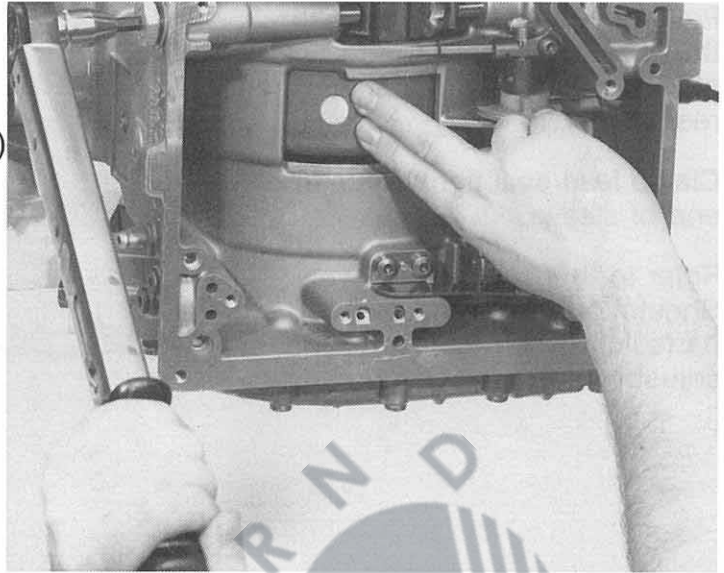

Slacken adjusting bolt 2 turns (approx. 3 mm). Mark the adjusting screw and housing when doing this.

85 387

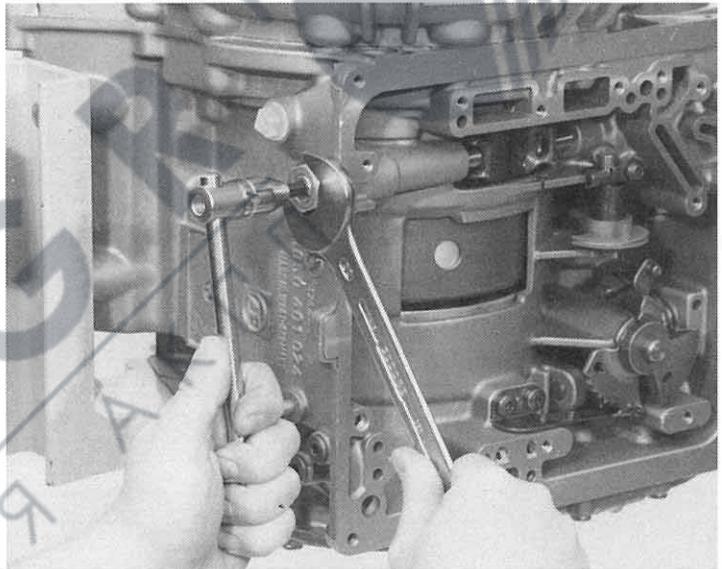

Tighten locking nut with torque of 80 Nm.

(Width across flats = 23 mm)

85 388

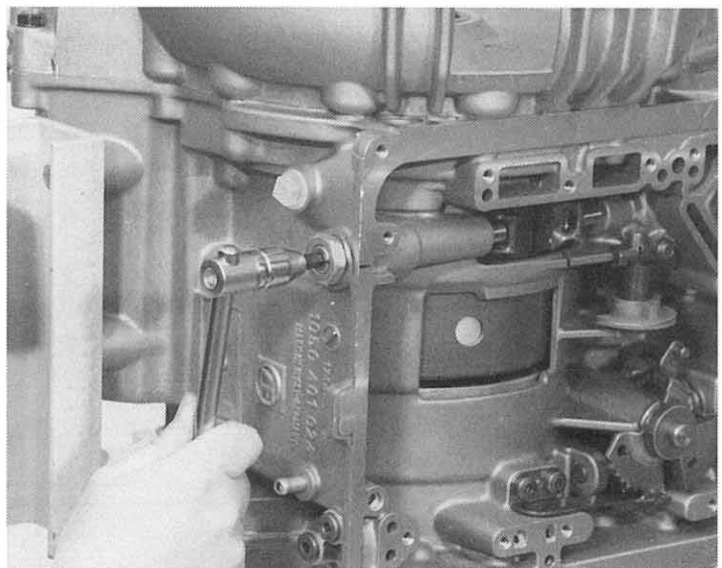

1.4.9 Adjustment of accelerator cable (full throttle)

85 398

Pull out accelerator cable with the sleeve extended to the point of kick-down rise (perceptible resistance).

Clamp lead seal tight X mm from end of sleeve.

Refer to the 'Technical Cover Sheets' of the individual spare parts lists (microfiches) for the adjustment 'C'.

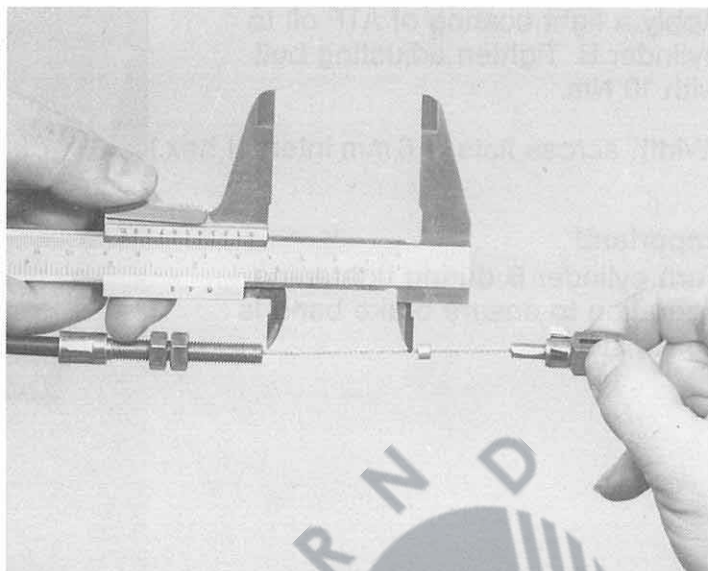

AVTGR
ВСЕ ДЛЯ АКПП
P R N D

1.5 Tightening torques

Designation	Wrench size	Page	Tightening torque
- Screw plug (transm. hsg.)	Hex. socket waf = 5 mm	48	15 Nm
- Cylindrical bolt (pin of ratchet)	TORX-TX 27	50	10 Nm
- Screw plug (parking interlock)	Hex. socket	52	32 Nm
- Cylindrical bolt (detent spring)	TORX-TX 27	53	10 Nm
- Cylindrical bolt (selector parts)	TORX-TX 27	56	10 Nm
- Slotted nut	5 X 46 000 155	65	50 Nm
- Cylindrical bolt (interm. pl., pump)	TORX-TX 27	83	10 Nm
- Cylindrical bolt (interm. pl., transm. hsg)	TORX-TX 27	88	10 Nm
- Cylindrical bolt (gov. hsg., flange)	TORX-TX 27	90	10 Nm
- Bolt (output shaft/counter shaft) Important! Adjustment -	Hexagon waf = 36 mm	93 5/13	150 Nm
- Locking bolt (spur gear of differential)	Hexagon waf = 15 mm	97	77 Nm
- Screw plug (converter bell)	Hexagon socket waf = 8 mm	98	45 Nm
- Hexagon bolt (converter bell)	Hexagon waf = 13 mm	102	23 Nm
- Hexagon bolt (input shaft left)	Hexagon waf = 13 mm	104	23 Nm
- Cylindrical bolt (tube)	TORX-TX 27	106	5 Nm
- Cylindrical bolt (control unit)	TORX-TX 27	108	8 Nm
- Hexagon bolt (oil pan)	Hexagon waf = 10 mm	110	6 Nm
- Screw plug (oil pan)	Hexagon socket waf = 12 mm	110	80 Nm
- Cylindrical bolt (cover of oil strainer)	TORX-TX 27	111	8 Nm



PREFACE

The following troubleshooting table for the ZF 4 HP 14/18 automatic transmission is intended to be an aid in determining a diagnosis.

The faults listed have been written in the form in which they are generally presented by customers. The description which you are given may vary from this and it is up to the Service Engineer to interpret it accordingly.

If complaints are received regarding troublesome leaks, we recommend determining exactly where the leak is occurring before starting the job of sealing. There are suitable crack testing agents available such as

Met-L-Chek

This product is available from the trade in spray form and enables the leak point to be precisely located after a short test run.

Operational requirements

- Correct oil level
- Correct adjustment of accelerator cable:
 - Zero load: Lead seal 0,5 mm from sleeve
 - Full throttle: Lead seal 39,0 mm from sleeve
 - Kick-down: Lead seal 43,5 mm from sleeve
- Position indicator ok

Troubleshooting the 4 HP 14/18 automatic transmission

Fault	Possible cause	Remedy
<p>1. Position P</p> <p>1.1 Park position does not engage or slipping</p>	<ul style="list-style-type: none"> - Selector linkage or cable incorrectly adjusted - Clearance at stop plate too large - Segment installed incorrectly - Excessive friction in the parking interlock mechanism 	<ul style="list-style-type: none"> - Correct setting - Correct setting - Install the correct way round - Examine parts (for dirt and burrs); replace if necessary
<p>1.2 Engine does not start</p>	<ul style="list-style-type: none"> - Starter interlock switch faulty - Excessive clearance at selector shaft 	<ul style="list-style-type: none"> - Replace starter interlock switch - Correct setting
<p>2. Position R</p> <p>2.1 No Reverse</p>	<ul style="list-style-type: none"> - Selector linkage or cable between lever and transmission incorrectly adjusted - Oil strainer dirty - Clutch B damaged - Brake D damaged In this case no engine braking action in Pos. 1, 1. gear - Governor jammed (locking valve 1 and Reverse pushed) - Locking valve 1 and Reverse jammed 	<ul style="list-style-type: none"> - Correct setting - Replace oil strainer - Replace transmission - Replace transmission - Replace governor cpl. or control unit - Replace control unit
<p>2.2 Slipping or vibration when moving off</p>	<ul style="list-style-type: none"> - Clutch B or brake D damaged - Leak in oil feed of clutch B (rectangular rings on intermediate plate) 	<ul style="list-style-type: none"> - Replace transmission - Replace transmission

Troubleshooting the 4 HP 14/18 automatic transmission

Fault	Possible cause	Remedy
<p>2.3 Hard engaging jerk P-R or N-R Double jerk when engaging from P-R or N-R n_{eng} 1500 rpm</p>	<ul style="list-style-type: none"> - Damper D faulty In this case shift pos. 2-1 not ok 	<ul style="list-style-type: none"> - Replace control unit
<p>2.4 Reversing lamp does not come on, electrics ok</p>	<ul style="list-style-type: none"> - Starter interlock switch faulty 	<ul style="list-style-type: none"> - Replace starter interlock switch
<p>3.1 Position N Engine does not start</p>	<ul style="list-style-type: none"> - Starter interlock switch faulty 	<ul style="list-style-type: none"> - Replace starter interlock switch
<p>3.2 Vehicle moves or creeps forward</p>	<ul style="list-style-type: none"> - Selector linkage or cable between selector lever and transmission incorrectly adjusted 	<ul style="list-style-type: none"> - Correct setting
<p>4. Position D 4.1 No power</p>	<ul style="list-style-type: none"> - Converter relief valve open - Oil strainer dirty - Clutch A faulty - 1. gear freewheel slipping - Selector linkage or cable incorrectly adjusted - Cable valve 3-4 jammed 	<ul style="list-style-type: none"> - Replace transmission - Replace oil strainer - Replace transmission - Replace transmission - Correct setting - Replace control unit

Troubleshooting the 4 HP 14/18 automatic transmission

Fault	Possible cause	Remedy
4.2 Slipping or vibration when moving off	<ul style="list-style-type: none"> - Clutch A damaged - Rectangular ring or O-ring on turbine shaft damaged (seal of oil feed of clutch A) - or O-rings of piston A damaged (also 4 HP 14) 	<ul style="list-style-type: none"> - Replace transmission - Replace transmission
4.3 Hard engaging jerk N-D (n_{eng} 1500 rpm)	<ul style="list-style-type: none"> - Damper A jammed or spring broken - Clutch A damaged - Leak at ball of cable 3-4 	<ul style="list-style-type: none"> - Replace control unit - Replace transmission - Replace control unit
4.4 No gearshift (whether cold or warm) <ul style="list-style-type: none"> - Gearshift 1-2/2-1 - Gearshift 1-2 - Gearshift 2-3/3-2 - Gearshift 2-3 - Gearshift 3-4/4-3 - Gearshift 3-4 	<ul style="list-style-type: none"> - Governor dirty - Selector valve 1-2 jammed - Brake C or C' faulty - Governor jammed - Selector valve 2-3 jammed - Clutch E faulty - Leak at oil feed of clutch E (same as „moves off in 3rd”) Rectangular rings on engine shaft or turbine shaft faulty Check for leaks at protection cap in intermediate plate - Governor dirty - Selector valve 3-4 jammed - Brake C' faulty In this case gearshift 1-2 ok - Brake band C' not pretensioned (nut slackened) - Upshift valve 2-3-4 jammed - Pos. 3 valve jammed 	<ul style="list-style-type: none"> - Replace governor cpl. - Replace control unit - Replace transmission - Replace governor - Replace control unit - Replace transmission - Replace transmission - Replace governor - Replace control unit - Replace transmission - Replace transmission - Replace control unit - Replace control unit

Troubleshooting the 4 HP 14/18 automatic transmission

Fault	Possible cause	Remedy
<p>4.5 Vehicle moves off in 2nd</p> <p>Vehicle moves off in 3rd</p> <p>Vehicle shifts 1-3</p> <p>Vehicle shifts 1-4</p>	<ul style="list-style-type: none"> - Governor bush jammed - Selector valve 1-2 jammed - Brake band over-tightened - Brake band does not release - Middle rectangular ring on governor flange faulty - Governor bush jammed - Selector valve 1-2 and 2-3 jammed - Leak at protective cap in intermediate flange (clutch B constantly filled) - Selector valve 2-3 jammed - 2-3-4 valve jammed - 1-2-3 valve jammed (at face end of 1-2 valve) - Engine cuts out 	<ul style="list-style-type: none"> - Replace governor cpl. - Replace control unit - Correct setting - Replace transmission - Replace transmission - Replace governor cpl. - Replace control unit - Replace transmission - Replace control unit - Replace control unit - Replace control unit - Replace control unit
<p>4.6 Shift speeds</p> <ul style="list-style-type: none"> - Zero load shift not ok - Full load shift points not ok - No kick-down shift 1-2/2-1 2-3/3-2 3-4/4-3 	<ul style="list-style-type: none"> - Governor dirty - Leak in area of governor - Selector valves do not move freely - Accelerator cable not correctly adjusted - Accelerator cable not correctly adjusted - Accelerator cable not correctly adjusted - Accelerator cable not correctly adjusted - Imbalance in governor 	<ul style="list-style-type: none"> - Replace governor cpl. - Replace transmission - Replace control unit - Correct setting - Correct setting - Correct setting - Correct setting - Replace governor

Troubleshooting the 4 HP 14/18 automatic transmission

Fault	Possible cause	Remedy
<p>6. Position 1</p> <p>6.1 Manual down-shift 2-1 not ok</p>	<ul style="list-style-type: none"> - Locking valve of 1st and Reverse does not operate freely - Governor does not operate freely 	<ul style="list-style-type: none"> - Replace control unit - Replace governor cpl.
<p>6.2 No engine braking action</p>	<ul style="list-style-type: none"> - Brake D. damaged 	<ul style="list-style-type: none"> - Replace transmission
<p>7. General faults</p> <p>7.1 Accelerator cable jams</p>	<ul style="list-style-type: none"> - Nipple in accelerator cam slipped out - Excessive friction in sleeve of accelerator cable - Governor pressure plunger jammed 	<ul style="list-style-type: none"> - Insert nipple or replace accelerator cable - Replace accelerator cable - Replace control unit
<p>7.2 After long journey, noises and interruption to positive engagement</p>	<ul style="list-style-type: none"> - Oil strainer at control unit dirty 	<ul style="list-style-type: none"> - Replace oil strainer
<p>7.3 No positive engagement forward or backward, loud noises</p>	<ul style="list-style-type: none"> - Driver plate between converter and engine broken off - Pump driver broken off 	<ul style="list-style-type: none"> - Replace transmission - Replace transmission

Troubleshooting the 4 HP 14/18 automatic transmission

Fault	Possible cause	Remedy
<p>8. Leaks</p> <p>8.1 Oil drips out of converter bell housing</p>	<ul style="list-style-type: none"> - Gasket in converter bell housing damaged - Leak at weld seam of converter 	<ul style="list-style-type: none"> - Replace gasket - Replace converter
<p>8.2 Leak between transmission housing and converter bell housing</p>	<ul style="list-style-type: none"> - Fastening bolts on converter bell housing have loosened 	<ul style="list-style-type: none"> - Tighten bolts
<p>8.3 Leak between transmission housing and oil pan</p>	<ul style="list-style-type: none"> - Fastening bolts on oil pan loosened (oil pan twisted) - Oil pan gasket damaged 	<ul style="list-style-type: none"> - Tighten bolts or replace oil pan - Replace gasket
<p>8.4 Leak between transmission housing and side cover</p>	<ul style="list-style-type: none"> - Fastening bolts slackened 	<ul style="list-style-type: none"> - Tighten bolts
<p>8.5 Leak at oil cooler</p>	<ul style="list-style-type: none"> - Screw connection loose - Gasket damaged - Leak at cooler 	<ul style="list-style-type: none"> - Tighten bolt - Replace gasket - Replace cooler
<p>8.6 Leak at cover of brake C'</p>	<ul style="list-style-type: none"> - Outer O-Ring damaged (cover C') 	<ul style="list-style-type: none"> - Replace O-ring

Troubleshooting the 4 HP 14/18 automatic transmission

Fault	Possible cause	Remedy
8.7 Leak adjusting bolt of brake band C'	<ul style="list-style-type: none"> - O-ring at pin damaged 	<ul style="list-style-type: none"> - Replace O-ring (control unit has to be removed)
8.8 Leak at retaining bolts for bearing ring of side shaft	<ul style="list-style-type: none"> - Bolts slackened - Seals damaged - Does not apply to 4 HP 18 	<ul style="list-style-type: none"> - Tighten bolts - Replace seals
8.9 Loss of oil at accelerator cable connector	<ul style="list-style-type: none"> - O-ring on connector damaged 	<ul style="list-style-type: none"> - Replace O-ring; also accelerator cable, if necessary
8.10 Leak at differential	<ul style="list-style-type: none"> - Shaft seals at the input shafts damaged 	<ul style="list-style-type: none"> - Replace shaft seals
8.11 Leak at differential extension	<ul style="list-style-type: none"> - O-ring damaged - Bolts slackened 	<ul style="list-style-type: none"> - Replace O-ring - Tighten bolts
8.12 Leak at speedometer	<ul style="list-style-type: none"> - O-ring in speedometer sleeve damaged - Shaft seal in speedometer sleeve damaged 	<ul style="list-style-type: none"> - Replace O-ring - Renew speedometer sleeve cpl.

Troubleshooting the 4 HP 14/18 automatic transmission

Fault	Possible cause	Remedy
8.13 Leak at breather	<ul style="list-style-type: none"> - Oil level too high (severe foaming) - Wrong grade of oil 	<ul style="list-style-type: none"> - Correct oil level - Replace transmission
8.14 Leak at selector shaft	<ul style="list-style-type: none"> - Shaft seal damaged 	<ul style="list-style-type: none"> - Replace shaft seal
9. Noises 9.1 Noises in all positions Intake noises from oil pump	<ul style="list-style-type: none"> - Oil level too low - Leak at control unit - Oil strainer blocked 	<ul style="list-style-type: none"> - Correct oil level - Replace control unit - Replace oil strainer
9.2 Noises varying according to speed	<ul style="list-style-type: none"> - Bearing setting of spur gear drive has altered or incorrectly adjusted - Bearing setting of differential has altered or incorrectly adjusted 	<ul style="list-style-type: none"> - Replace transmission - Replace transmission

1.7. Examination of transmission

The following points should be examined:

Correct oil level

Always check the oil level when the engine is running (idling speed) in Position P. It is only possible to determine the correct oil level when the transmission is warm (80°C). It should then be between the Min. and Max. marks.

Oil level too low

This results in engine overrevving in curves, in inclusions of air which produce valve chatter and in general operational faults.

Oil level too high

Risk of severe losses due to churning; foaming; severe increase in temperature when driving hard. Loss of oil through the breather.

Engine correctly tuned

Engine idling at correct speed. Pay attention to the figures given by vehicle manufacturer.

Positive engagement both forward and reverse

Correct adjustment of selector linkage. Pay attention to figures given by vehicle manufacturer.

Stall points

Refer to Group 21 – „Technical Data, Tables, Pressures” of Circular File 401.

Smoothness of gearshifts

Correct adjustment of accelerator cable. Refer to Point 1.6 of „Operational Requirements” on p. 7/1. Correct adjustment of accelerator linkage. Refer to figures given by vehicle manufacturer.



Noises

Refer to Troubleshooting Table, Points 7 and 9.



AVTGR
ВСЕ ДЛЯ АКПП

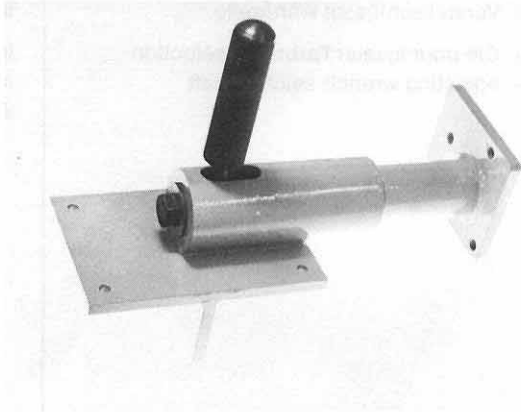
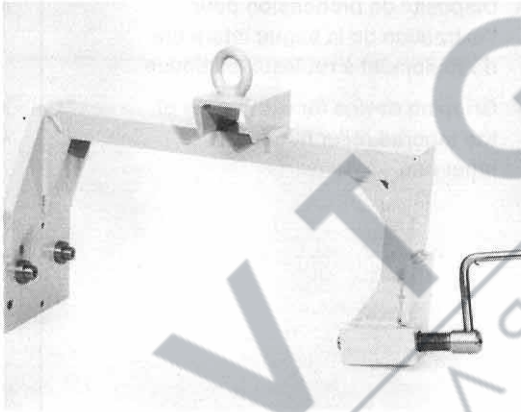

1.8 Spezialwerkzeuge 4 HP 18
Outils spéciaux 4 HP 18
Special Tools 4 HP 18

Bild Nr. Photo No Picture	GEGENSTAND OUTIL TOOL	Bestell-Nr. / Verwendungszweck No de commande / Application Part No / Application	Bemerkungen Observations Remarks
1	<p>84254</p> 	<p>5 X 46 000 244</p> <ul style="list-style-type: none"> - Aufnahmembügel für das komplette Getriebe mit Werkbankhalterung - Support pour la boîte complète avec support d'établi - Transmission work bench holding fixture 	<p>identisch</p> <p>identique</p> <p>identical to 4 HP 14</p>
2	<p>85411</p> 	<p>5 X 46 000 329</p> <ul style="list-style-type: none"> - Spannbügel - Bride de fixation - Clamp 	<p>Mit Aufnahmembügel 5 X 46 000 244 verschraubt</p> <p>Visser avec le support 5 X 46 000 244</p> <p>Screw to the holding fixture 5 X 46 000 244</p>
3	<p>76046</p> 	<p>5 X 56 000 090</p> <ul style="list-style-type: none"> - Wandlerausziehgriffe (2 Stück) - Poignées de dépose/repose du convertisseur - Mounting grips (2) for Removal and to Install Converter 	<p>identisch</p> <p>identique</p> <p>identical to 3 HP 22 4 HP 22 4 HP 14</p>

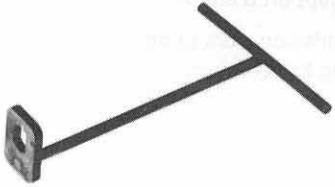
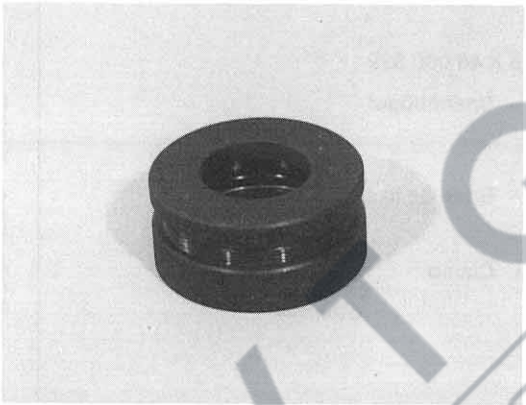

Spezialwerkzeuge 4 HP 18
Outils spéciaux 4 HP 18
Special Tools 4 HP 18

Bild Nr. Photo No Picture	GEGENSTAND OUTIL TOOL	Bestell-Nr. / Verwendungszweck No de commande / Application Part No / Application	Bemerkungen Observations Remarks
4	<p>84278</p> 	<p>5 P 95 000 285</p> <ul style="list-style-type: none"> - Verstell Schlüssel Wählwelle - Clé pour ajuster l'arbre de sélection - adjusting wrench selector shaft 	<p>identisch identique identical to 4 HP 14</p>
5	<p>81 026</p> 	<p>Rollex 48 500</p> <ul style="list-style-type: none"> - Greifstück zum Abziehen des Kegelrollenlager-Innenrings - Dispositif de préhension pour l'extraction de la bague intérieure du roulement à rouleaux coniques - Gripping device for withdrawal of the tapered roller bearing inner ring 	<p>identisch identique identical to 4 HP 14</p>
6	<p>81 028</p> 	<p>Rollex 503 349/S</p> <ul style="list-style-type: none"> - Greifstück zum Abziehen der Kegelrollenlager-Innenringe - Dispositif de préhension pour l'extraction de la bague intérieure du roulement à rouleaux coniques 	<p>identisch identique identical to 3 HP 22 CX</p>

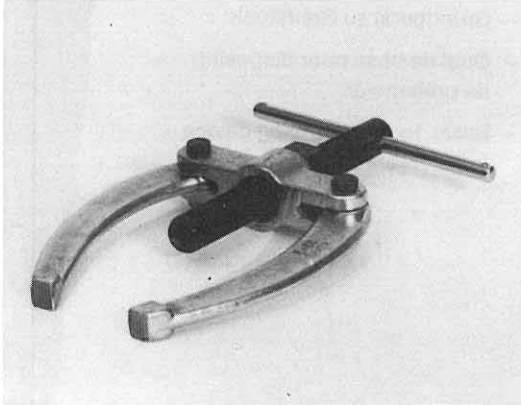

Spezialwerkzeuge 4 HP 18
Outils spéciaux 4 HP 18
Special Tools 4 HP 18

Bild Nr. Photo No Picture	GEGENSTAND OUTIL TOOL	Bestell-Nr. / Verwendungszweck No de commande / Application Part No / Application	Bemerkungen Observations Remarks
7	<p>81 027</p> 	<p>Rollex 1 000 1</p> <ul style="list-style-type: none"> - Grundgerät zu Greifstück - Outil de base pour dispositif de préhension - Basic tool for gripping device 	<p>identisch identique identical to 3 HP 22 CX 4 HP 14</p>
8	<p>85 412</p> 	<p>5 X 46 000 328</p> <ul style="list-style-type: none"> - Auspreßstück für Kegelrollenlager-Innenring - Dispositif d'exprimer pour l'extraction de la bague intérieure du roulement à rouleaux coniques - Squeezing piece for the tapered roller bearing inner ring 	<p>ähnlich similaire similar to 3 HP 14</p>
9	<p>85 413</p> 	<p>Kukko Gr. 21/8</p> <ul style="list-style-type: none"> - Innenauszieher für Kegelrollenlager-Außenringe - Arrache-moyeu intérieur pour bague extérieure du roulement à rouleaux coniques - Internal extractor for outer rings of tapered roller bearings 	<p>ähnlich similaire similar to 4 HP 14</p>

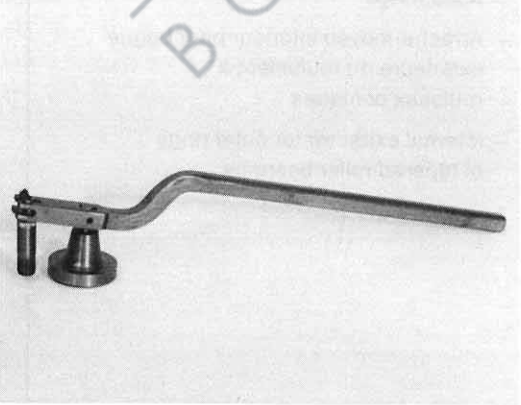

Spezialwerkzeuge 4 HP 18
Outils spéciaux 4 HP 18
Special Tools 4 HP 18

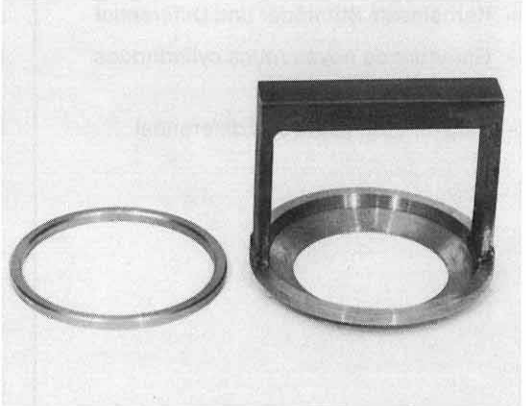
Bild Nr. Photo No Picture	GEGENSTAND OUTIL TOOL	Bestell-Nr. / Verwendungszweck No de commande / Application Part No / Application	Bemerkungen Observations Remarks
10	<p>85414</p> 	<p>Kukko Gr. 22/2</p> <ul style="list-style-type: none"> - Gegenstütze für Innenauszieher - Contre-plaque pour arrachemoyeu interieur - Counter support for internal extractor 	<p>identisch identique</p> <p>identical to 3 HP 22 CX 4 HP 14</p>
11	<p>84256</p> 	<p>5 X 46 000 155</p> <ul style="list-style-type: none"> - Nutmutterschlüssel - Clef d'écrou cannelé - Slotted nut insert 	<p>identisch identique</p> <p>identical to 4 HP 14</p>
12	<p>85415</p> 	<p>5 X 46 000 273</p> <ul style="list-style-type: none"> - Montagevorrichtung für Bremse C' - Montage pour frein C' - Mounting device for brake C' 	

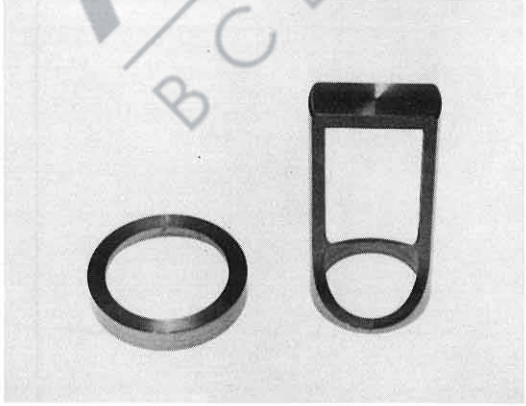
Spezialwerkzeuge 4 HP 18
Outils spéciaux 4 HP 18
Special Tools 4 HP 18

Bild Nr. Photo No Picture	GEGENSTAND OUTIL TOOL	Bestell-Nr. / Verwendungszweck No de commande / Application Part No / Application	Bemerkungen Observations Remarks
13	<p>85417</p> 	<p>5 X 46 000 221</p> <ul style="list-style-type: none"> - Montagevorrichtung für Tellerfeder Kupplung B - Montage pour ressort à disques embrayage B - Mounting device for plate spring clutch B 	<p>ähnlich</p> <p>similaire</p> <p>similar to 4 HP 14</p>
14	<p>84258</p> 	<p>5 X 46 000 167 (teilweise)</p> <ul style="list-style-type: none"> - Montagehilfe - Aide pour montage - Mounting assistance 	<p>identisch</p> <p>identique</p> <p>identical to 4 HP 22 4 HP 14</p>
15	<p>84260</p> 	<p>5 X 46 000 148</p> <ul style="list-style-type: none"> - Montagevorrichtung für Tellerfeder Kupplung E - Montage pour ressort à disques embrayage E - Mounting device for plate spring clutch E 	<p>identisch</p> <p>identique</p> <p>identical to 4 HP 14</p>

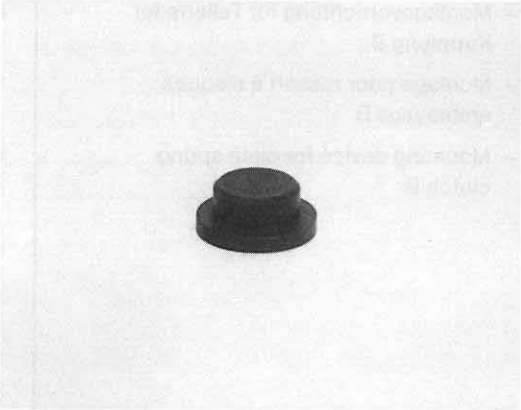
Spezialwerkzeuge 4 HP 18
Outils spéciaux 4 HP 18
Special Tools 4 HP 18

Bild Nr. Photo No Picture	GEGENSTAND OUTIL TOOL	Bestell-Nr. / Verwendungszweck No de commande / Application Part No / Application	Bemerkungen Observations Remarks
16	<p>85418</p> 	<p>5 X 46 000 297</p> <ul style="list-style-type: none"> - Kerneinsatz Stirnräder und Differential - Garniture de noyau roues cylindriques et différentiel - Plug for spur gears and differential 	<p>identisch identique identical to 4 HP 14</p>
17	<p>85419</p> 	<p>5 X 46 000 305</p> <ul style="list-style-type: none"> - Schraubhilfe für Differential - Aide à visserle différentiel - Assistance to screw the differential 	

Spezialwerkzeuge 4 HP 18
Outils spéciaux 4 HP 18
Special Tools 4 HP 18

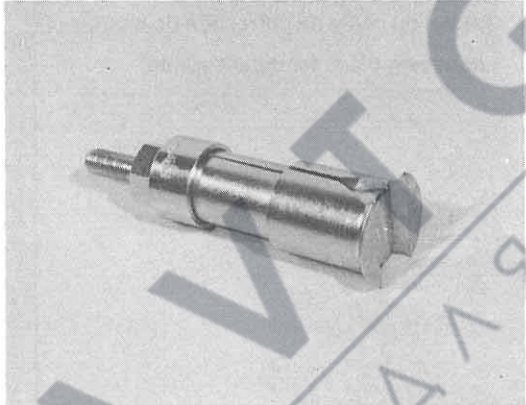
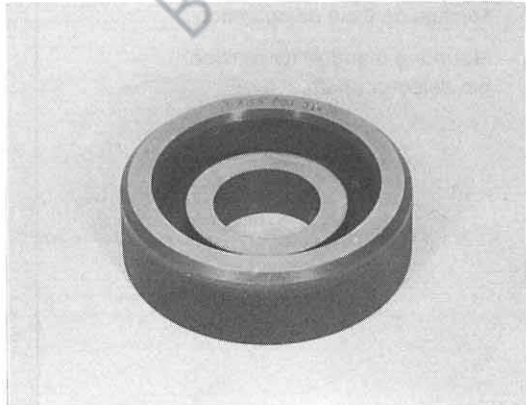
Bild Nr. Photo No Picture	GEGENSTAND OUTIL TOOL	Bestell-Nr. / Verwendungszweck No de commande / Application Part No / Application	Bemerkungen Observations Remarks
18	<p>85 420</p> 	<p>Rollex 300 849</p> <ul style="list-style-type: none"> - Greifstück zum Abziehen des Kegelrollenlager-Innenrings - Dispositif de préhension pour l'extraction de la bague intérieure du roulement à rouleaux coniques - Gripping device for withdrawal of the tapered roller bearing inner ring 	<p>ähnlich similaire similar to 4 HP 14</p>
19	<p>81 025</p> 	<p>Kukko Gr. 21/7</p> <ul style="list-style-type: none"> - Innenauszieher für Kegelrollenlager-Außenringe - Arrache-moyeu intérieur pour bague extérieure du roulement à rouleaux coniques - Internal extractor for outer rings of tapered roller bearings 	<p>identisch identique identical to 4 HP 14</p>
20	<p>85 422</p> 	<p>5 X 46 000 314</p> <ul style="list-style-type: none"> - Montagevorrichtung für Kugellager - Montage pour roulement à billes - Mounting device for ball bearing 	

Spezialwerkzeuge 4 HP 18
Outils spéciaux 4 HP 18
Special Tools 4 HP 18

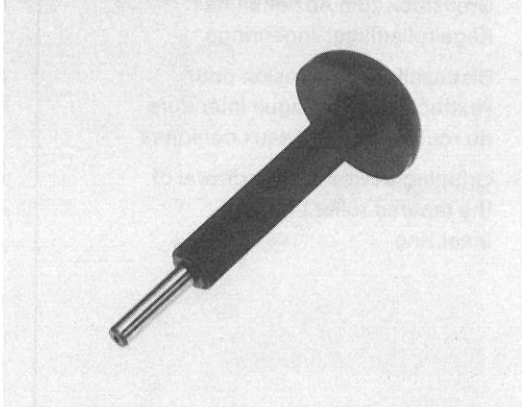
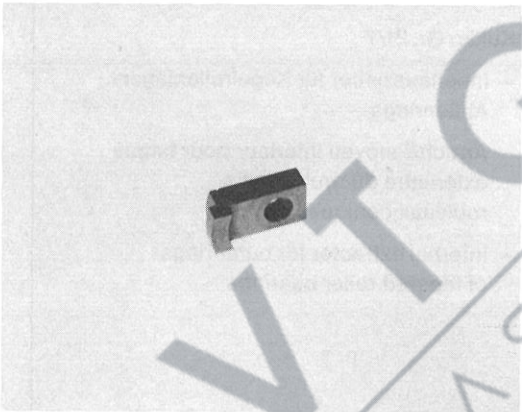
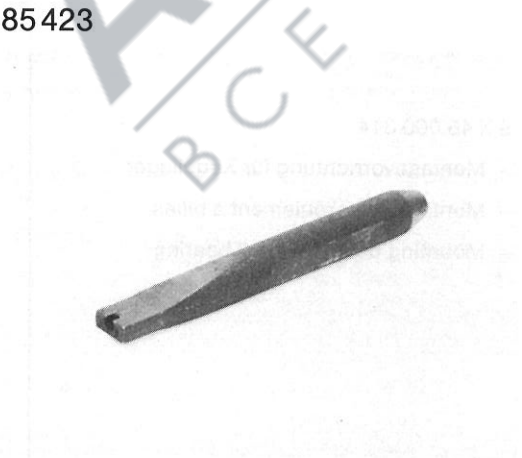
Bild Nr. Photo No Picture	GEGENSTAND OUTIL TOOL	Bestell-Nr. / Verwendungszweck No de commande / Application Part No / Application	Bemerkungen Observations Remarks
21	<p>84266</p> 	<p>5 X 46 000 187</p> <ul style="list-style-type: none"> - Montagedorn WDR Wählwelle - Boulon de montage joint spri de l'axe de sélection - Mounting mandrel for shaft seal selector shaft 	<p>identisch identique identical to 4 HP 14</p>
22	<p>84274</p> 	<p>5 P 89 002 021</p> <ul style="list-style-type: none"> - Einstellstück für Rastenfeder - Pièce d'ajustage pour ressort de rappel du câble de correction de charge - adjusting piece for detent spring 	<p>ähnlich similaire similar to 4 HP 14</p>
23	<p>85423</p> 	<p>5 X 46 000 291</p> <ul style="list-style-type: none"> - Montagebolzen für Spannhülse Wählwelle - Boulon de montage pour douille de serrage de l'axe de sélection - Mounting mandrel for tension pin selector shaft 	<p>ähnlich similaire similar to 4 HP 14</p>

Spezialwerkzeuge 4 HP 18
Outils spéciaux 4 HP 18
Special Tools 4 HP 18

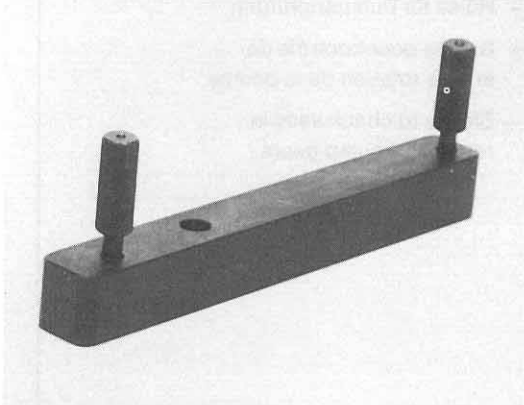
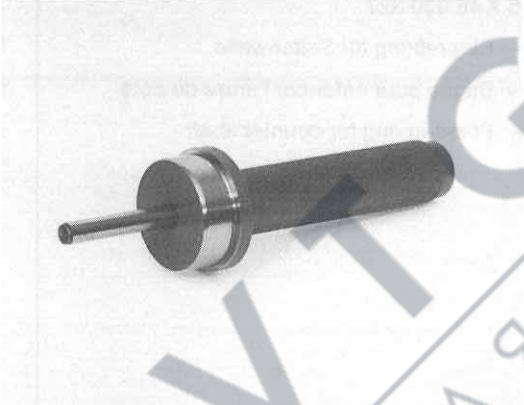
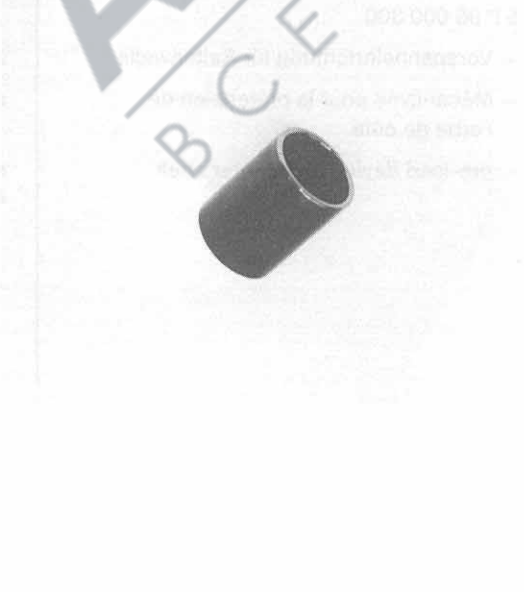
Bild Nr. Photo No Picture	GEGENSTAND OUTIL TOOL	Bestell-Nr. / Verwendungszweck No de commande / Application Part No / Application	Bemerkungen Observations Remarks
24	<p>85424</p> 	<p>5 P 95 000 301</p> <ul style="list-style-type: none"> - Gegenhalter für Rastenscheibe - Contre-appui pour disque à crans - Counter-clamp for stop plate 	<p>ähnlich similaire similar to 4 HP 14</p>
25	<p>85416</p> 	<p>5 X 46 000 267</p> <ul style="list-style-type: none"> - Einschlagdorn für Hülse C' - Manchon pliant pour douille C' - Wrapping mandrel for sleeve C' 	<p>ähnlich similaire similar to 4 HP 14</p>
26	<p>84271</p> 	<p>5 X 46 000 300</p> <ul style="list-style-type: none"> - Montagehülse für Kegelrollenlager-Innenring - Douille de montage pour bague intérieure du roulement à rouleaux coniques - Mounting sleeve for inner ring of tapered roller bearings 	<p>identisch identique identical to 4 HP 14</p>

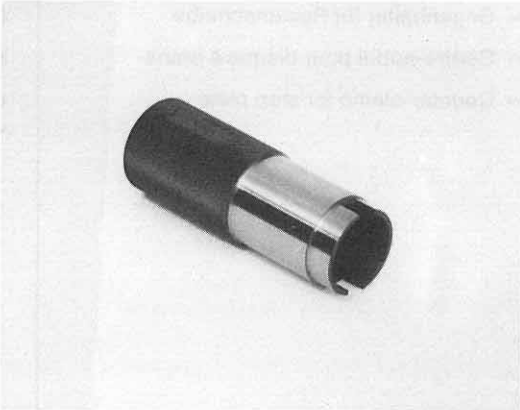
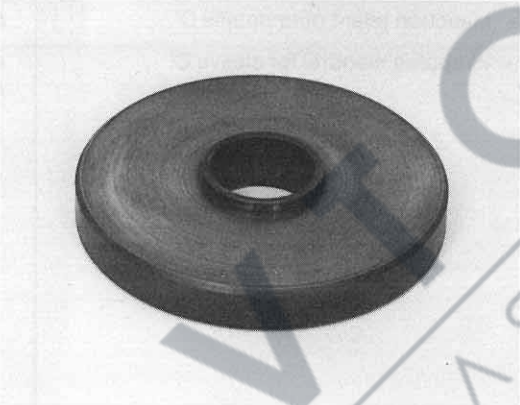
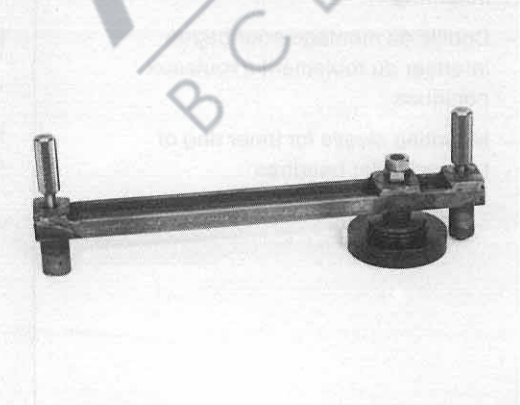

Spezialwerkzeuge 4 HP 18
Outils spéciaux 4 HP 18
Special Tools 4 HP 18

Bild Nr. Photo No Picture	GEGENSTAND OUTIL TOOL	Bestell-Nr. / Verwendungszweck No de commande / Application Part No / Application	Bemerkungen Observations Remarks
27	<p>85 425</p> 	<p>5 X 46 000 306</p> <ul style="list-style-type: none"> - Hülse für Pumpenprüfung - Douille pour contrôle de la libre rotation de la pompe - Sleeve to check easy in rotation of pump gears 	
28	<p>85 426</p> 	<p>5 X 46 000 327</p> <ul style="list-style-type: none"> - Einpreßring für Seitenwelle - Bague pour enfoncer l'arbre de côté - Press-in ring for counter shaft 	<p>ähnlich similaire similar to 4 HP 14</p>
29	<p>85 427</p> 	<p>5 P 95 000 300</p> <ul style="list-style-type: none"> - Vorspanneinrichtung für Seitenwelle - Mécanisme pour la prétension de l'arbre de côté - pre-load device for counter shaft 	<p>ähnlich similaire similar to 4 HP 14</p>

Spezialwerkzeuge 4 HP 18
Outils spéciaux 4 HP 18
Special Tools 4 HP 18

Bild Nr. Photo No Picture	GEGENSTAND OUTIL TOOL	Bestell-Nr. / Verwendungszweck No de commande / Application Part No / Application	Bemerkungen Observations Remarks
30	<p>82177</p> 	<p>5 X 46 000 174</p> <ul style="list-style-type: none"> - Montagehülse für Turm 4. Gang - Douille de montage pour parts 4ième vitesse - Mounting Sleeve for 4.th gear assembly 	<p>identisch identique identical to 4 HP 14</p>
31	<p>85421</p> 	<p>5 X 46 000 369</p> <ul style="list-style-type: none"> - Einpreßstempel für Wellendichtring - Poinçon pour enfoncer le joint à lèvres - Punch to press in the shaft sealing ring 	
32	<p>85428</p> 	<p>5 X 46 000 316</p> <ul style="list-style-type: none"> - Aufpreßvorrichtung für Kegelrollenlager-Außenring - Montage pour engager le bague extérieur du roulement à rouleaux coniques - Mounting device to press on the outer ring of tapered roller bearings 	

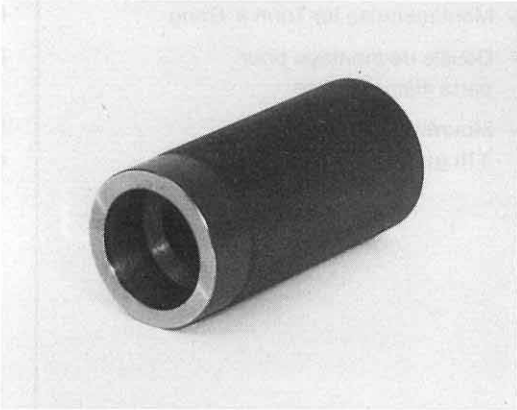
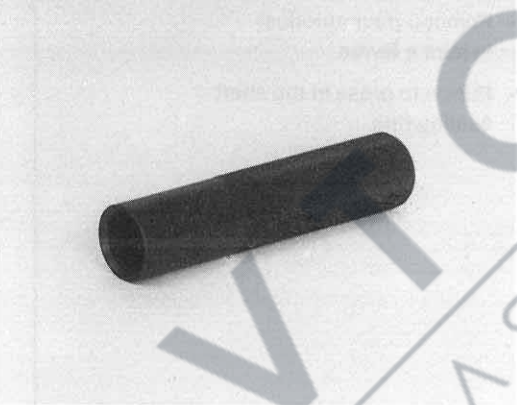
Spezialwerkzeuge 4 HP 18
Outils spéciaux 4 HP 18
Special Tools 4 HP 18

Bild Nr. Photo No Picture	GEGENSTAND OUTIL TOOL	Bestell-Nr. / Verwendungszweck No de commande / Application Part No / Application	Bemerkungen Observations Remarks
33	<p>85431</p> 	<p>5 X 46 000 317</p> <ul style="list-style-type: none"> - Einpreßvorrichtung für Wellendichtring - Montage pour enfoncer le joint à lèvres - Mounting device to press in the shaft sealing ring 	
34	<p>85432</p> 	<p>5 X 46 000 284</p> <ul style="list-style-type: none"> - Montagehülse für Zackenring - Douille de montage pour circlip intérieur - Mounting sleeve for retaining ring 	
35	<p>85430</p> 	<p>5 X 46 000 315</p> <ul style="list-style-type: none"> - Aufpreßvorrichtung für Kugellager - Montage pour engager le roulement à billes - Mounting device to press on the ball bearing 	

Spezialwerkzeuge 4 HP 18
Outils spéciaux 4 HP 18
Special Tools 4 HP 18

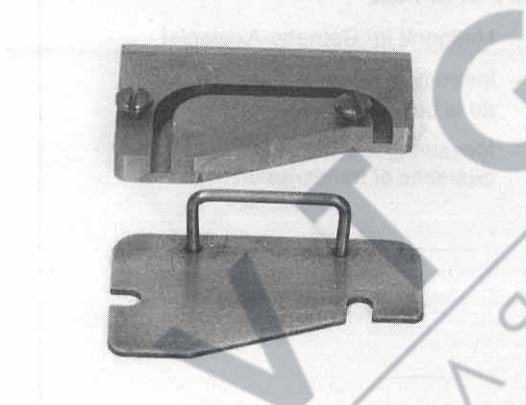
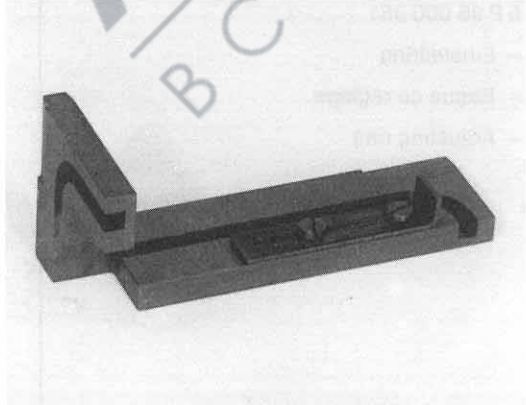
Bild Nr. Photo No Picture	GEGENSTAND OUTIL TOOL	Bestell-Nr. / Verwendungszweck No de commande / Application Part No / Application	Bemerkungen Observations Remarks
36	<p>85 429</p> 	<p>5 X 46 000 368</p> <ul style="list-style-type: none"> - Einpreßvorrichtung für Wellendichtring - Montage pour enfoncer le joint à lèvres - Mounting device to press in the shaft sealing ring 	
37	<p>85 433</p> 	<p>5 X 46 000 279</p> <ul style="list-style-type: none"> - Einpreßhilfe für Ölrohr - Aide pour enfoncer le conduit d'huile - Assistance to press in the oil conduit 	
38	<p>85 434</p> 	<p>5 X 46 000 280</p> <ul style="list-style-type: none"> - Einpreßhilfe für Ölrohr - Aide pour enfoncer le conduit d'huile - Assistance to press in the oil conduit 	

Spezialwerkzeuge 4 HP 18
Outils spéciaux 4 HP 18
Special Tools 4 HP 18

Bild Nr. Photo No Picture	GEGENSTAND OUTIL TOOL	Bestell-Nr. / Verwendungszweck No de commande / Application Part No / Application	Bemerkungen Observations Remarks
39	<p>85 401</p> 	<p>5 X 46 000 352</p> <ul style="list-style-type: none"> - Einpreßhilfe für Rohr - Aide pour enfoncer le tuyau de raccordement - Assistance to press in the connecting piece 	
40	<p>85 435</p> 	<p>5 P 01 001 522</p> <ul style="list-style-type: none"> - Meßgerät für Getriebe-Axialspiel - Instrument mesureur pour jeu axial de la boîte de vitesses - Measuring tool for axial clearance of transmission 	
41	<p>85 436</p> 	<p>5 P 95 000 351</p> <ul style="list-style-type: none"> - Einstellring - Bague de réglage - Adjusting ring 	

Spezialwerkzeuge 4 HP 18
Outils spéciaux 4 HP 18
Special Tools 4 HP 18

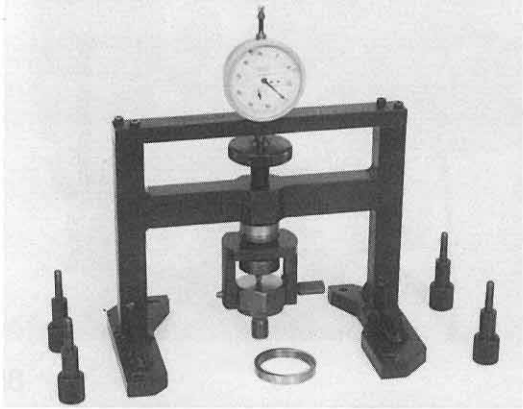
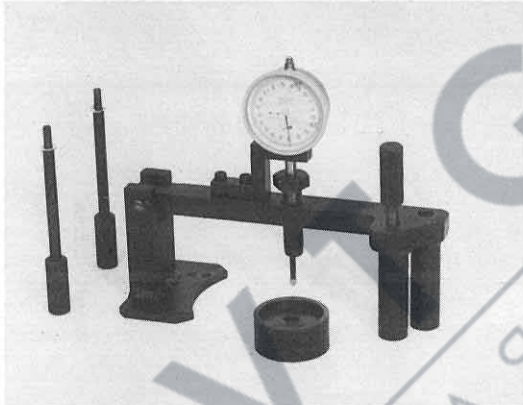
Bild Nr. Photo No Picture	GEGENSTAND OUTIL TOOL	Bestell-Nr. / Verwendungszweck No de commande / Application Part No / Application	Bemerkungen Observations Remarks
42	<p>85 437</p> 	<p>5 P 01 001 458</p> <ul style="list-style-type: none"> - Meßvorrichtung für Lagerspiel - Instrument mesureur pour jeu de palier - Measuring tool for bearing clearance 	
43	<p>85 438</p> 	<p>5 P 01 001 523</p> <ul style="list-style-type: none"> - Meßgerät zur Spieleinstellung Seitenwelle - Instrument mesureur pour ajuster le jeu de l'arbre de renvoi - Measuring tool to adjust the clearance of the counter shaft 	

2. Disassembly

2.1 Disassembling transmission according to components

85 088

Bolt mounting device 5 X 46 000 244 to device 5 X 46 000 329, place transmission in mount and turn it through 180°.

Remove torque converter clamp, if fitted.

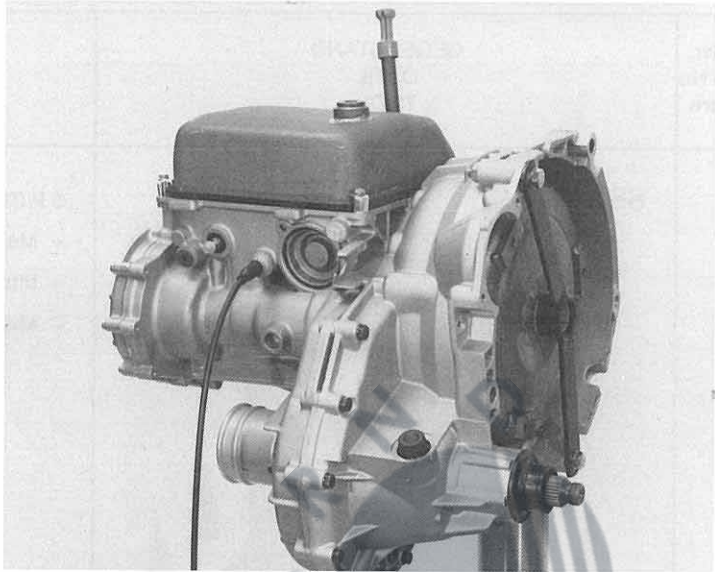

85 089

Use the 2 mounting grips 5 X 56 000 090 to take out the torque converter.

Caution!

- oil flows out
- do not damage the shaft seal of the pump.

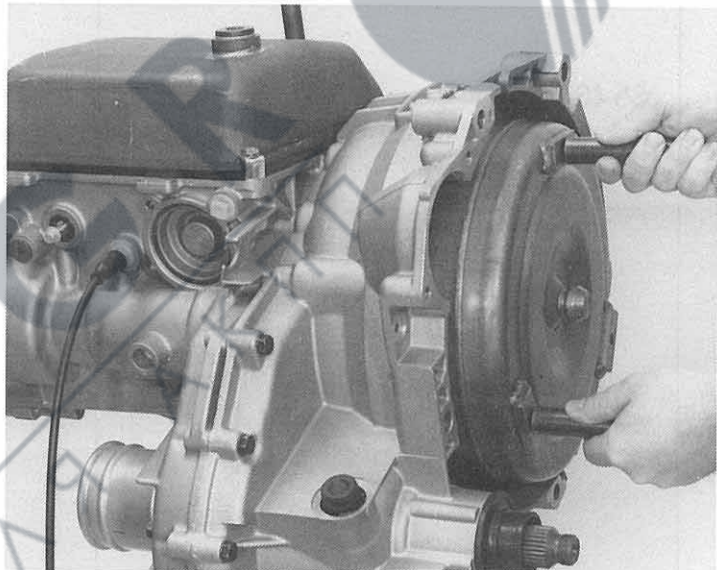

85 090

Turn transmission through 90° and remove the cover with the magnets inserted. This requires slackening 3 cylindrical bolts.

(Width across flats = Torx socket - TX 27).

Take out filter element, turn transmission through 90° and drain oil.

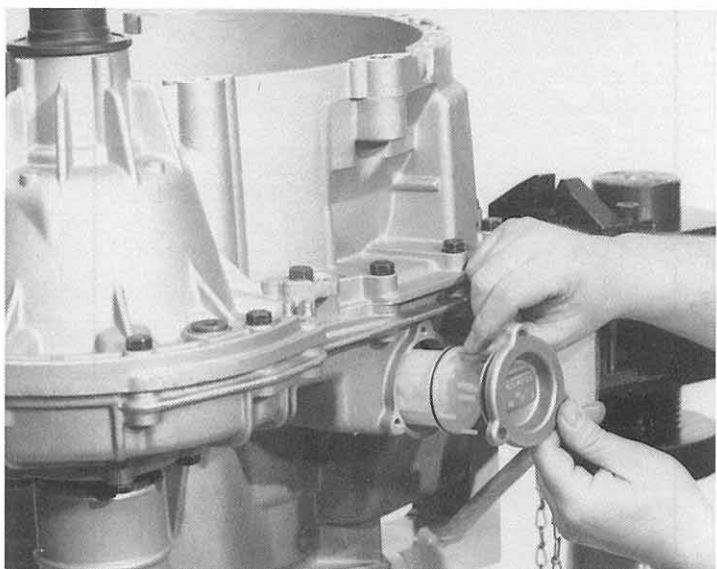

85 091

Withdraw oil dipstick.

Slacken the bolts for fastening the oil pan and take off oil pan together with gasket.

(Width across flats = 10 mm).

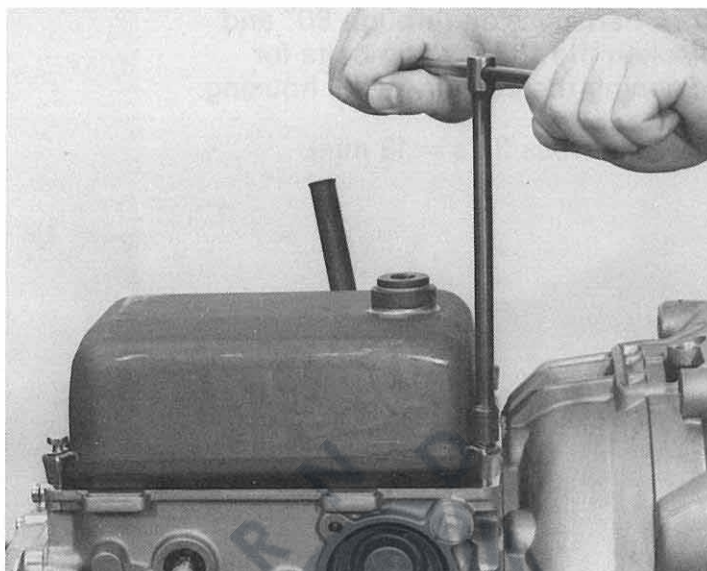

85 092

On the turbo version the tube for the charge air pressure should be levered out using a suitable screwdriver.

(Do not re-use tube or O rings).

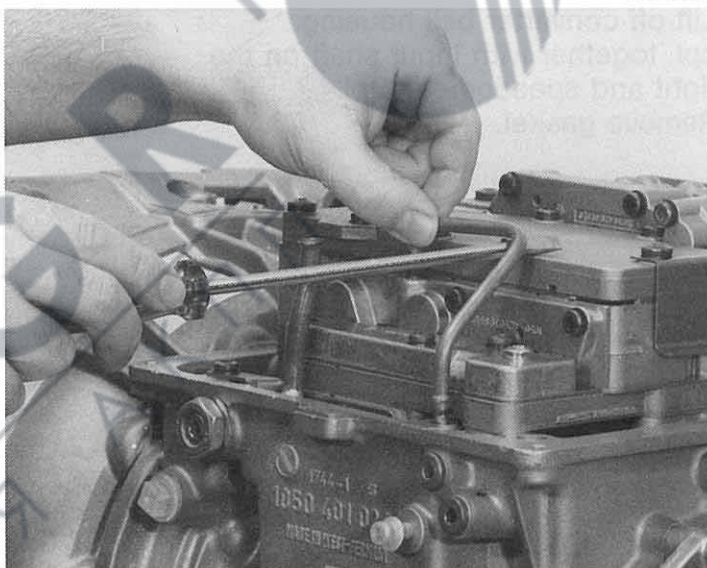

85 093

Slacken the 10 fastening bolts (with thicker head) on the control unit and lift off control unit cpl.

(Width across flats = Torx socket – TX 27).

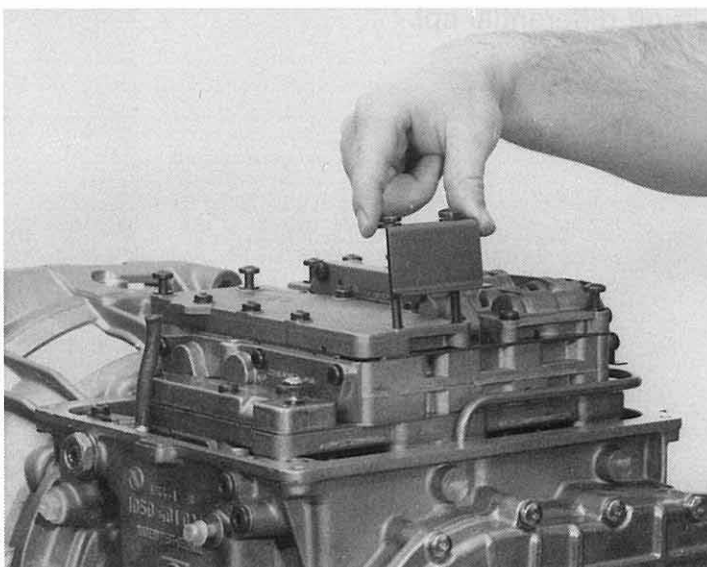

85 094

Turn transmission through 90° and
slacken the 18 hexagon bolts for
fastening the converter bell housing.

(Width across flats = 13 mm).

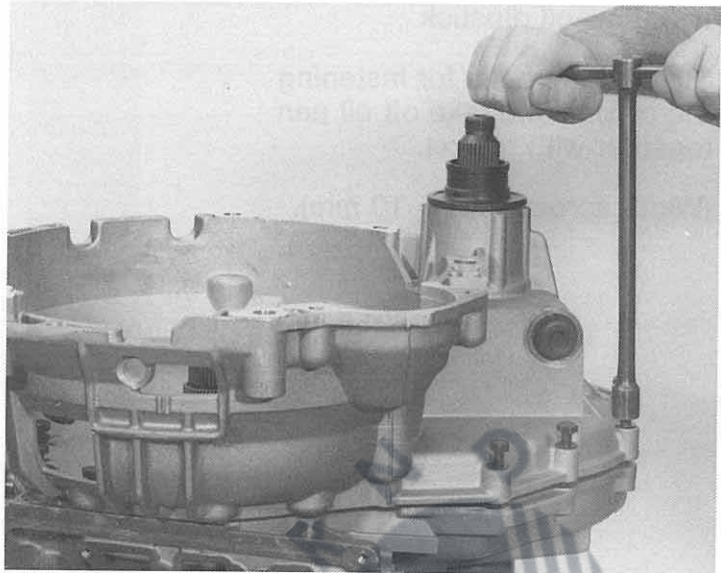

85 095

Lift off converter bell housing
cpl. together with input shaft on the
right and speedometer cpl.
Remove gasket.

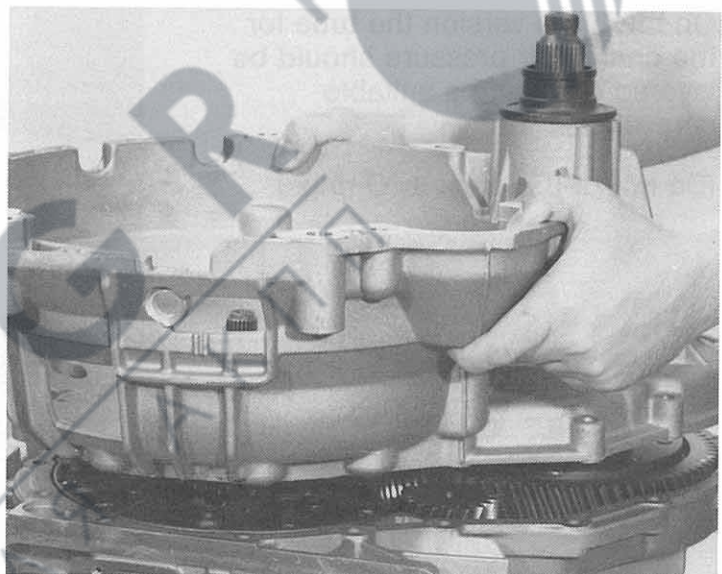

85 096

Lift off differential cpl.

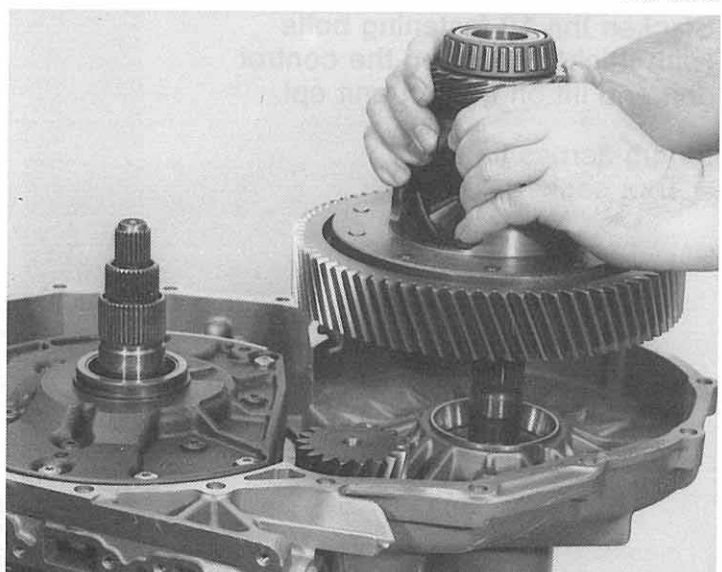

85 097

Take off tappet and compression spring.

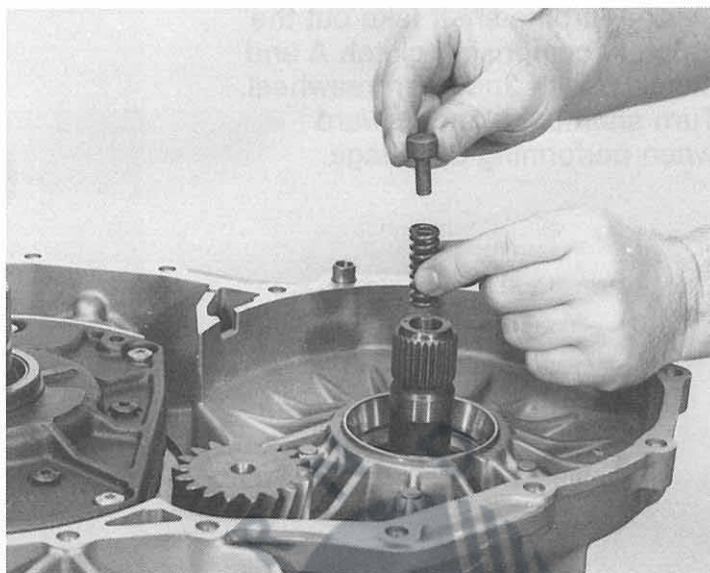

85 098

Unscrew intermediate plate with pump and clutch C. This requires slackening 8 cylindrical bolts of the outer pitch circle.

(Width across flats
= Torx socket – TX 27)

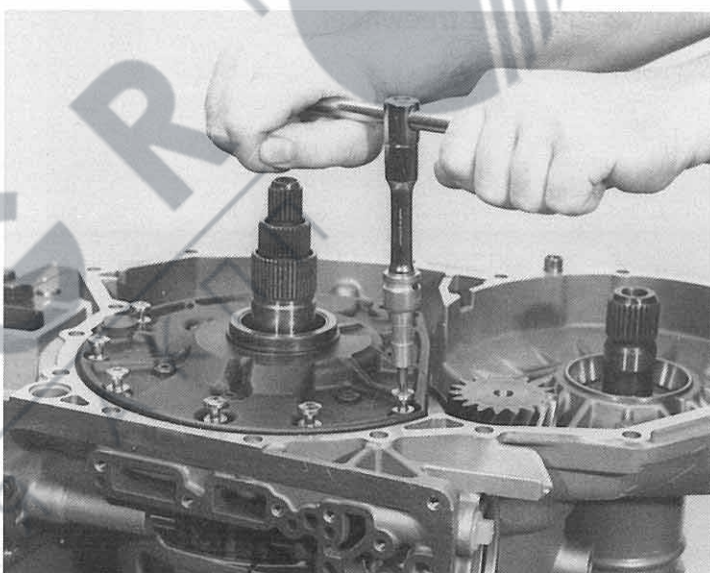

85 099

Caution!

Do not turn over transmission any more.

Remove angle washer and adjusting washer(s).

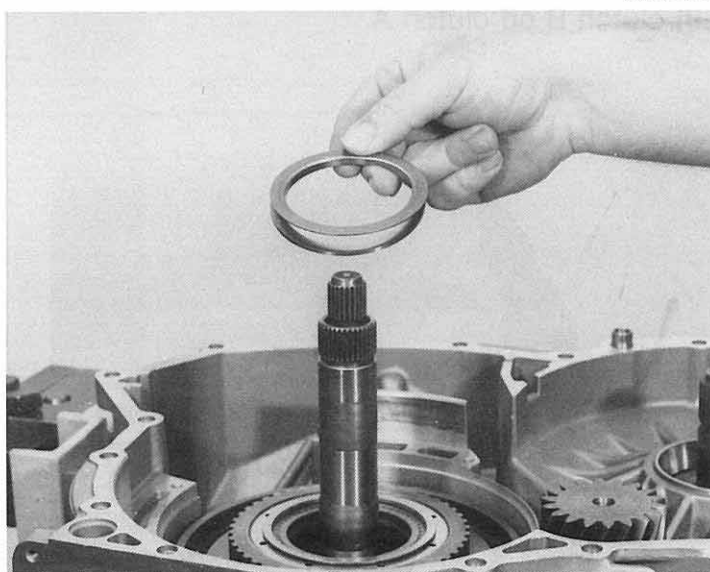

85 100

On the turbine shaft take out the cpl. unit comprising clutch A and clutch B with 2nd gear freewheel. Turn shaft back and forward when performing this stage.

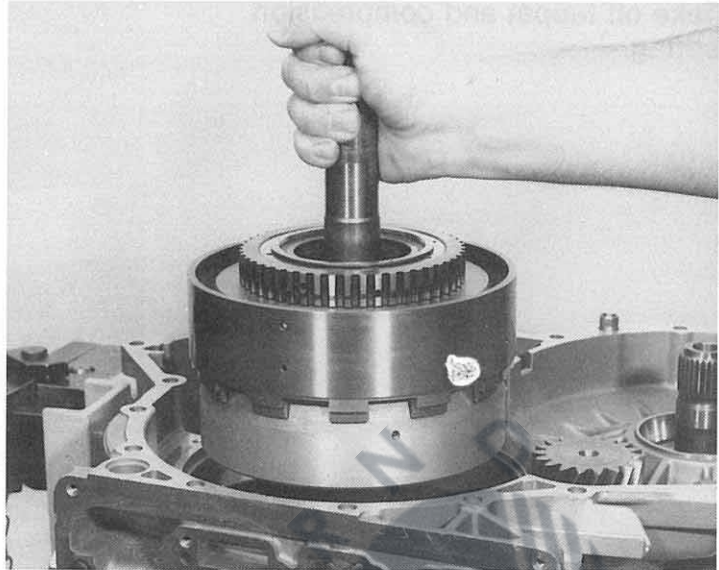

Remove 2nd gear freewheel.

85 101

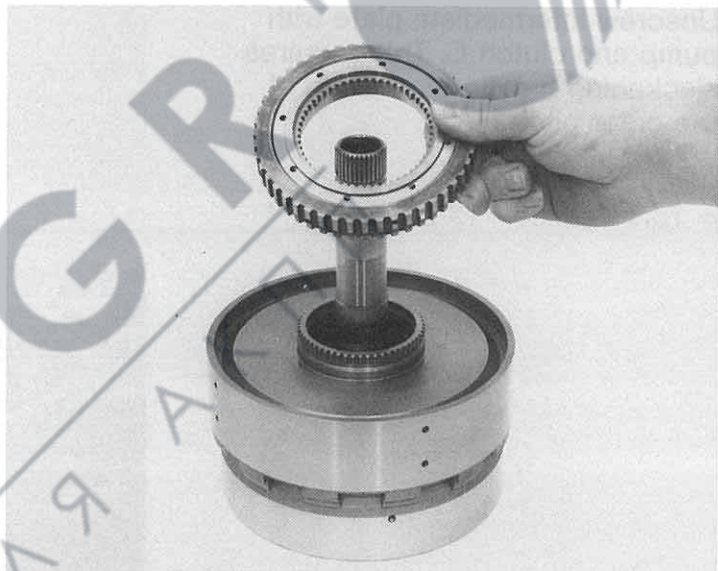

Lift clutch B off clutch A.

85 102

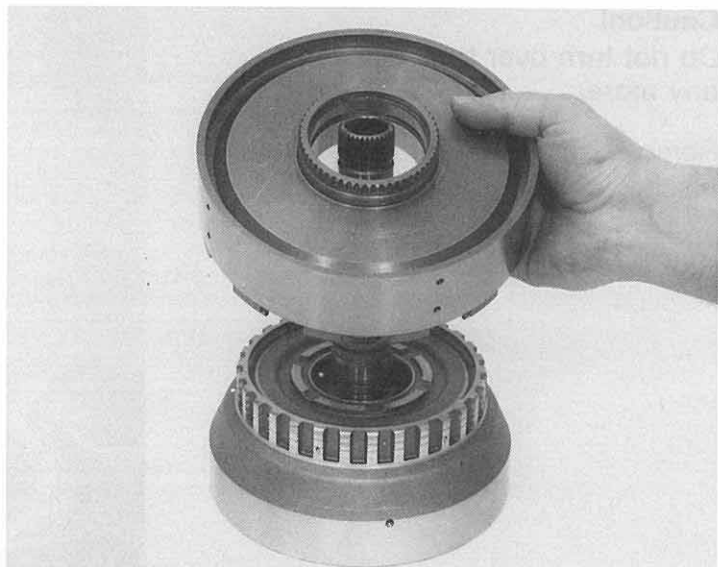

Take out brake band opposite the straps. When removing brake band, ensure it is not bent out.

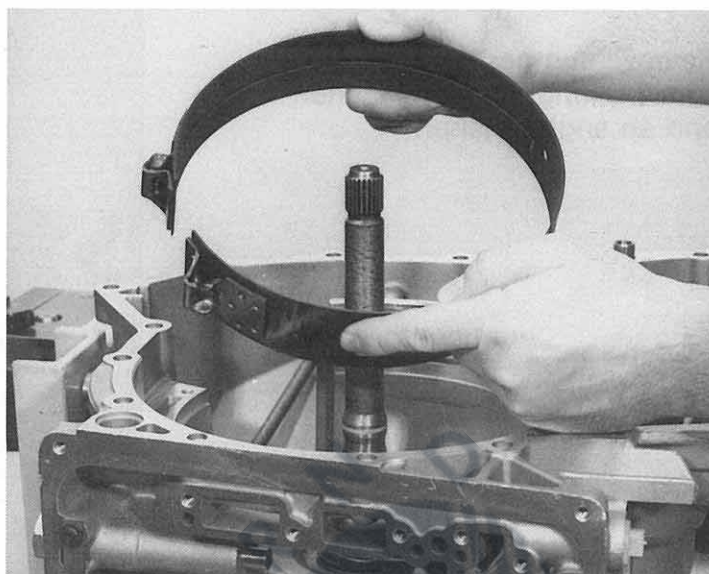

Lift off engine shaft together with clutch E.

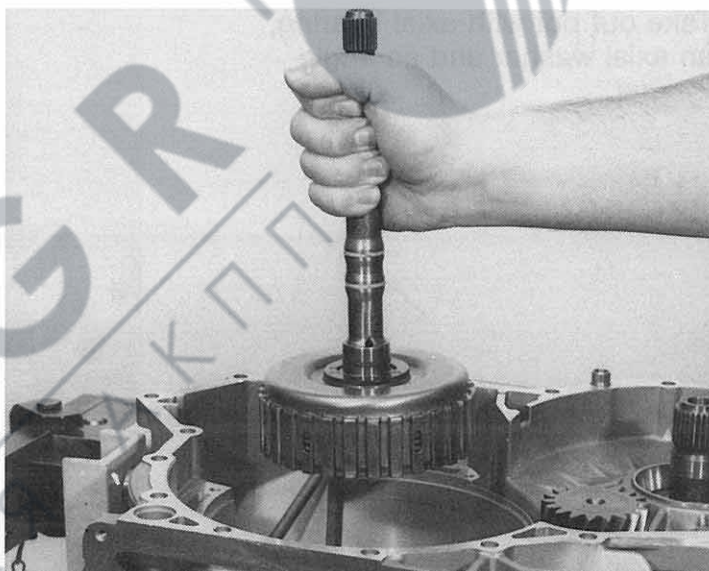

Take out intermediate shaft together with 2 axial washers and an axial needle bearing.

Important!

It is possible that the axial washers remain stuck to the mating face when the axial bearings are removed.

It is recommended to always complete the bearings.

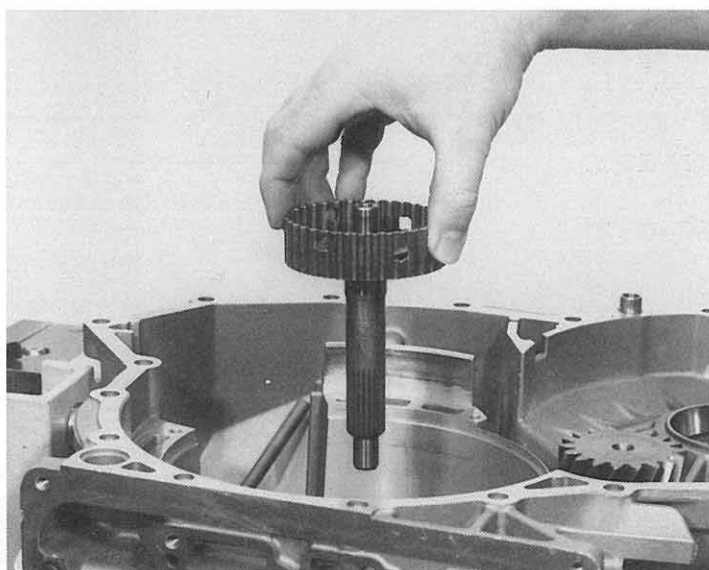

85 106

Remove sun gear shaft cpl. with axial bearing, an axial washer and an angle washer.

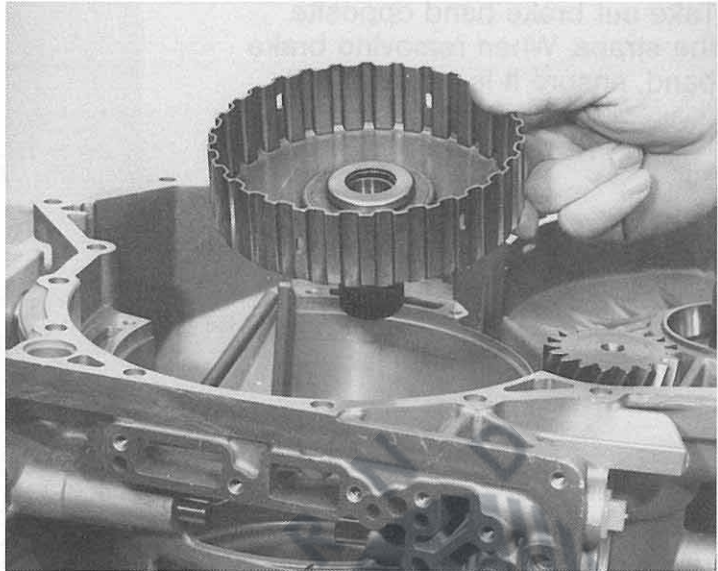

85 107

Take out pot with axial bearing, an axial washer and an angle washer.

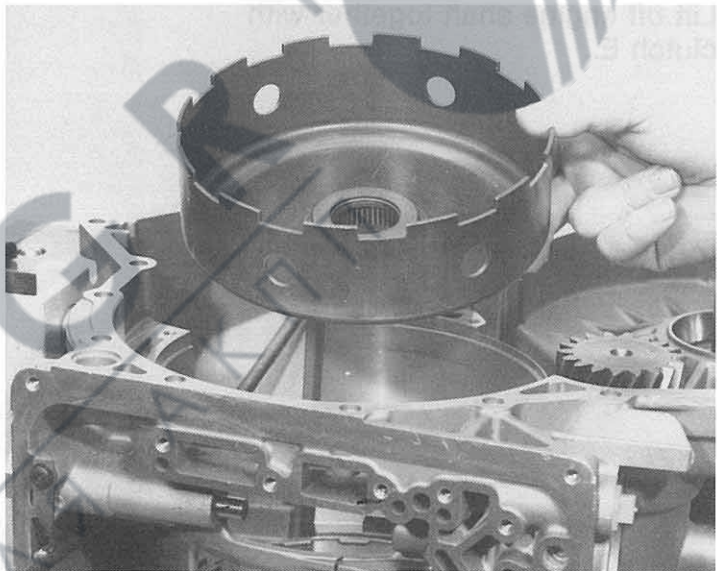

85 108

Lift off sun gear.

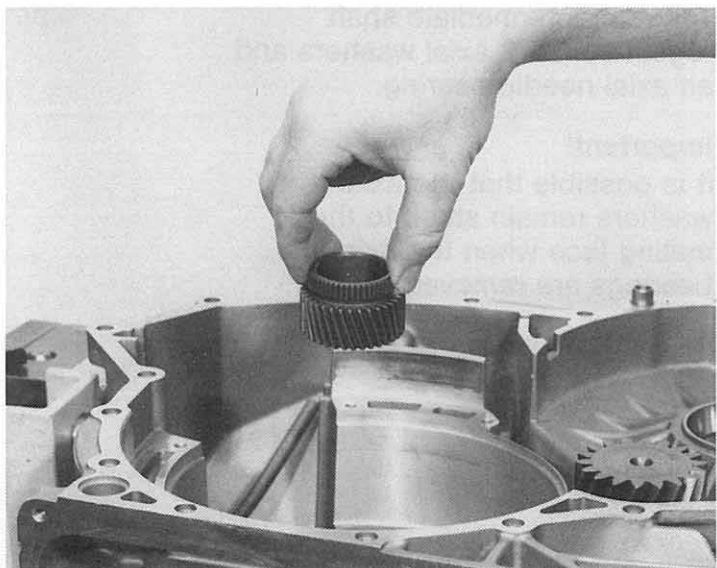

85 109

The planet spider can then be removed cpl. with axial bearing, a washer and an angle washer.

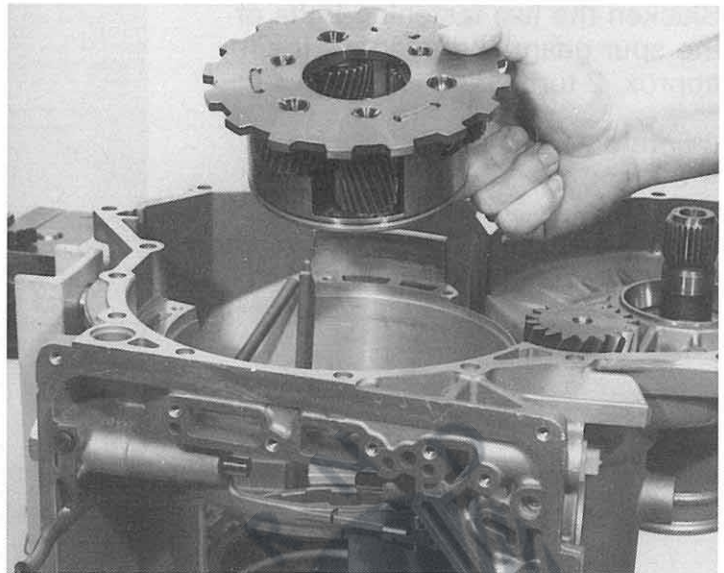

85 110

Turn transmission through 180°. Slacken 13 fastening bolts and remove cover and gasket.

(Width across flats
= Torx socket – TX 27)

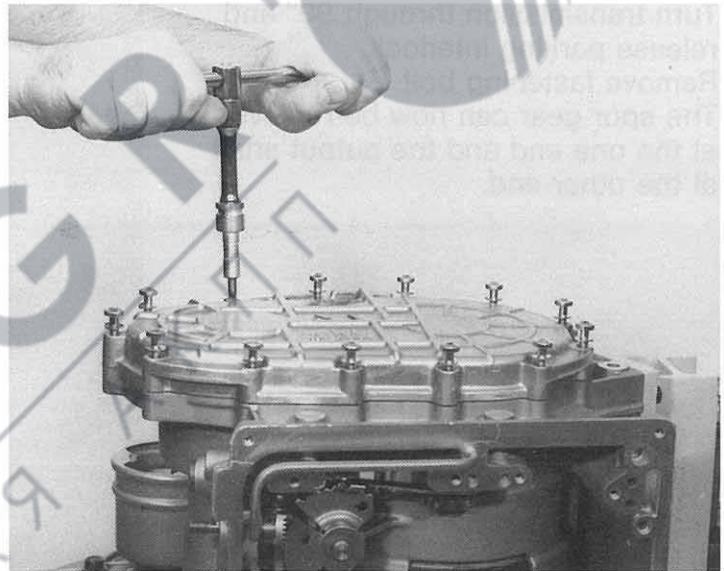

85 111

Engage parking interlock. This is done by setting the position P on the selector shaft with the adjusting wrench 5 P 95 000 285.

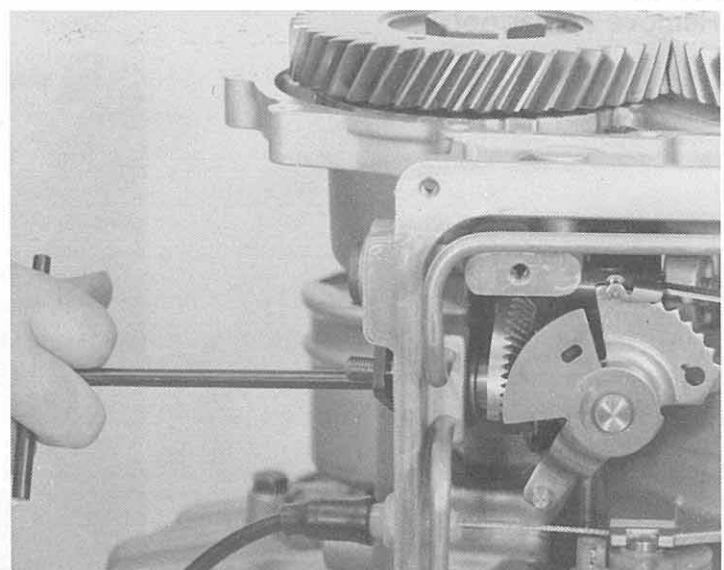

85 112

Slacken the two fastening bolts of the spur gears and unscrew them approx. 2 turns.

(Width across flats of hexagon = 36 mm)

Important!

Do not completely unscrew bolts.

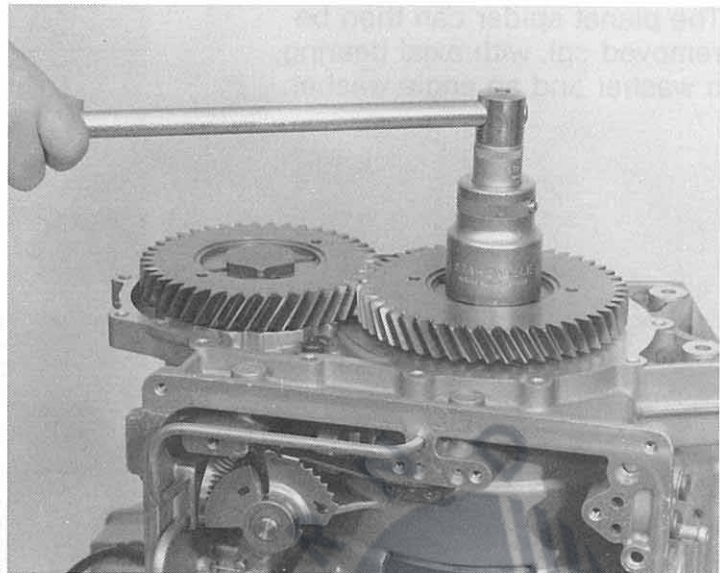

85 113

Turn transmission through 90° and release parking interlock. Remove fastening bolt. The spur gear can now be removed at the one end and the output shaft at the other end.

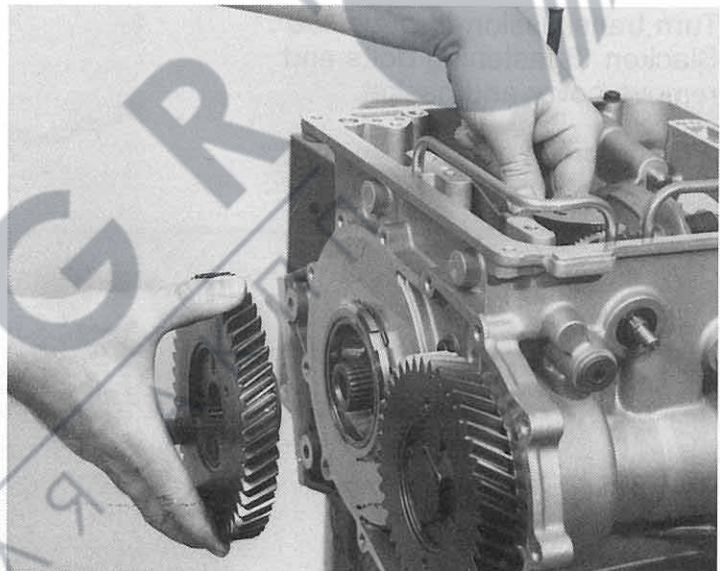

85 114

Remove spider pot.

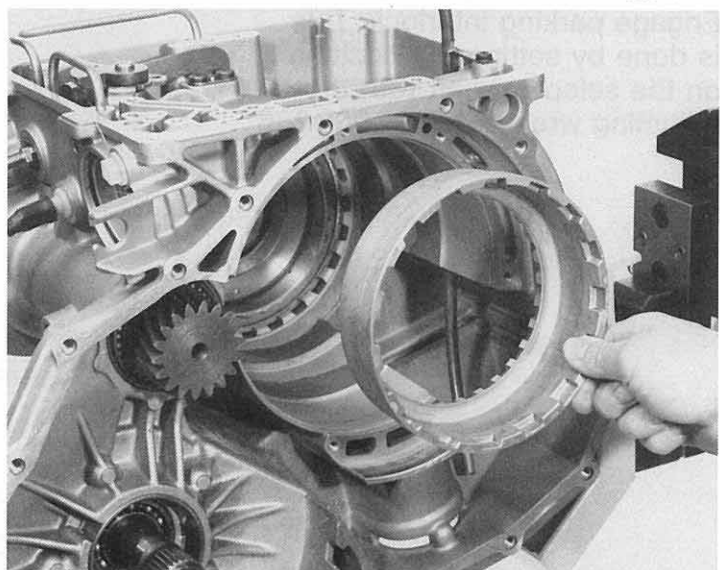

85 115

Completely remove hexagon bolt.
Remove spur gear and adjusting
washer to the one end and counter
shaft to the other side.

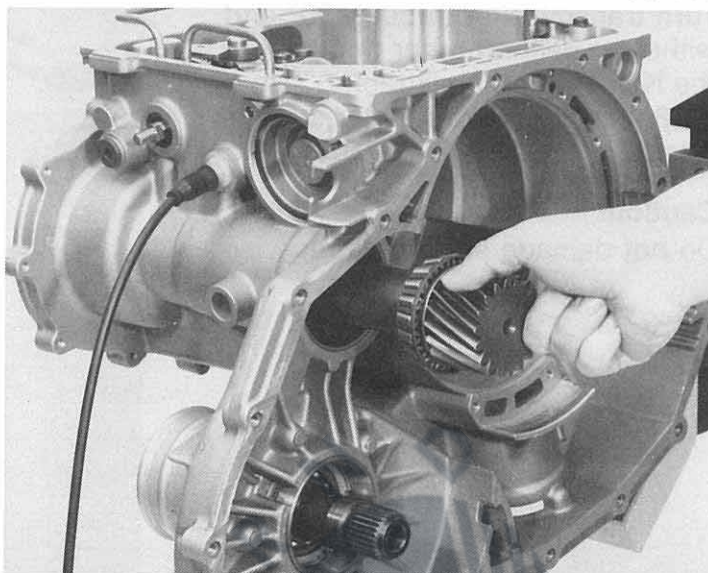

85 116

If necessary, pull the tapered roller bearing inner ring of the spur gear (output shaft) with the Rollex gripper 48.500, screwed into basic tool 1000.1, using the plug 5 X 46 000 297.

Use gripper 503 349/S for the tapered roller bearing inner ring of the spur gear (counter shaft).

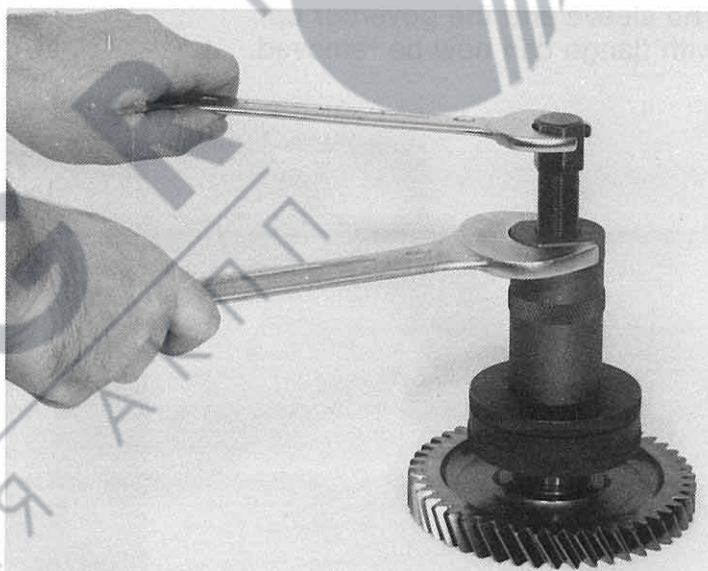

85 117

The tapered roller bearing inner ring on the counter shaft can be removed using the squeezing piece 5 X 46 000 328 under the mandrel press.

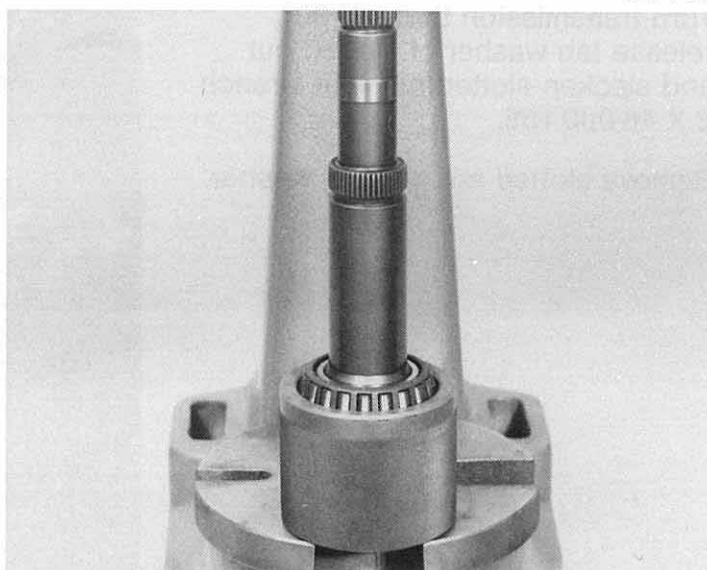

85 118

Turn transmission through 90° and withdraw bearing outer ring with the Kukko internal extractor, size 21/8, screwed into counter support size 22/2.

Caution!

Do not damage sealing surface.

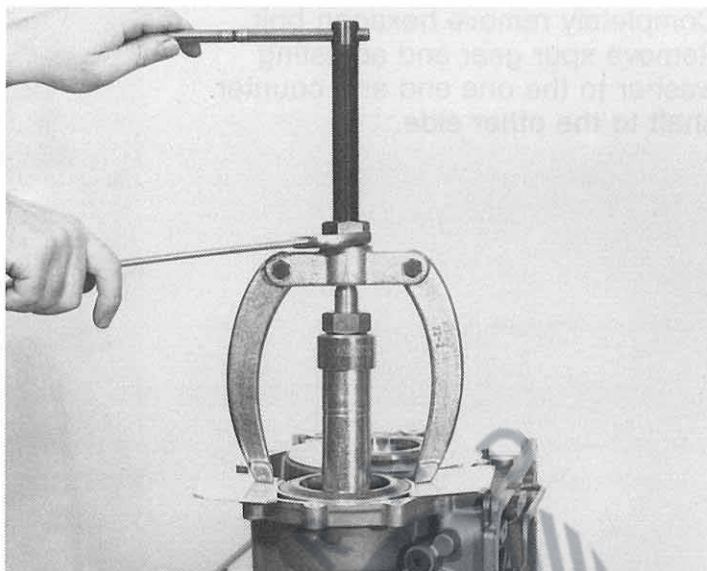

85 119

The sleeve and the governor cpl. with flange can now be removed.

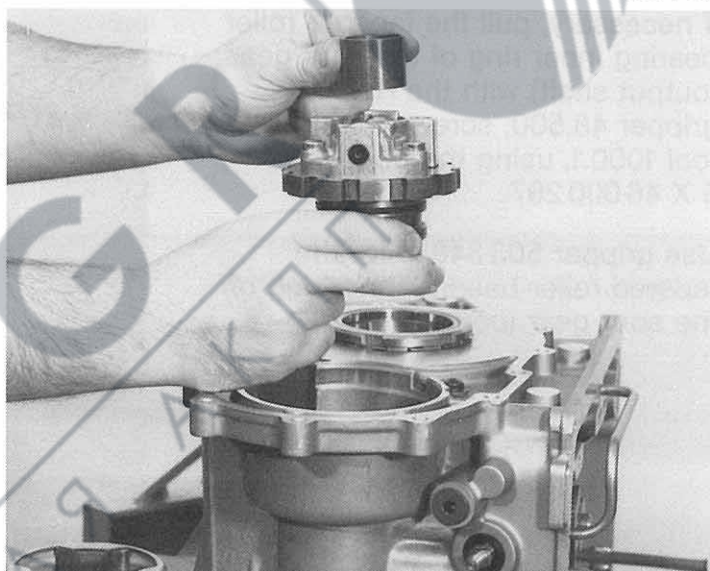

85 120

Turn transmission through 90°, release tab washer of slotted nut and slacken slotted nut with wrench 5 X 46 000 155.

Remove slotted nut and tab washer.

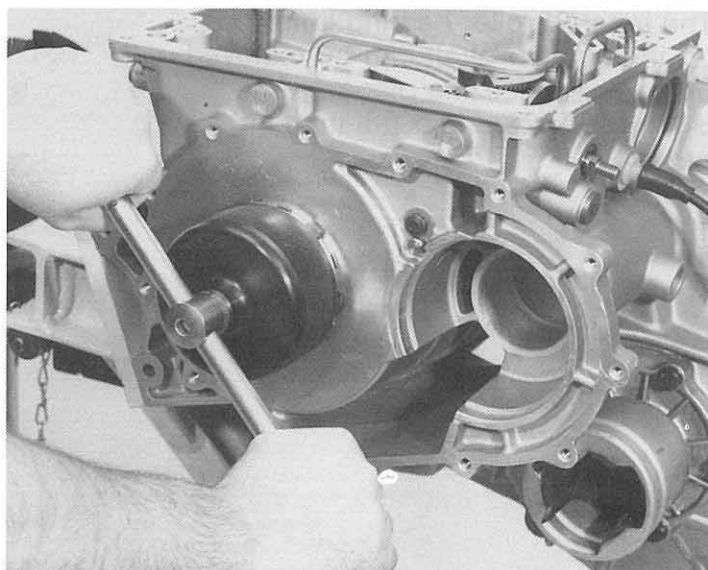

85 121

Bearing ring with 1st gear freewheel cpl. and retaining washer can now be pressed out to the inside.

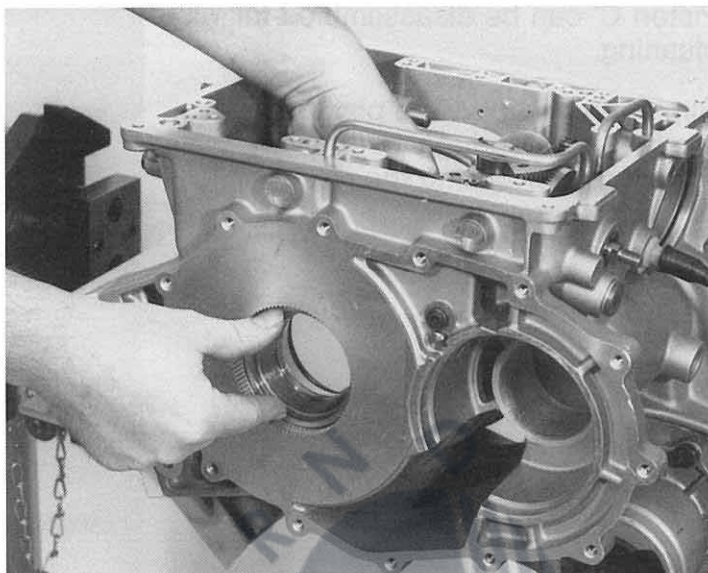

85 122

2.2 Brake C'

Bolt on mounting device 5 X 46 000 273 and press down cover.

The snap ring can now be released using a suitable screwdriver.

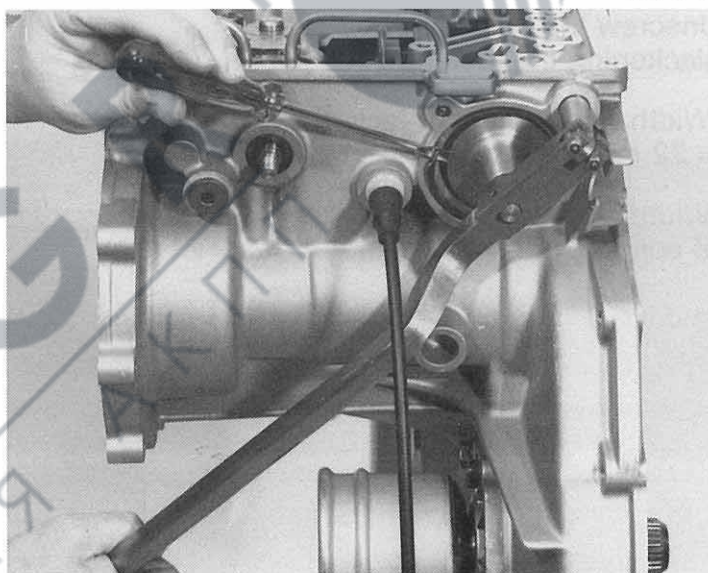

85 123

Take out cover and piston C' cpl.

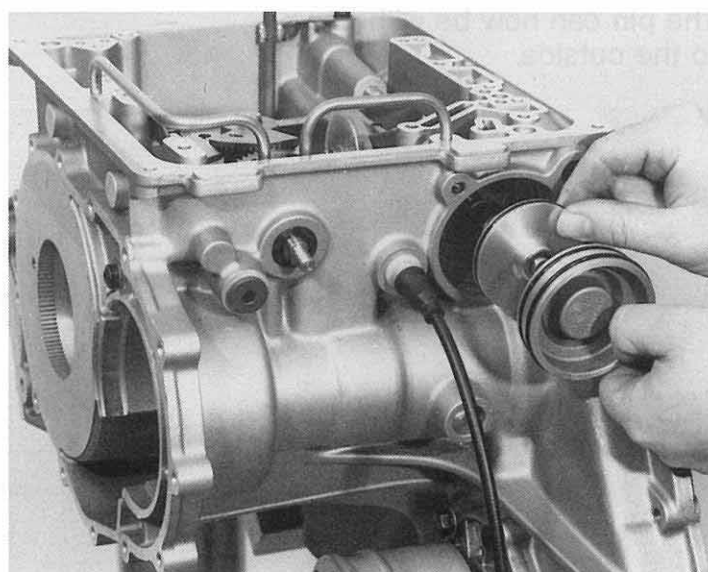

84 072

Piston C' can be disassembled for cleaning.

Slip spring off pin. The piston and the two plate springs can be removed after pulling the circlip off with a screwdriver.

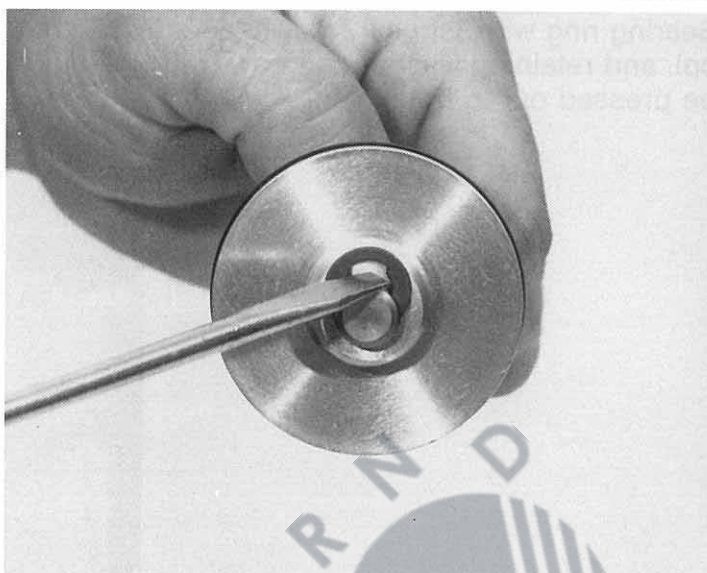

85 124

Unscrew the adjusting bolt after slackening the lock nut.

(Width across flats of lock nut = 22 mm)

(Width across flats of hexagon of adjusting bolt = 6 mm)

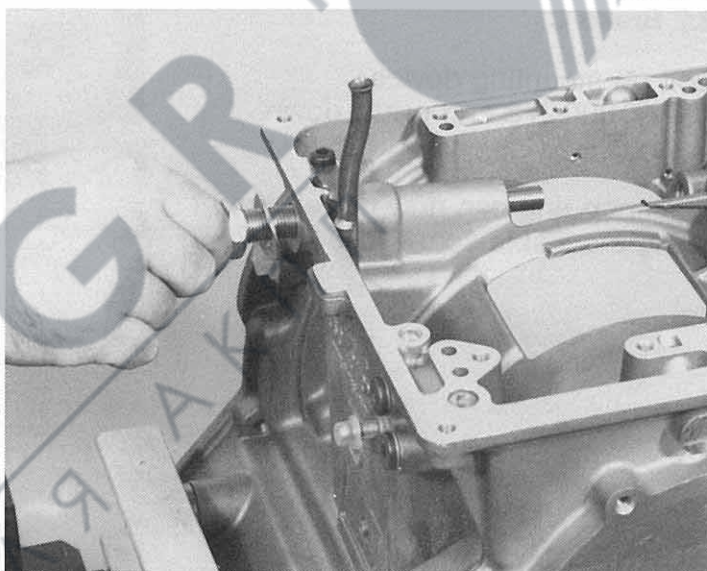

85 125

The pin can now be withdrawn to the outside.

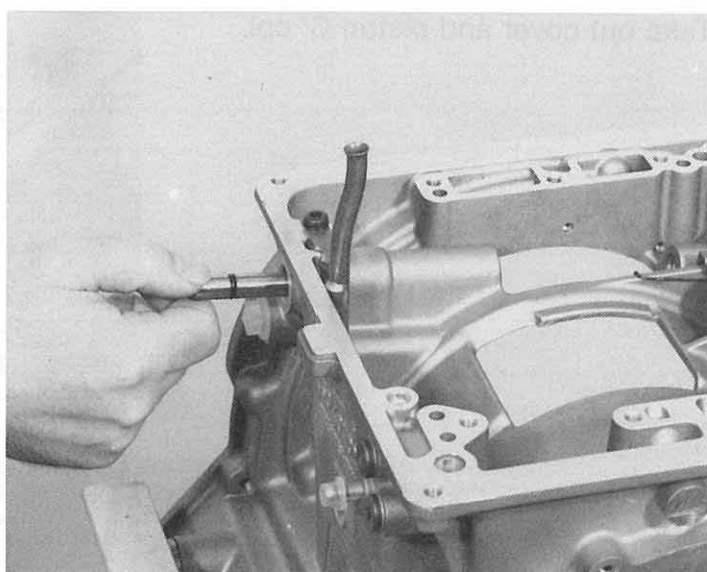

2.3 Brake D

Turn transmission through 90°. Use two suitable screwdrivers to release the snap ring.

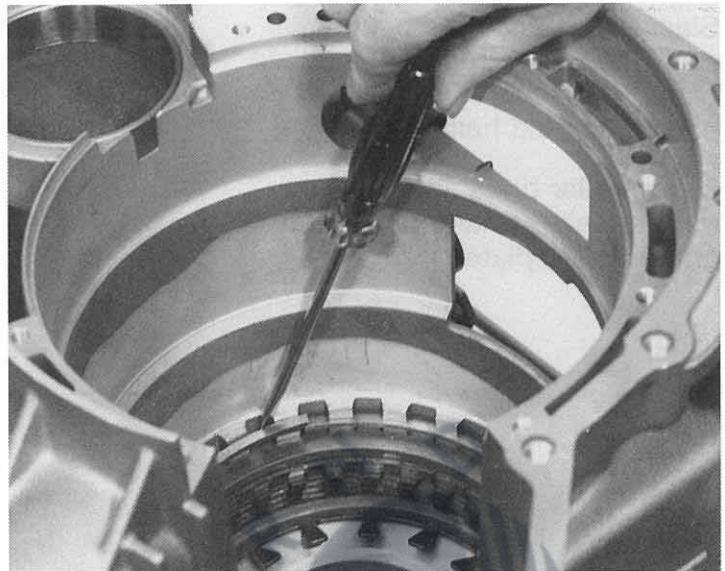

85 126

Take out the cpl. set of discs of brake D. Remove plate spring.



85 127

Use compressed air to press out piston D.

Position the air gun against the oil feed passage, as shown in Fig. 85 128.

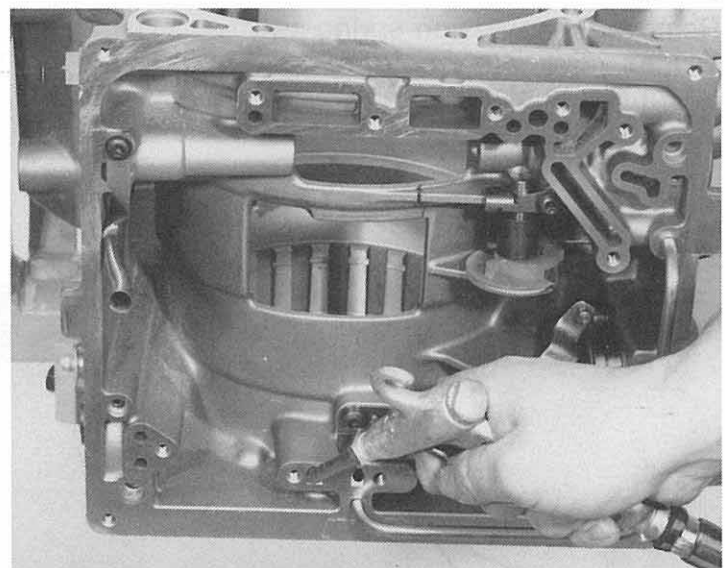

85 128

2.4 Intermediate plate with brake C and pump

85 129

Slacken fastening bolts and separate pump from intermediate plate. (Apply light blows with plastic headed hammer to side).

Rectangular rings and locating pin normally remain in the intermediate plate.

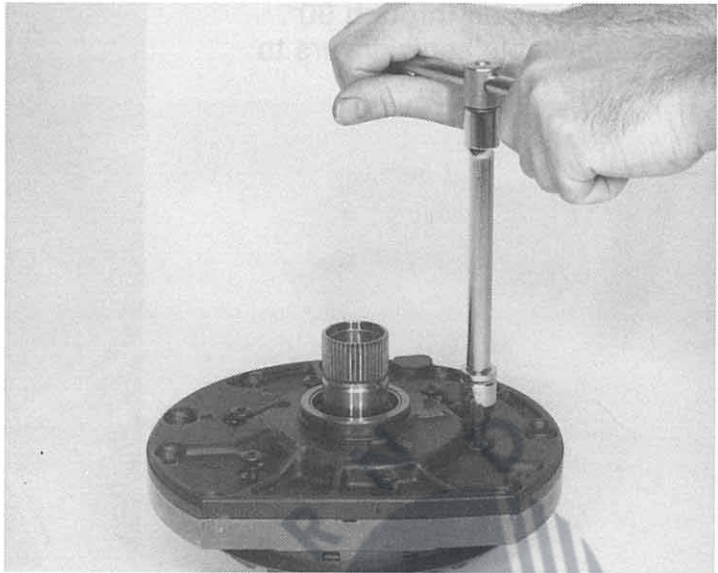

The pump can be disassembled by taking out the pump wheel and hollow gear.

85 130

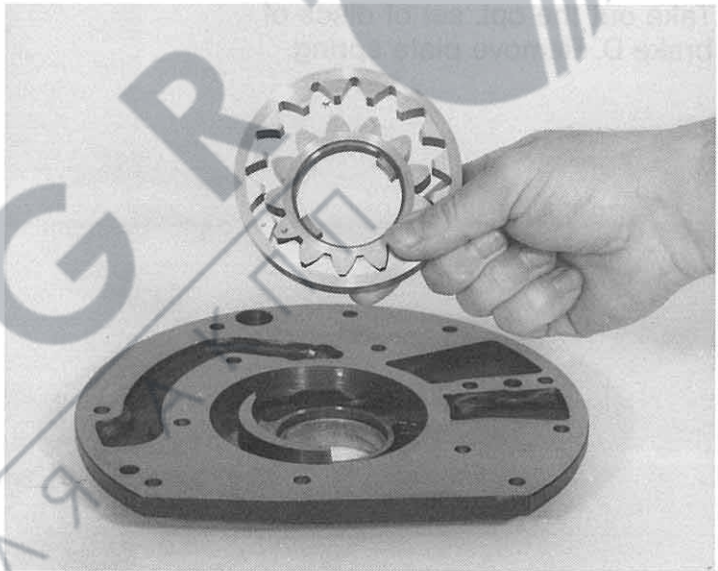

Remove compression spring as well as valve with cap from the intermediate plate.

85 131

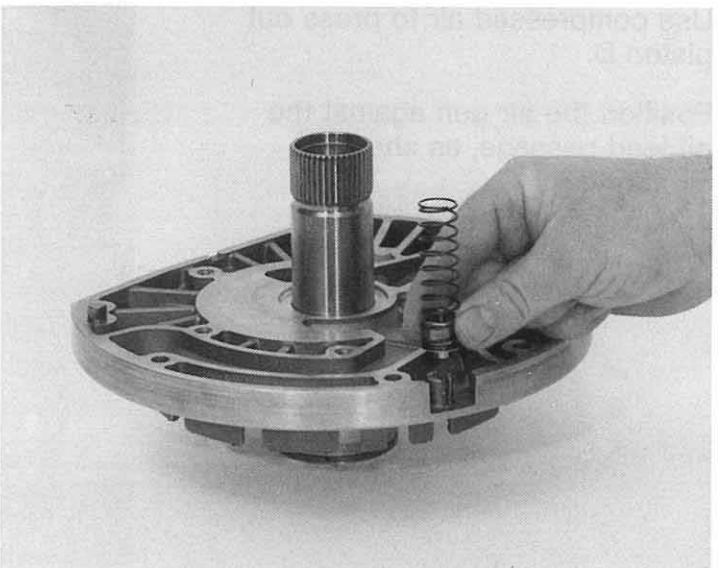

85 132

Release snap ring from the groove and take out cpl. set of discs of brake C together with plate spring.

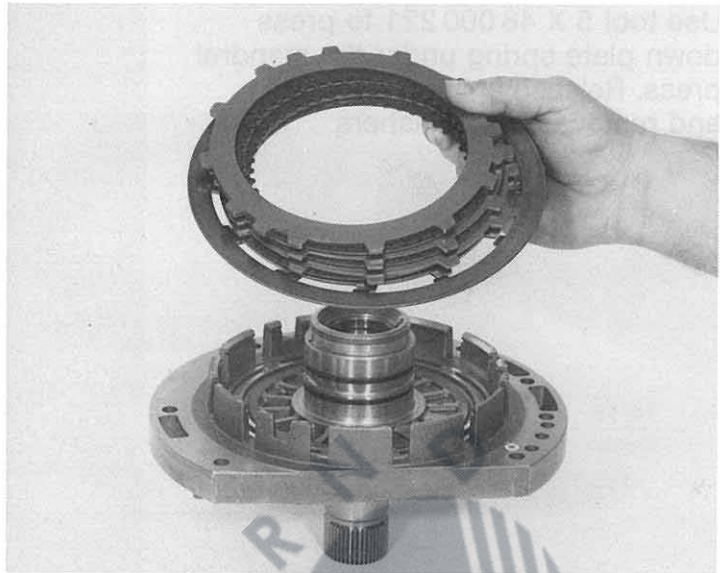

85 133

Press out piston C by screwing in two bolts at opposite points from the pump end.

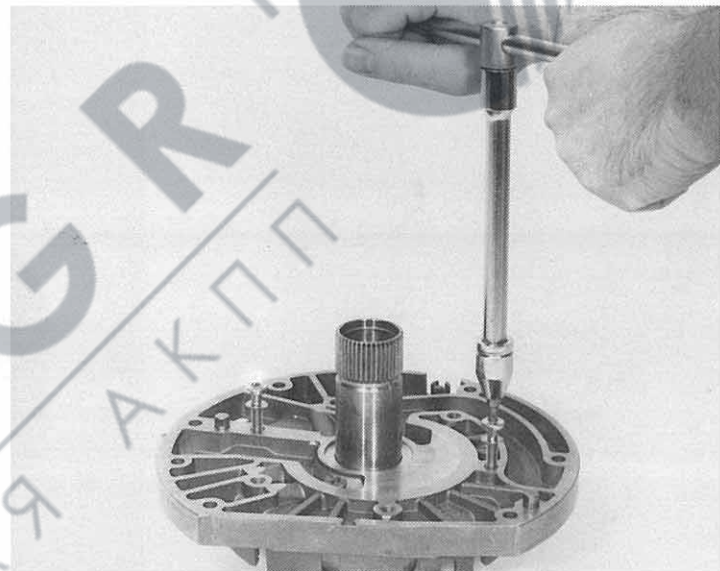

85 134

2.5 Clutch B with 2nd gear freewheel

Release snap ring and take out cpl. set of discs.

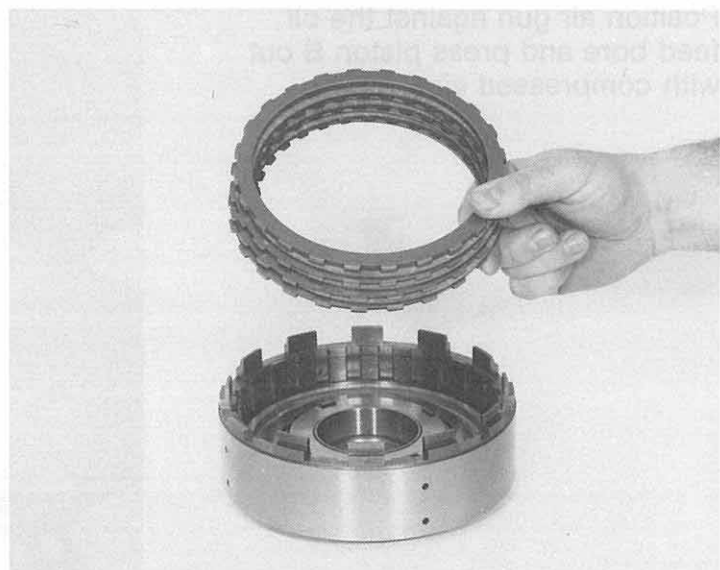

85 135

Use tool 5 X 46 000 221 to press down plate spring under the mandrel press. Release split retaining ring and remove thrust washers.

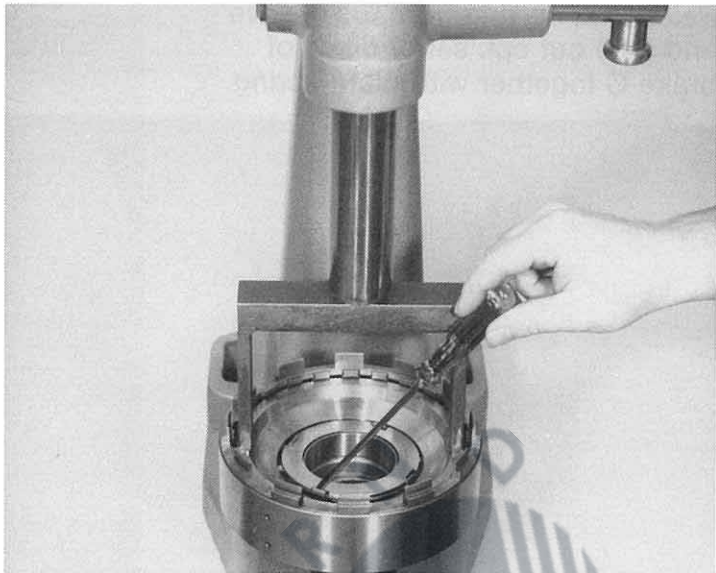

85 136

Take out plate spring.

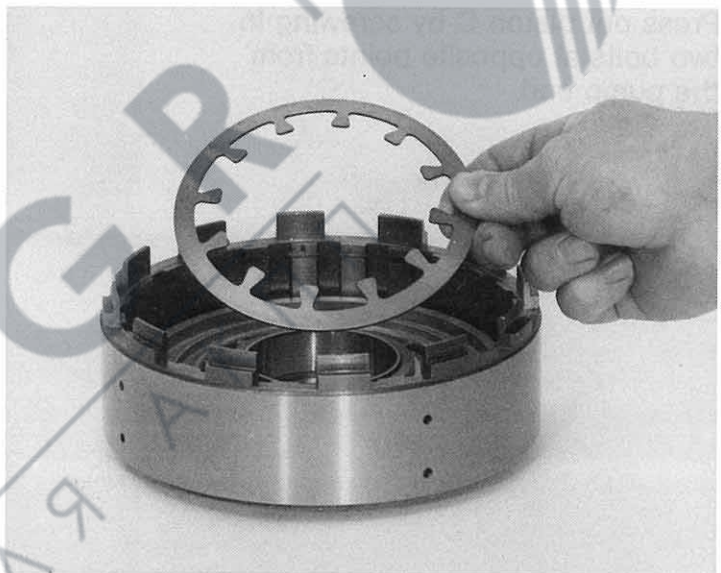

85 137

Position air gun against the oil feed bore and press piston B out with compressed air.

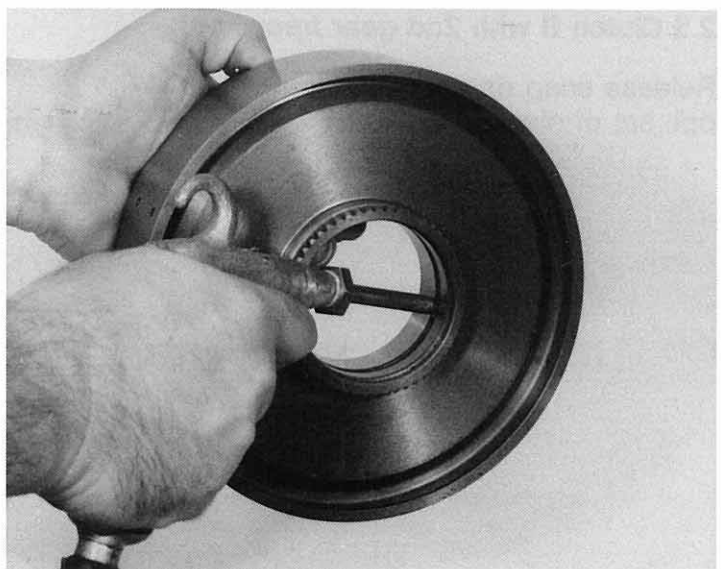

85 138

Take the intermediate ring out of the piston.

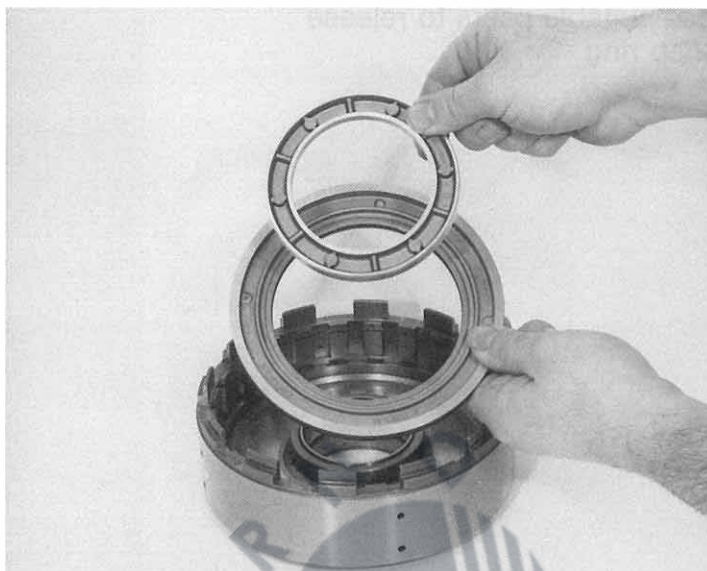

85 139

The 2nd gear freewheel can be disassembled for cleaning. First press the freewheel inner ring out of cage.

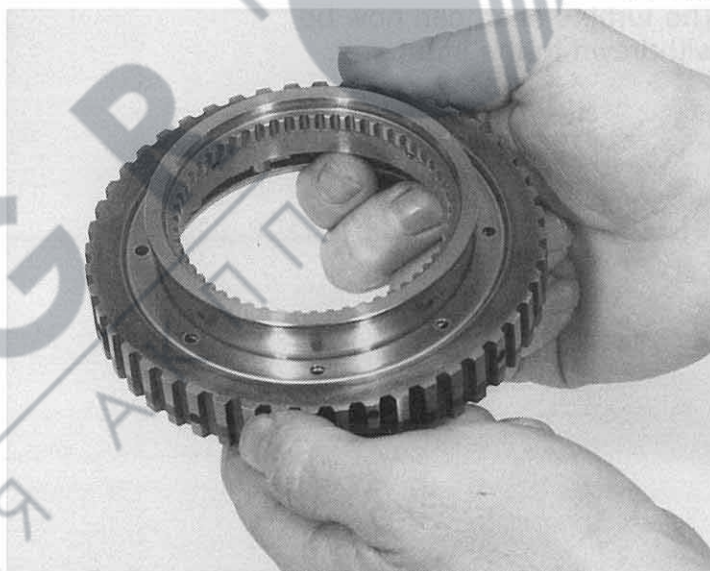

85 140

Separate the two cover washers together with the freewheel cage from the outer ring.

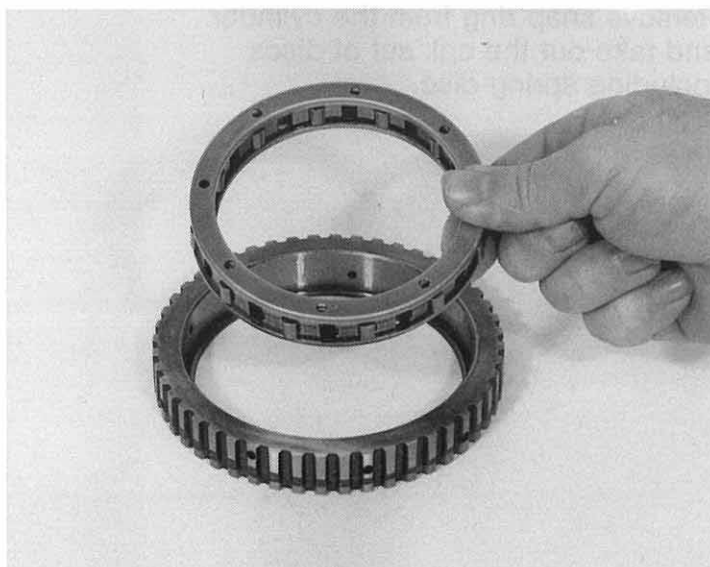

2.6 Clutch A

85 141

Use suitable pliers to release snap ring.

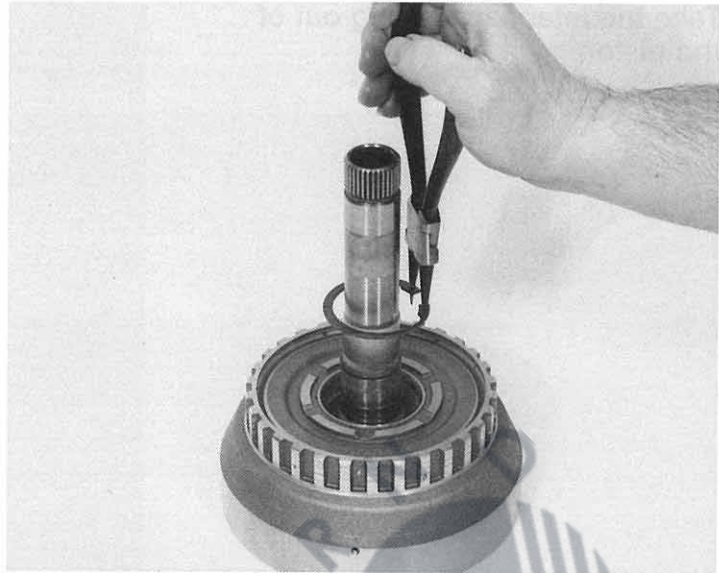

The turbine shaft can now be withdrawn to the input end.

85 142

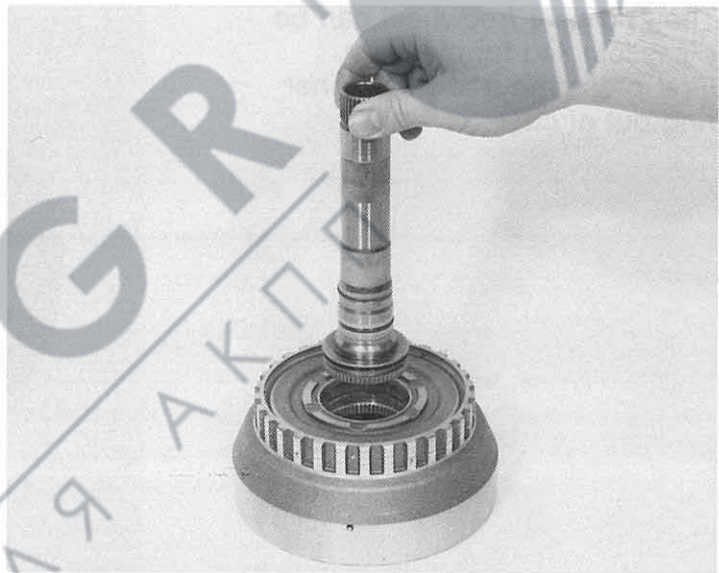

Remove snap ring from the cylinder and take out the cpl. set of discs including spring disc.

85 143

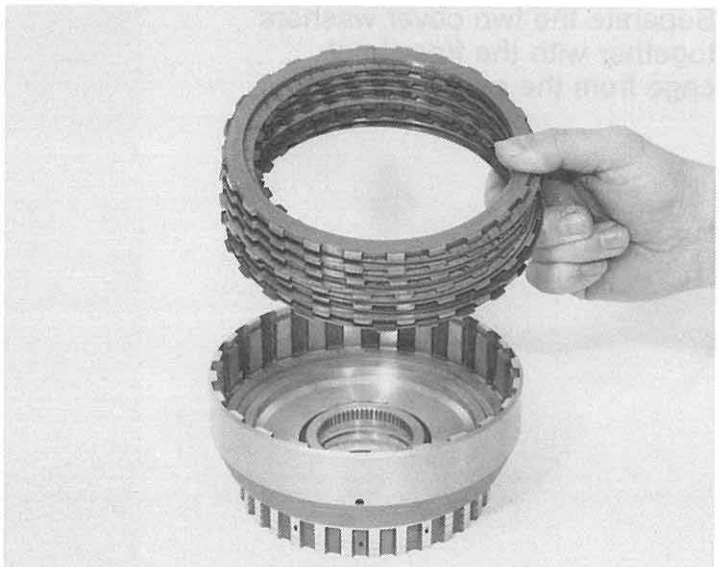

Use the legs of assembly aid 5 X 46 000 167 to press down the baffle plate under the mandrel press and release the snap ring with suitable pliers and a screwdriver.

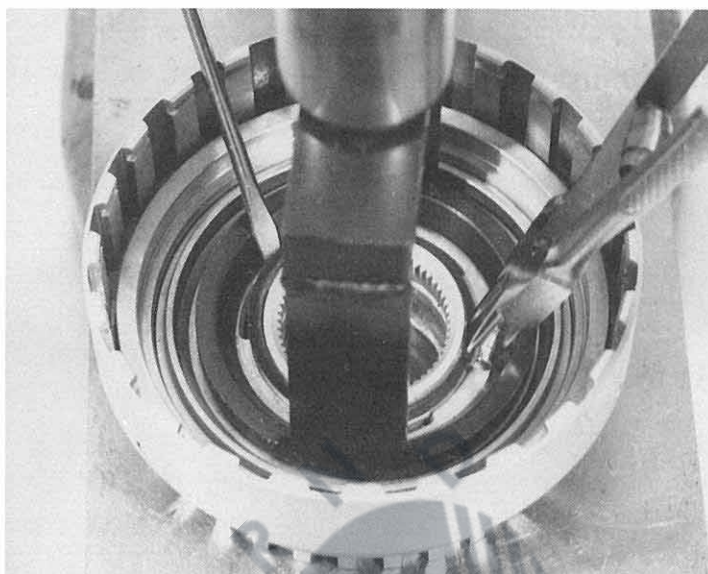

Take out the baffle plate and the two plate springs below by lightly knocking them against the workbench.

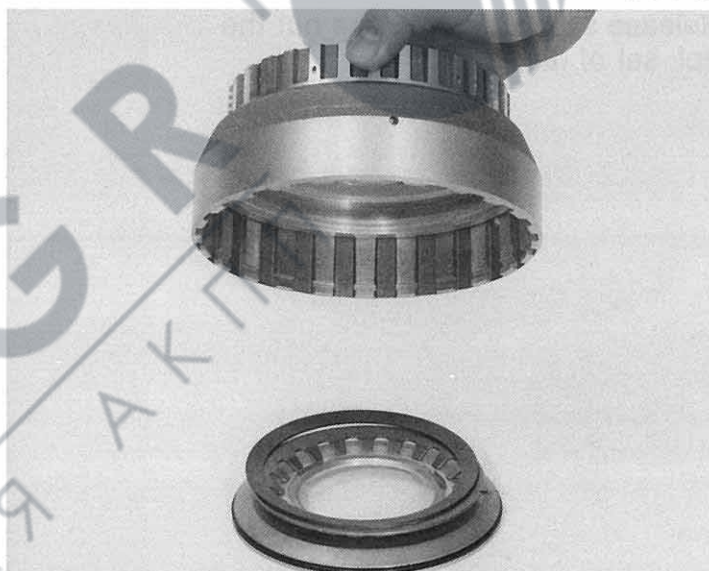

Position the compressed air gun against one of the two oil feed bores, cover over the two open oil feed bores with the tips of your fingers and force piston A out with the compressed air.

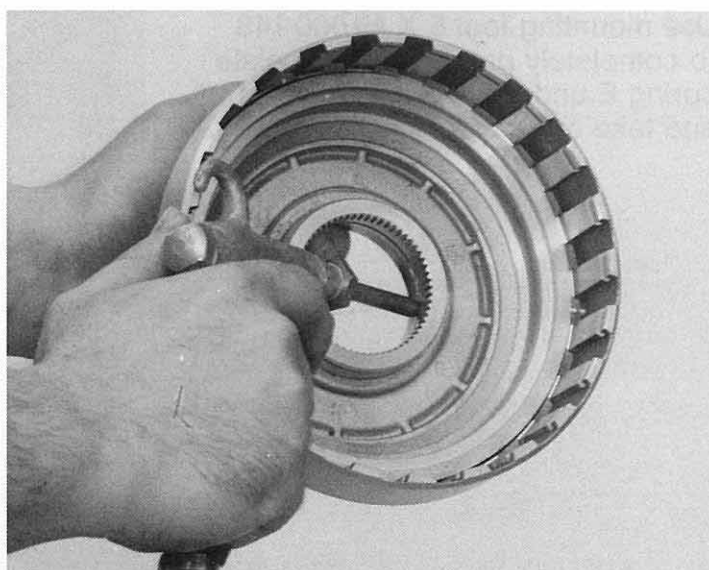

2.7 Clutch E

Take thrust washer off the engine shaft.

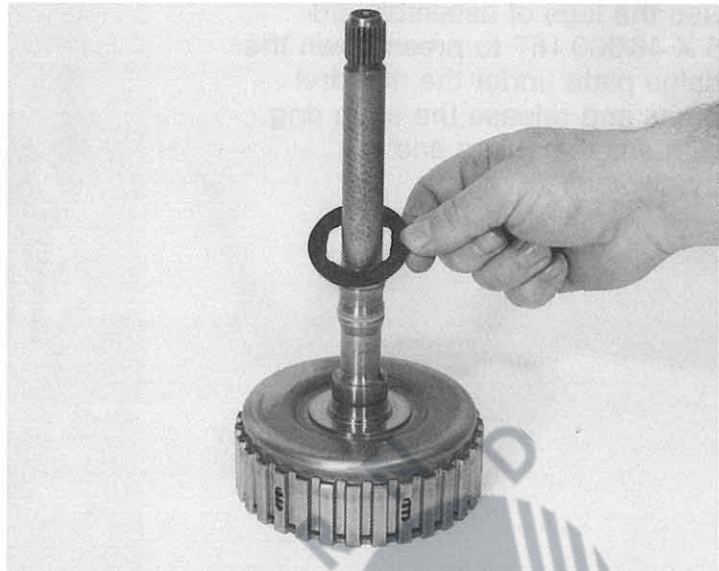

Release snap ring and take out the cpl. set of discs.

84 096

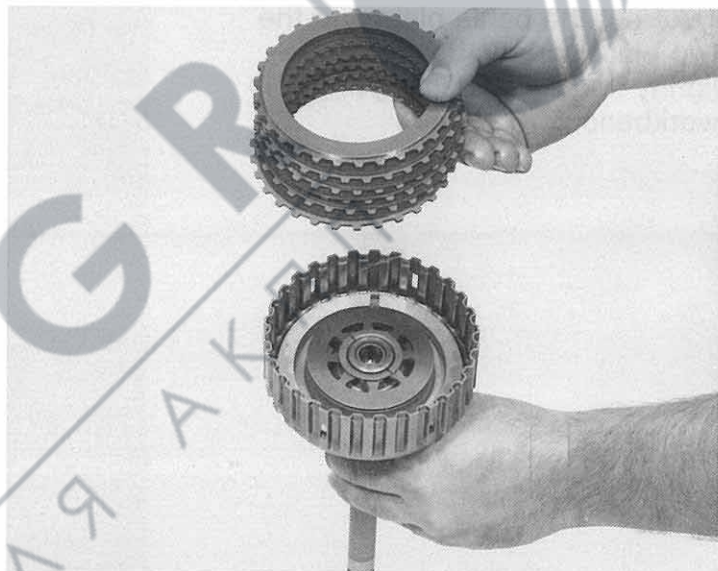

Use mounting tool 5 X 46 000 148 to completely press down the plate spring E under the mandrel press and take out the split retaining ring.

84 097

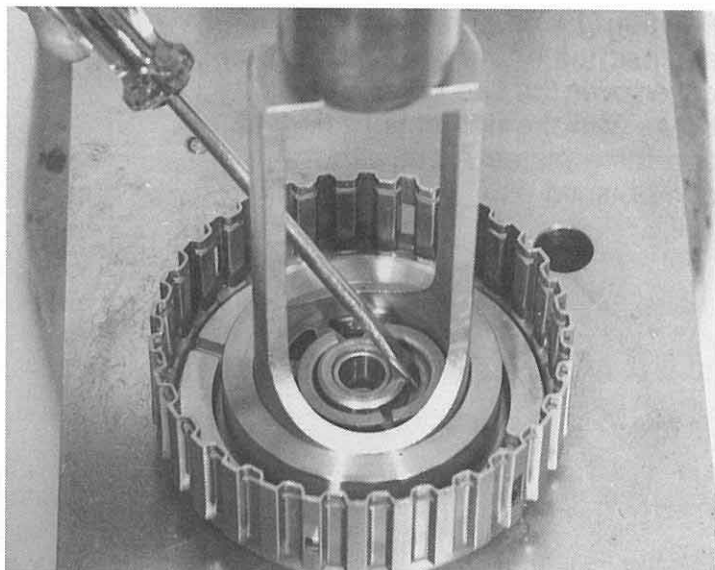

Remove plate spring.
Use compressed air to force out piston E. This is done by positioning a compressed air gun against the oil feed bore.

The rectangular rings normally remain on the engine shaft.

Note! The white plastic rings have chamfered ends.

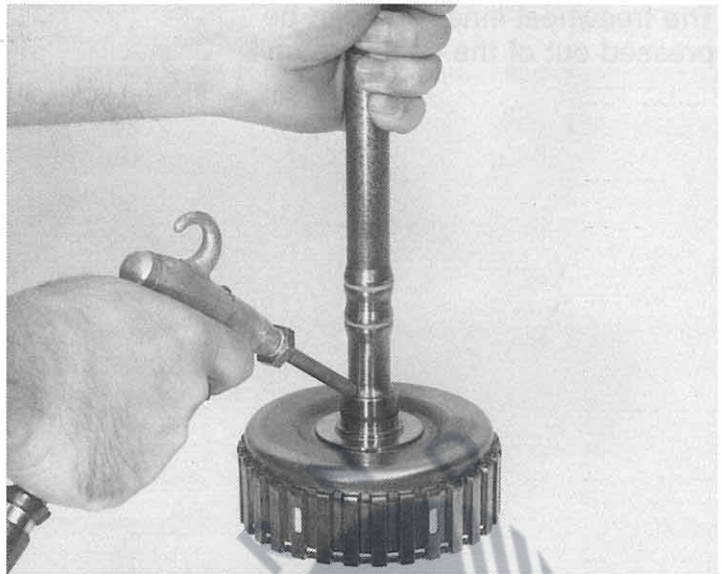

84 099

2.8 Output shaft and 1st gear freewheel

After releasing the snap ring, the hollow gear can be separated from the output shaft.

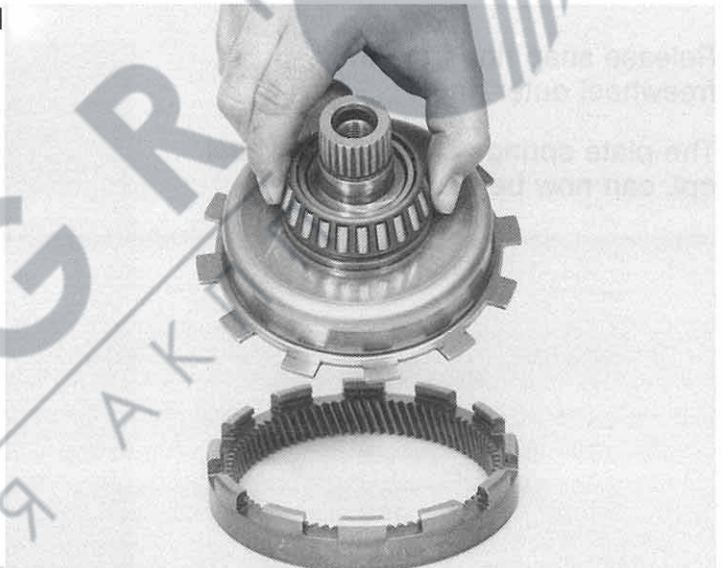

84 100

Use the Rollex extractor 48.500, screwed into the Rollex basic tool 1000.1, to pull off the tapered roller bearing inner ring.



The freewheel inner ring can be pressed out of the complete unit.

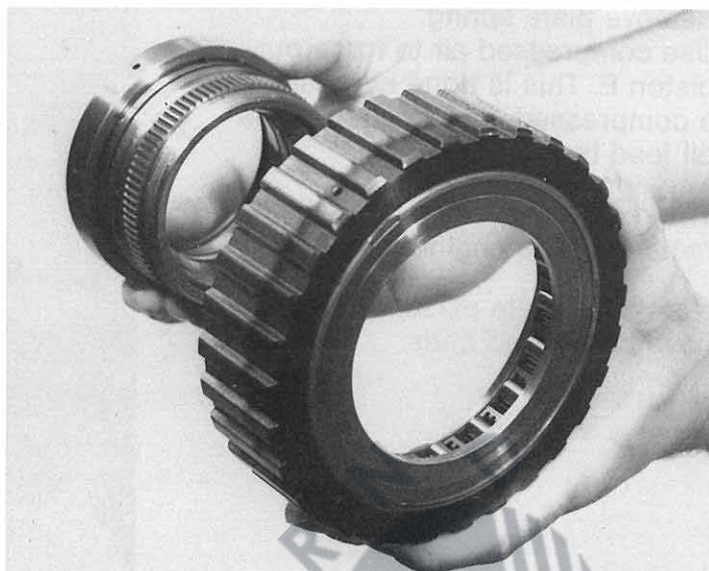

Release snap ring from the freewheel outer ring.

The plate springs and the freewheel cpl. can now be disassembled.

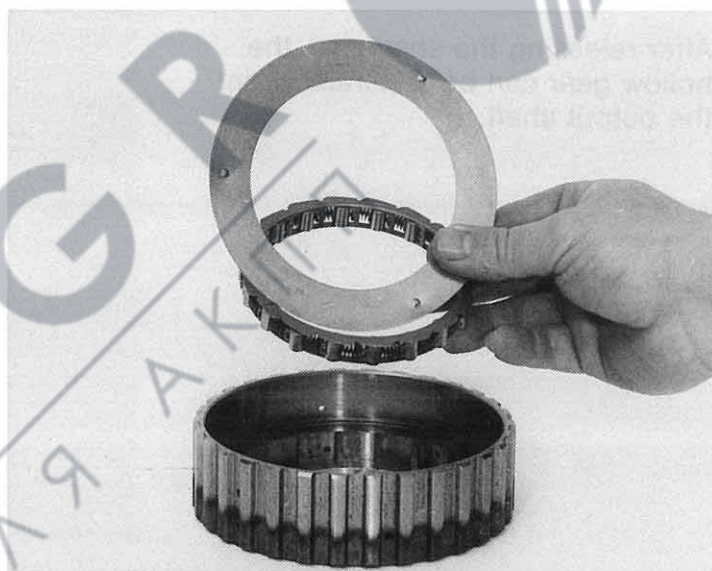

2.9 Governor and differential

85 151

Slacken 4 cylindrical bolts and separate 1st and 2nd stage of governor housing from the hub.

(Width across flats
= Torx socket – TX 27)

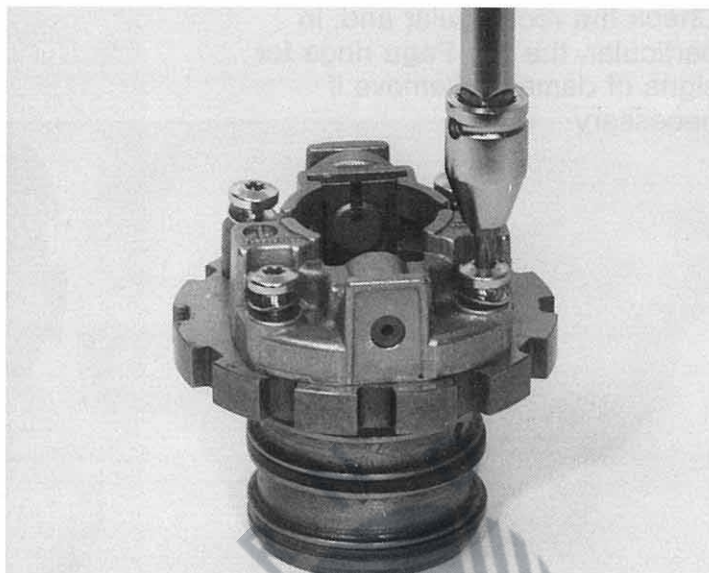

Disassembling 1st stage:
Pull stop plate and press out the governor piston of 1st stage.

85 152

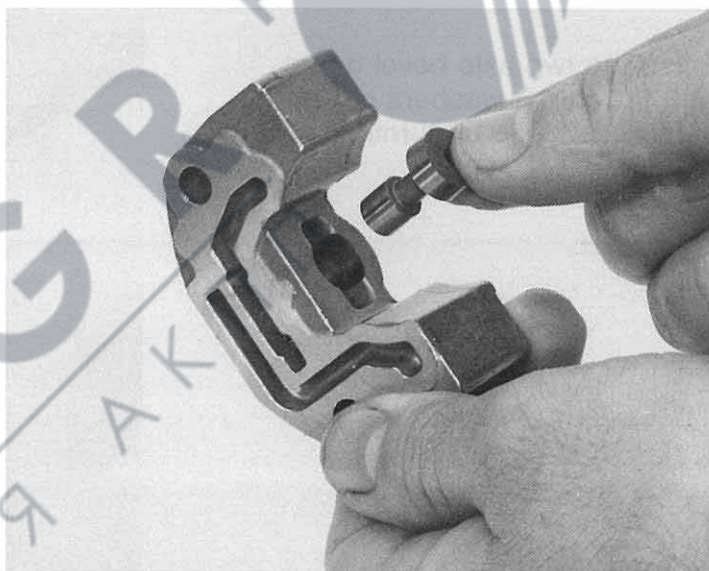

Disassembling 2nd stage:
Use a screwdriver to press down compression spring. Remove retaining plate, compression spring and governor piston of 2nd stage.

85 153

Caution!

If the governor is damaged, replace the housing cpl. Stop plate and retaining plate may be replaced separately.



85 154

Check the rectangular and, in particular, the two Pagu rings for signs of damage. Remove if necessary.

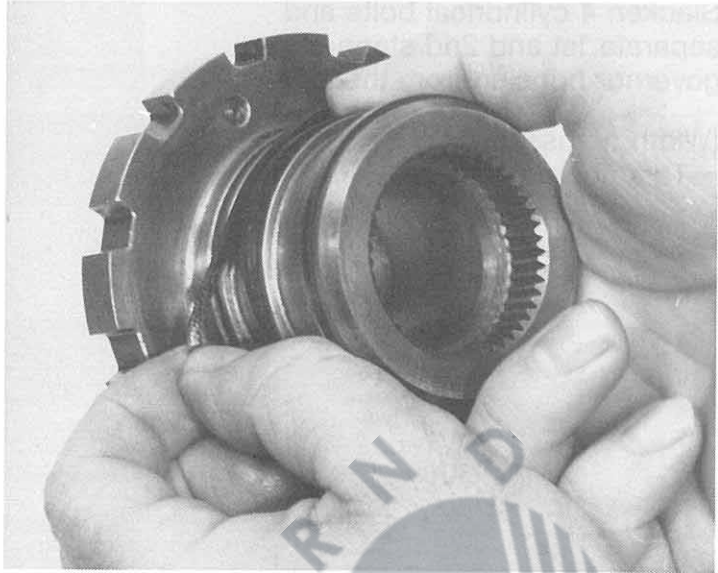

85 155

Press the two axle bevel gears with the thrust washers out of the differential cage by turning them.

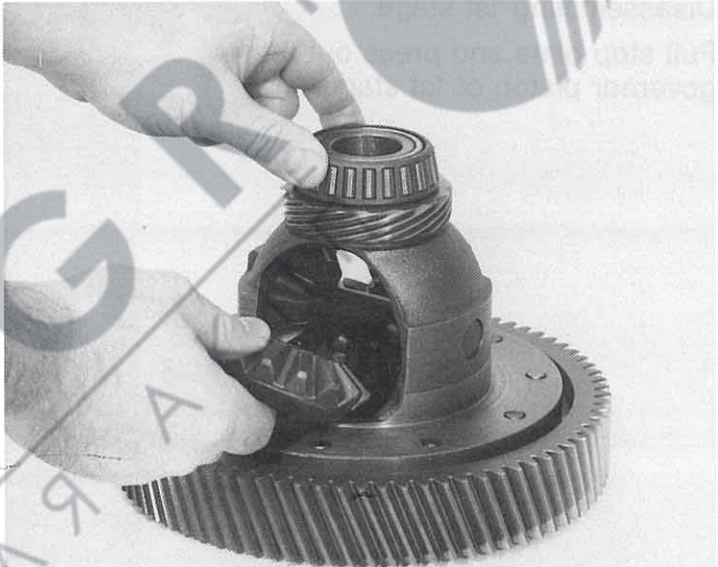

85 156

Push the differential bevel gears together toward the middle and check the pin for signs of scoring.
Replace the cpl. differential if there are signs of damage.

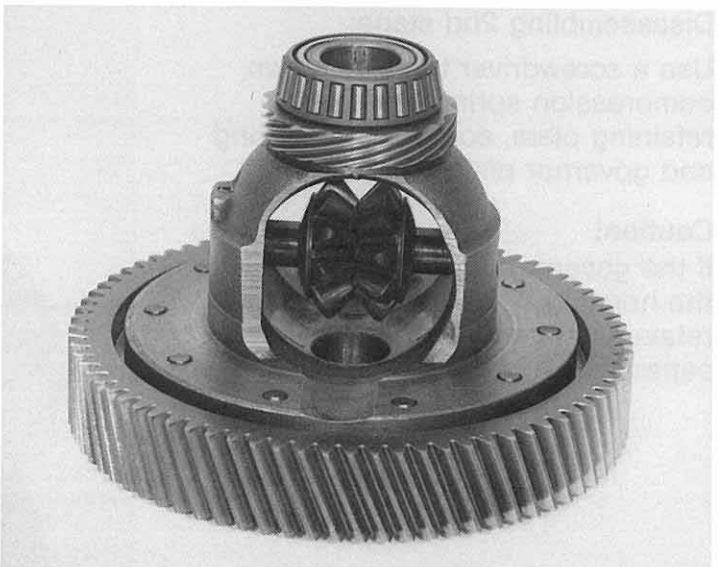

Insert differential into the special tool 5 X 46 000 305, clamp in vice and slacken the 10 fastening bolts. This is the only method of separating the spur gear from the differential.

(Width across flats = 15 mm)

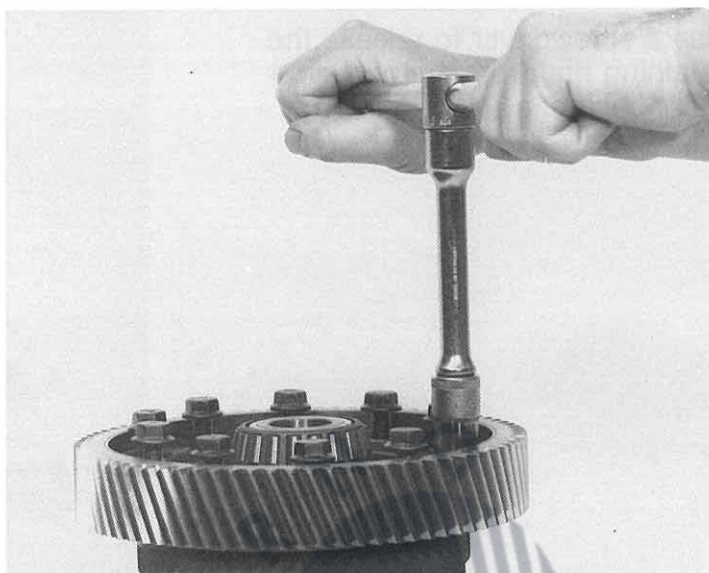

Pull the tapered roller bearing inner ring off the differential cage with the Rollex gripping device 503 349/S screwed into Rollex basic tool 1000 1, and using the plug 5 X 46 000 297.

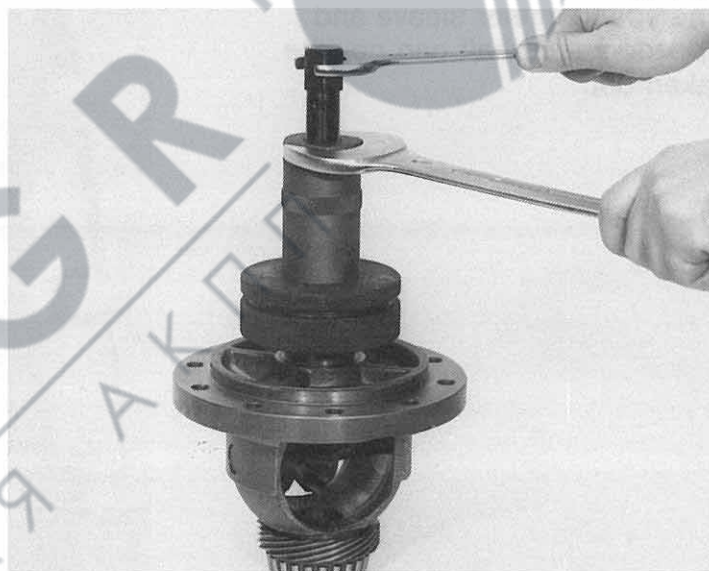

Pull off the other tapered roller bearing inner ring using the Rollex gripping device 300 849. The speedometer worm can now be lifted off.



2.10 Input shafts and converter bell housing with speedometer

85 160

Use a screwdriver to release the retaining ring from the converter bell housing.

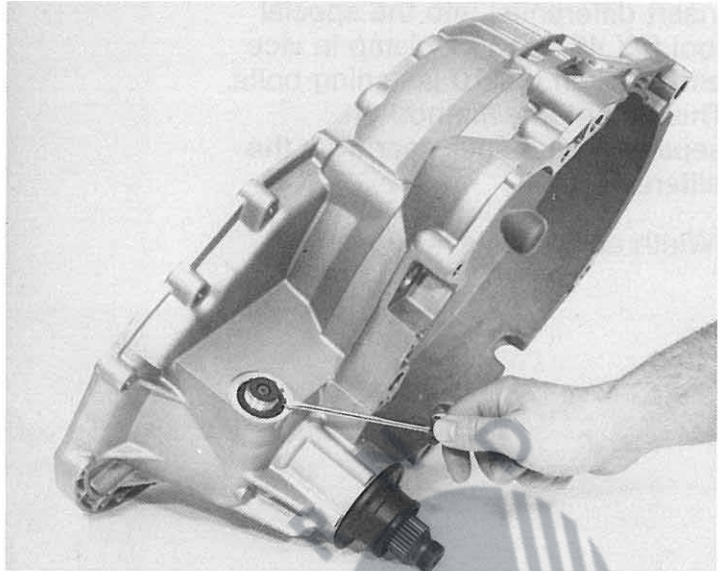

The speedometer sleeve and speedometer shaft can now be taken out.

85 161

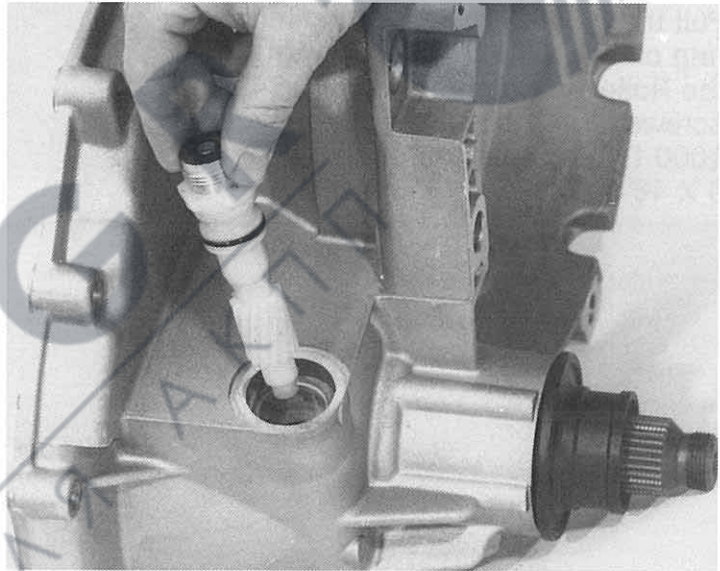

Withdraw speedometer shaft from sleeve. Take off O ring and seal from speedometer sleeve.

85 162

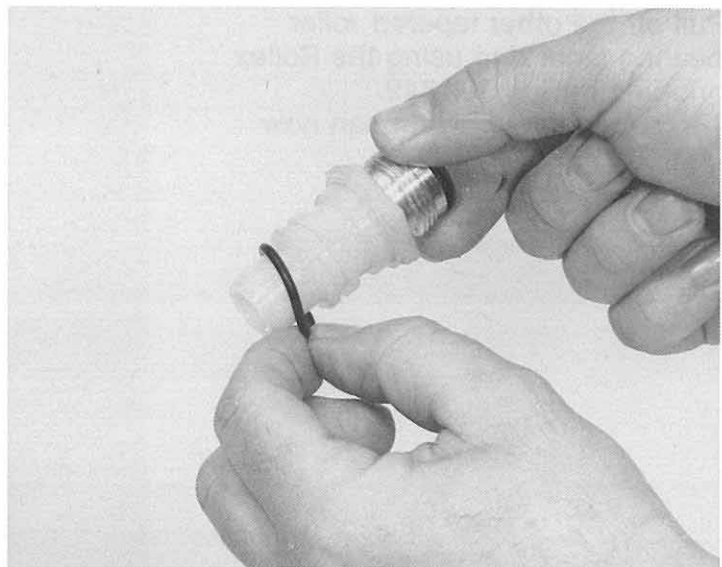

85 163

Slip off O ring and seal from right of input shaft and use pliers to remove the locking ring.

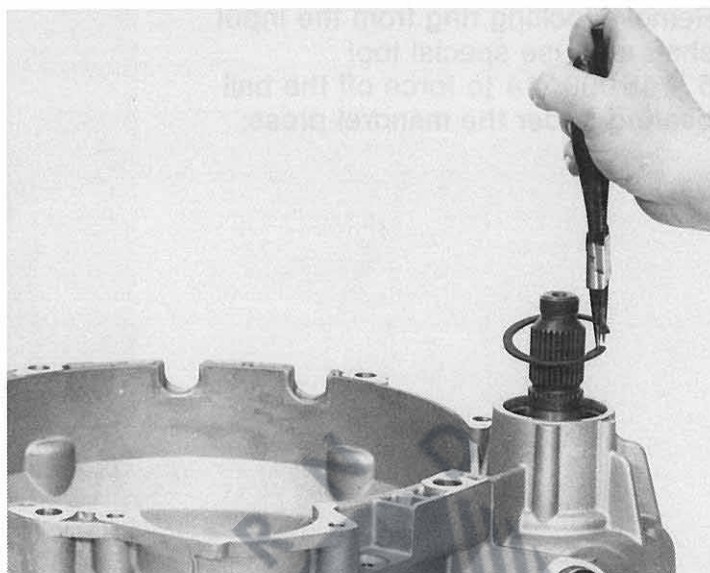

85 164

Knock the input shaft and shaft seal out of the converter bell housing with a plastic-headed hammer.

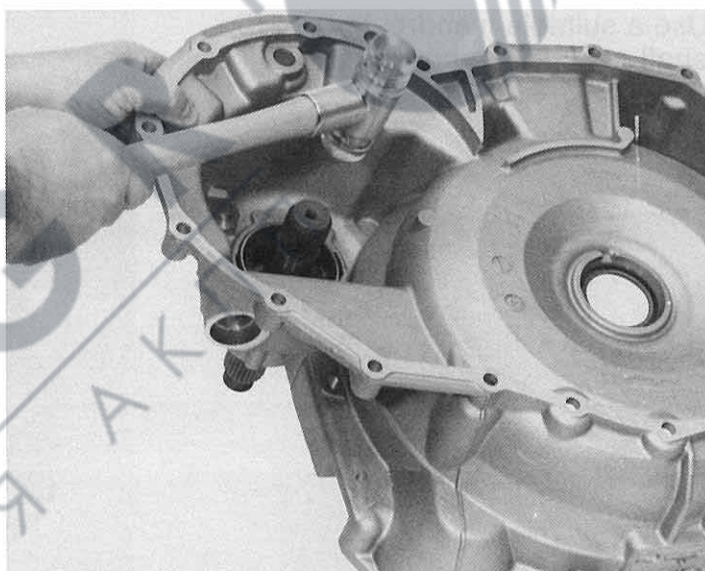

85 165

Slip shaft seal off input shaft.



85 166

Remove locking ring from the input shaft and use special tool 5 X 46 000 314 to force off the ball bearing under the mandrel press.

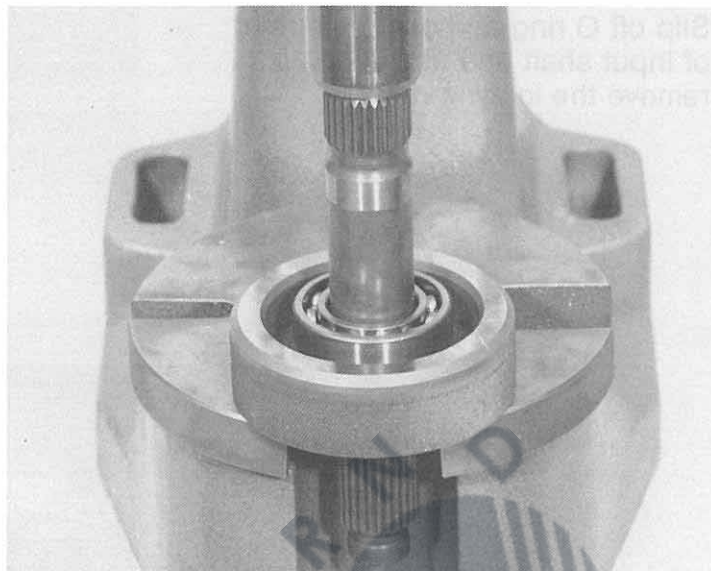

85 167

Use a suitable mandrel to take the shaft seal off the converter bell housing.

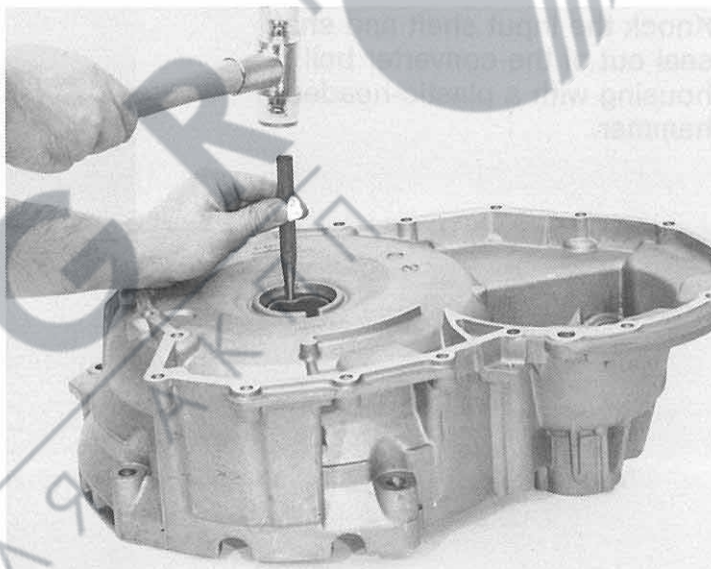

85 168

Pull off bearing ring with Kukko extractor 21/7, screwed into basic tool 22/2.

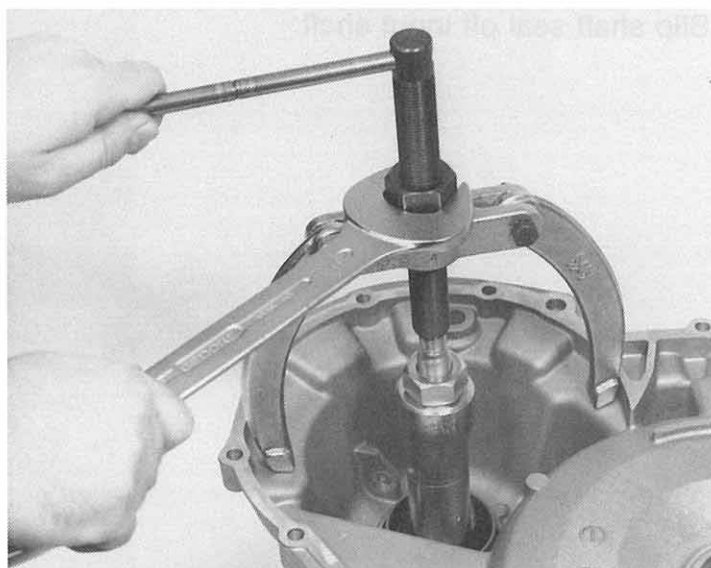

Remove input shaft to the left by at first unscrewing the 5 fastening bolts of the bearing cover.

(Width across flats = 13 mm)

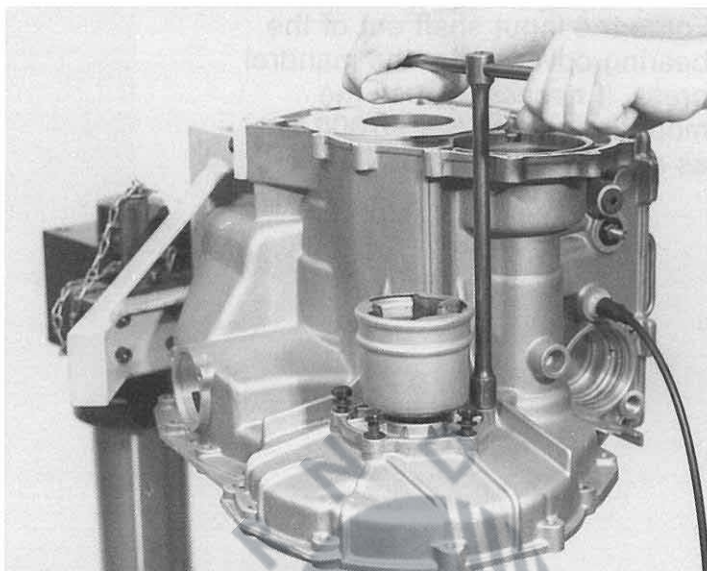

Turn transmission through 180° and knock the input shaft out of the transmission housing with light blows from a plastic-headed hammer.

Take off adjusting washer(s).

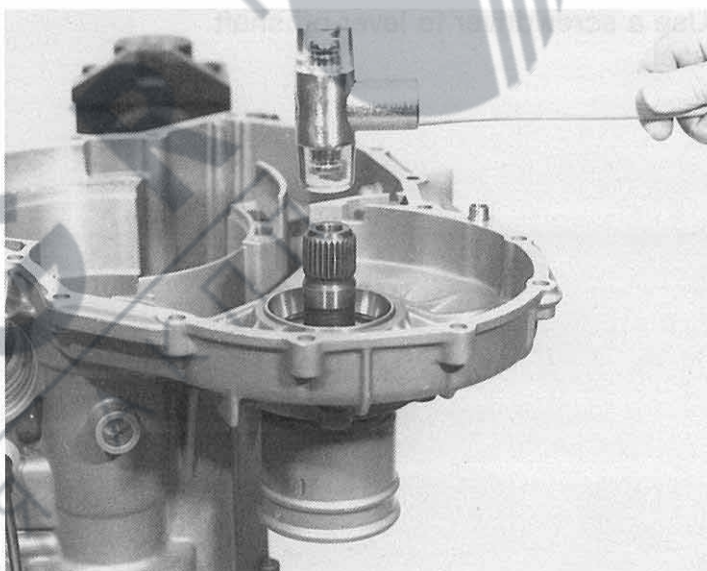

Pull off locking ring with special pliers.

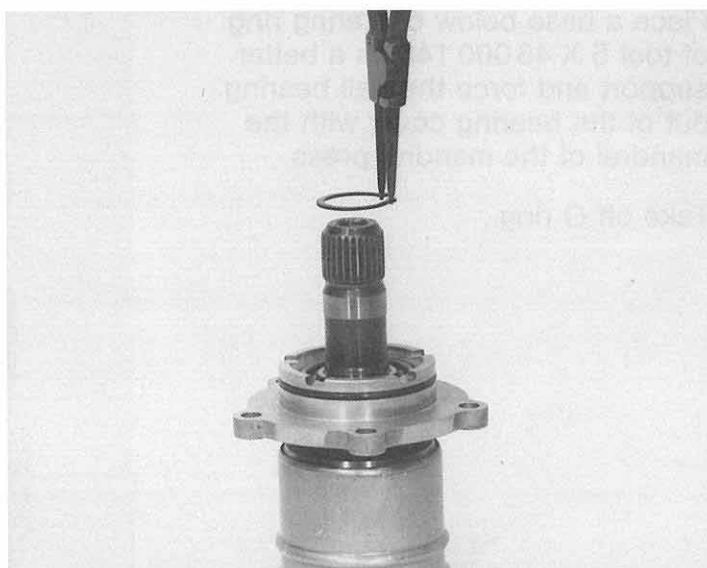

85 172

Force the input shaft out of the bearing cover under the mandrel press. If necessary, use the mounting device 5 X 46 000 221 as a base.

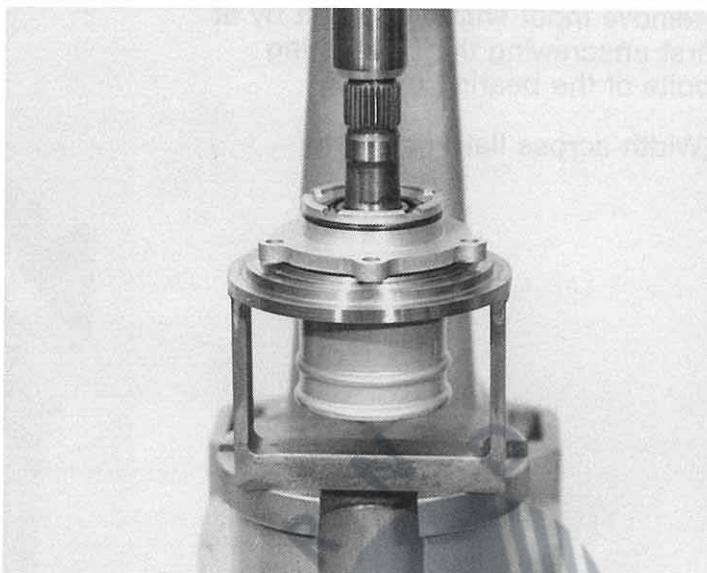

85 173

Use a screwdriver to lever off shaft seal.

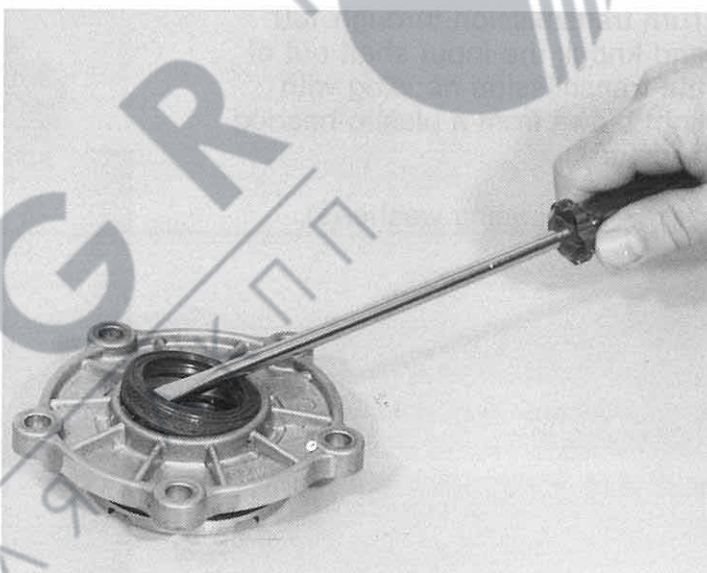

85 174

Place a base below centering ring of tool 5 X 46 000 148 as a better support and force the ball bearing out of the bearing cover with the mandrel of the mandrel press.

Take off O ring.



2.11 Housing with selector mechanism and parking interlock

85 175

Detach accelerator cable from cam and press out of housing using two suitable screwdrivers.

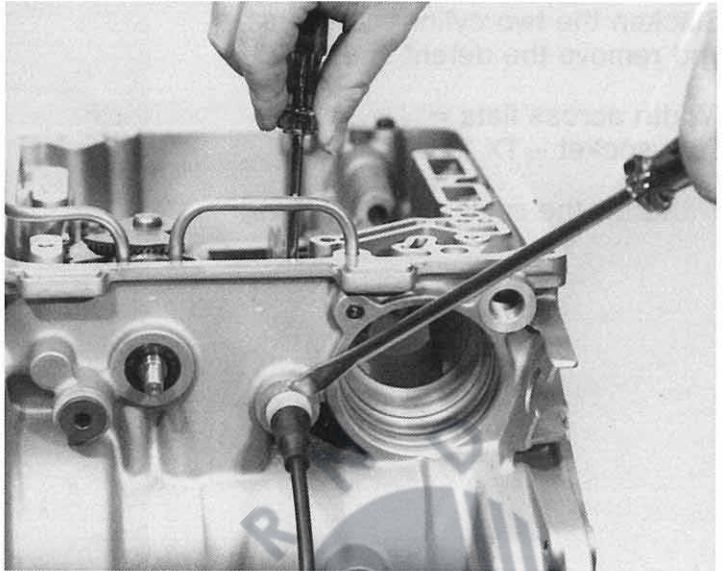

Slacken cylindrical bolt and take off retaining plate.

85 176

(Width across flats
= Torx socket – TX 27)

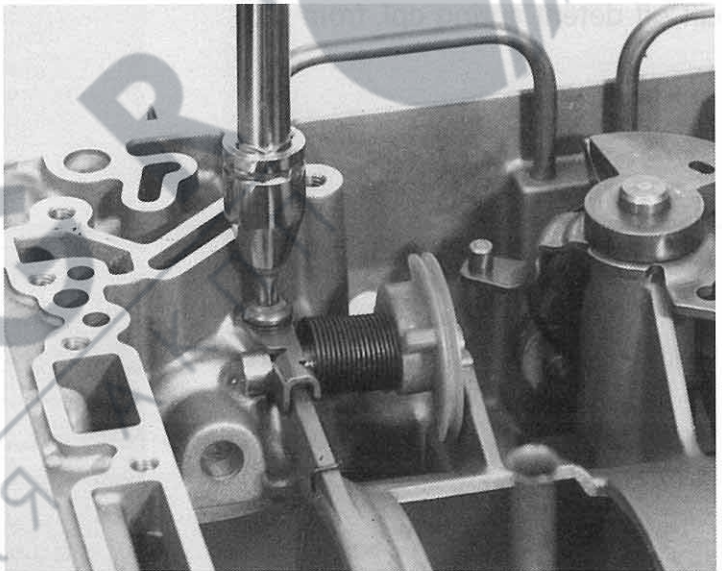

The accelerator cam axle can now be removed together with the leg spring and the accelerator cam.

85 177

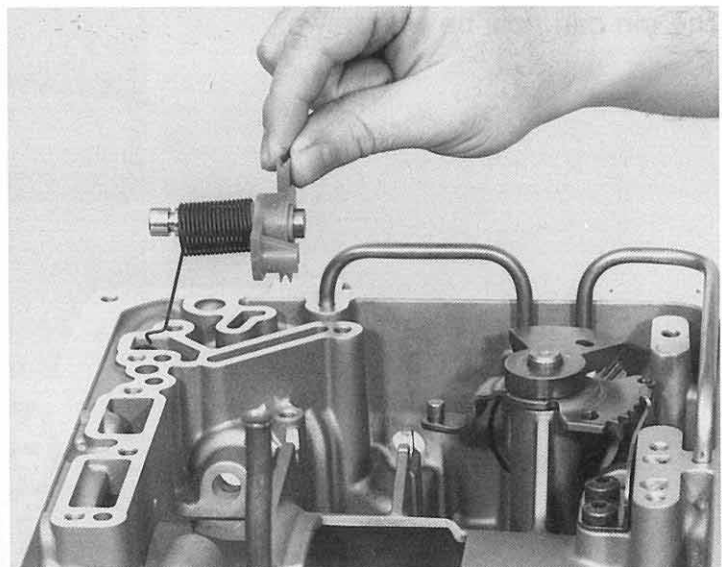

85 178

Slacken the two cylindrical bolts
and remove the detent spring.

(Width across flats =
Torx socket – TX 27)

Withdraw the small pin for locking.

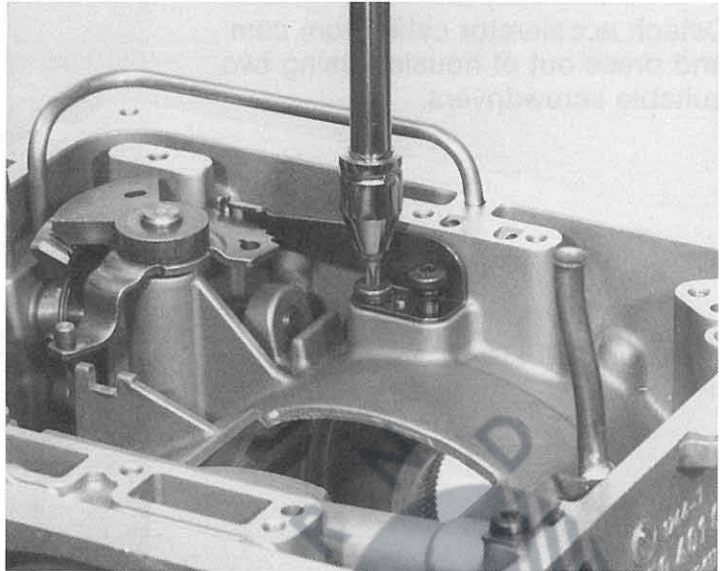

85 179

Lift off detent spring cpl. from pin.



85 180

The pin can now be withdrawn.

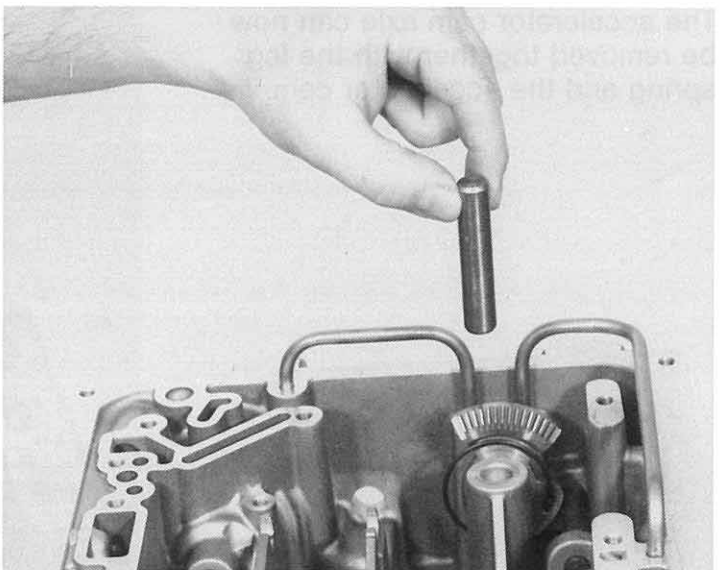

85 181

Remove screw plug and withdraw supporting shaft.

(Width across flats of hexagon socket = 6 mm)

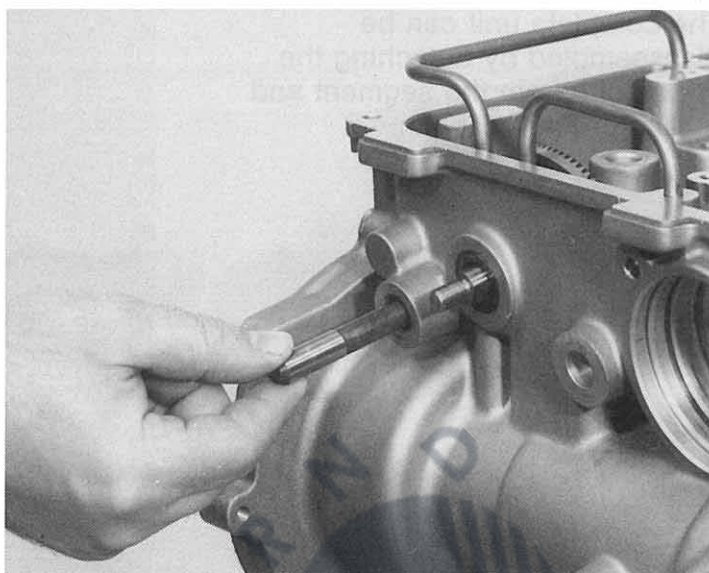

85 182

Use a suitable mandrel to knock out the tension pin far enough for the selector shaft to be drawn out.

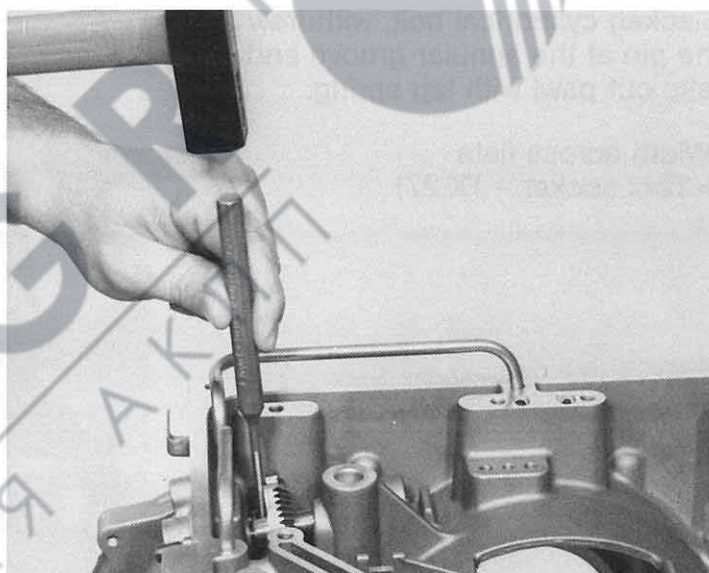

85 183

Remove segment with locking cam and adjusting washers by pressing the pawl down slightly.

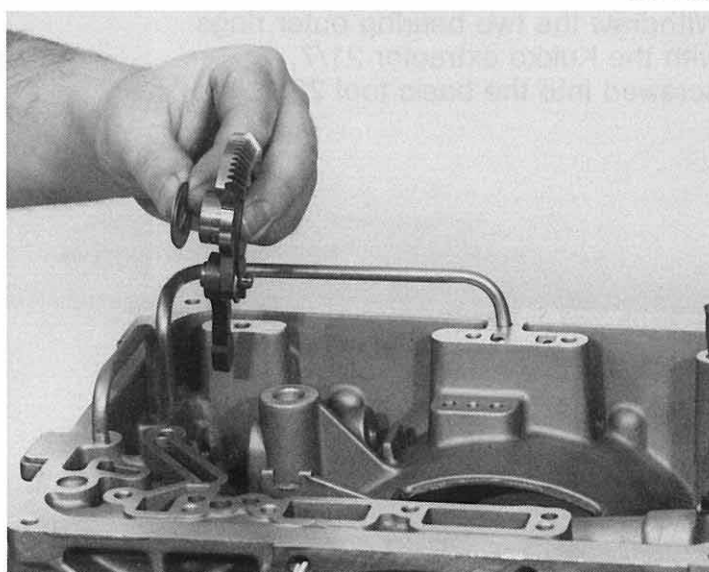

85 184

The complete unit can be disassembled by detaching the spring clip from the segment and pulling it out of the pin.

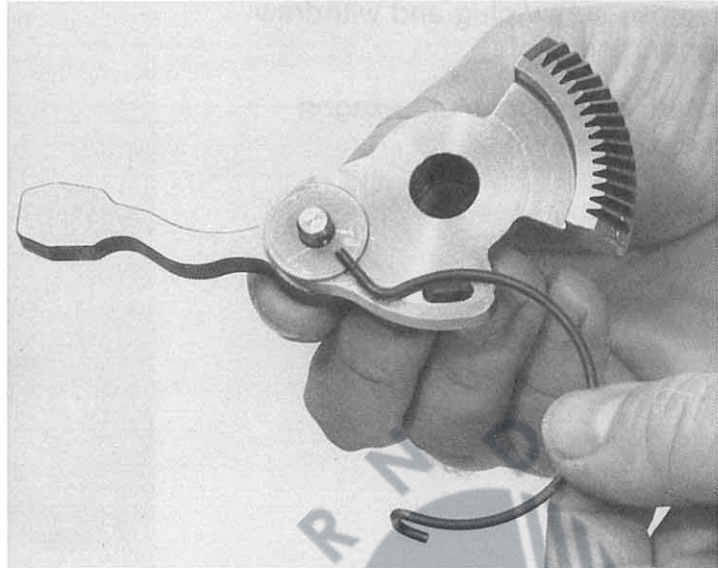

85 185

Slacken cylindrical bolt, withdraw the pin at the annular groove and take out pawl with leg spring.

(Width across flats
= Torx socket - TX 27)

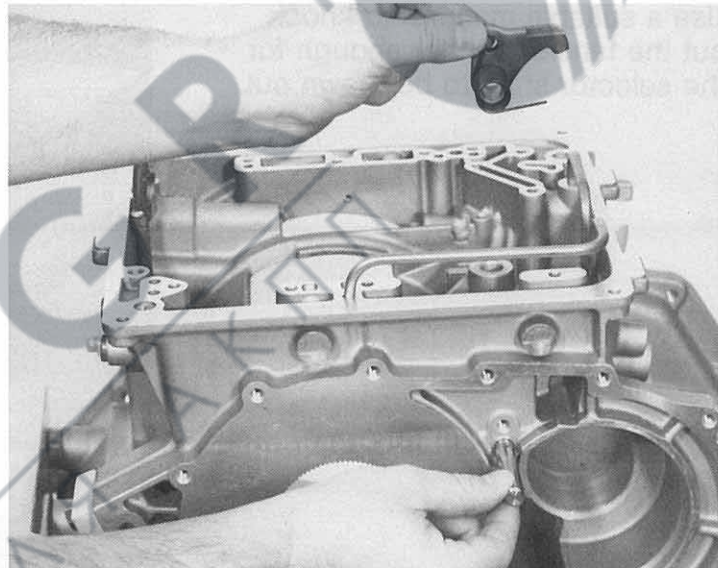

85 186

Withdraw the two bearing outer rings with the Kukko extractor 21/7, screwed into the basic tool 22/2.

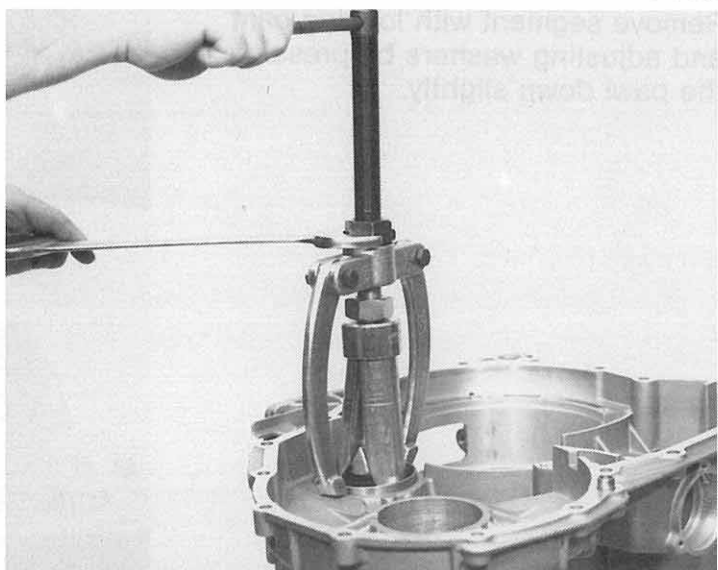

85 187

Remove shaft seal, selector shaft.

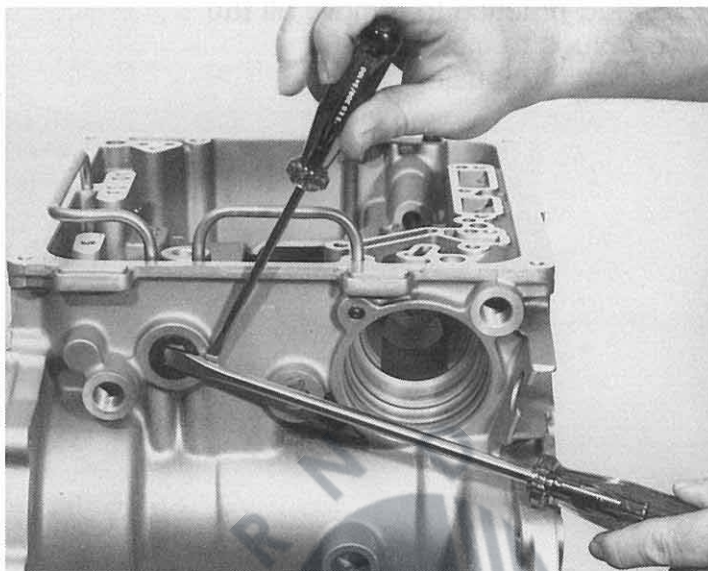

85 188

Remove tube (oil dipstick) by unscrewing the bolt.

(Width across flats
= Torx socket - TX 27)

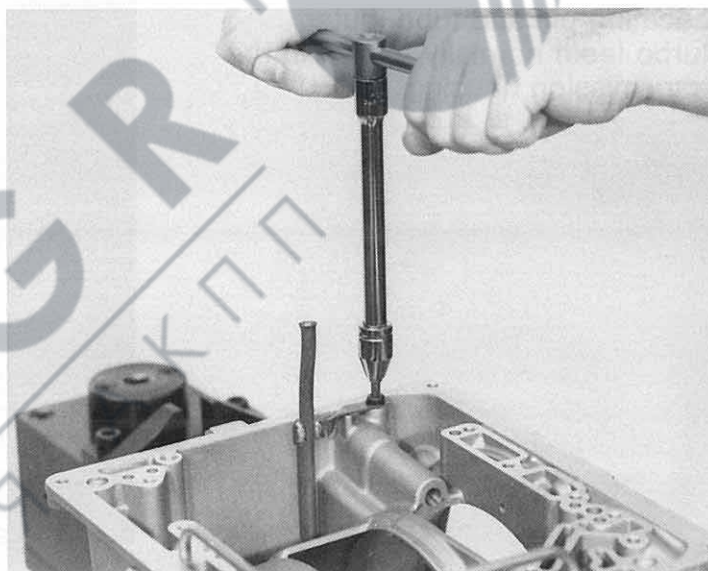

85 189

Withdraw oil tubes with suitable pliers.

Caution!

Do not damage sealing surface of housing.

Do not re-use oil tubes.

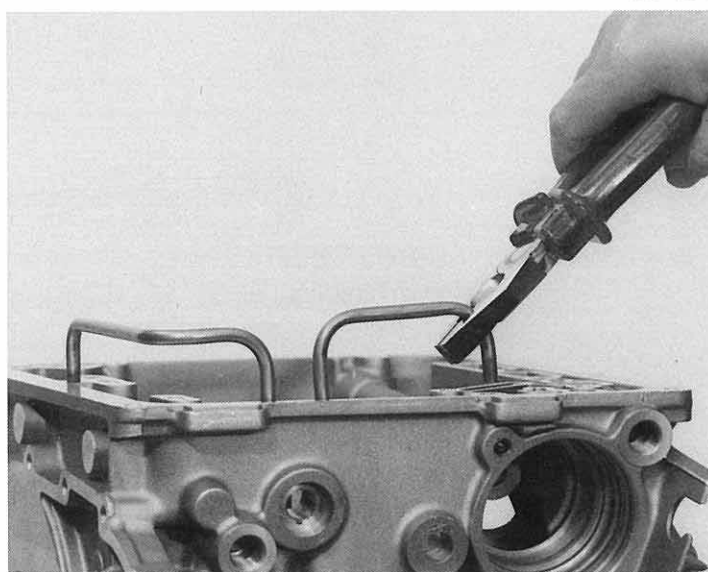

It is good practice to remove all the screw plugs to clean the transmission housing.

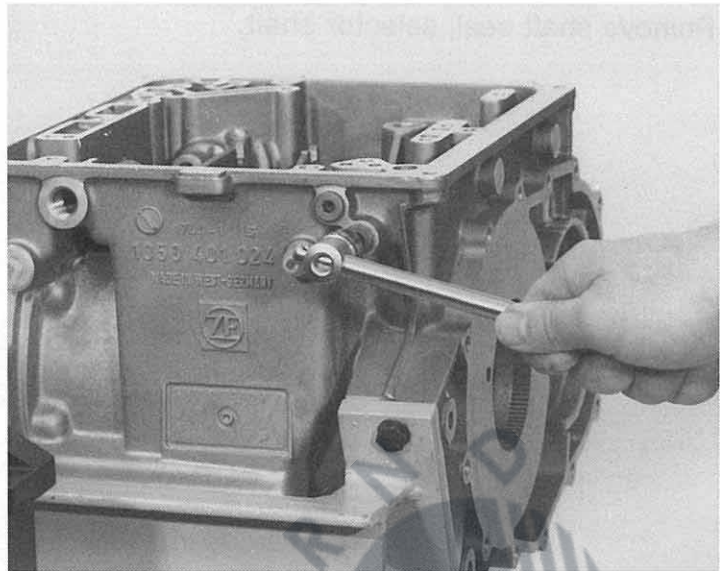

Locating pin and tube (outer turbo feed) normally remain in the transmission housing.

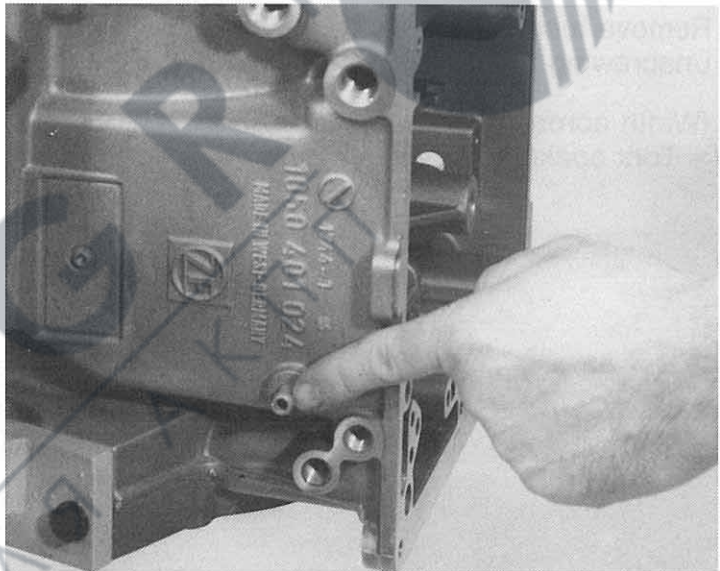

3. Assembly

3.1 Transmission housing with selector mechanism and parking interlock

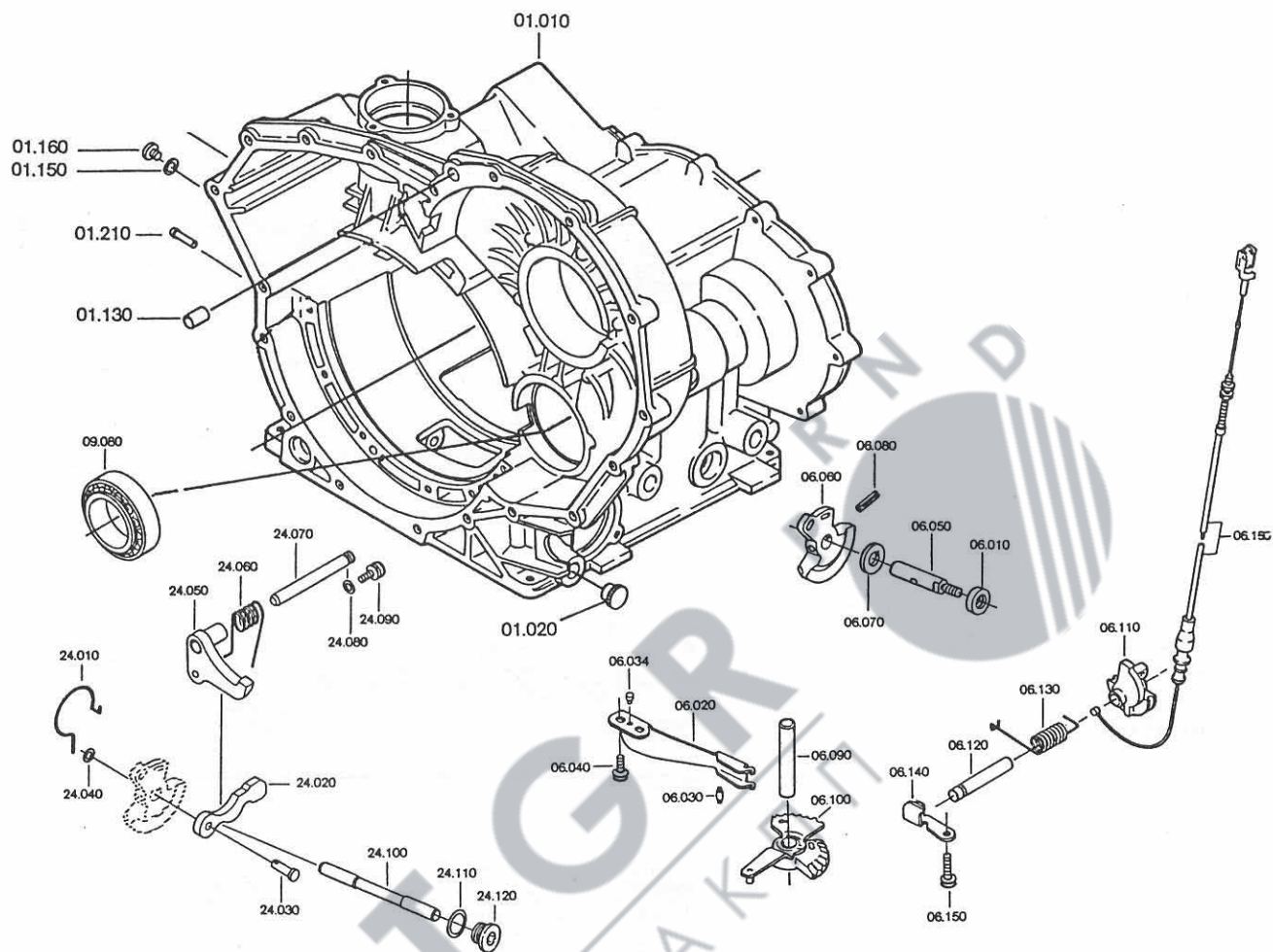

85 192

On the turbo version, first carefully knock the tube 01.210 (turbo pressure feed) into the transmission housing 01.010 as far as it will go with the plastic-headed hammer.

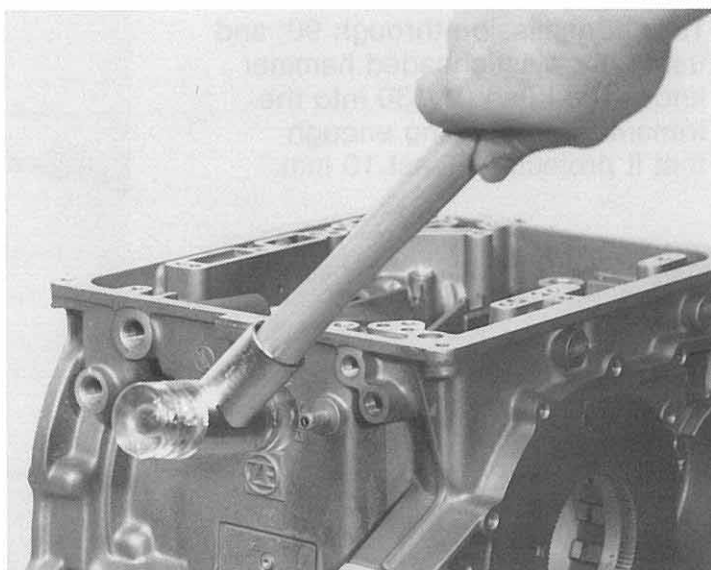

85 193

Fit the screw plugs 01.160 with new seals 01.150.

(Width across flats of hexagon socket = 5 mm)

(Tightening torque = 15 Nm)

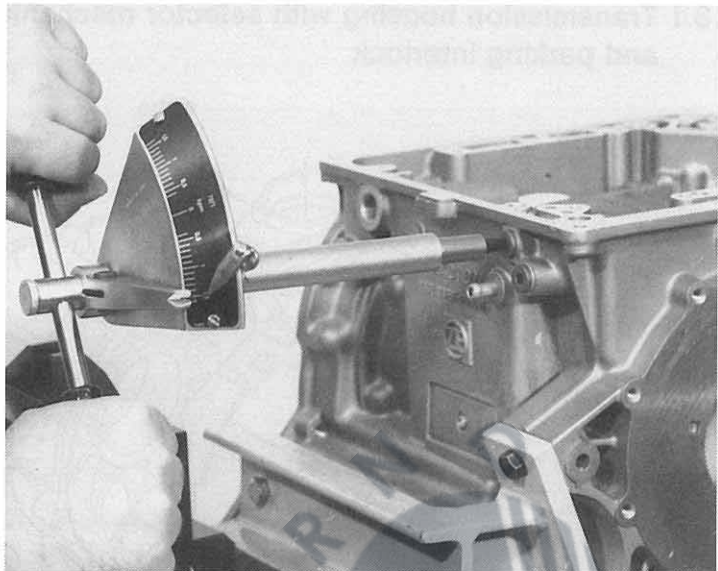

85 194

Screw the two plastic plugs 01.020 into the oil cooler line connection holes found on both sides.

(Tightening torque = n.a.)

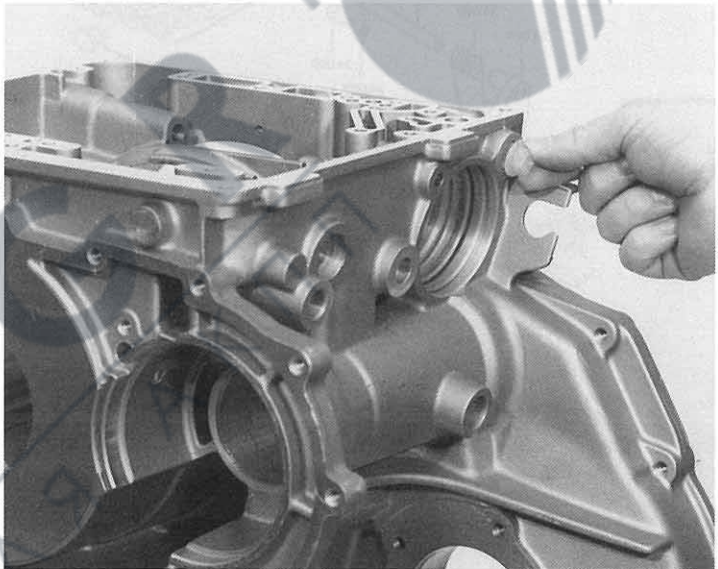

85 195

Turn transmission through 90° and using the plastic-headed hammer knock the bush 01.130 into the transmission housing enough that it projects at least 10 mm.

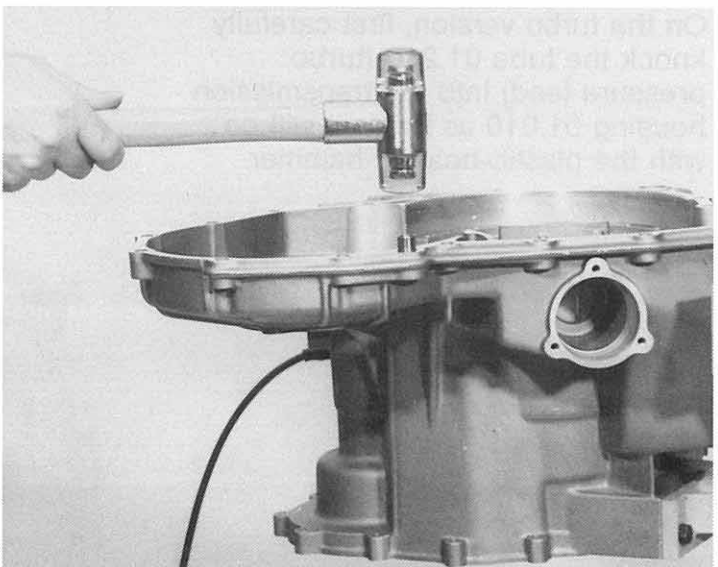

85 197

It is recommended the transmission housing be heated to approx. 70° C in order to install the tapered roller bearing outer rings.

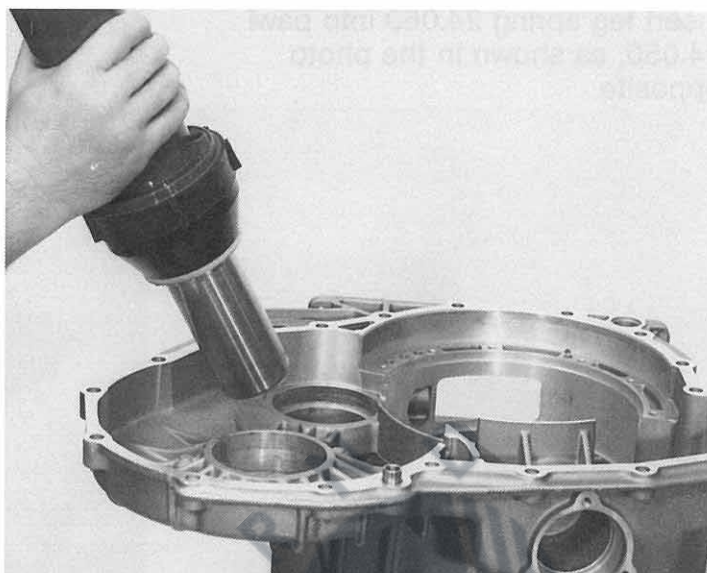

85 198

Insert outer ring of tapered roller bearing 09.080 (counter shaft) as far as it will go.

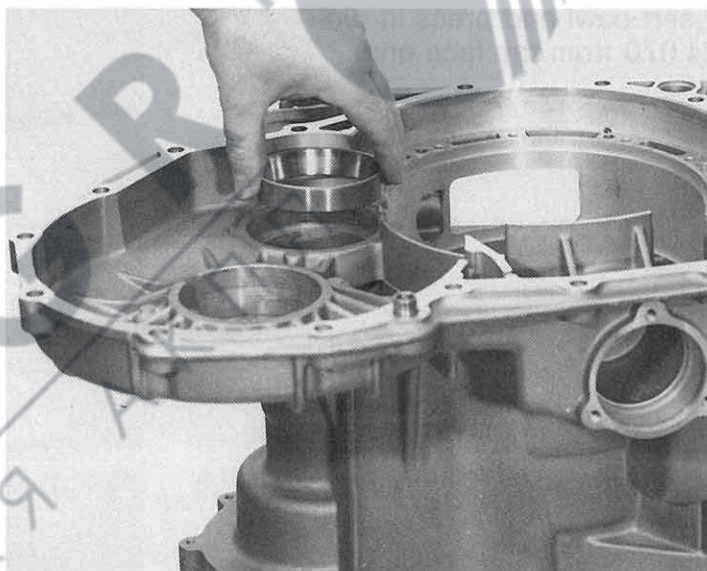

85 199

Coat new shaft seal 06.010 with grease (Vaseline) and knock it in with mounting mandrel 5 X 46 000 187.

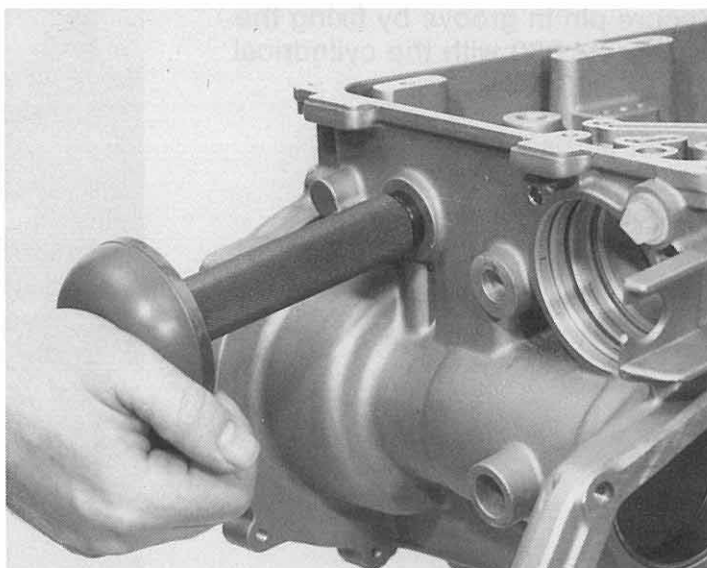

85 200

Insert leg spring 24.060 into pawl 24.050, as shown in the photo opposite.



85 201

Insert pawl and press in pin 24.070 from the face end.

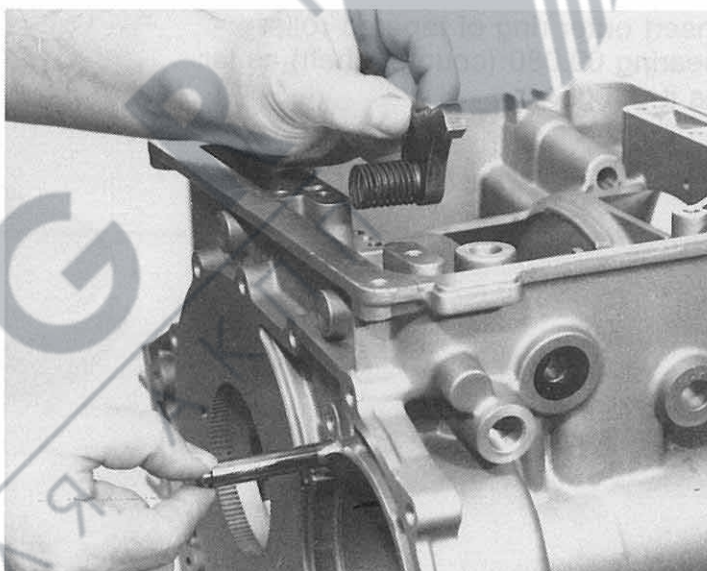

85 202

Secure pin in groove by fixing the washer 24.080 with the cylindrical bolt 24.090.

(Width across flats
= Torx socket – TX 27)
(Tightening torque = 10 Nm)

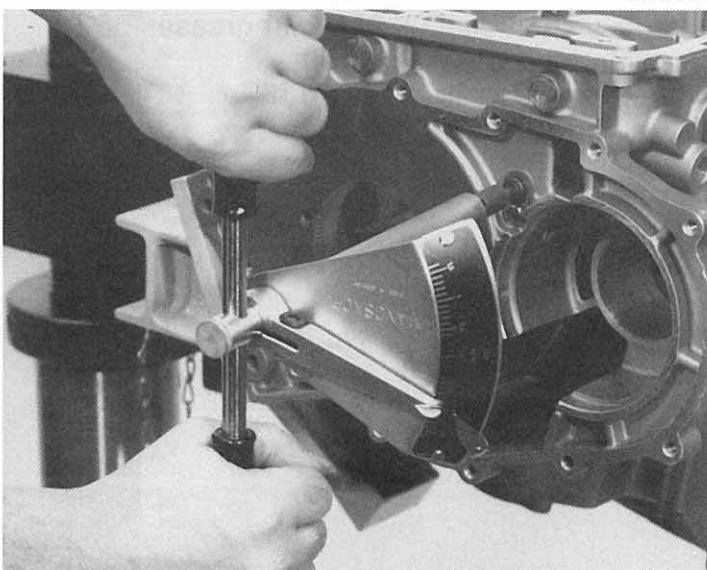

85 203

Complete segment 06.060 by fitting locking cam 24.020 by first of all inserting the pin 24.030 into the locking cam in such a way that the head is pointing to the left, the centre convex to the top and the boss of the cam is on the right.

Caution!

It is essential to adhere to this position.

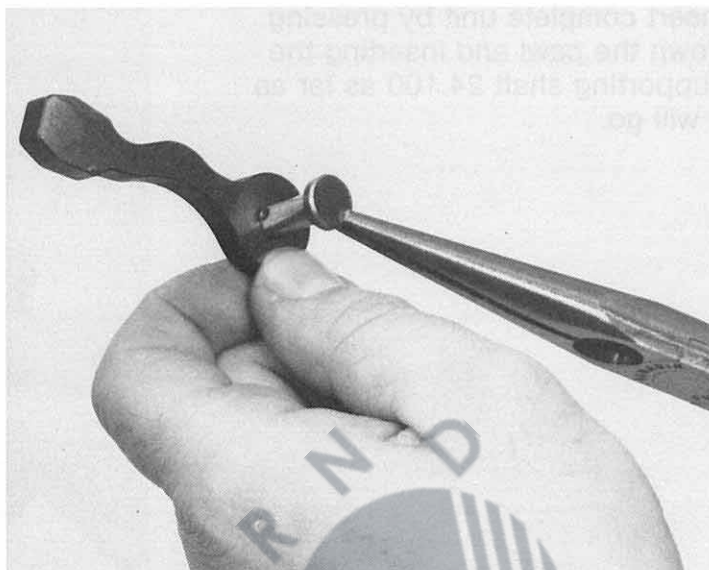

85 204

Insert pin together with locking cam in segment, turn round fully and slip over washer 24.040.

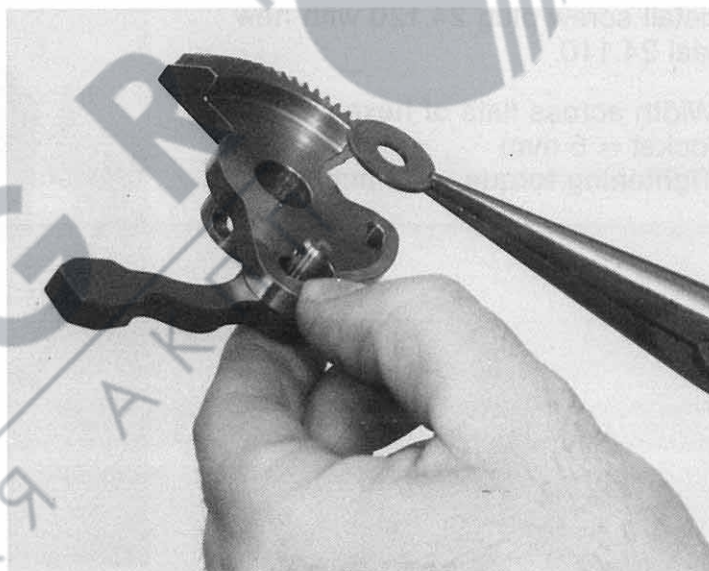

85 205

Following this, insert spring clip 24.010 through pin and attach in segment.

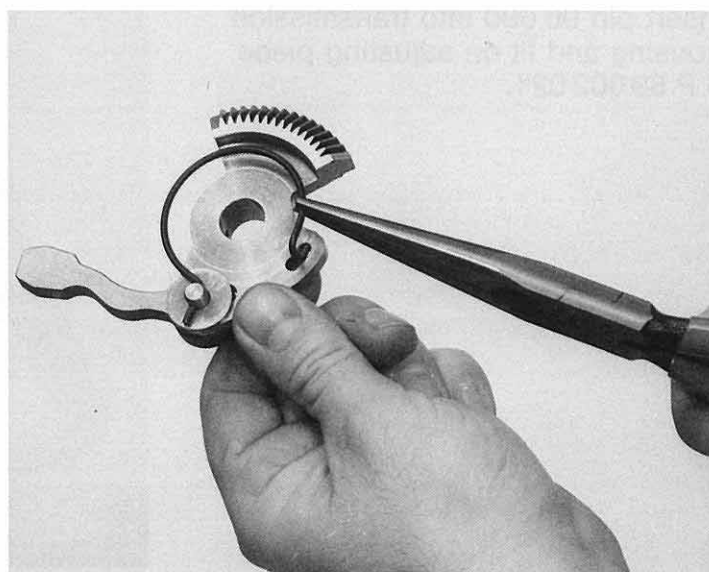

85 206

Insert complete unit by pressing down the pawl and inserting the supporting shaft 24.100 as far as it will go.

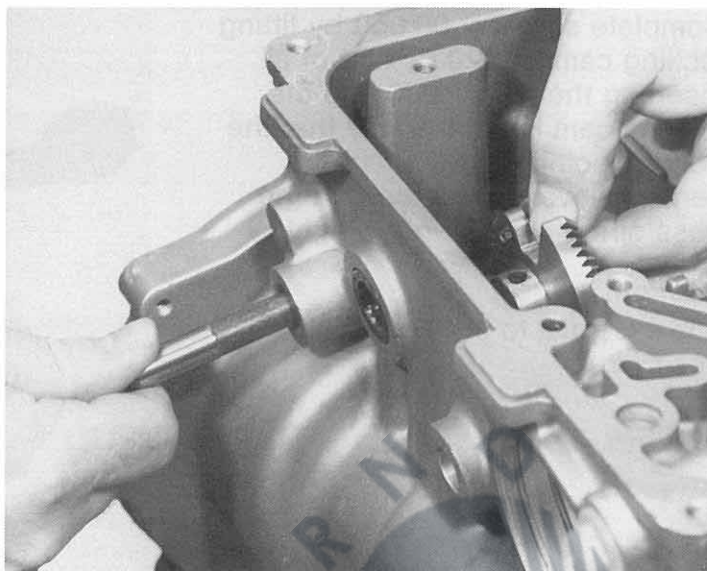

85 207

Install screw plug 24.120 with new seal 24.110.

(Width across flats of hexagon socket = 6 mm)
(Tightening torque = 32 mm)

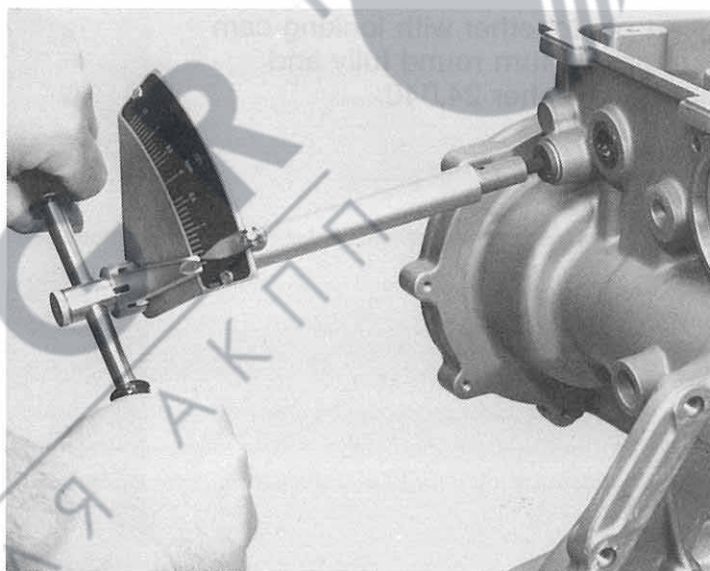

85 208

Insert pin 06.090 into transmission housing and fit on adjusting piece 5 P 89 002 021.

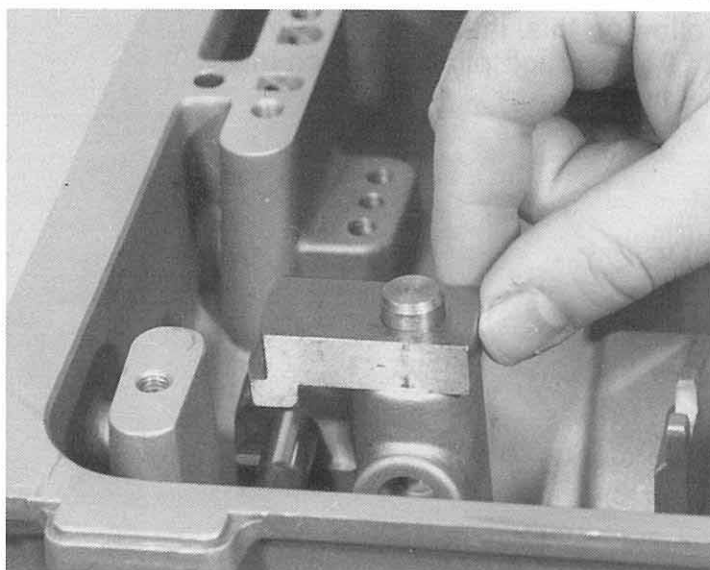

85 209

Use the plastic-headed hammer to knock the roller 06.030 into the detent spring 06.020.

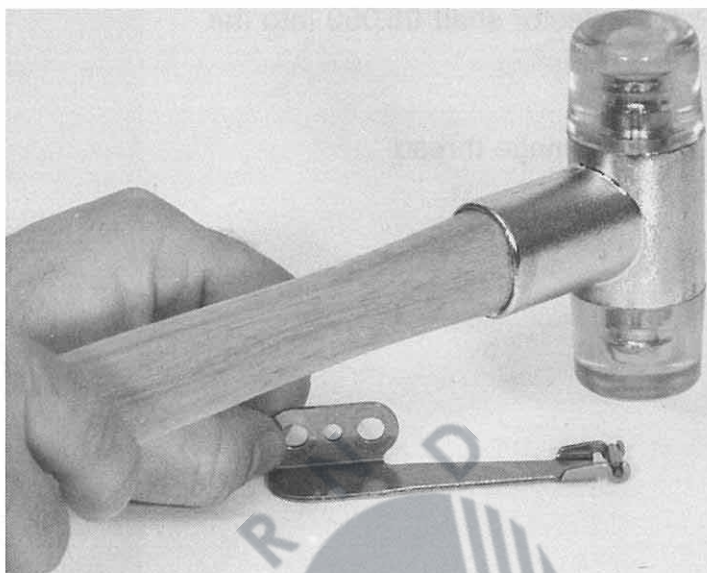

85 210

Press pin 06.034 to fix in housing, then fit on detent spring.

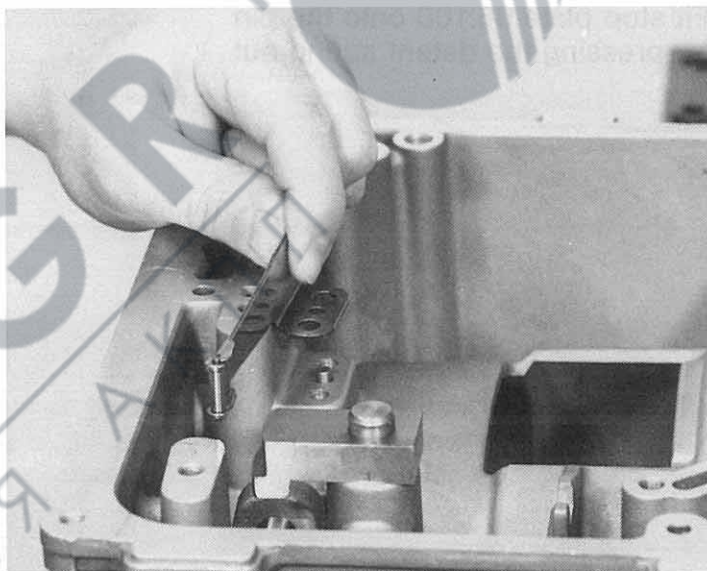

85 211

Press detent spring against adjusting piece and fix in this position with two cylindrical bolts 06.040.

(Width across flats
= Torx socket - TX 27)
(Tightening torque = 10 Nm)

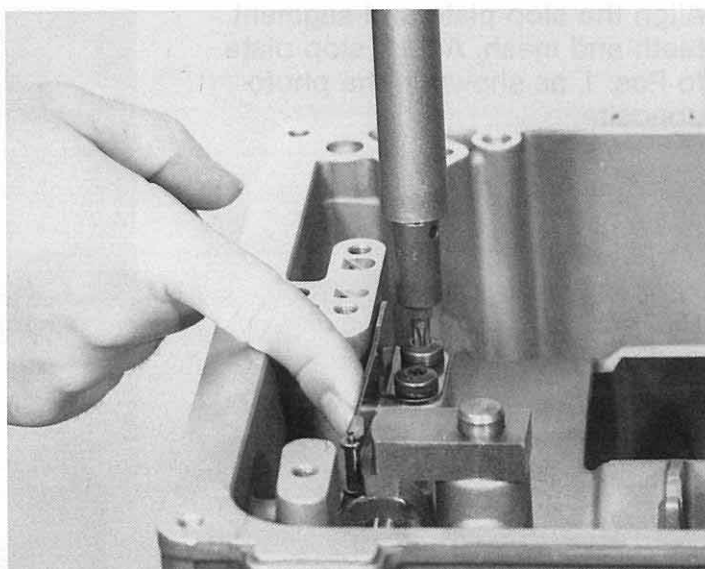

85212

Press selector shaft 06.050 into the segment.

Caution!

Do not damage thread.

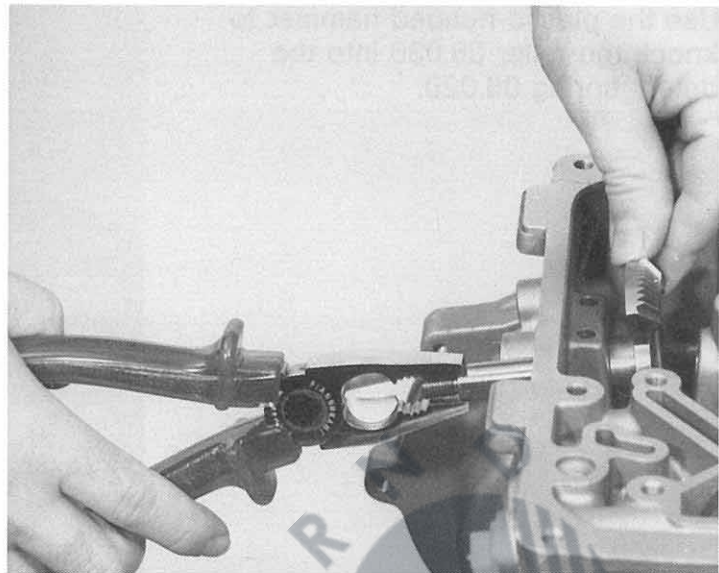

85213

Fit stop plate 06.100 onto the pin by pressing the detent spring out.

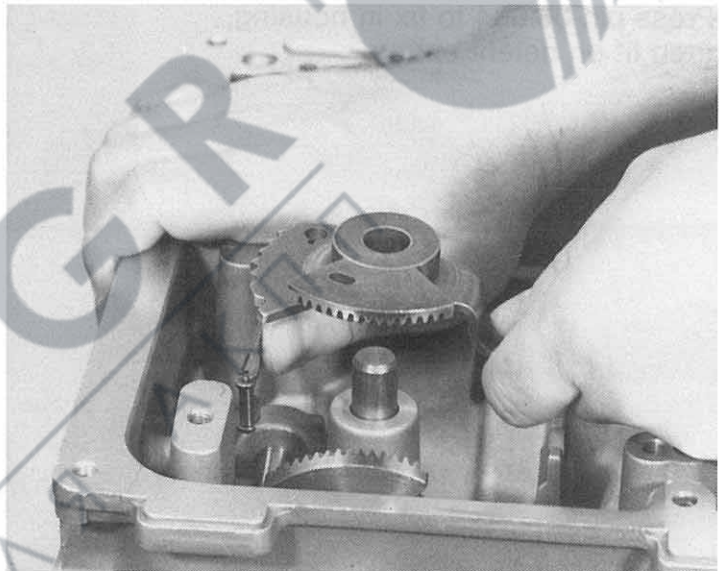

85214

Align the stop plate and segment teeth and mesh. Adjust stop plate to Pos. 1, as shown in the photo opposite.

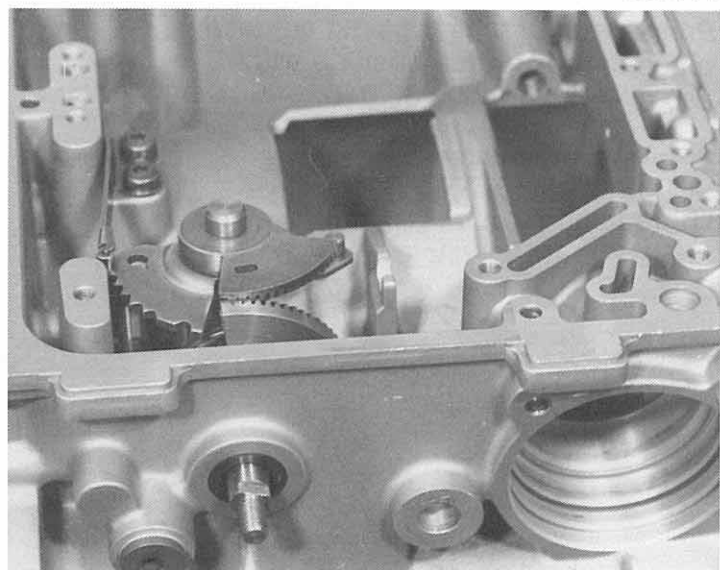

85215

Important!
Adjustment

The thicknesses of the washer(s) 06.070 have to be determined (refer to Point 1.4.1., p. 5/1)

Install washer(s) between segment and housing. This is done by removing the stop plate again and withdrawing the selector shaft far enough out.

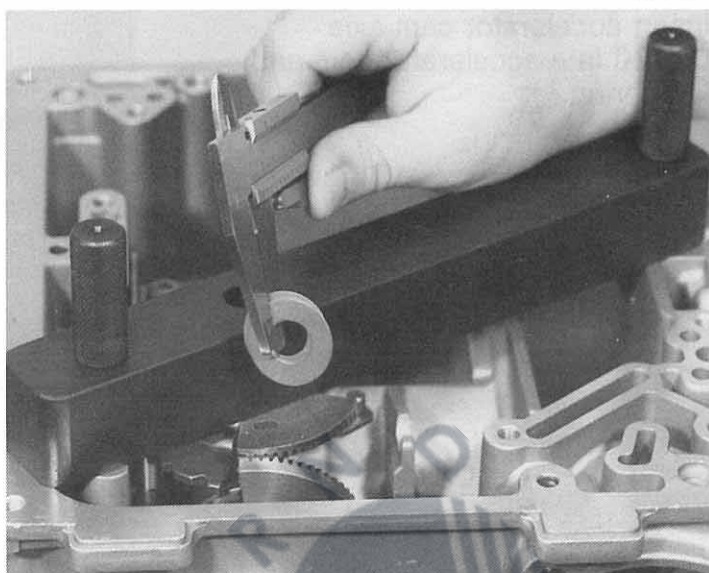

85218

Use tool 5 X 46 000 291 or a suitable mandrel to knock tension pin 06.080 into the position where the open side is positioned at right angles to the selector shaft.



85219

Attach leg spring 06.130 into accelerator cam, as shown in the photo opposite.

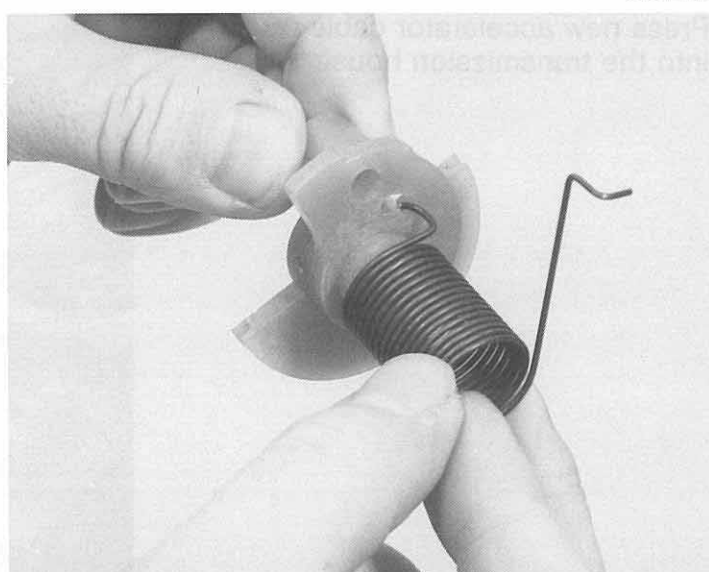

85 220

Insert accelerator cam axle 06.120 into accelerator cam and leg spring.

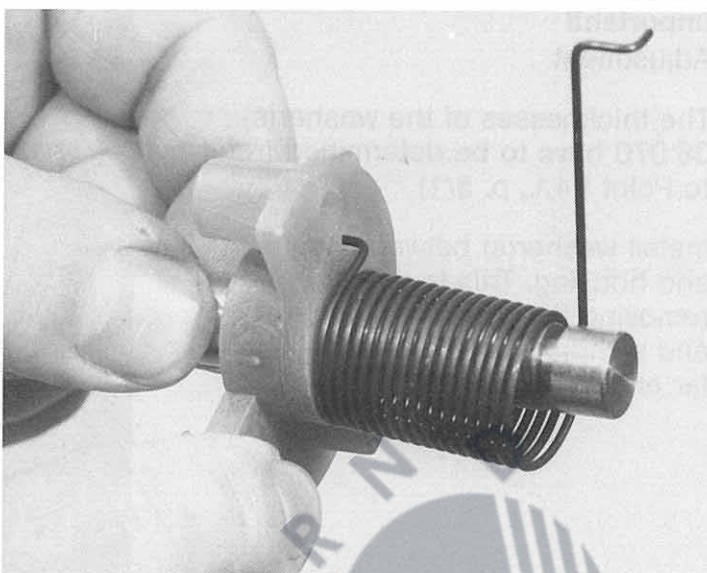

85 221

Install the complete unit. Insert retaining plate 06.140 into the annular groove of the accelerator cam axle and fix it in place with cylindrical bolt 06.150.

(Width across flats = Torx socket - TX 27)
(Tightening torque = 10 Nm)

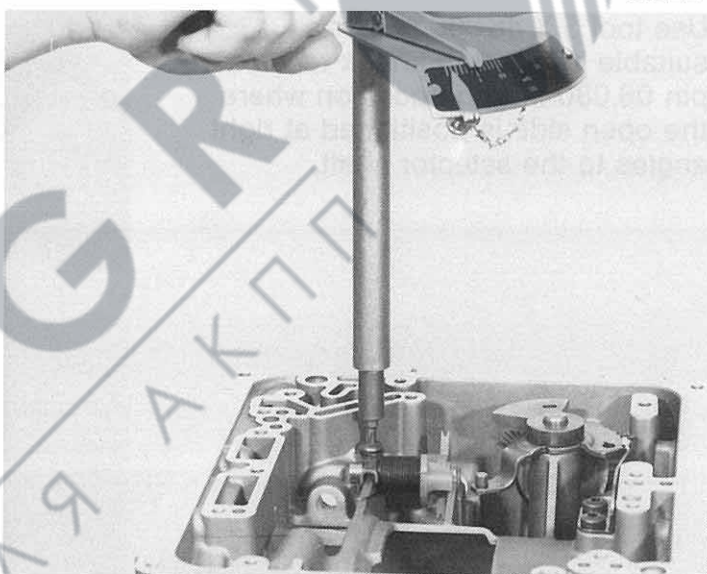

85 222

Press new accelerator cable 06.160 into the transmission housing.

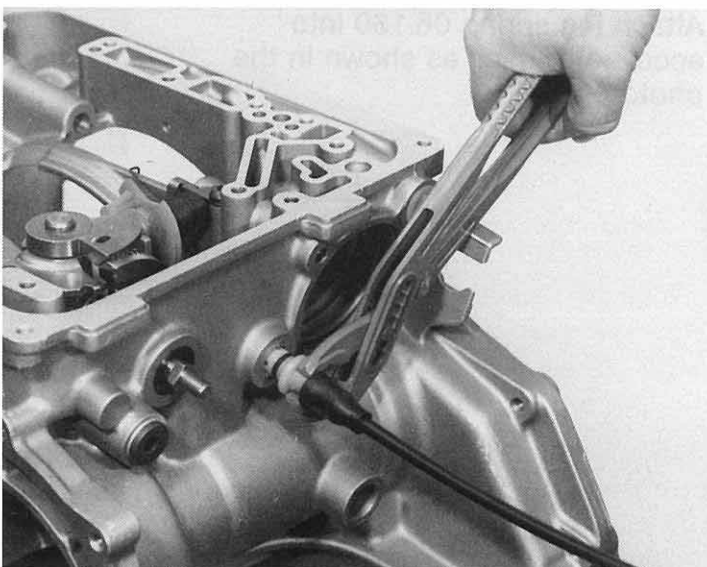

Pretension accelerator cam by rotating one revolution and attach nipple of cable in accelerator cam.

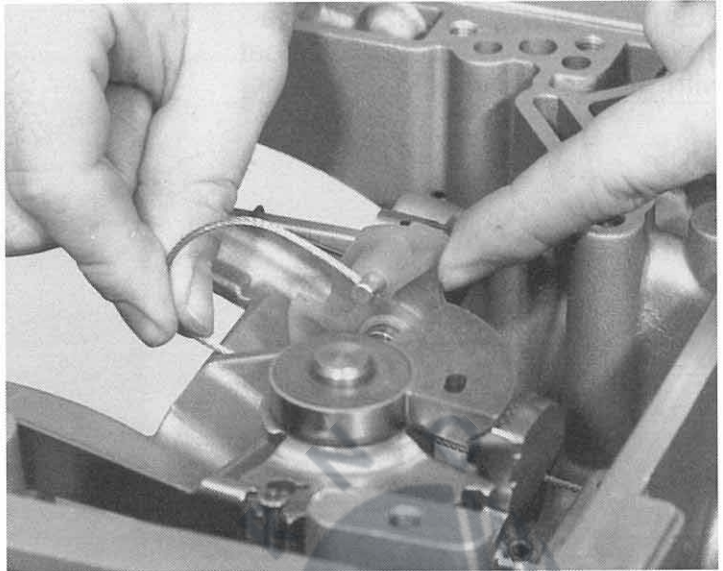

3.2 Brake 'C

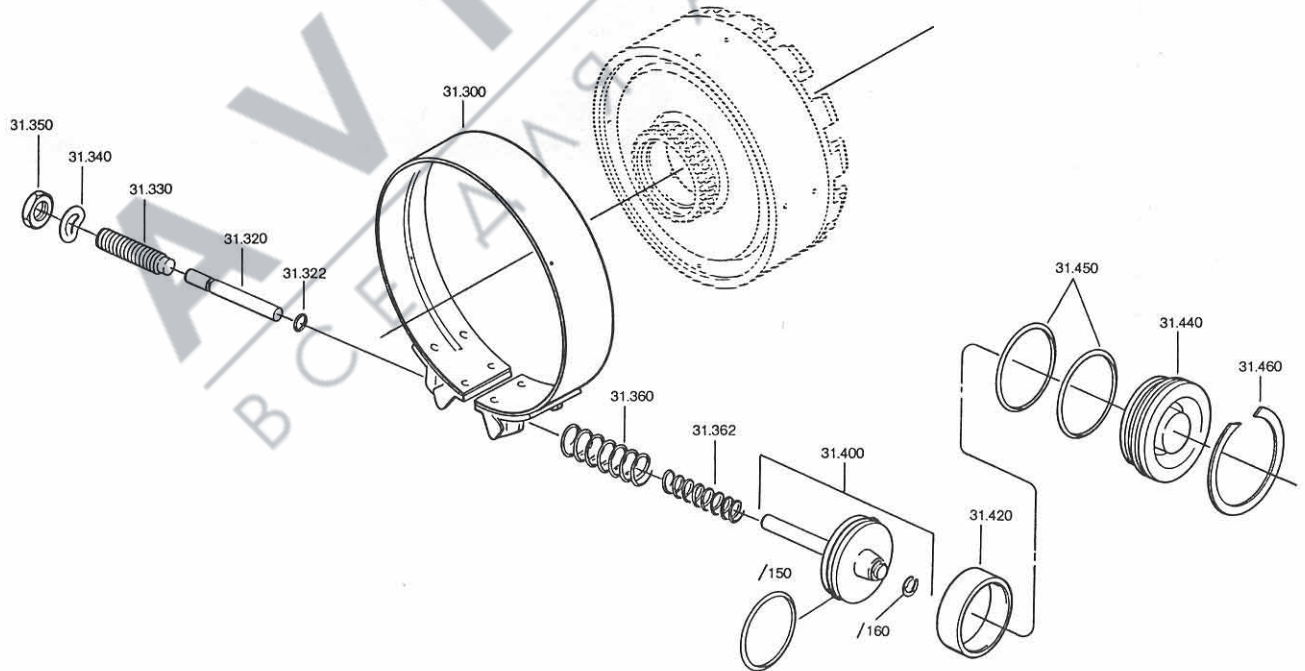

85 224

Push new O ring 31.322 into the groove of the pin 31.320 and coat with grease (Vaseline).



85 225

Insert pin into housing in such a way that the O ring provides a seal to the outside of the housing. Complete adjusting bolt 31.330 by fitting spring washer 31.340 and hexagon nut 31.350. Screw halfway into housing.

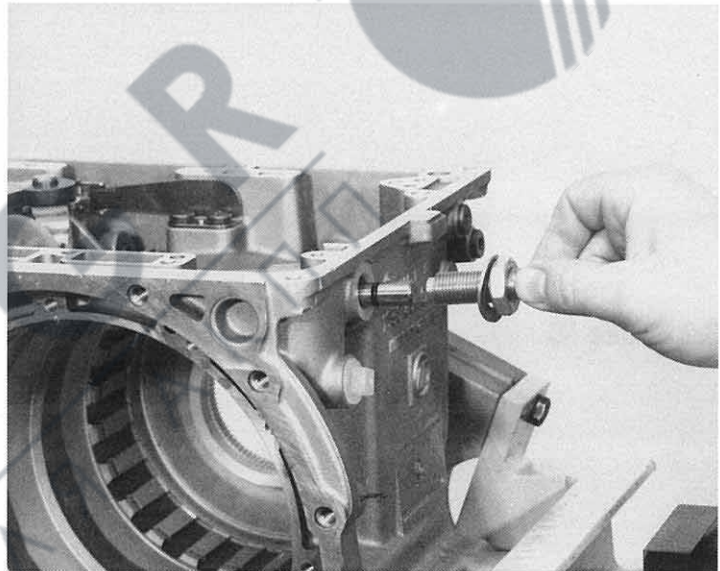

Piston C' 31.400 is fitted with different components according to the version.

If the piston has been partially disassembled, it should be assembled as shown in the sketch opposite.

If the washers are of different thickness, install the thicker one against the collar of the pin.

The O ring 31.400/150 should always be renewed; the locking ring 31.400/160 as necessary.

Version 1

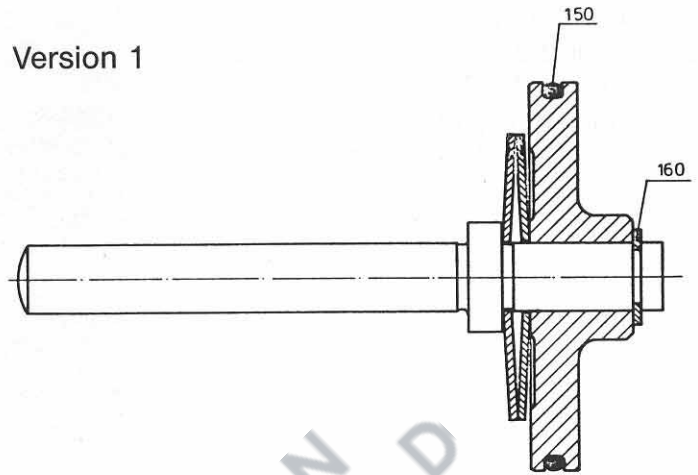

Version 2

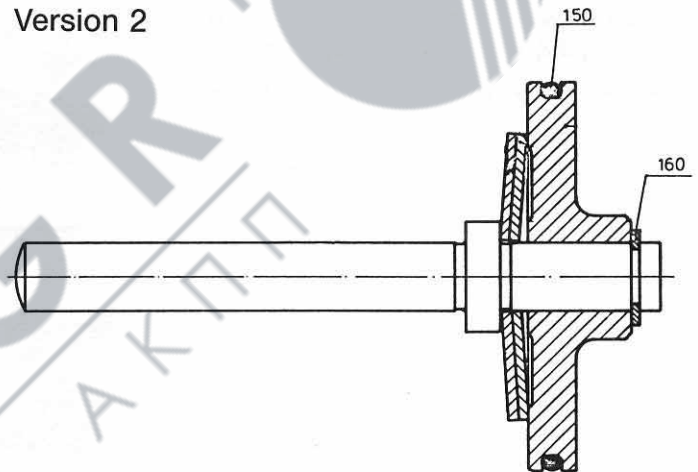

Caution!

With a different transmission version, the sleeve 31.420 has to be inserted additionally in the transmission housing using the mandrel 5 X 46 000 267.

85 226

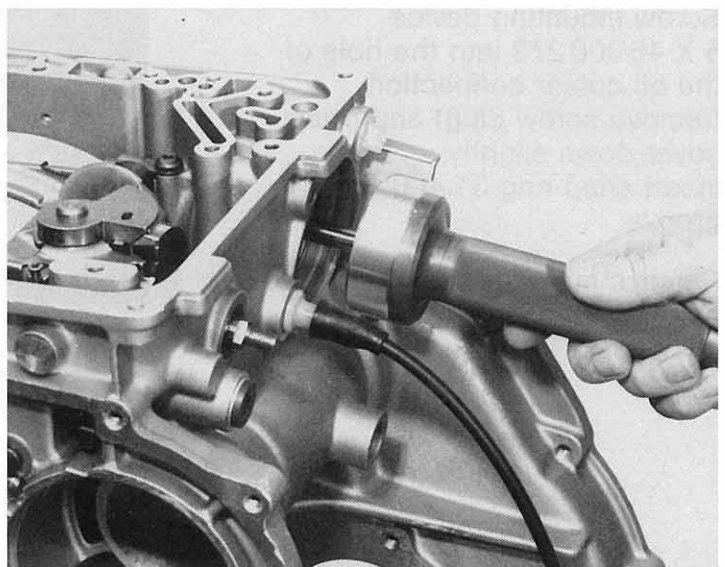

85 227

Slip the compression springs 31.360 and 31.362 over the piston rod, apply a light coating of grease (Vaseline) to O ring and insert complete unit in housing.

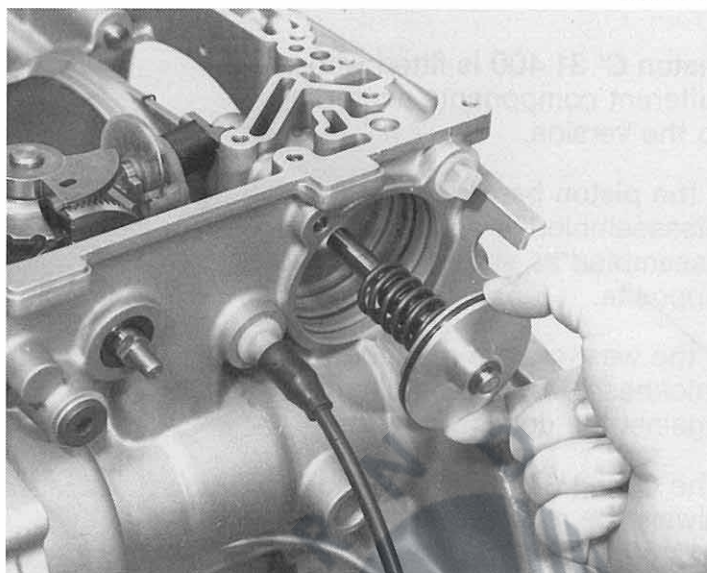

85 228

Fit two new O rings 31.450 onto the cover 31.440, apply a light coating of grease and press into the housing.

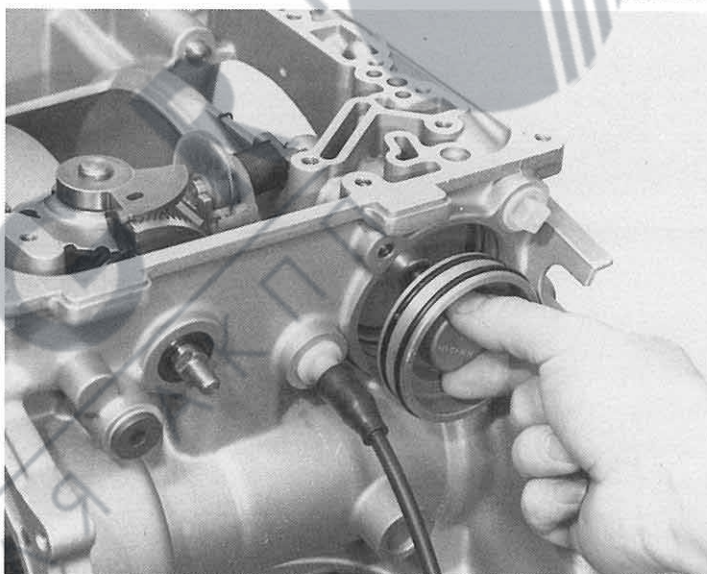

85 229

Screw mounting device 5 X 46 000 273 into the hole of the oil cooler connection (remove screw plug) and press cover down slightly. Insert snap ring 31.460 into the groove.

Remove mounting device and re-fit screw plug.

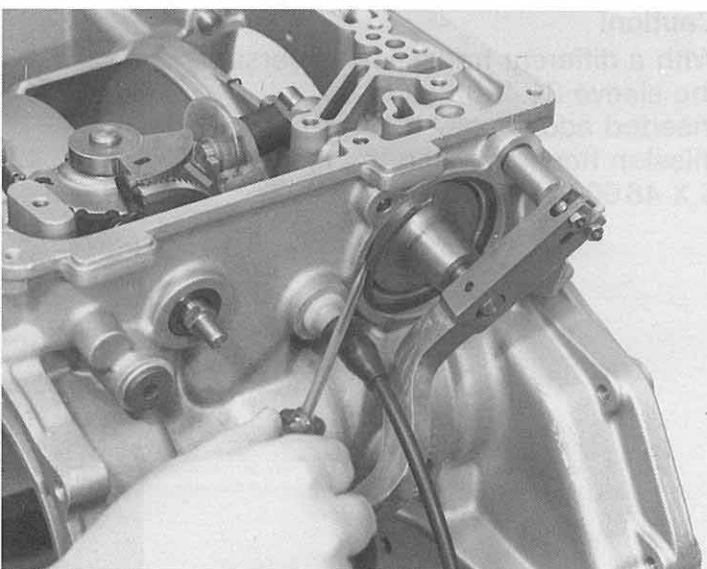

Turn transmission through 90°.

Slightly compress brake band 31.300 and fit the lugs into the two pins.

Pay attention to the shoulder in the transmission housing.

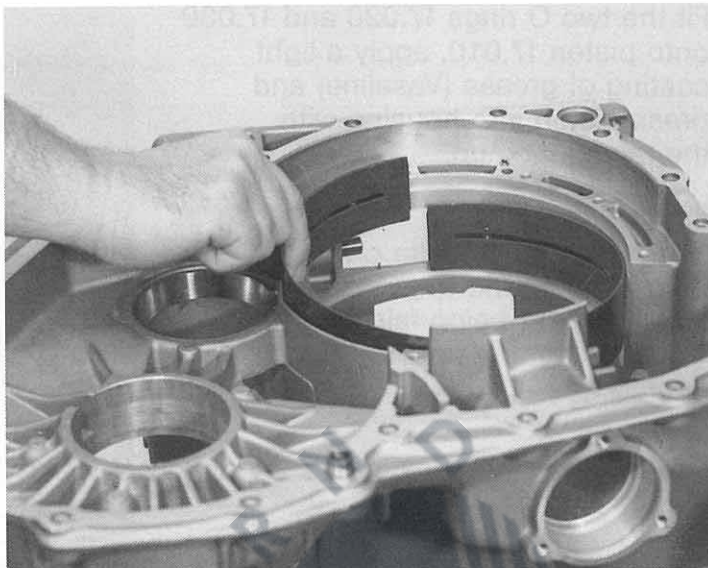

3.3 Brake D with 1st speed freewheel

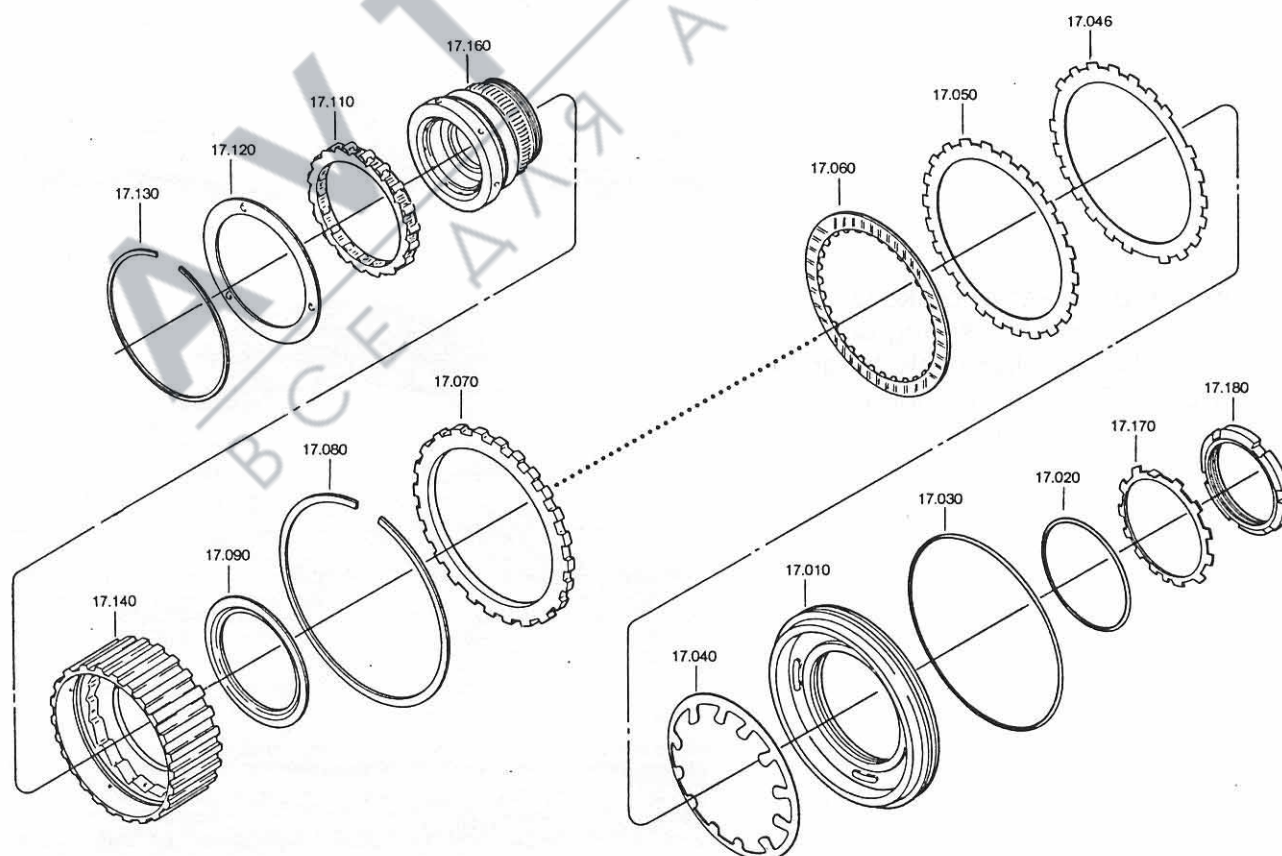

85 231

Fit the two O rings 17.020 and 17.030 onto piston 17.010, apply a light coating of grease (Vaseline) and press piston into housing with the raised face up.

Important!

The piston must make proper contact all round to avoid the measurement being falsified. Use a suitable mandrel to drive it in if necessary.

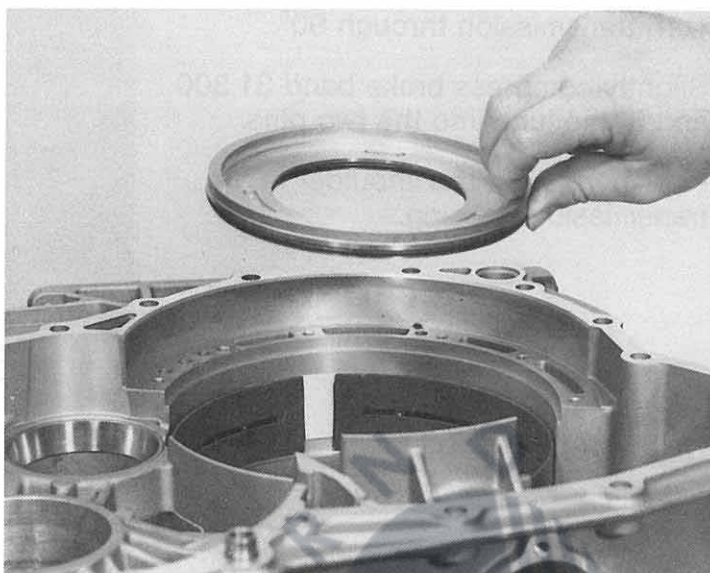

85 232

Insert plate spring 17.040 and retaining washer 17.090.

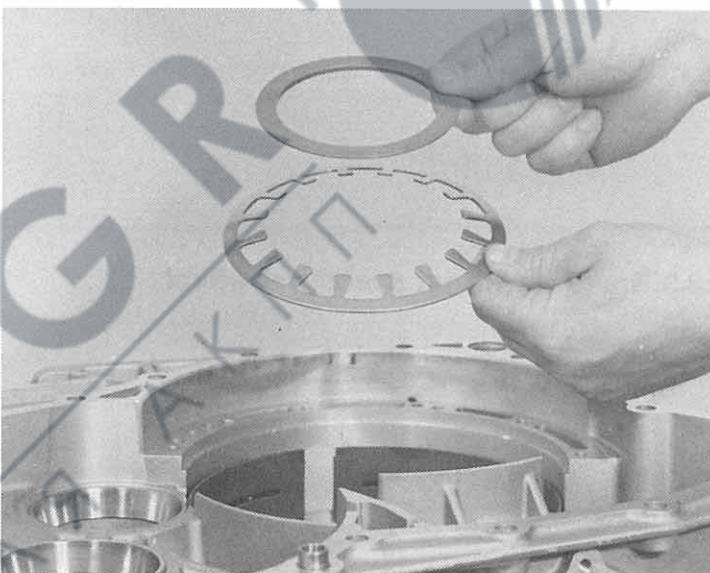

85 234

Insert complete set of brake D discs. Begin with the spring disc 17.046, followed alternately by an outer disc 17.050 and a lined disc 17.060. Fit on end disc 17.070 and secure with snap ring 17.080.

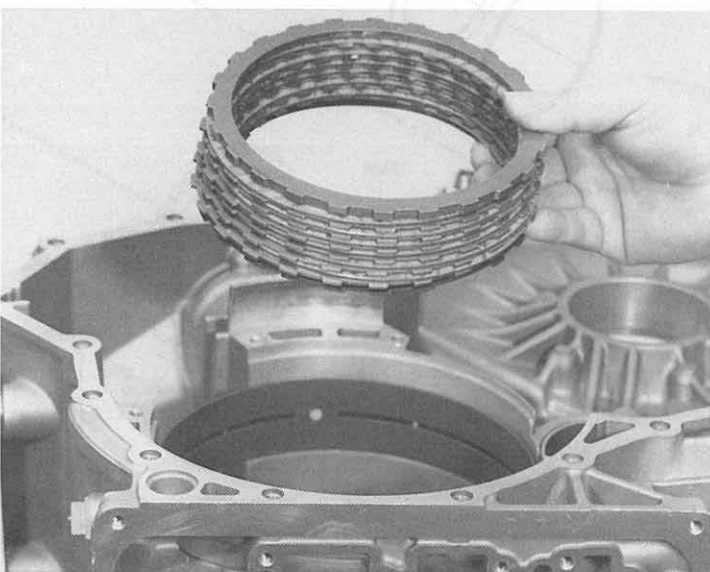

Important!
Adjustment

The thickness of the snap ring has to be determined.
(refer to Point 1.4.2, p. 5/2).

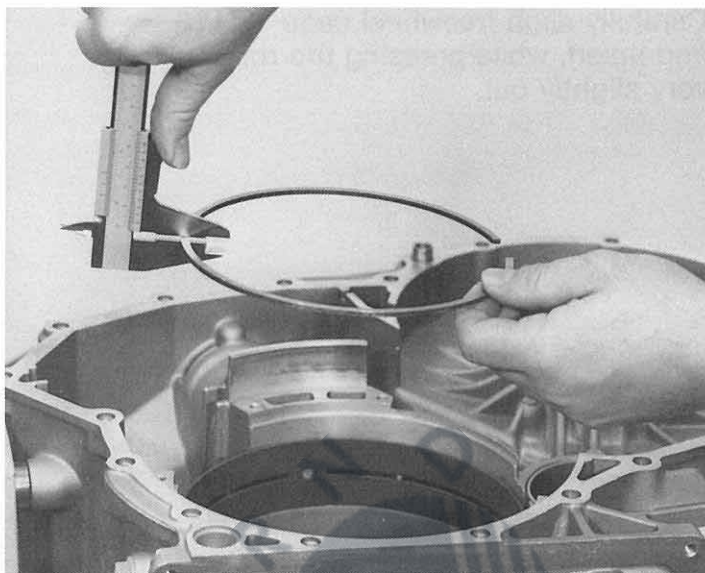

Place freewheel outer ring 17.140
on a suitable base, e.g. screw-in
aid 5 X 46 000 305.

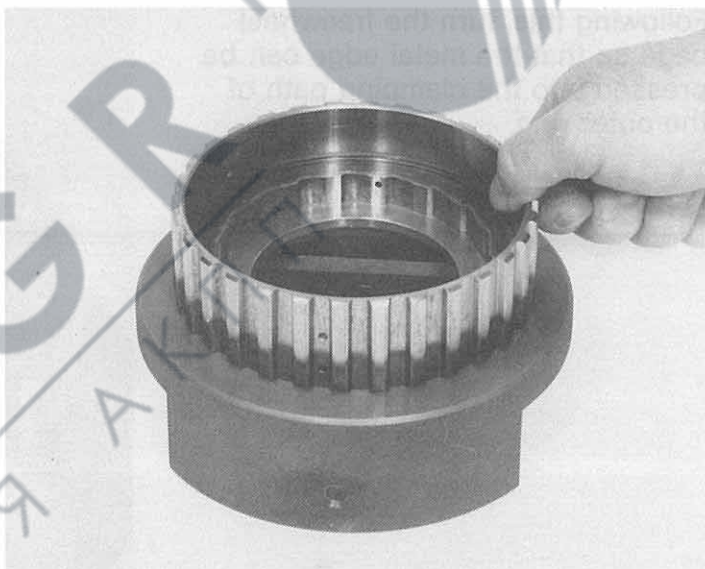

Press freewheel inner ring 17.160
into outer ring.

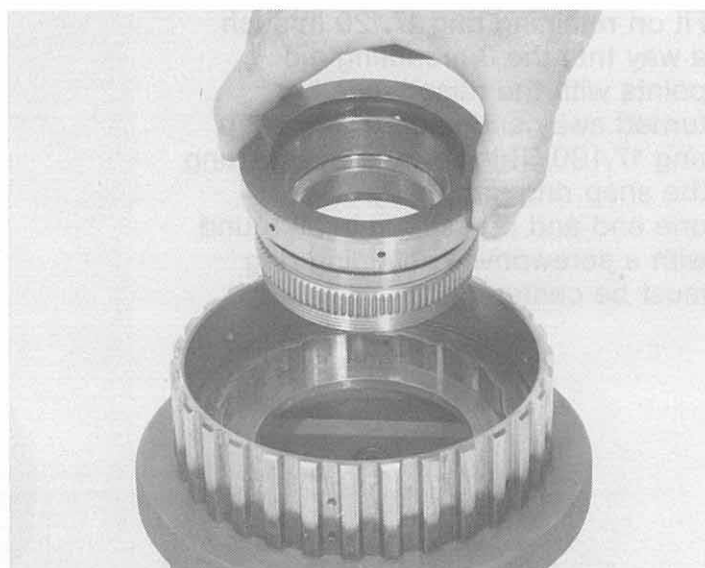

Carefully align freewheel cage 17.110 and insert, while pressing the rollers very slightly out.

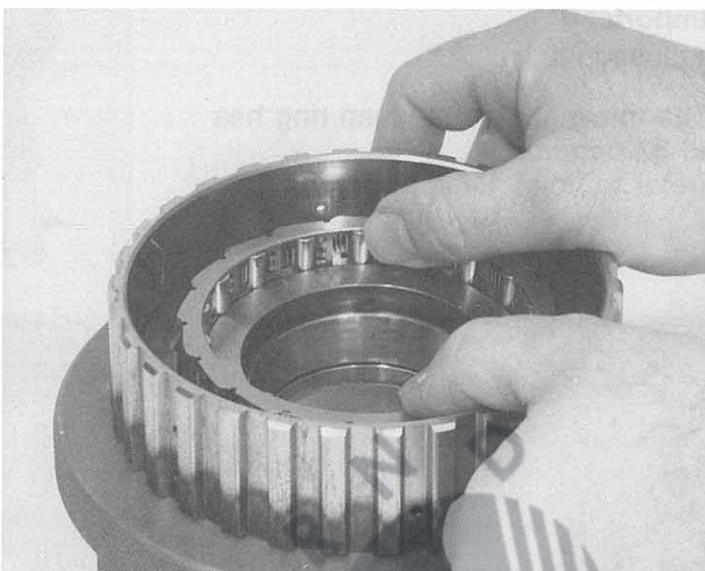

Following this, turn the freewheel cage so that the metal edge can be pressed into the clamping path of the outer ring.

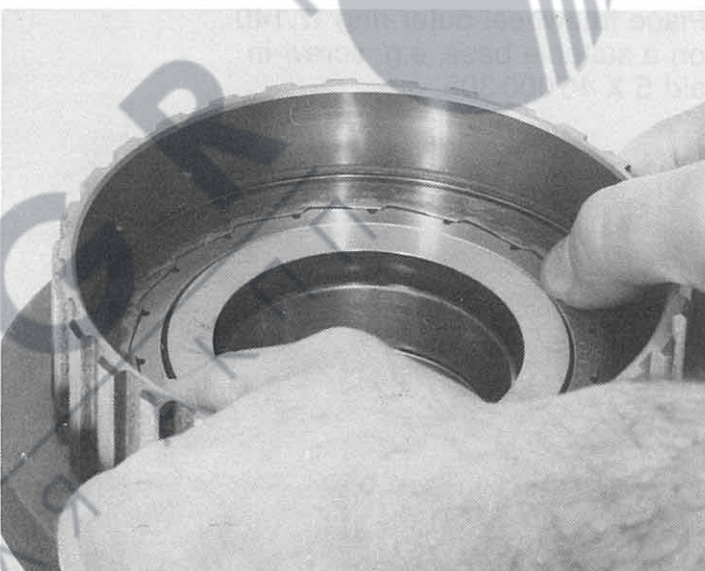

Fit on retaining ring 17.120 in such a way that the 3 mounting aid points with the raised face are turned away and secure with snap ring 17.130. This is done by inserting the snap ring into the groove at one end and pressing it in all round with a screwdriver (retaining ring must be centered).

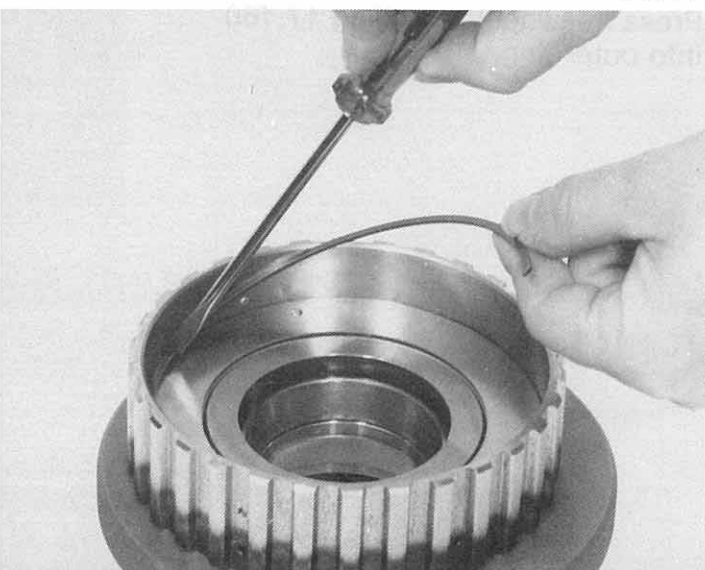

85 242

Assembly is simplified by again removing the brake D disc set and inserting 1st gear freewheel into the gearing in the transmission housing.

Ensure that the inner ring of the freewheel is not pressed out.

Turn transmission through 90° while holding freewheel in position.

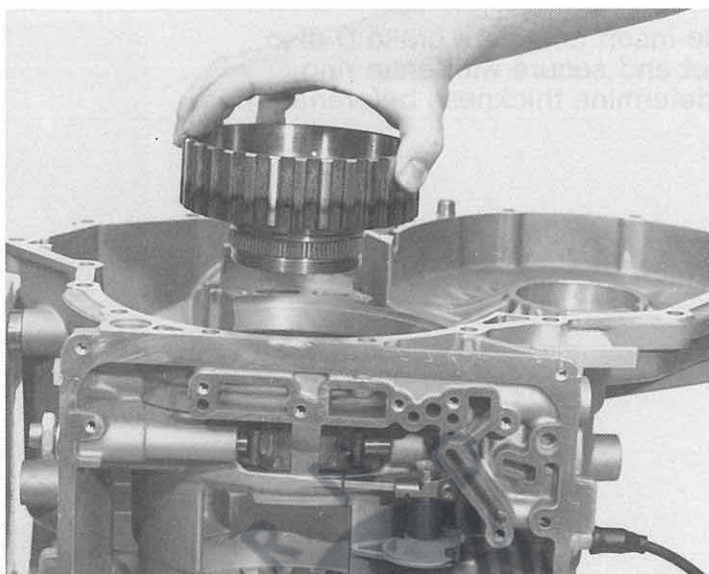

85 243

Engage tab washer 17.170 with its locking lug in the transmission housing. Screw on slotted nut 17.180 and tighten with slotted nut wrench 5 X 46 000 155.

(Tightening torque = 50 Nm)

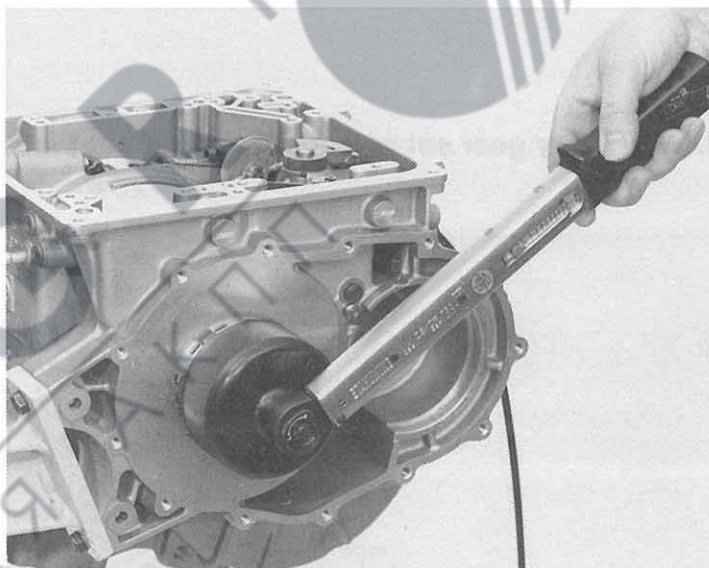

85 233

Caulk tab washer with a suitable mandrel.

Turn transmission through 90°. Perform operational check of freewheel – turns freely in clockwise direction.

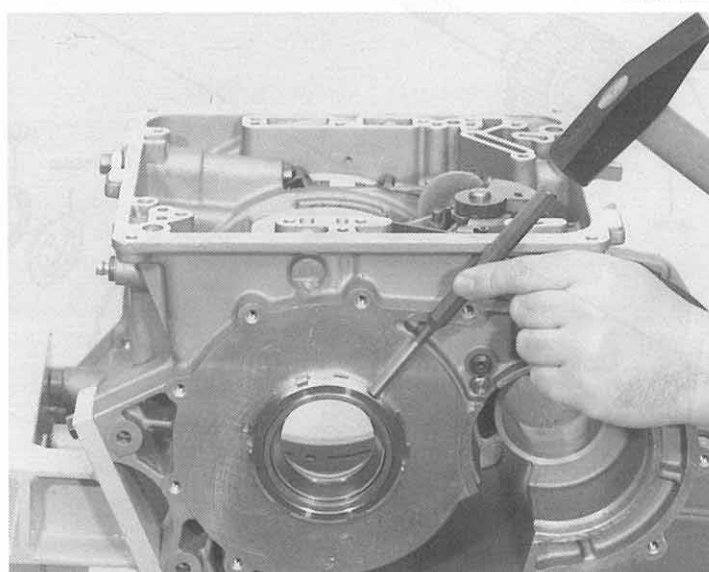

Re-insert complete brake D disc set and secure with snap ring (determine thickness beforehand).

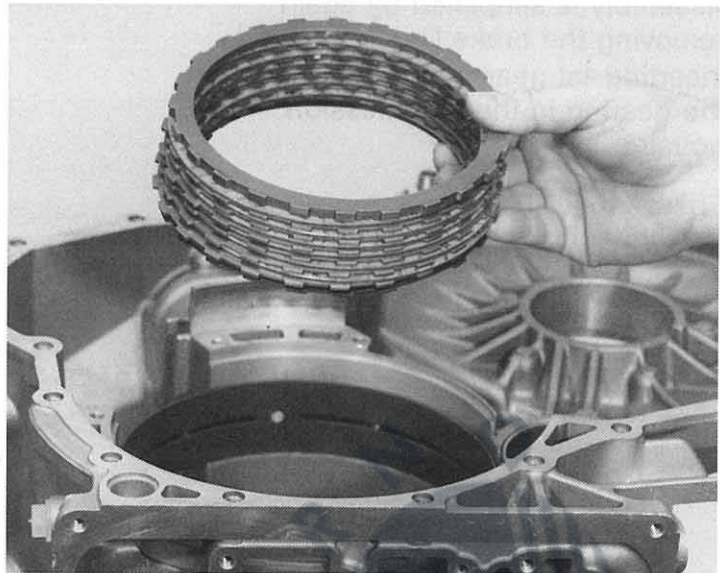

3.4 Planetary gear set with input and output parts

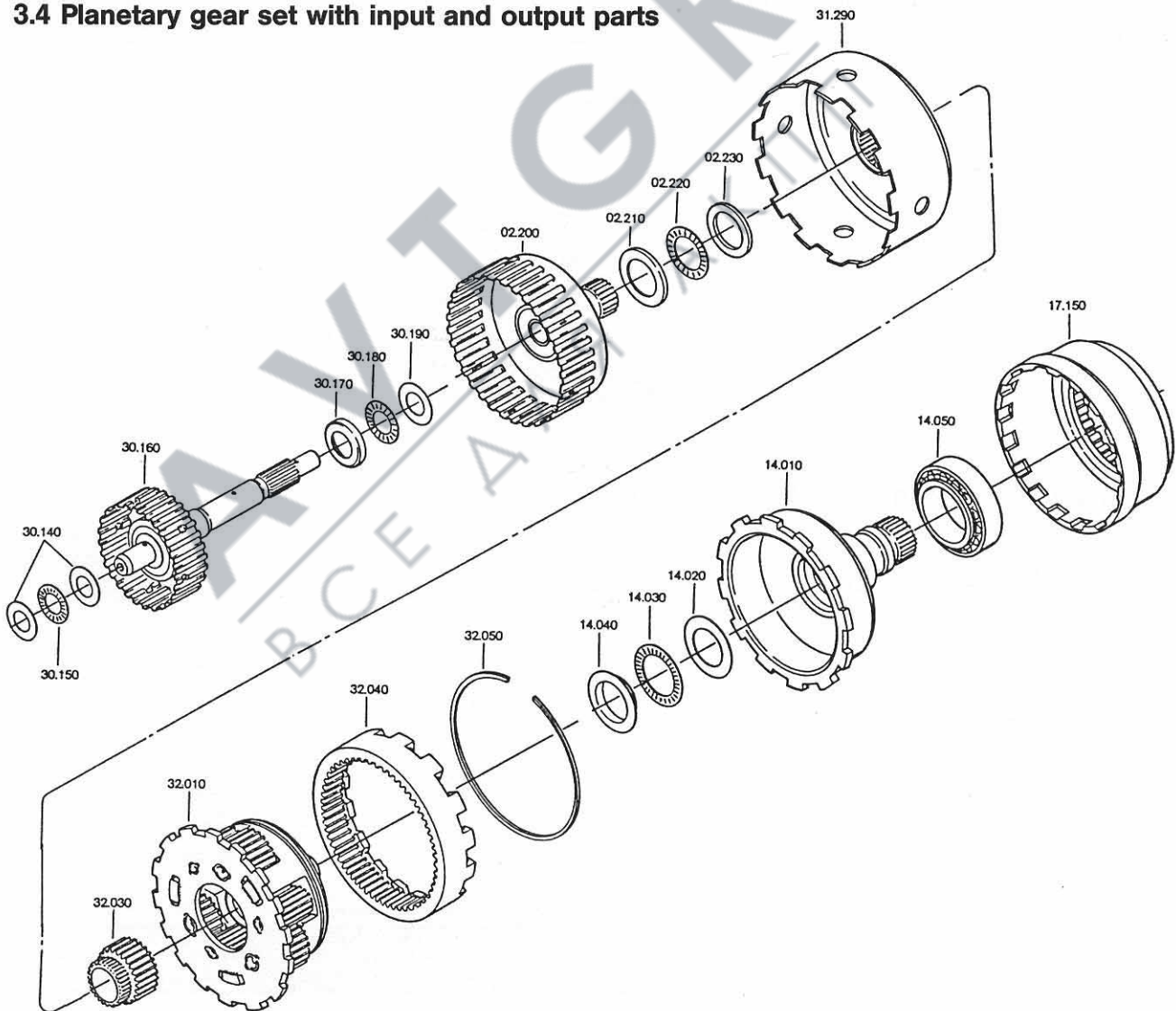

85 246

Mount spider bowl 17.150 onto the freewheel inner ring.

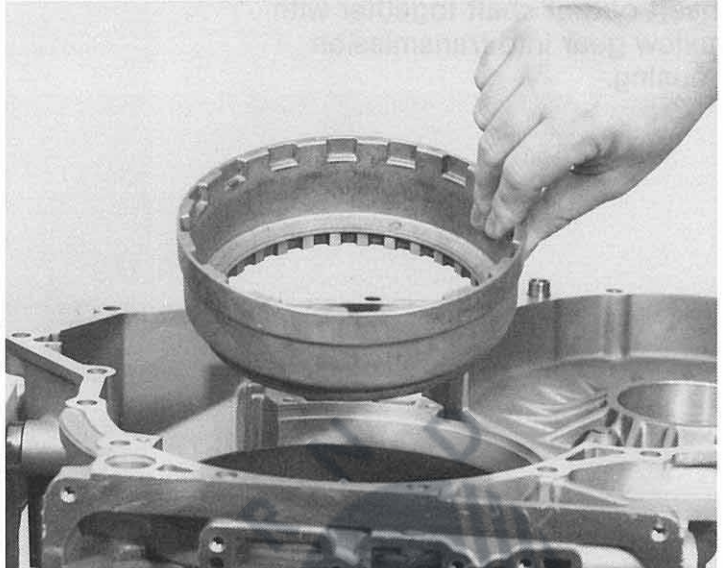

85 247

Press the tapered roller bearing inner ring 14.050 onto the output shaft 14.010 under the mandrel press using the mounting sleeve 5 X 46 000 300.

Use a suitable base when performing this step to support the shaft.

Caution!

Do not place on metal edge.



85 248

Insert output shaft into hollow gear 32.040 and secure with snap ring 32.050.

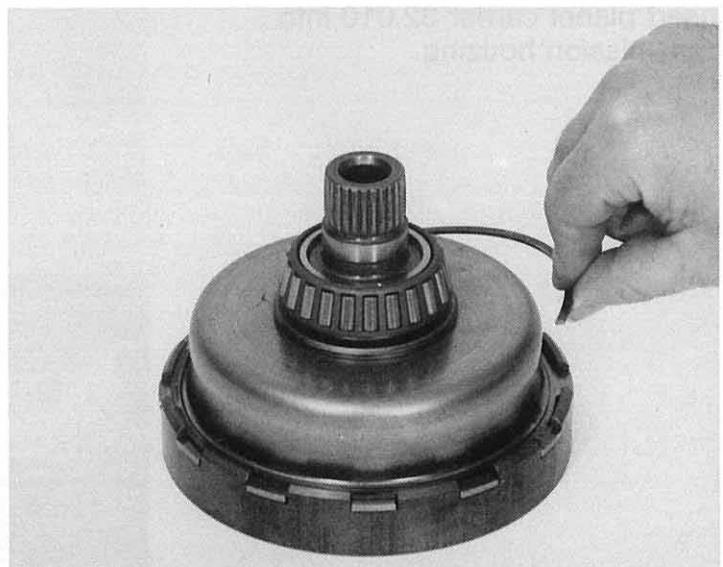

85 249

Insert output shaft together with hollow gear into transmission housing.

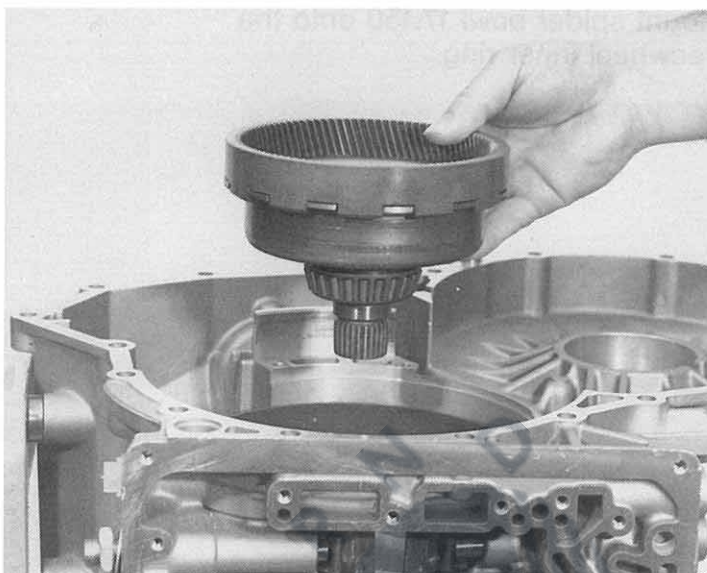

85 250

Install axial washer 14.020, axial bearing 14.030 and angle washer 14.040.

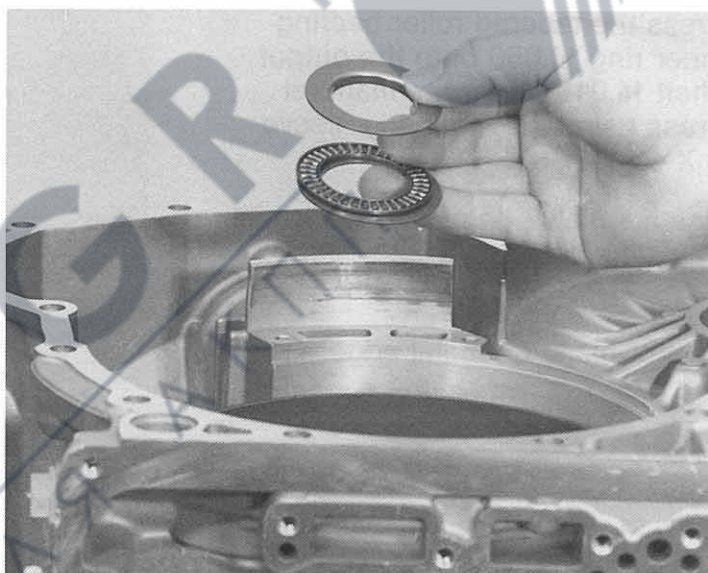

85 251

Insert planet carrier 32.010 into transmission housing.

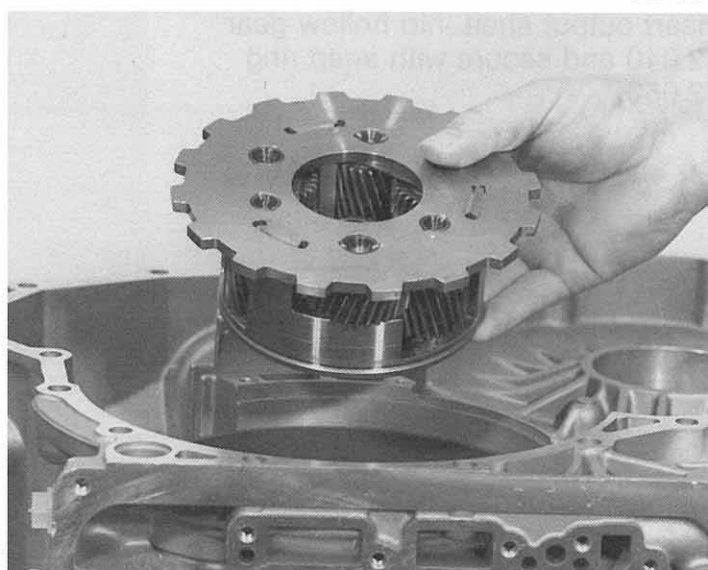

85 252

Install sun gear 32.030 into the planet spider.

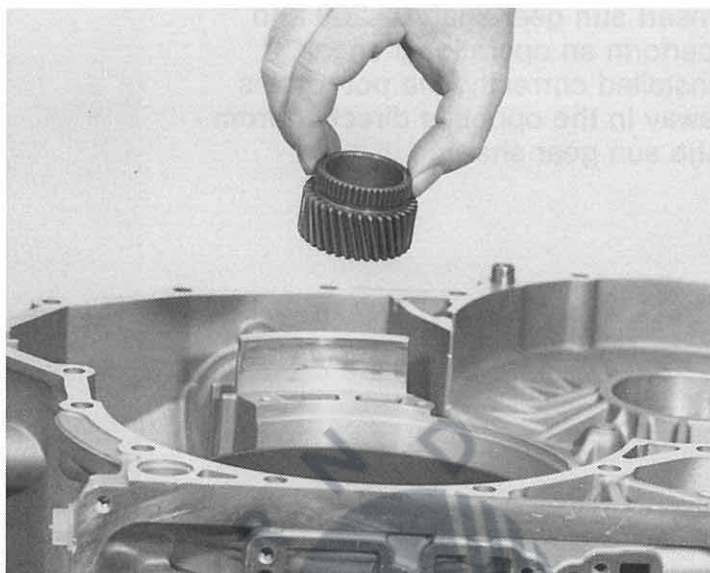

85 253

Fit pot 31.290 onto the teeth of the sun gear.

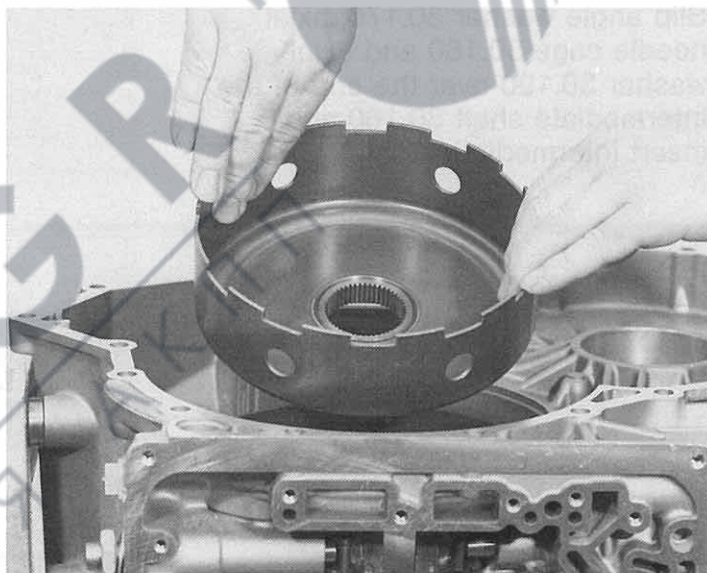

85 254

Insert axial washer 02.230, axial needle bearing 02.220 and angle washer 02.210 into the pot.

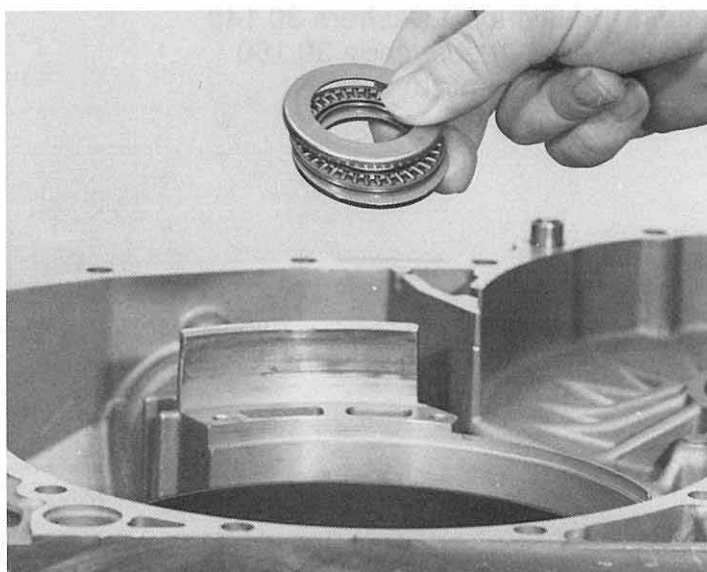

85 255

Insert sun gear shaft 02.200 and perform an operational check. If installed correctly, the pot rotates away in the opposite direction from the sun gear shaft.

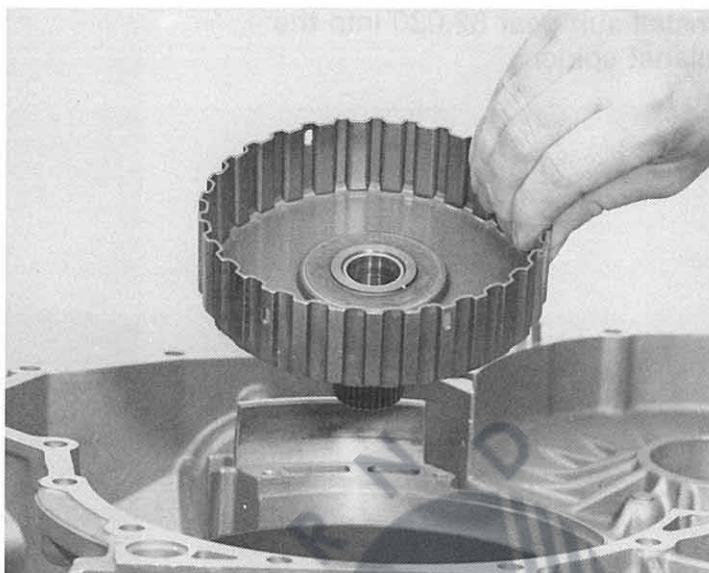

85 256

Slip angle washer 30.170, axial needle cage 30.180 and axial washer 30.190 over the end of the intermediate shaft 30.160 and insert intermediate shaft.

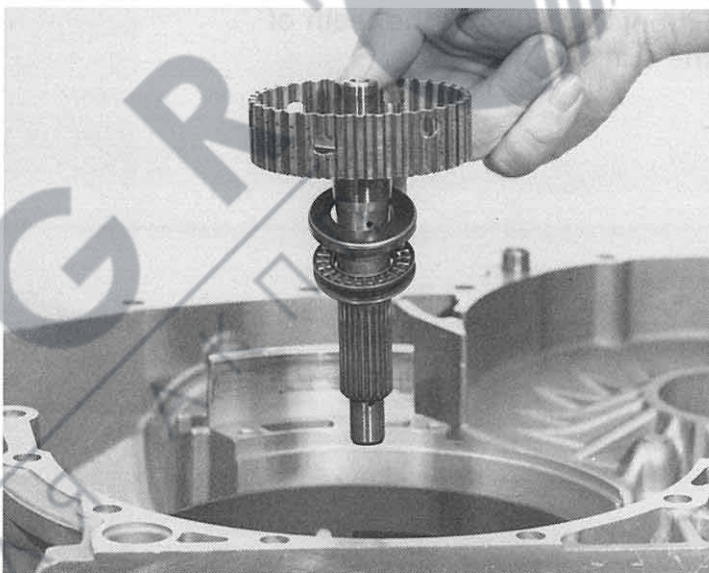

85 257

Insert the two axial washers 30.140 and the axial needle cage 30.150 over the journal of the intermediate shaft.

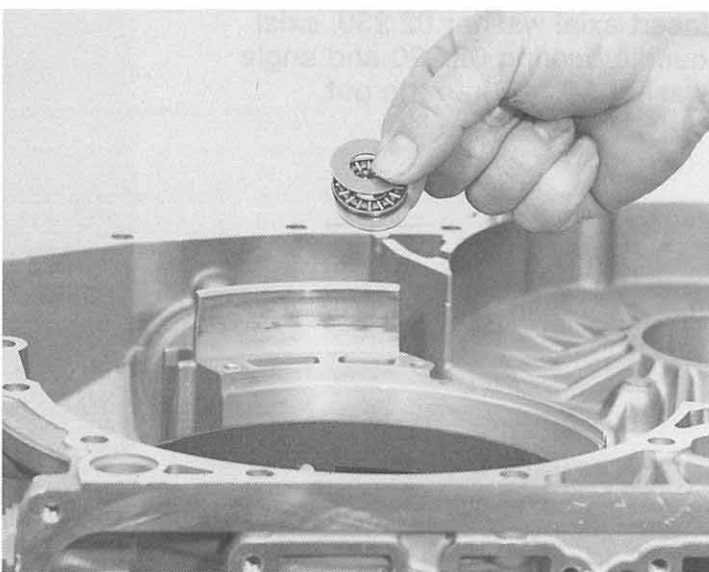

3.5 Engine shaft with clutch E

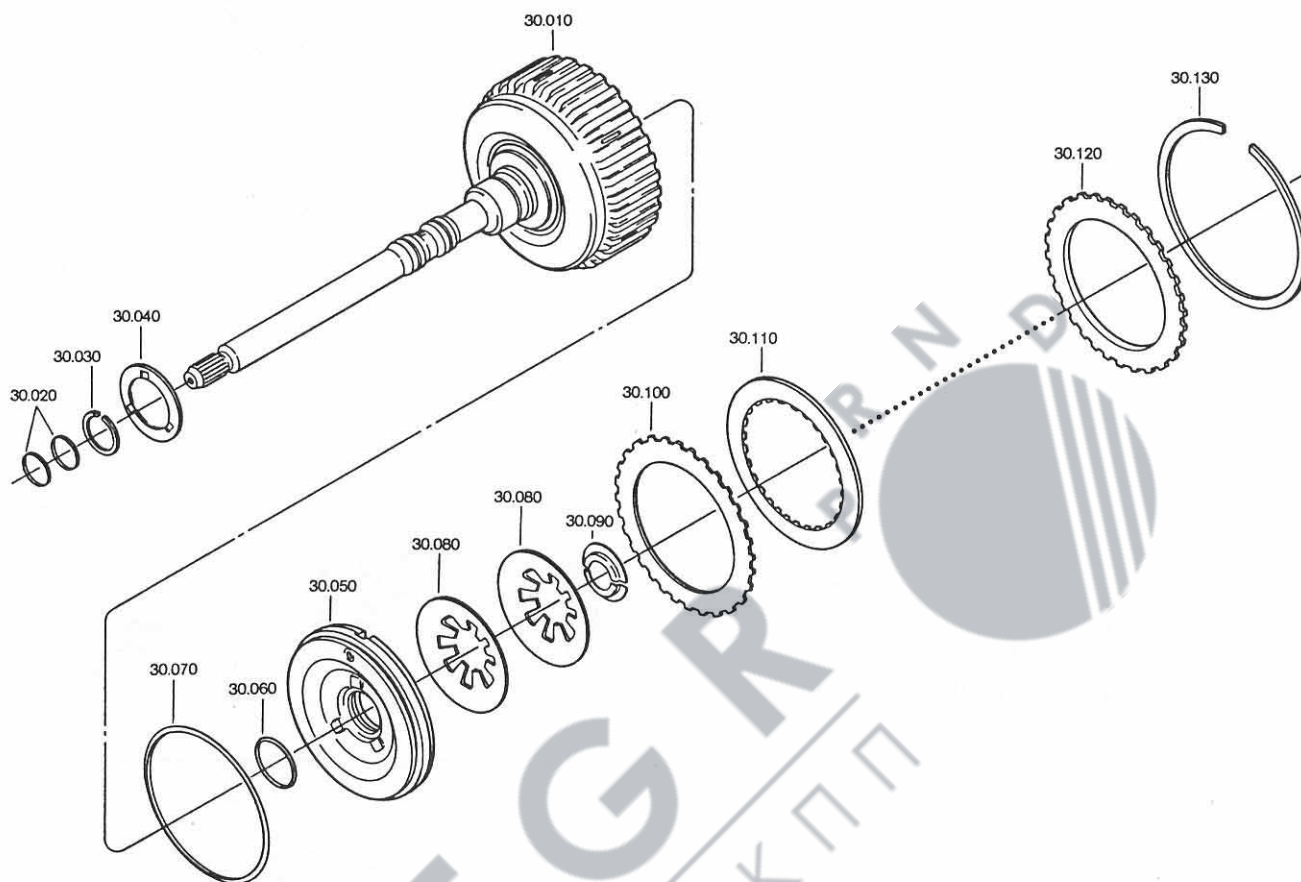

Install new O rings 30.060 and 30.070 onto the piston E 30.050 and apply a light coating of grease (Vaseline).

85 258

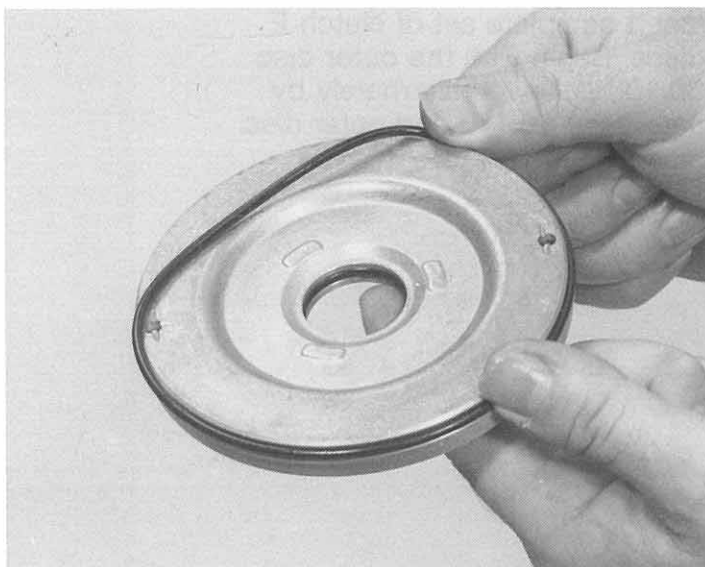

Press piston E into the cylinder of the engine shaft cpl. 30.010.

85 259

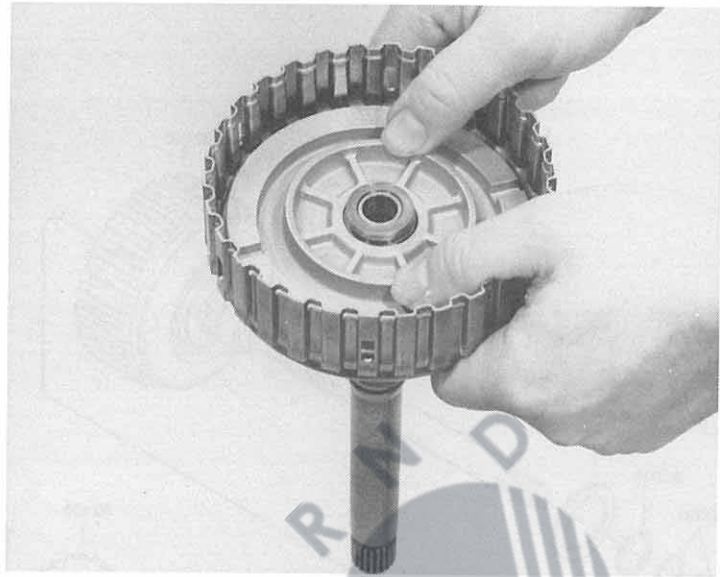

Place the two plate springs 30.080 onto the piston, press down under the mandrel press using mounting device 5 X 46 000 148 and secure with the split retaining ring 30.090.

85 260

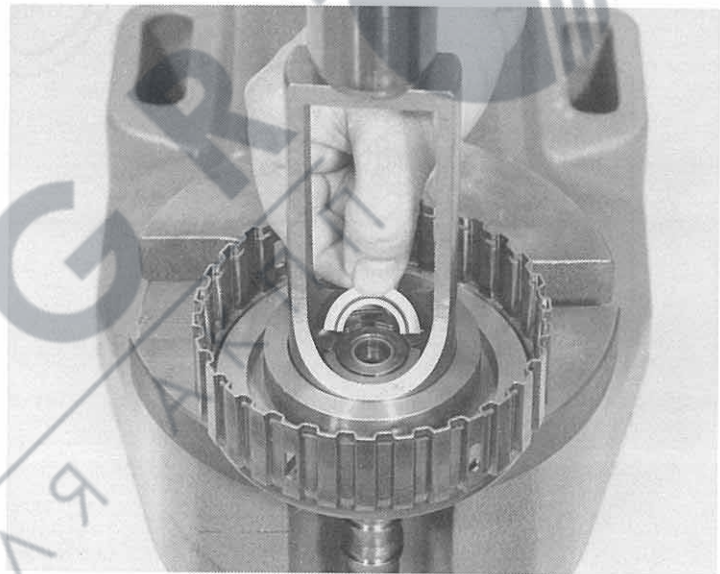

Insert complete set of clutch E discs. Begin with the outer disc 30.100, followed alternately by lined disc 30.110 and outer disc.

85 261

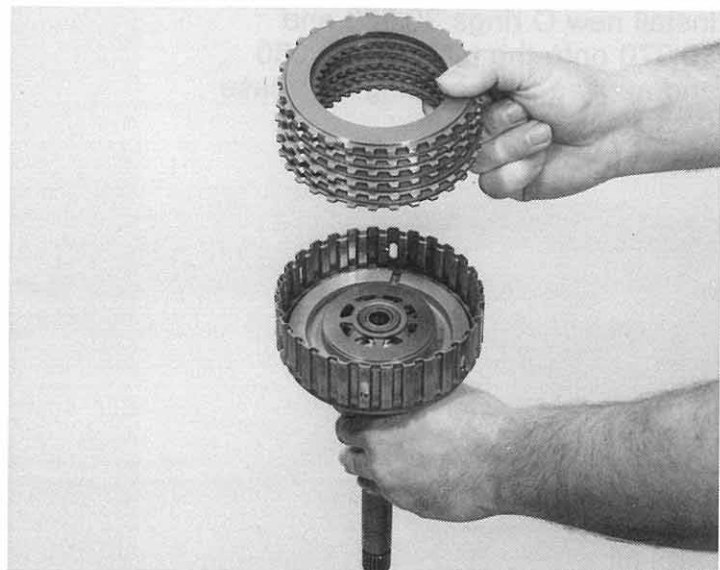

85 262

Place end disc 30.120 onto the last lined disc. The end disc of the version with 5 pairs of discs is installed with the recess to the outside. Secure set of discs with snap ring 30.130.

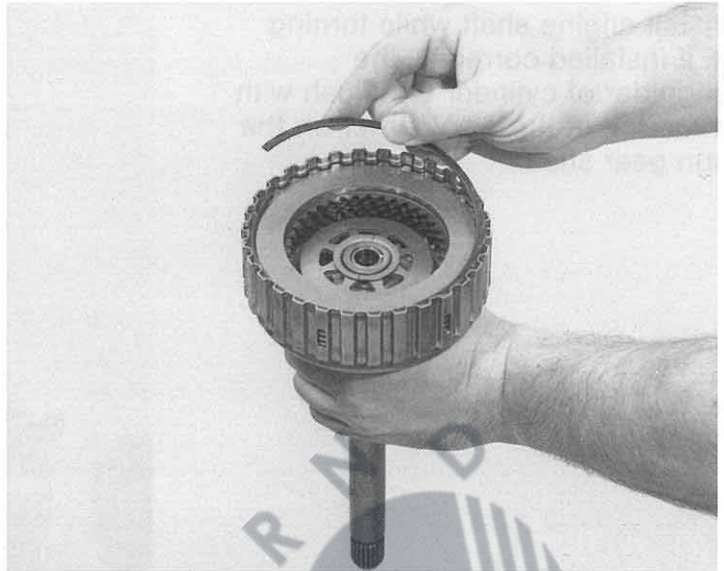

85 263

Fit the two rectangular rings 30.020 and the rectangular ring 30.030 onto the engine shaft and engage hook – coat with Vaseline.

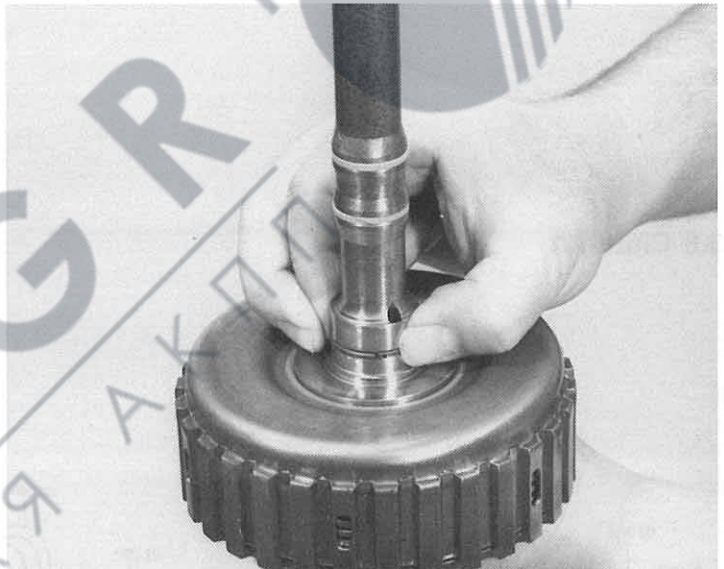

85 264

Fit on thrust washer 30.040 and centre.

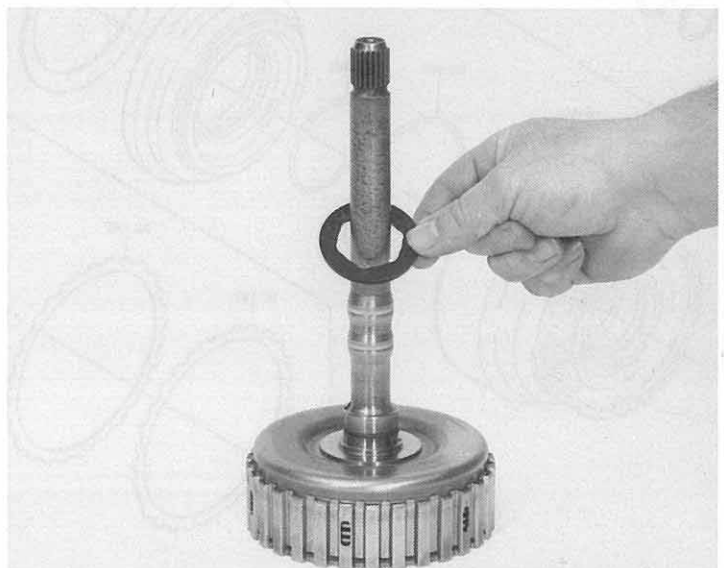

Install engine shaft while turning it. If installed correctly, the shoulder of cylinder E is flush with the edge of the disc carrier on the sun gear shaft.

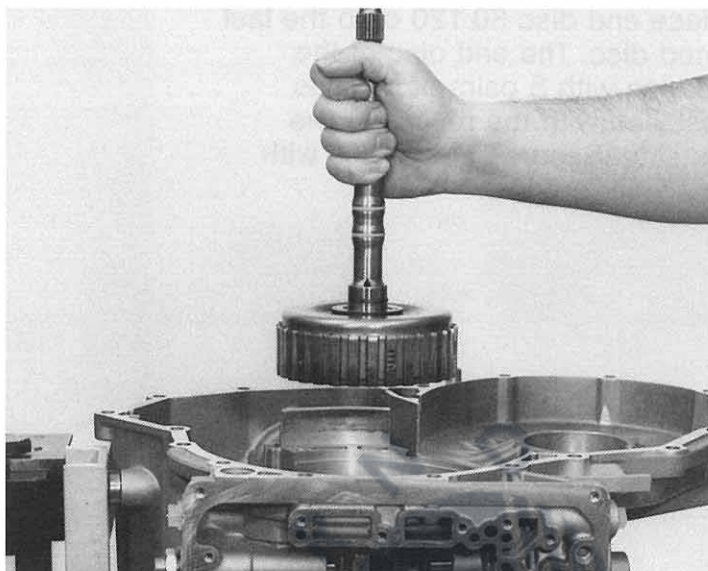

3.6 Clutch A

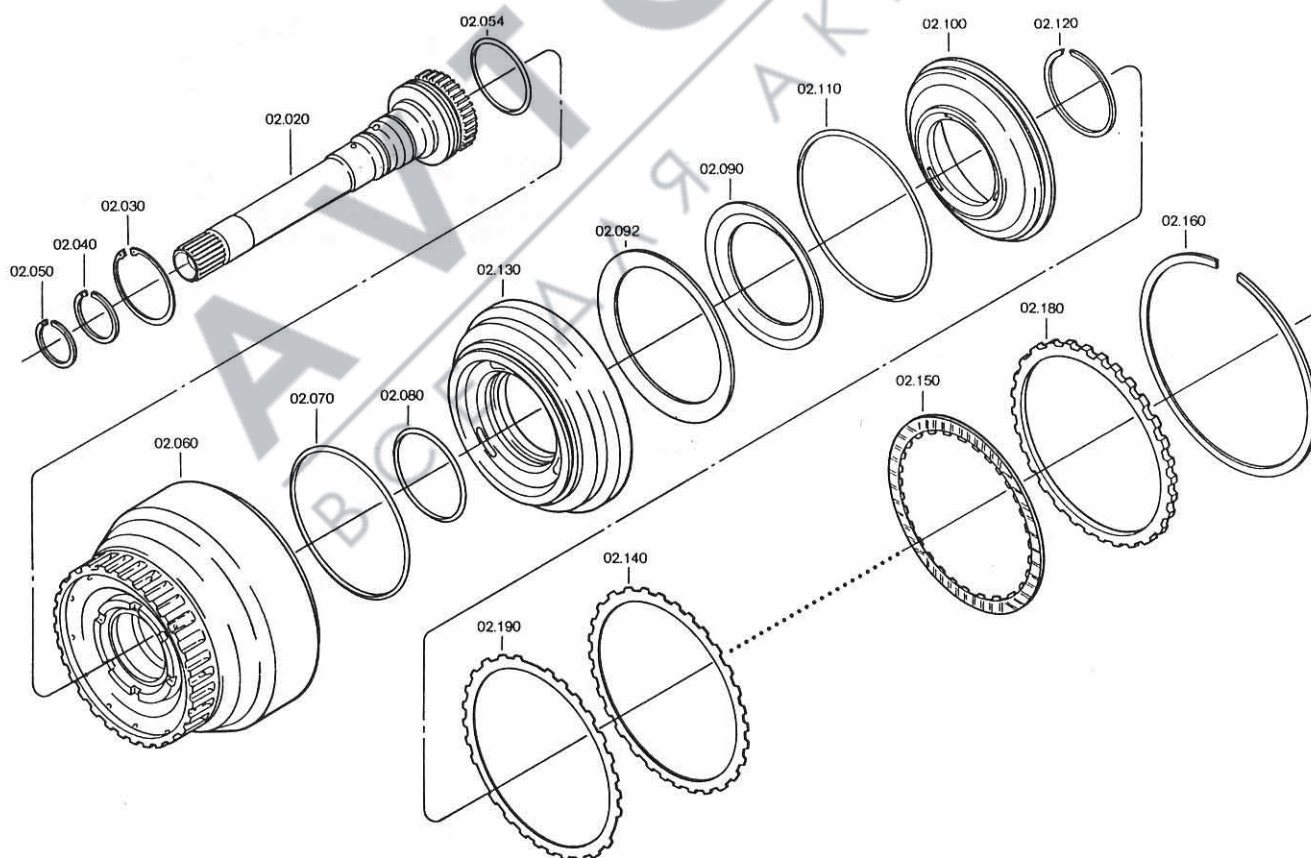

85 196

Fit new O rings 02.070 and 02.080 onto the piston 02.130 and apply a light coating of grease (Vaseline).



85 266

Press piston A into the cylinder A 02.060. First of all insert plate spring 02.092 and on top of this plate spring 02.090 with the curved face pointing up.

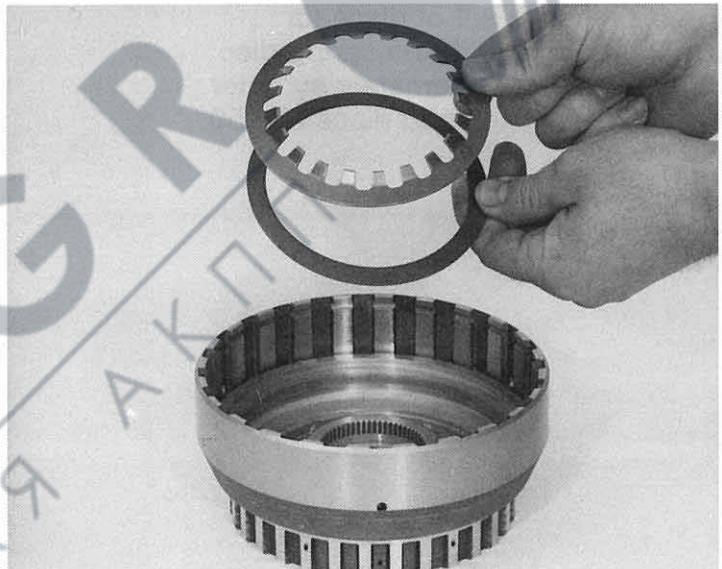

85 267

Fit O ring 02.110 onto the baffle plate 02.100 and apply a light coating of grease (Vaseline).

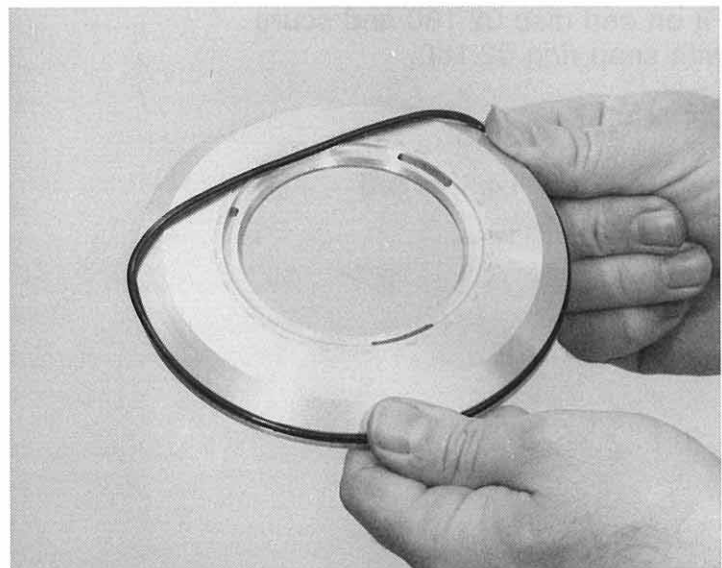

85 268

Insert baffle plate and press down with the legs of special tool 5 X 46 000 167 under the mandrel press. The snap ring 02.120 can be engaged by hand, or suitable pliers used if necessary.

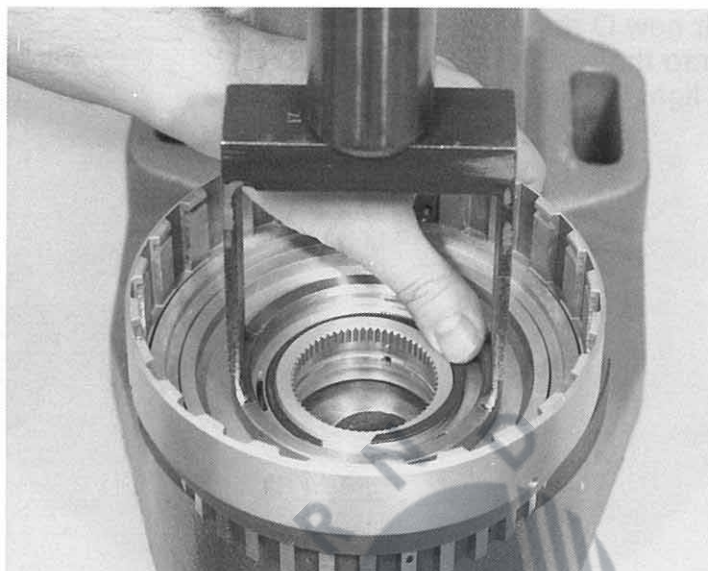

85 269

Insert complete set of discs for clutch A. Begin with the spring disc 02.190, followed alternately by outer discs 02.140 and lined discs 02.150.

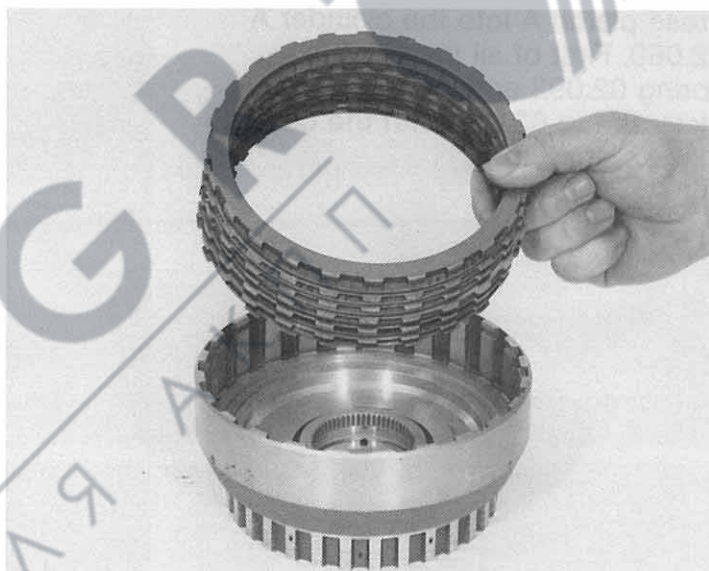

85 270

Fit on end disc 02.180 and secure with snap ring 02.160.

Important!

Adjustment

Refer to Point 1.4.3, p. 5/3

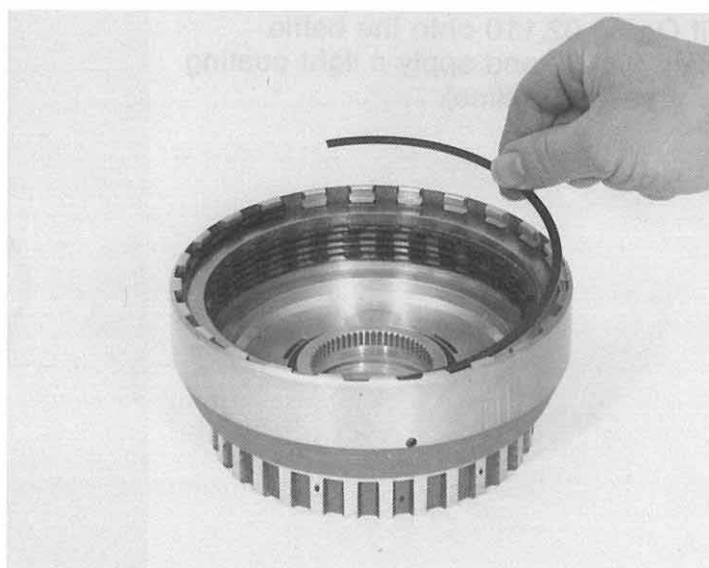

85 274

Fit the two rectangular rings 02.040 and 02.050 onto the turbine shaft 02.020 and engage hook.

Fit on O ring 02.054 and apply a light coating of grease (Vaseline).

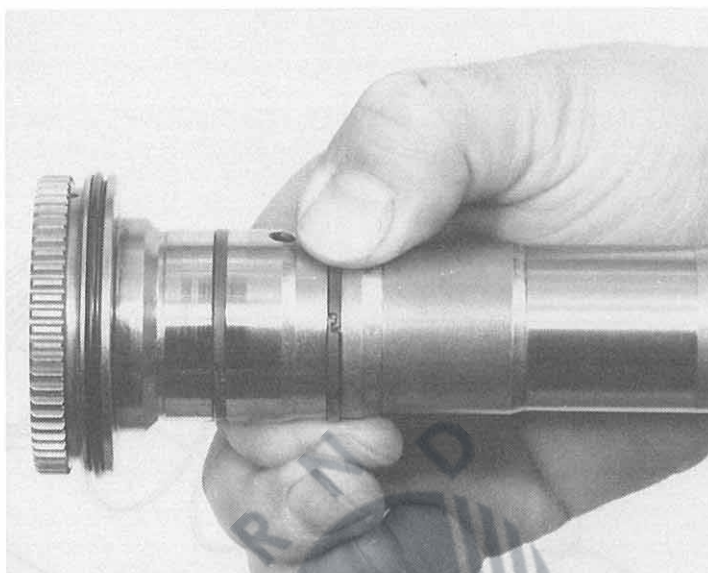

85 275

Press turbine shaft into cylinder A and engage locking ring 02.030 with pliers.

Important!

Pull on turbine shaft until it abuts with snap ring otherwise axial clearance may be falsified.

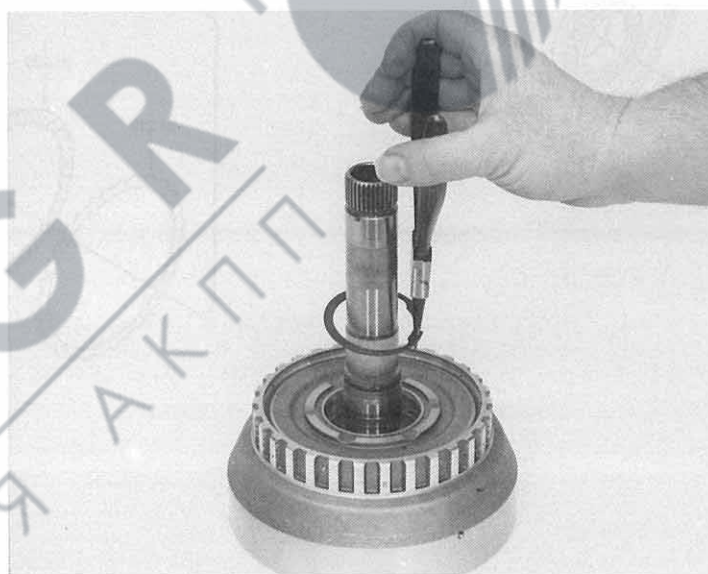

85 276

Insert clutch A complete, turning it back and forward until the teeth of the discs engage.

Important!

Thrust washer (plastic washer) must be centered on the engine shaft. If correctly installed, the engine shaft projects approx. 22 mm over the turbine shaft.

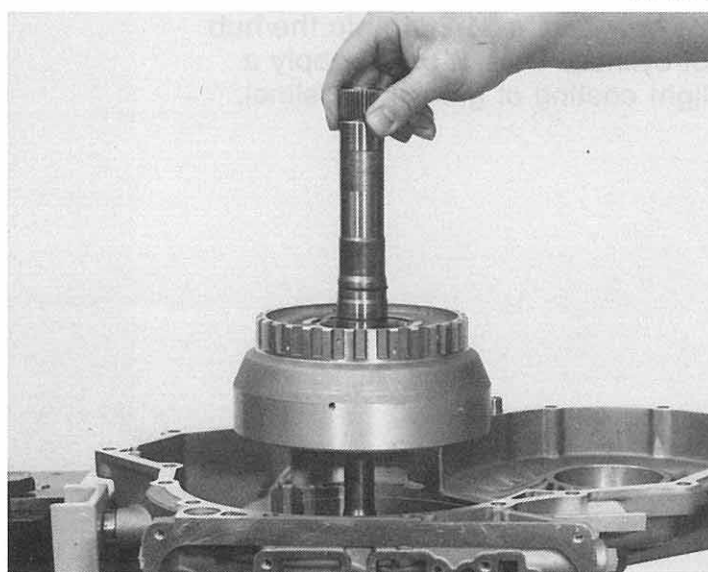

3.7 Clutch B

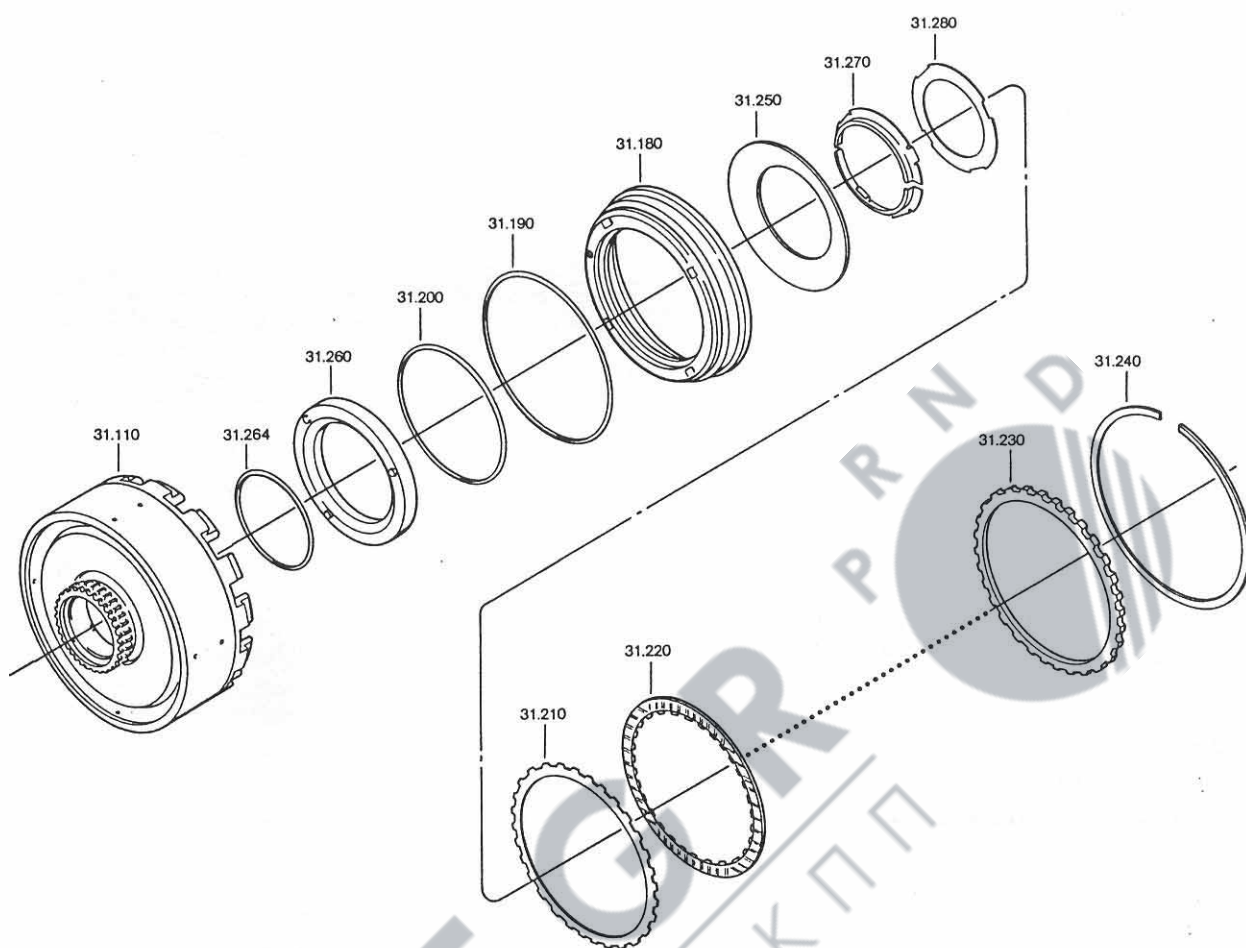

Fit new O ring 31.264 onto the hub of cylinder B 31.110 and apply a light coating of grease (Vaseline).

85277

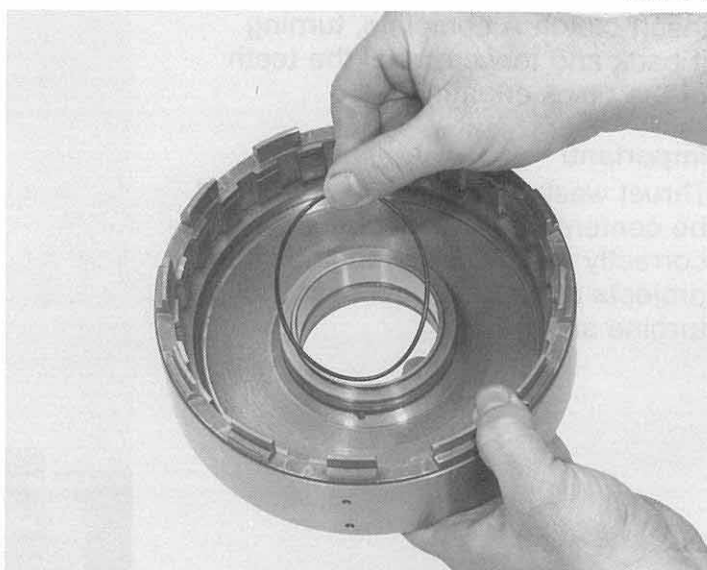

85 278

Press intermediate ring 31.260 with the chamfer facing down into the cylinder until it abuts.

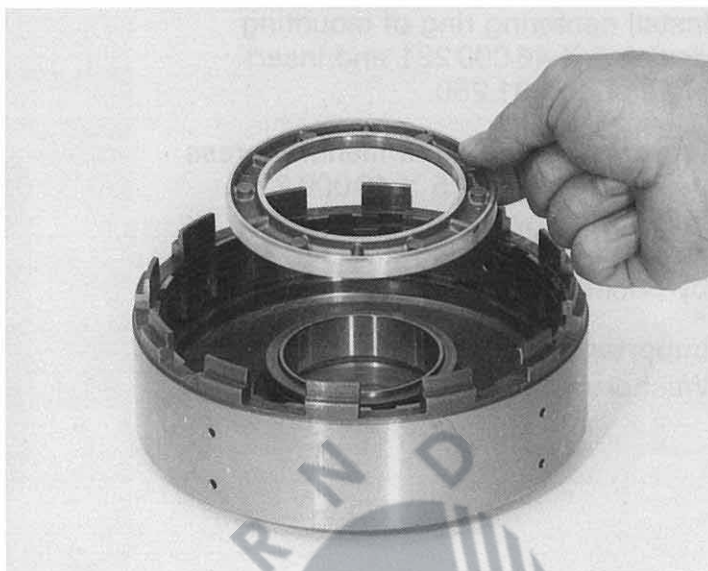

85 279

Fit new O rings 31.190 and 31.200 onto the piston B 31.180 and apply a light coating of grease (Vaseline).

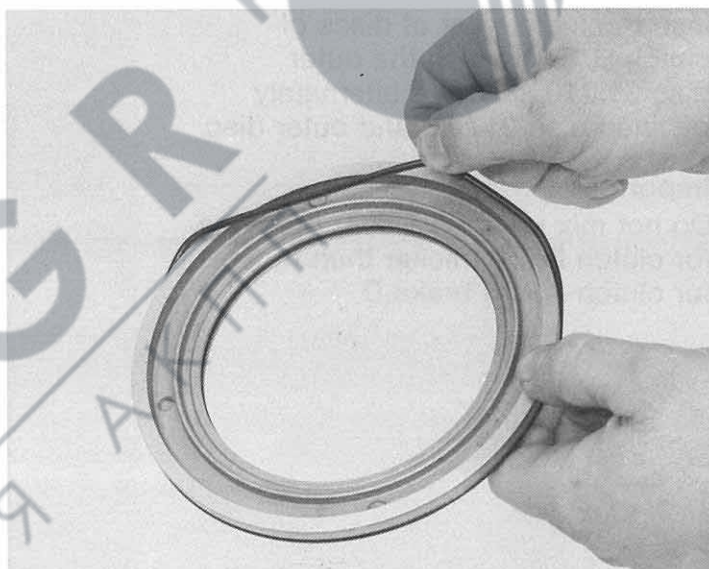

85 280

Press piston into cylinder.

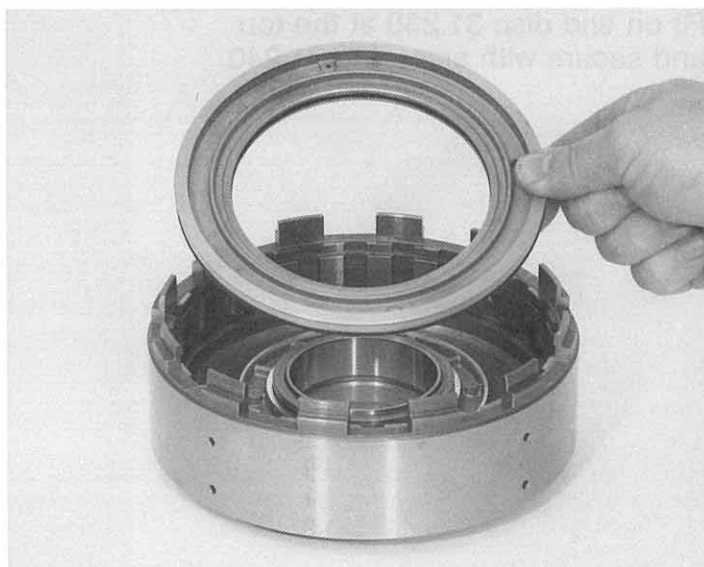

85 281

Install centering ring of mounting device 5 X 46 000 221 and insert plate spring 31.250.

Press down under the mandrel press using special tool 5 X 46 000 221, fit on thrust washer 31.280 and secure with retaining ring 31.270 by pushing the split halves together.

Important!

Washer must rotate freely.

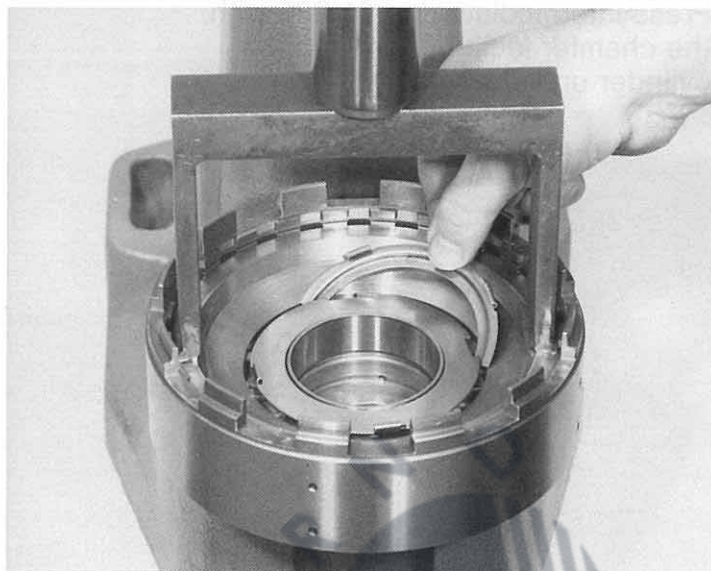

85 282

Insert complete set of discs of clutch B. Begin with the outer disc 31.210, followed alternately by lined disc 31.220 and outer disc.

Important!

Do not mix up lined discs. The ones for clutch B are thicker than those for clutch A and brake D.

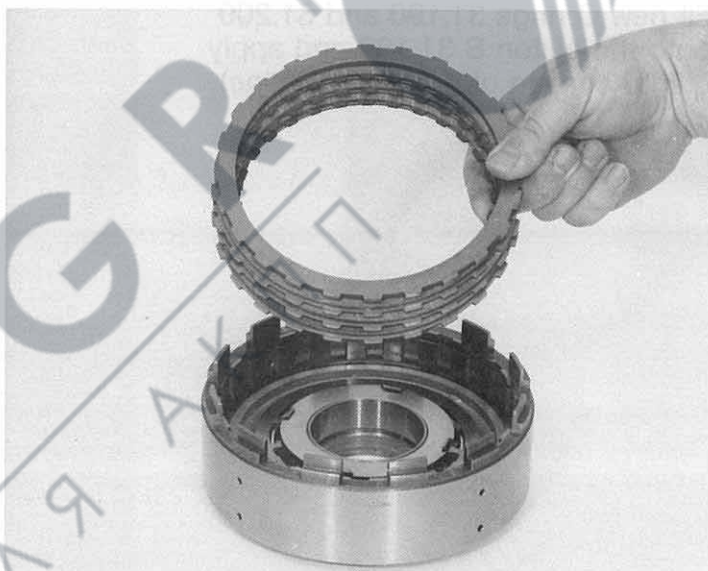

85 283

Fit on end disc 31.230 at the top and secure with snap ring 31.240.



Insert complete clutch B, turning back and forward for as long as is necessary for the discs to fully engage.

If installed correctly, cylinder B must engage in the recesses of the pot far enough for a gap of approx. 1 mm to be still visible.

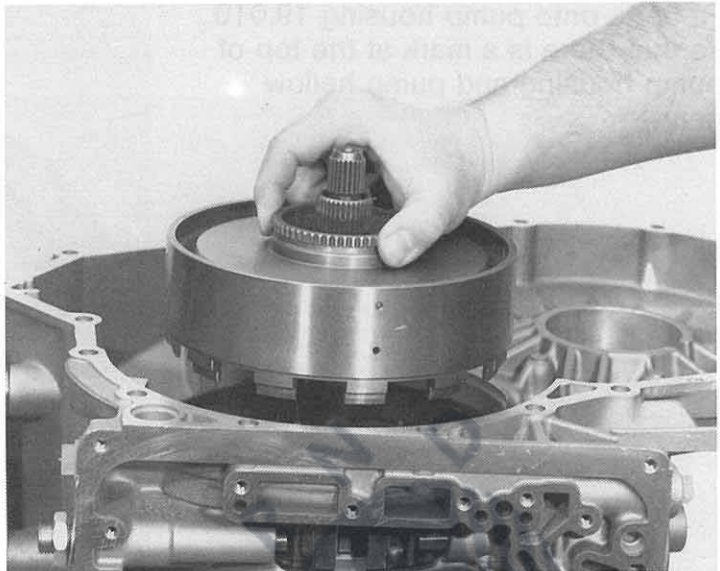

**3.8 Intermediate plate with pump and brake C,
2nd gear freewheel**

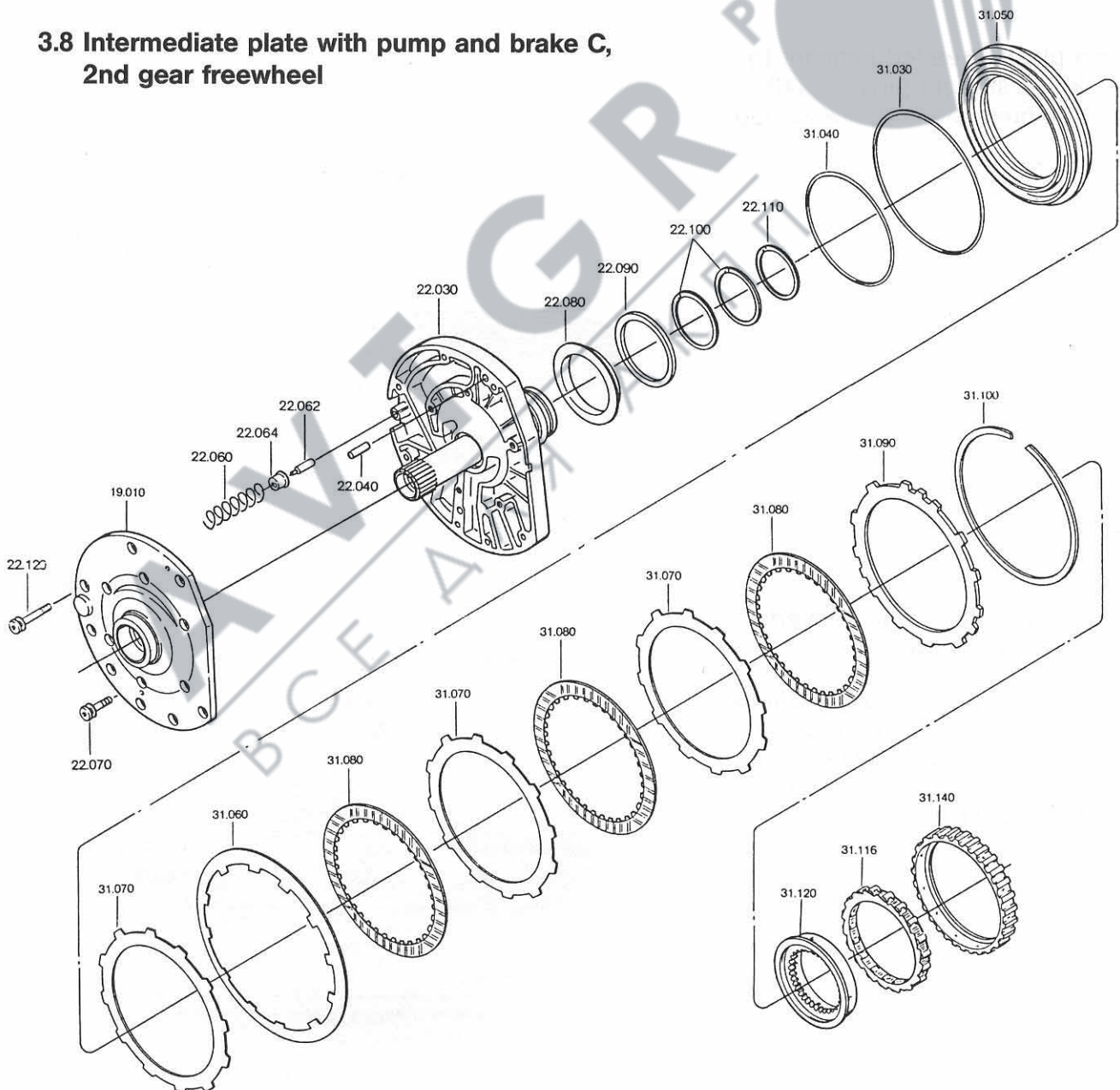

85 285

Fit parts onto pump housing 19.010 so that there is a mark at the top of pump housing and pump hollow gear.

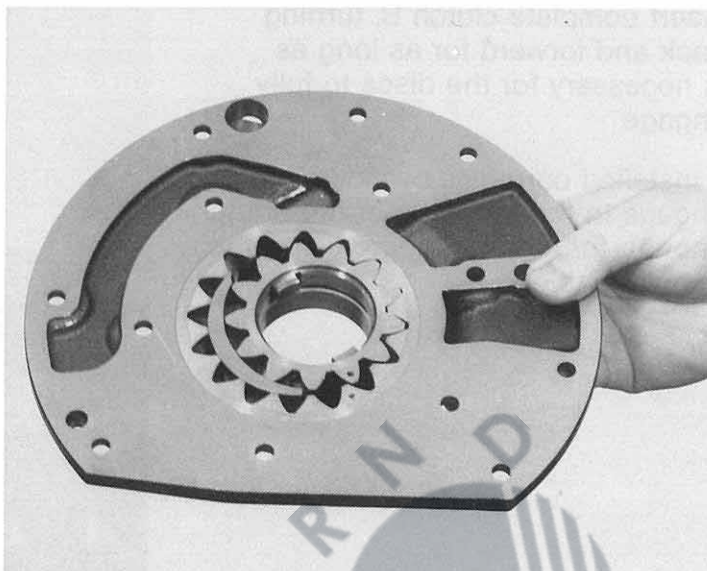

85 286

Use a plastic-headed hammer to knock two straight pins 22.040 into the intermediate plate 22.030.

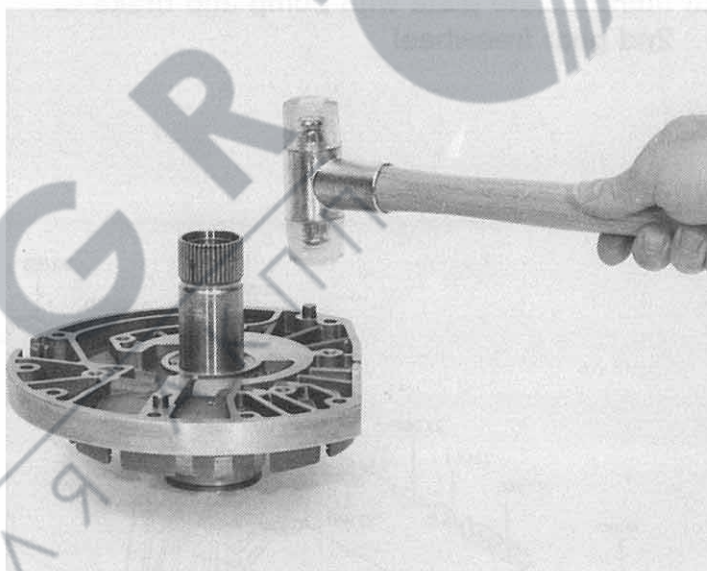

85 287

Install complete torque converter pressure relief valve.

First of all insert valve 22.062 into the cap 22.064 and fit complete onto the intermediate plate. Use grease (Vaseline) to stick it in place, if necessary.

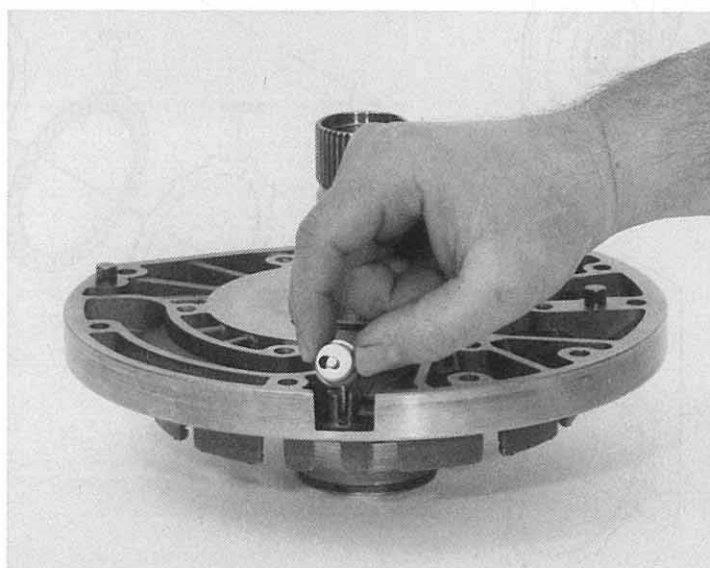

85 288

Insert compression spring 22.060 into the recess of the pump.

Mount intermediate plate onto the pump housing and align.

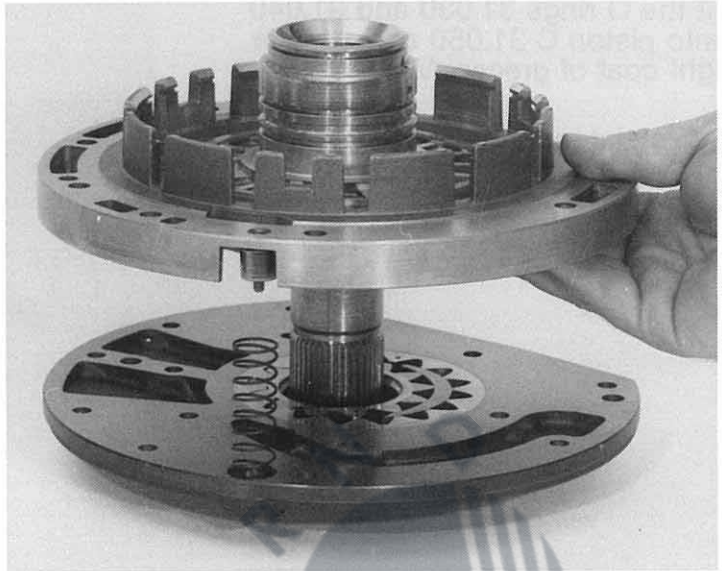

85 289

Press intermediate plate and pump housing onto each other, turn over complete and secure with 6 cylindrical bolts 22.070.

(Width across flats
= Torx socket – TX 27)
(Tightening torque = 10 Nm)

Check that torque converter relief valve operates freely.

Check that pump operates freely using tool 5 X 46 000 306.

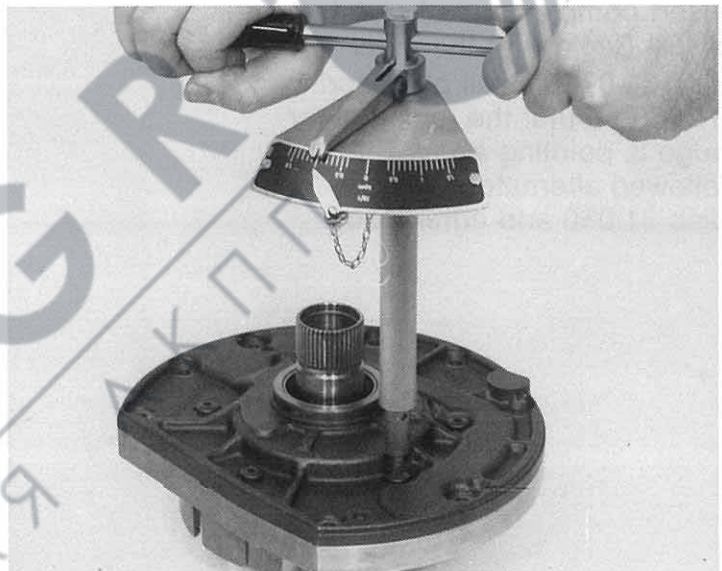

85 290

Install the two rectangular rings 22.100 and rectangular ring 22.110 onto the hub, install intermediate plate and engage hook.

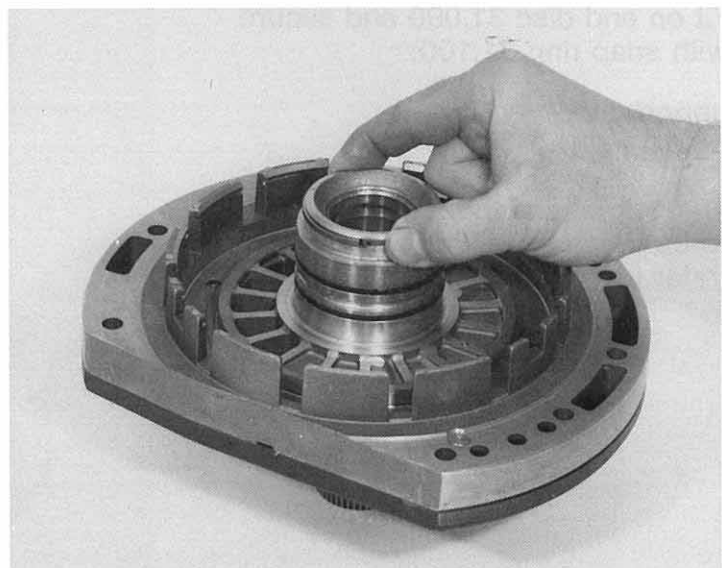

85 291

Fit the O rings 31.030 and 31.040 onto piston C 31.050 and apply a light coat of grease (Vaseline).

Press piston into intermediate plate.

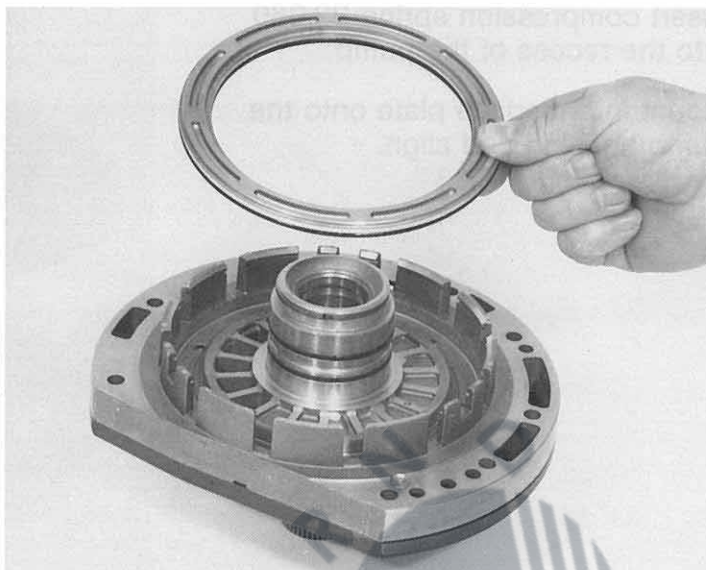

85 292

Insert complete set of clutch C discs. Begin with the outer disc 31.070. Install plate spring 31.060 so that the raised outer edge is pointing away. This is followed alternately by lined disc 31.080 and outer disc.

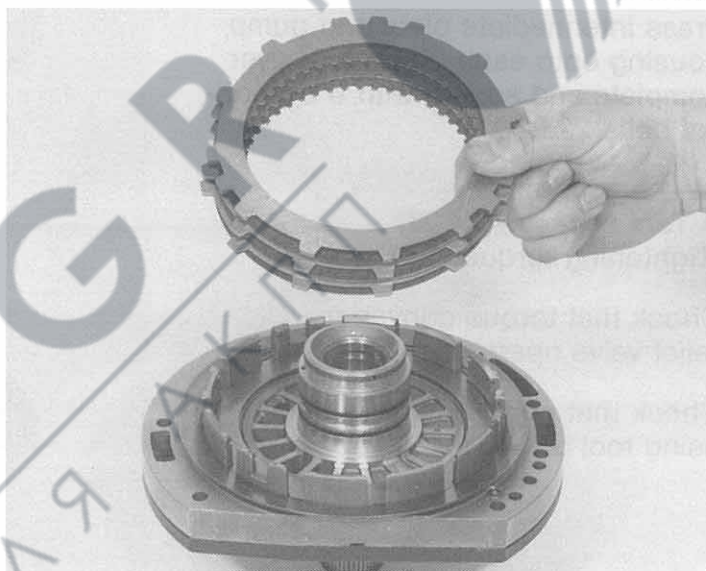

85 293

Fit on end disc 31.090 and secure with snap ring 31.100.

Important!
Adjustment

The thickness of the snap ring has to be determined (refer to Point 1.4.4, p. 5/4).

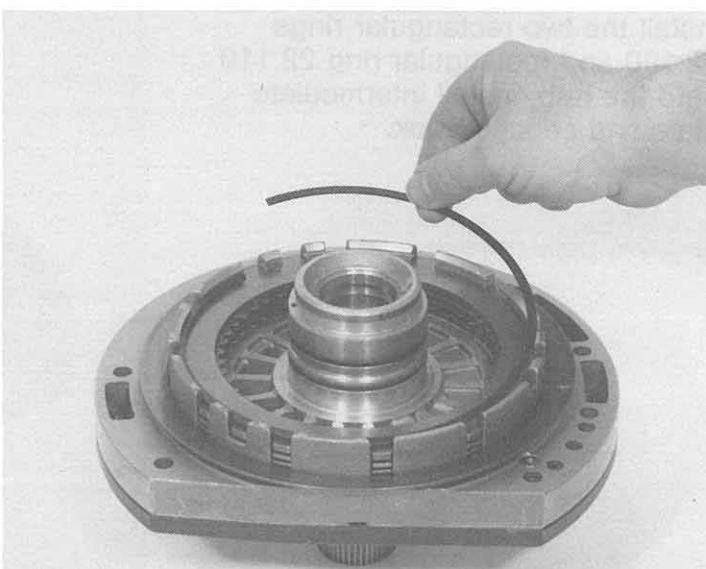

85 297

Complete parts of 2nd gear freewheel by at first pressing one of the two cover discs of freewheel 31.116 into the freewheel outer ring 31.140.



85 298

Insert freewheel cage of freewheel 31.116 with the collar facing down.

Important!

If not installed properly (wrong way round), the clamping direction will not be correct.



85 299

Fit on cover disc of freewheel 31.116 and press it in.

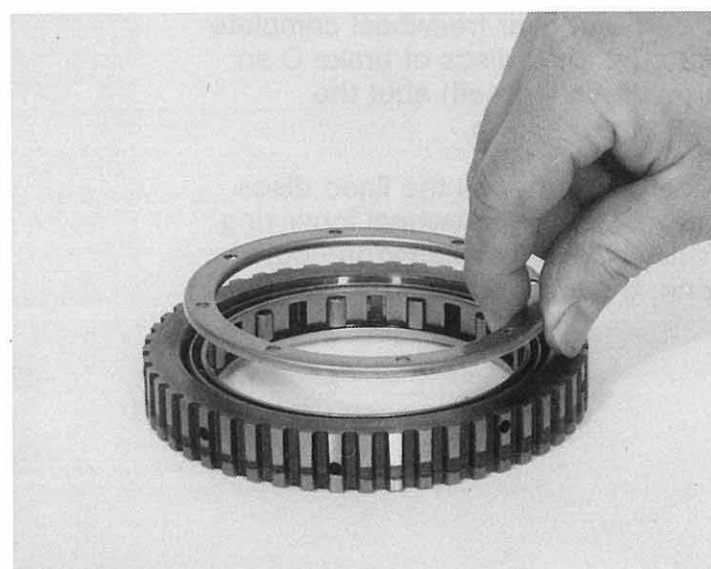

85 300

Insert freewheel inner ring 31.120 from the front, turning it clockwise.

Important!

Operational check:

Freewheel inner ring must rotate freely in the clockwise direction with the collar pointing away or with the inner teeth when the outer ring is held tight.



85 307

Before the adjusting washer 22.090 is installed, the thickness of the washer has to be determined.

Important!

Adjustment
(refer to Point 1.4.5, p. 5/5).

Install angle washer 22.080 and calculated size of adjusting washer 22.090 onto the hub of intermediate plate.

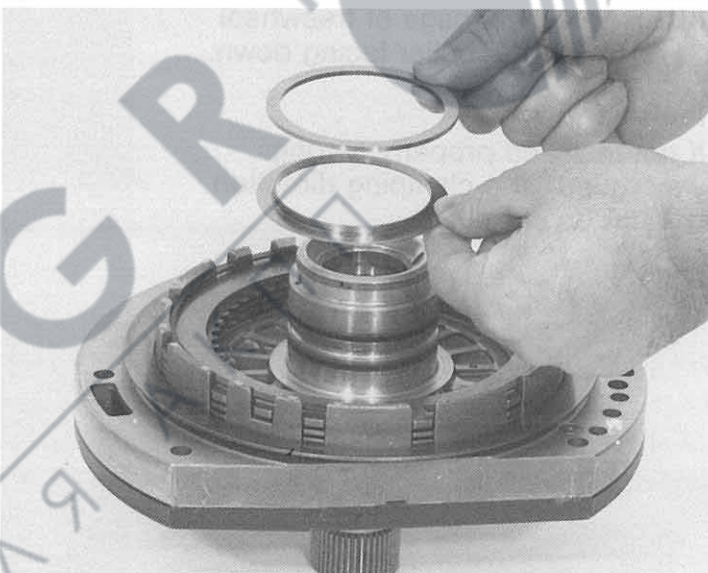

85 306

Insert 2nd gear freewheel complete into the lined discs of brake C so that the inner teeth abut the washers.

Check whether all the lined discs mesh with the freewheel inner ring. This is done by rotating the outer ring; the lined discs must also turn.

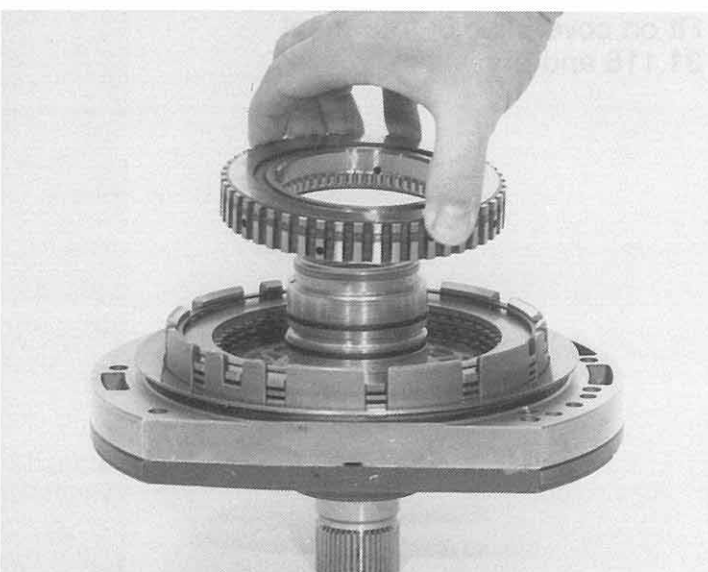

85 308

Slightly tighten the adjusting washer of brake band in order to fix cylinder B in place. Turn transmission through 90°.

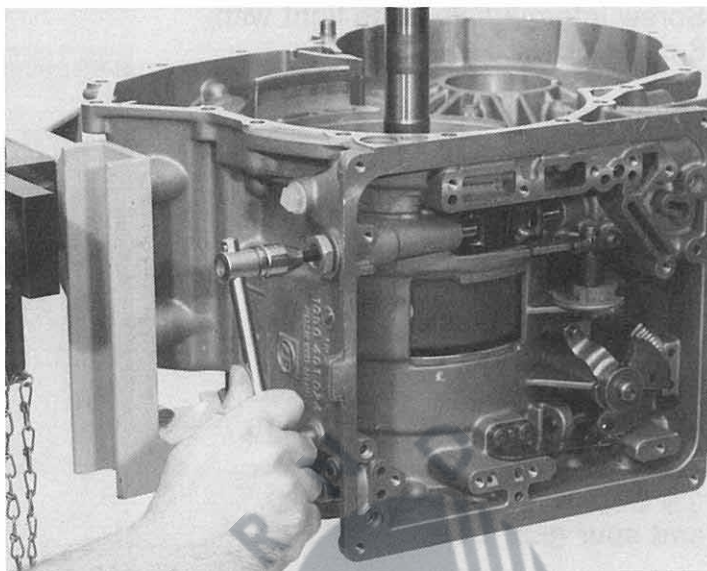

85 309

Insert the complete unit (pump, intermediate plate and 2nd gear freewheel) into the transmission housing, while rotating it back and forth.

Important!

When inserting, hold freewheel in place to avoid slippage out of the set of discs.

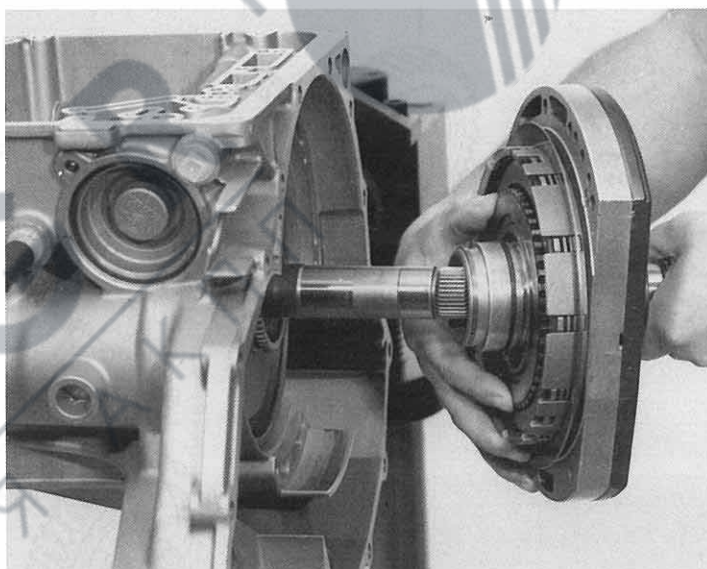

85 310

If installed correctly, the plate springs about the transmission housing and, when pressure is applied, presses against the pump housing.

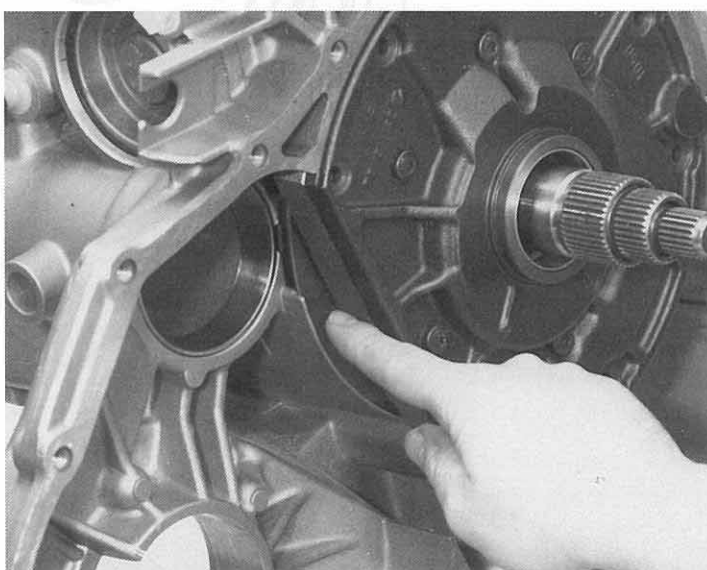

Screw intermediate plate tight with
8 cylindrical bolts 22.120.

(Width across flats
= Torx socket – TX 27)
(Tightening torque = 10 Nm)

Slacken brake band and check axial
clearance.

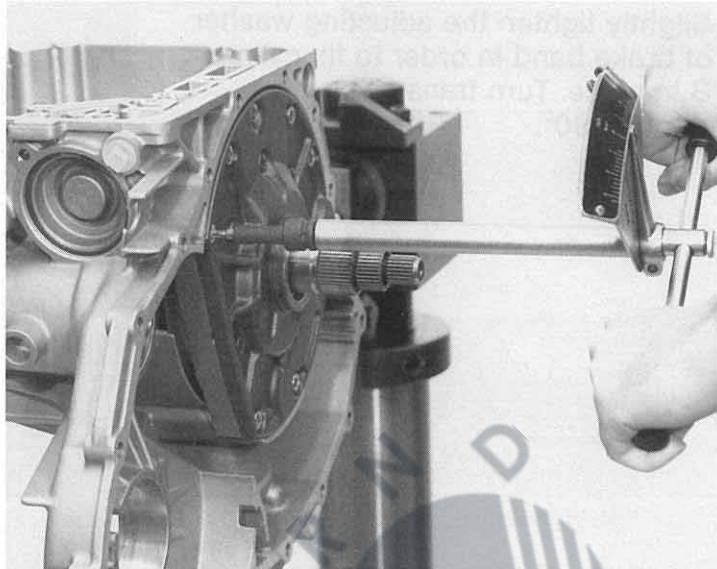

3.9 Governor, counter shaft and spur gear train

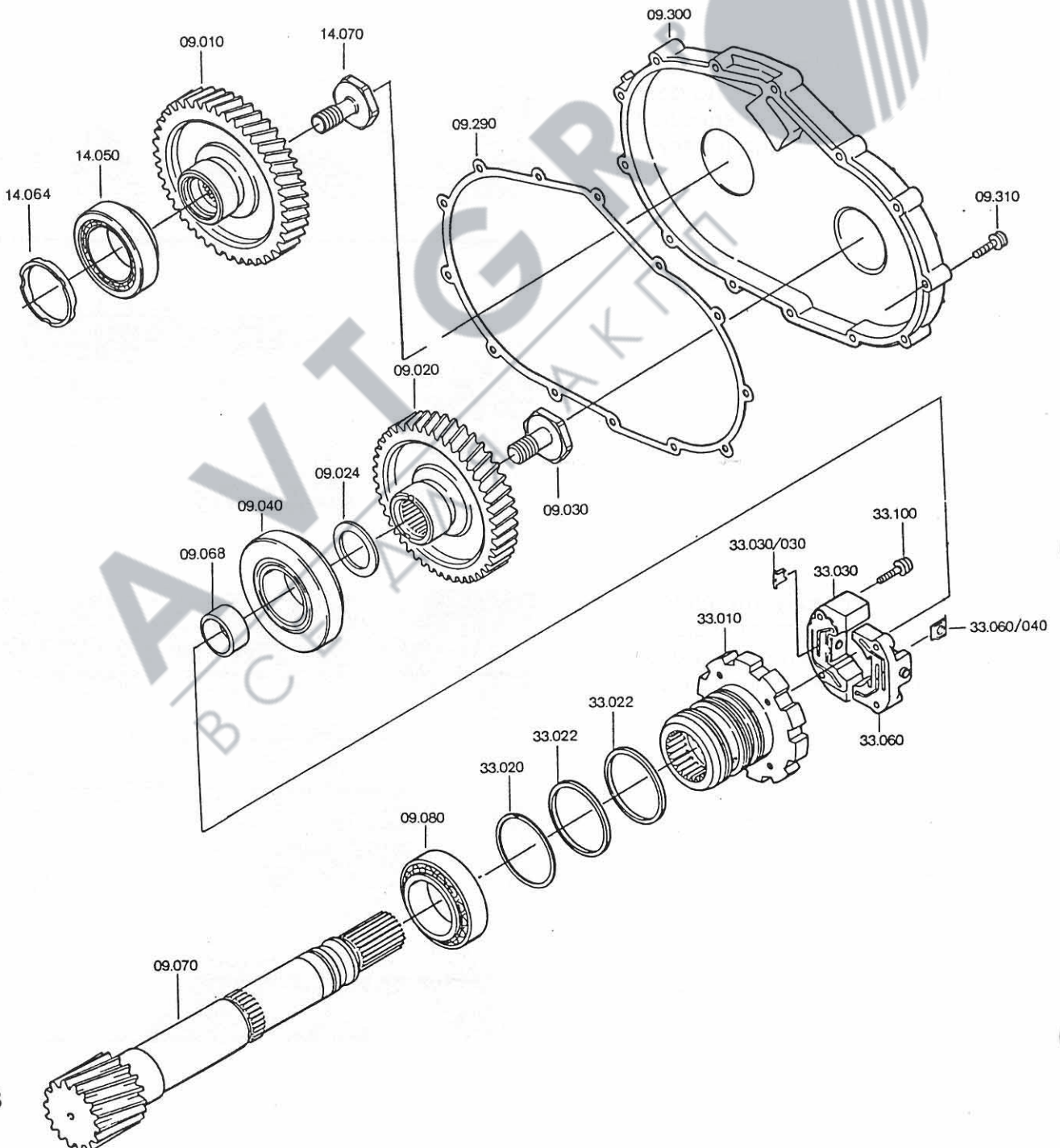

Complete parts of governor housing I 33.030.

This is done by inserting governor piston in housing and securing it with tab washer 33.030/030.

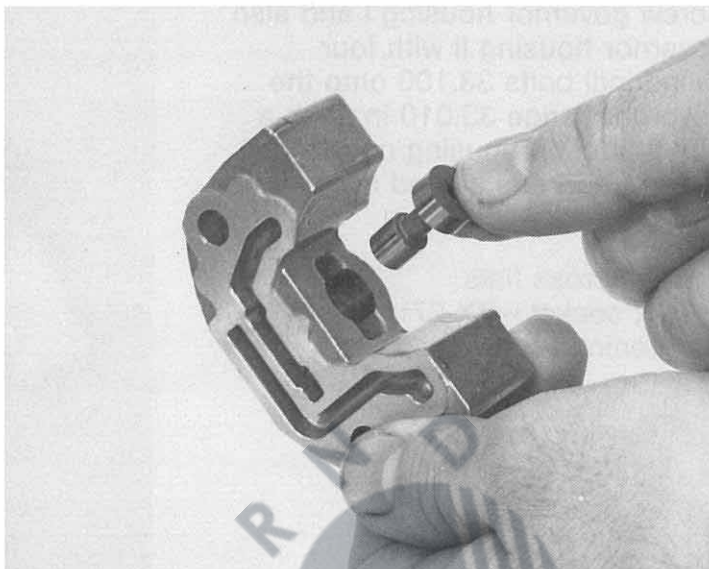

Complete parts of governor housing II 33.060.

This is done by inserting governor piston, fitting the two compression springs into the piston and inserting the retaining plate 33.060/040.



The photo opposite shows the governor when disassembled.

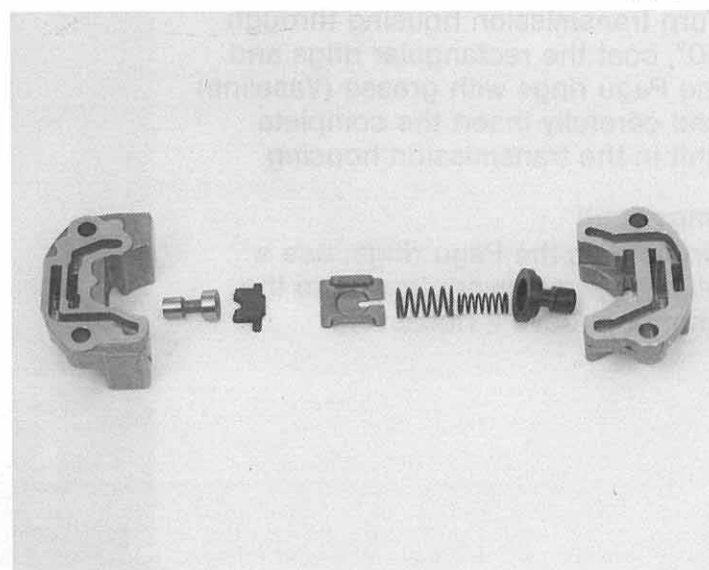

85 313

Screw governor housing I and also governor housing II with four cylindrical bolts 33.100 onto the governor flange 33.010 in such a way that each housing covers one straight and one angled oil feed passage.

(Width across flats
= Torx socket – TX 27)
(Tightening torque = 10 Nm)

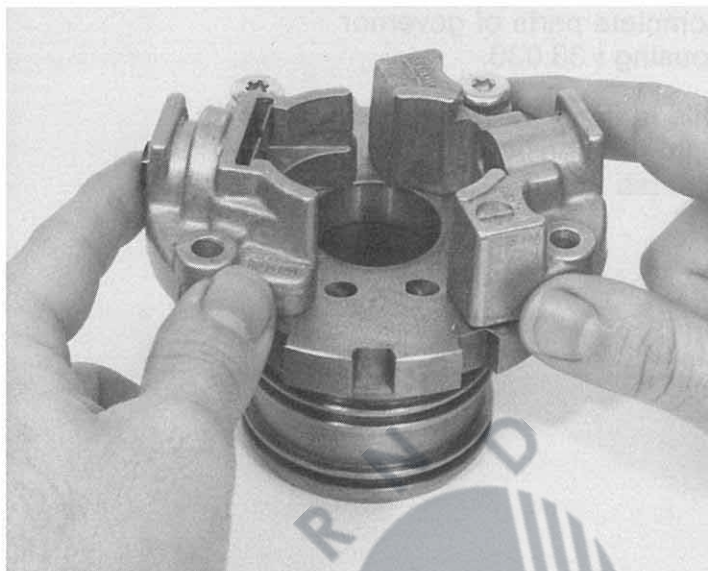

85 314

Fit rectangular ring 33.020 onto the beginning of the governor flange and engage hook, insert 2 Pagu rings 33.022 into the middle and rear annular groove.

Important!

Do not widen the Pagu rings any more than necessary for fitting.

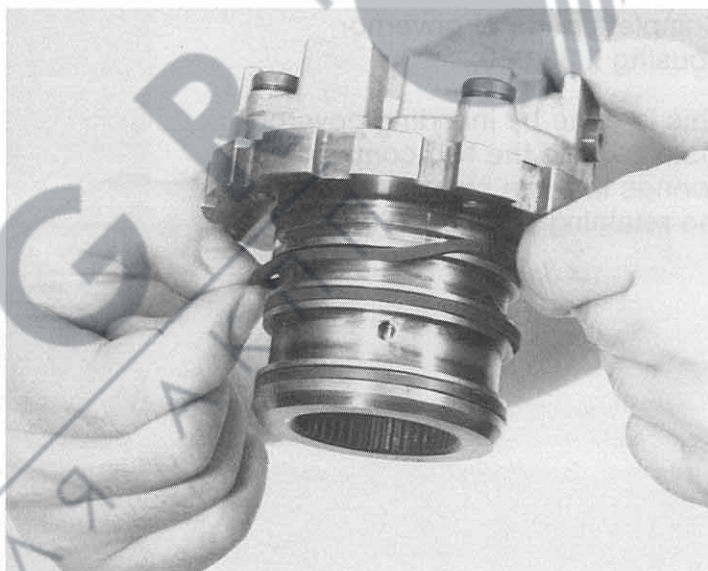

85 315

Turn transmission housing through 90°, coat the rectangular rings and the Pagu rings with grease (Vaseline) and carefully insert the complete unit in the transmission housing.

Important!

Do not jam the Pagu rings; use a blunt object to work them into the annular groove if necessary.

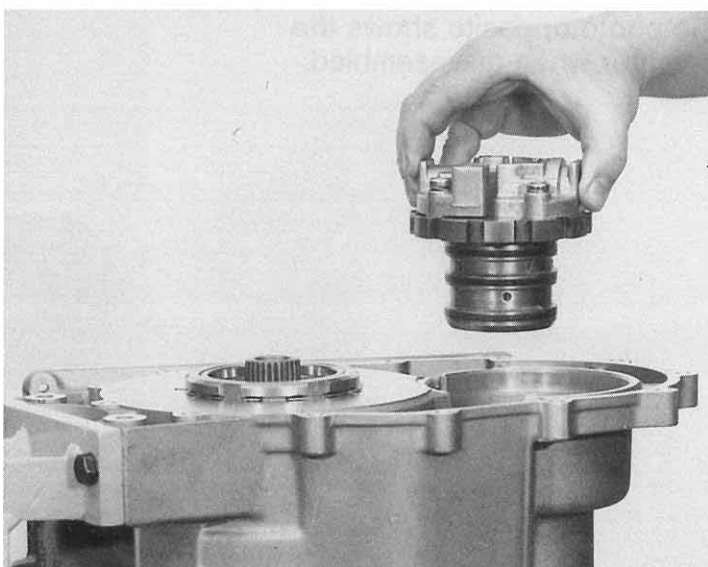

85316

Install the tapered roller bearing inner ring of bearing 09.080 onto the counter shaft 09.070 under the mandrel press using the special aid, ring 5 X 46 000 327.

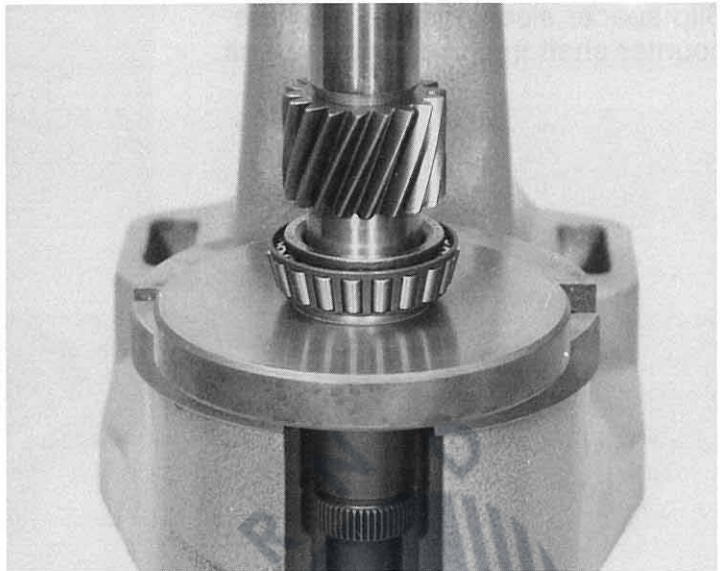

85317

Turn transmission through 90° and insert counter shaft into the engaging gears of the governor flange while rotating the shaft and holding the flange in position to prevent it from falling out.

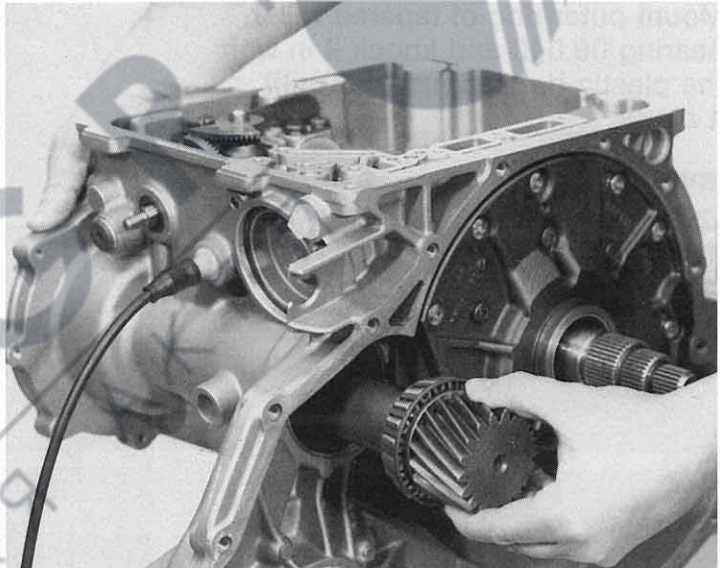

85318

Screw on retaining device 5 P 95 000 300 and turn transmission through 90°.

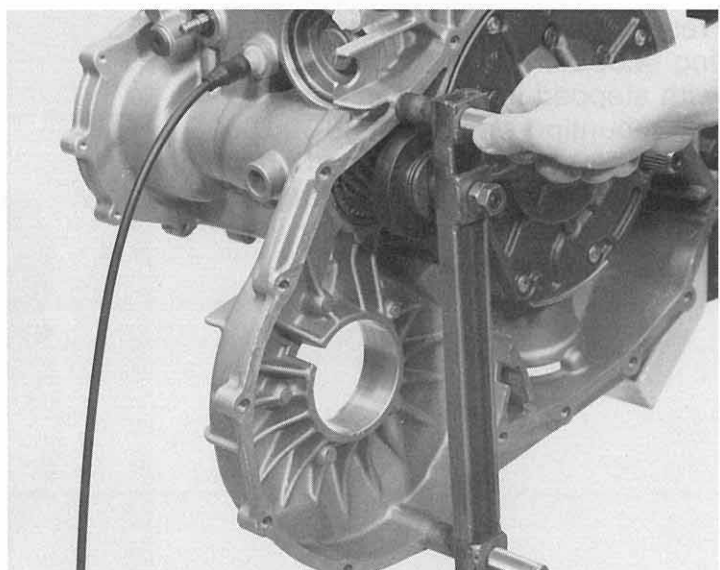

85 319

Slip spacer sleeve 09.069 over the counter shaft into the governor unit.

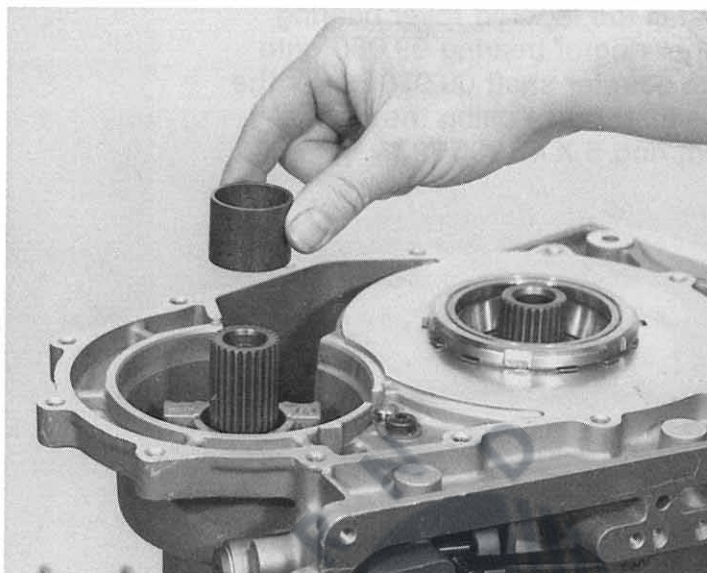

85 320

Mount outer ring of tapered roller bearing 09.040 and knock it in with the plastic-headed hammer until it abuts.

Important!

Outer ring must be installed with no clearance to ensure it is correctly adjusted for measuring.

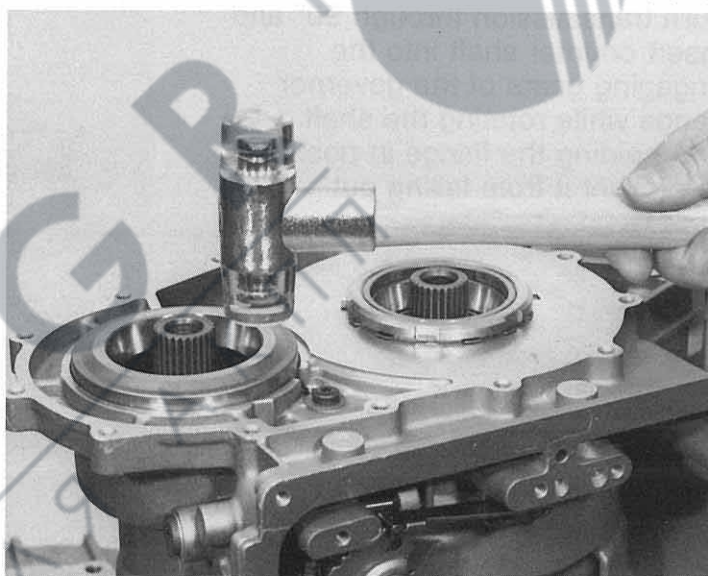

85 321

Press tapered roller bearing inner ring 14.050 onto spur gear 09.010 (with stepped internal gearing) with mounting sleeve 5 X 46 000 300 under the mandrel press, and press tapered roller bearing inner ring 09.040 onto spur gear 09.020 with mounting sleeve 5 X 46 000 174.



85 322

Before installing washer 14.064 onto the tapered roller bearing inner ring of the output shaft, the thickness of the washer has to be determined.

Important!

Adjustment
(refer to Point 1.4.6, p. 5/7).

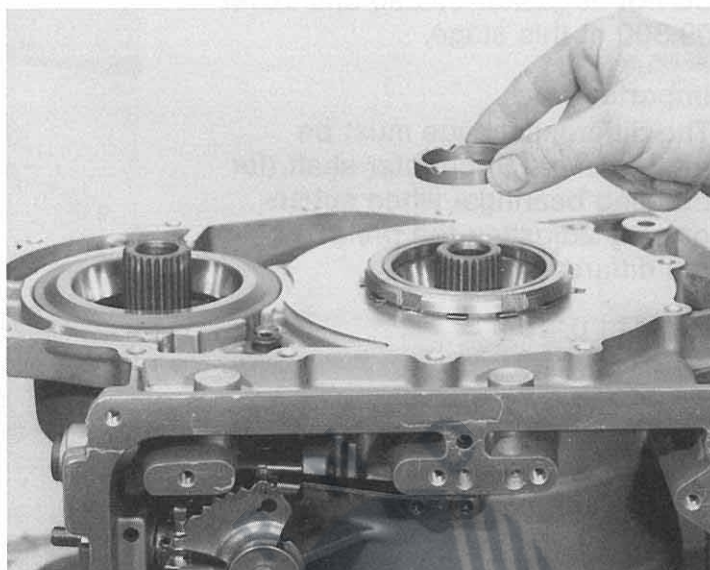

85 323

Insert washer 09.024 and mount spur gear 09.020 onto the counter shaft. Loosely screw in bolt 09.030.

Important!

Adjustment
(refer to Point 1.4.6.2, p. 5/13).

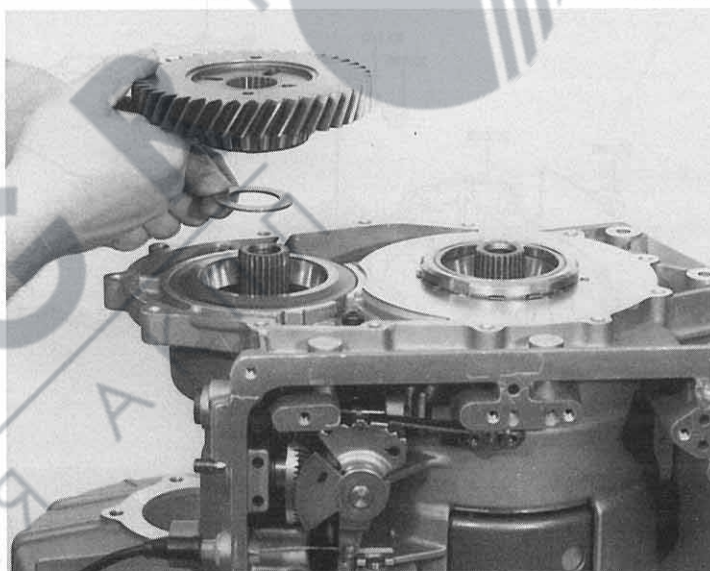

85 331

Fit on spur gear 09.010 and secure with bolt 14.070.

(Width across flats = 36 mm)
(Tightening torque = 150 Nm).

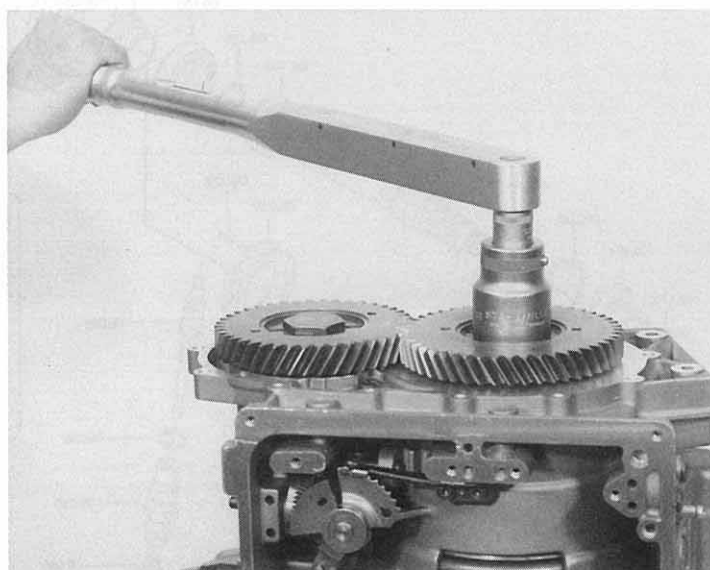

Do **not** fit gasket 09.290 and cover 09.300 at this stage.

Important!

The differential cage must be rotated over the counter shaft (for bedding bearings) when subsequently adjusting the preload of the differential.

Refer to p. 104.

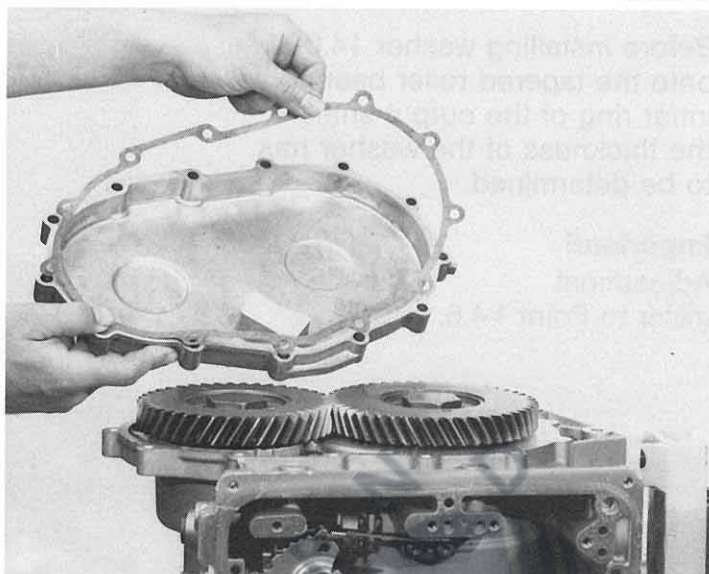

3.10 Differential, input shafts and converter bell housing with speedometer

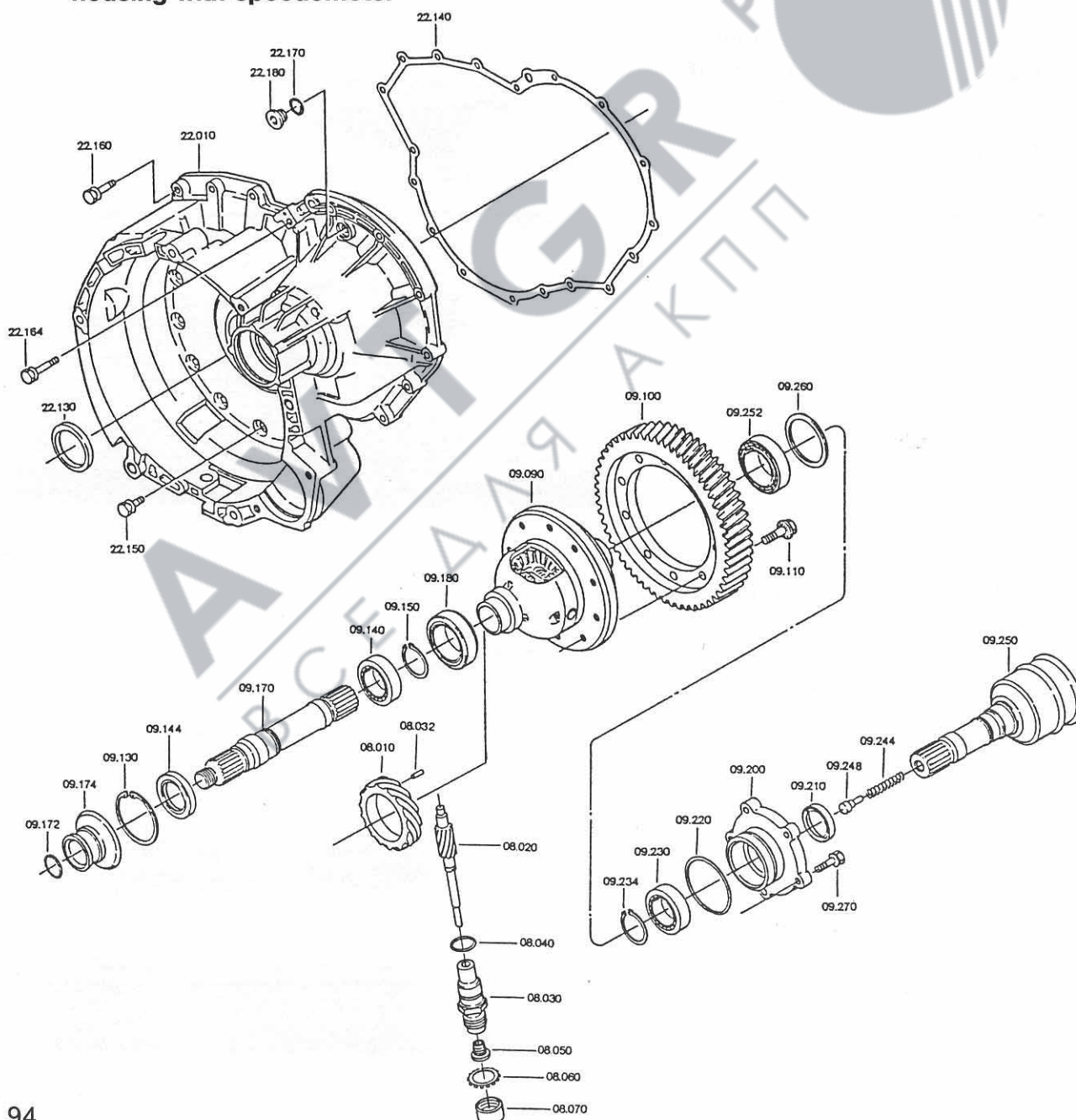

85 350

Insert the two axle bevel gears into the differential cage 09.090 so that the two axle bores are exactly aligned.

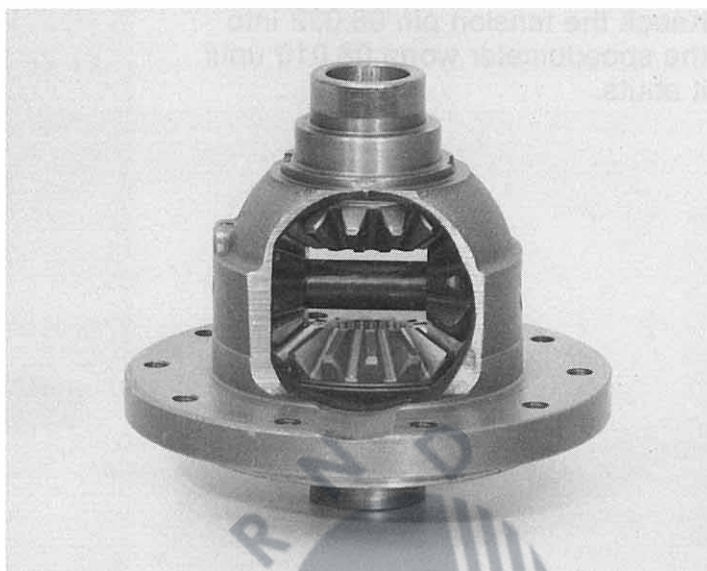

85 348

Turn transmission through 180° and remove the device.

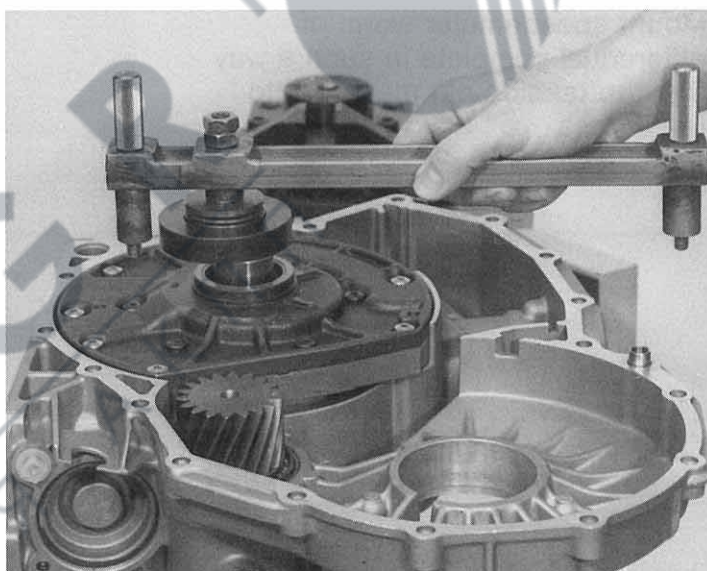

85 351

Use the special ring 5 X 46 000 327 to press in the tapered roller bearing inner ring 09.252 under the mandrel press.

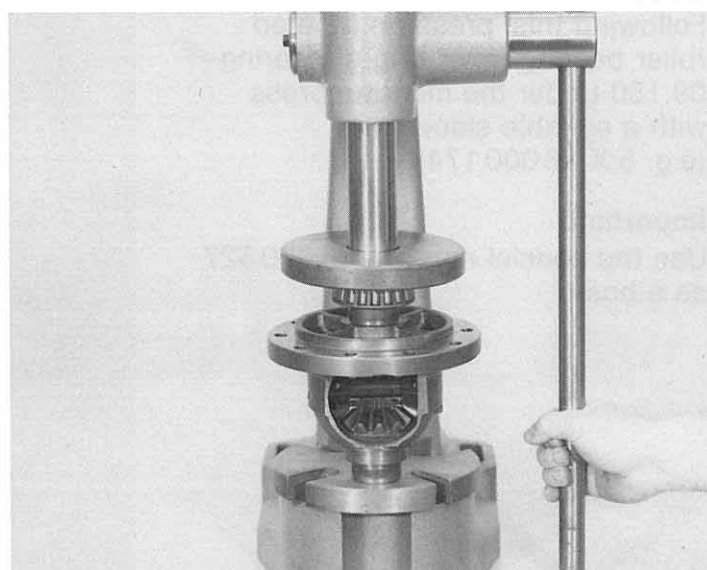

85 352

Knock the tension pin 08.032 into the speedometer worm 08.010 until it abuts.

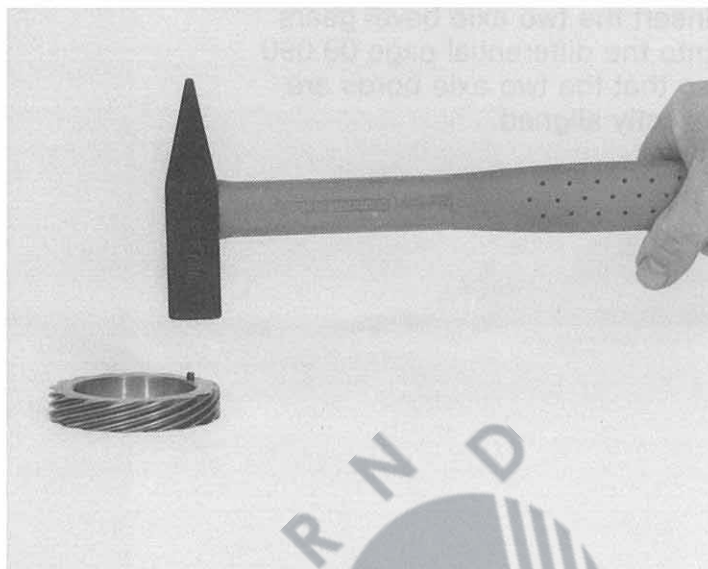

85 353

Mount speedometer worm of differential complete in such a way that the tension pin meshes into the recess.

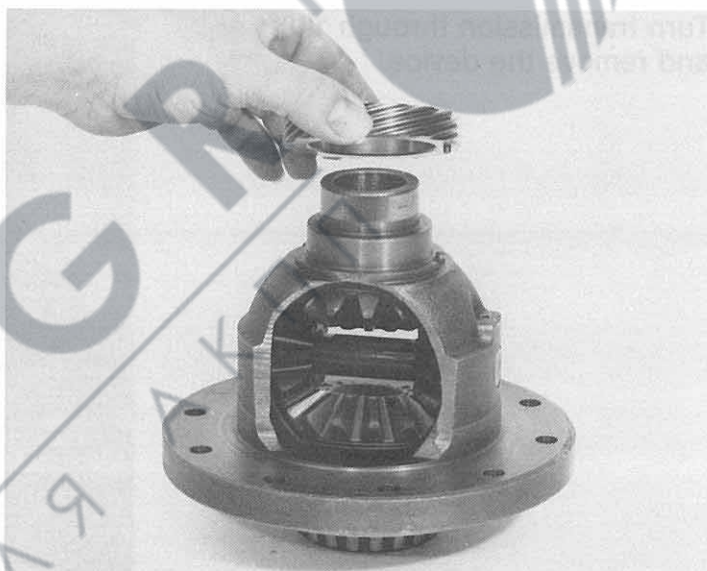

85 354

Following this, press on tapered roller bearing inner ring of bearing 09.180 under the mandrel press with a suitable sleeve (e.g. 5 X 46 000 174).

Important!

Use the special ring 5 X 46 000 327 as a base.



85 355

Clamp special aid 5 X 46 000 305 in a vice, insert differential and secure spur gear 09.100 with 10 locking bolts 09.110.

(Width across flats = 15 mm)
(Tightening torque = 77 Nm)

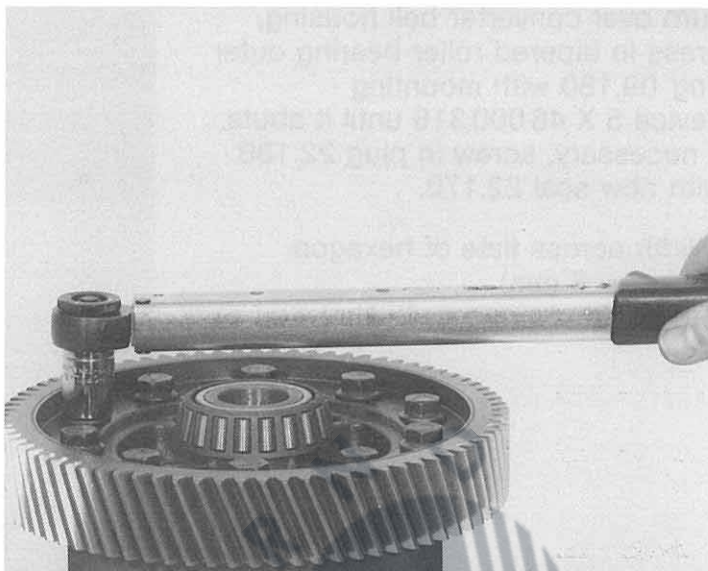

85 356

Insert differential cpl. into transmission housing.

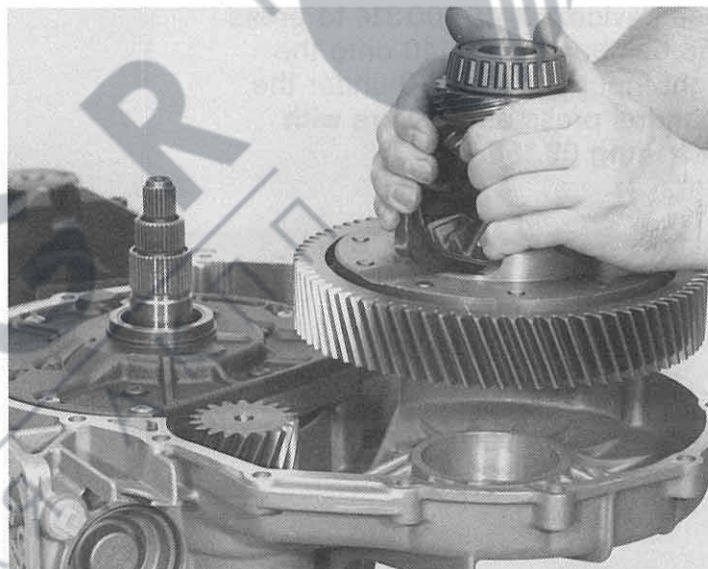

85 357

Use the mounting mandrel 5 X 46 000 369 to press the shaft seal 22.130 into the converter bell housing 22.010 under the mandrel press. Coat shaft seal with grease (Vaseline).

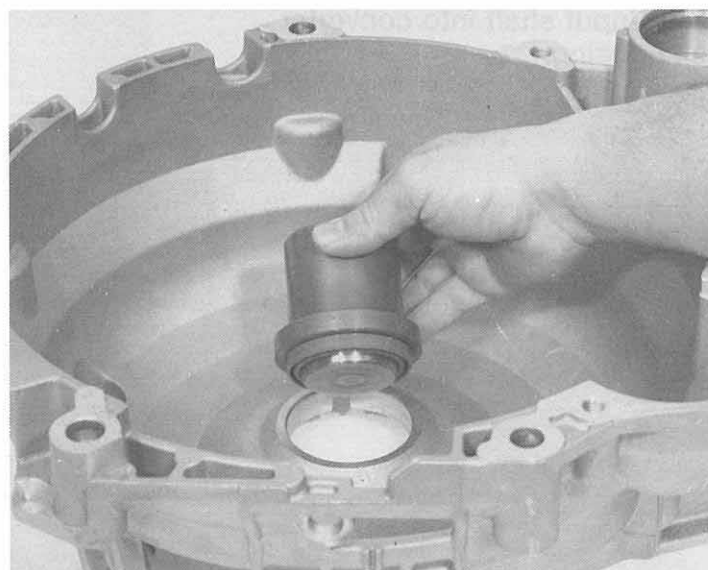

85 358

Turn over converter bell housing, press in tapered roller bearing outer ring 09.180 with mounting device 5 X 46 000 316 until it abuts. If necessary, screw in plug 22.180 with new seal 22.170.

(Width across flats of hexagon socket = 8 mm)
(Tightening torque = 45 Nm)

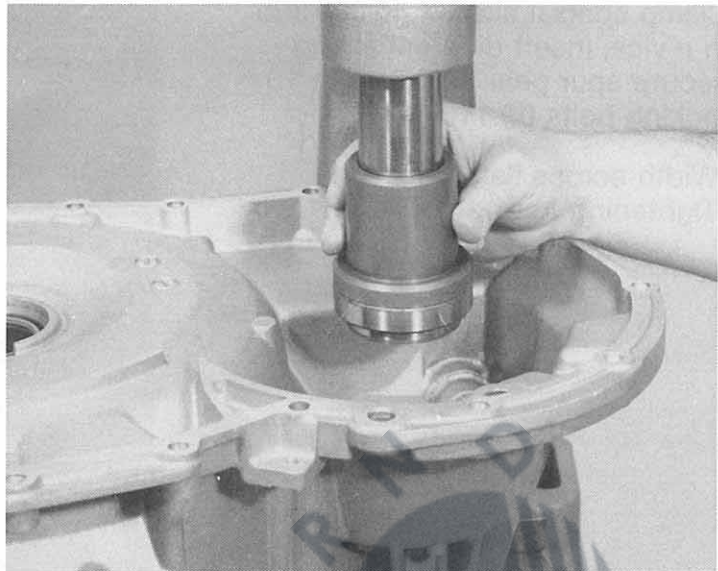

85 359

Use device 5 X 46 000 314 to press the ball bearing 09.140 onto the right input shaft 09.170 under the mandrel press **and secure with snap ring 09.150.**

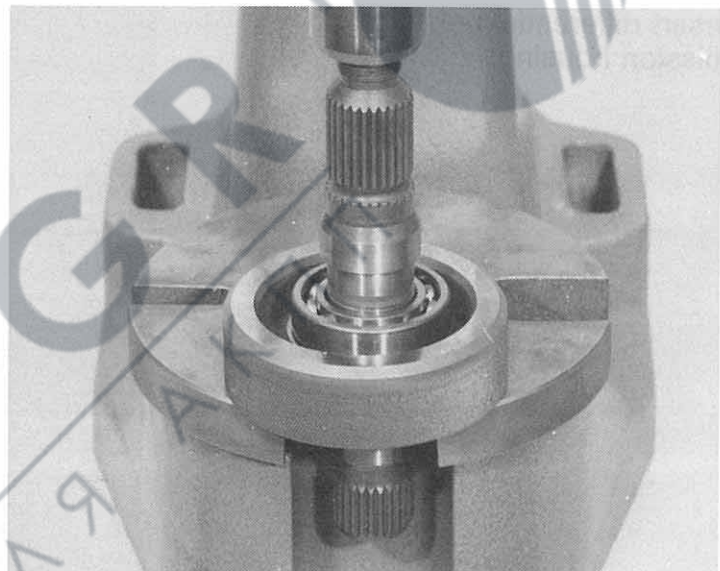

85 360

Insert input shaft into converter bell housing.

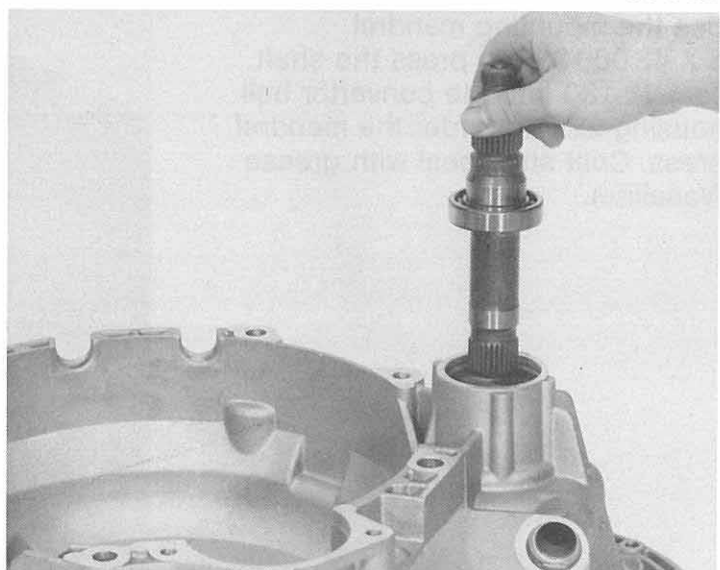

85 361

Using mounting device 5 X 46 000 317 install shaft seal 09.144 under the mandrel press.

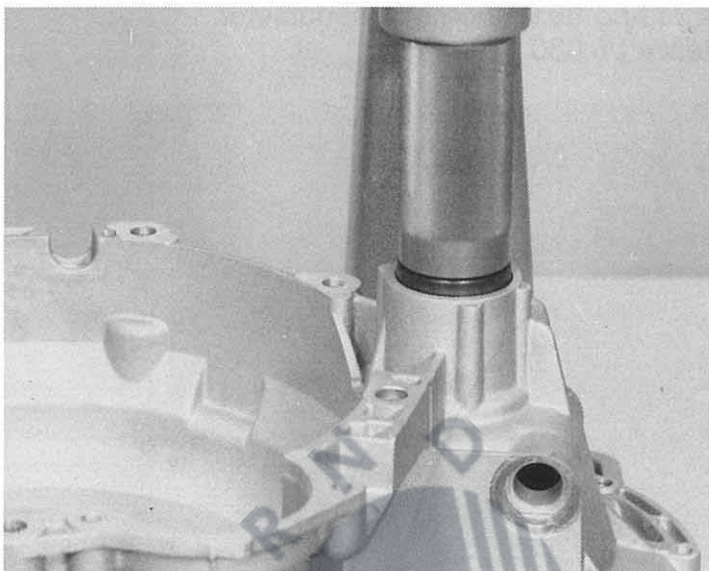

85 362

Secure the complete right input shaft with snap ring 09.130.

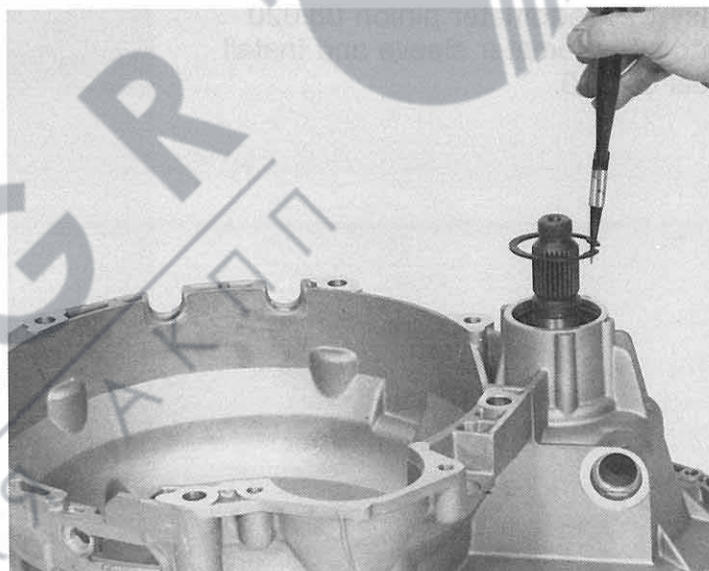

85 363

Slip on O ring 09.172 and fit on seal 09.174 until it abuts.

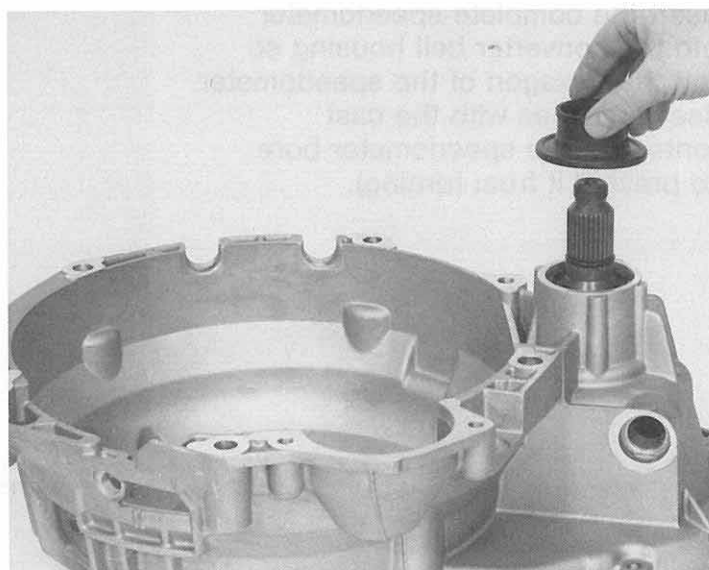

Fit O ring 08.040 onto speedometer sleeve 08.030.

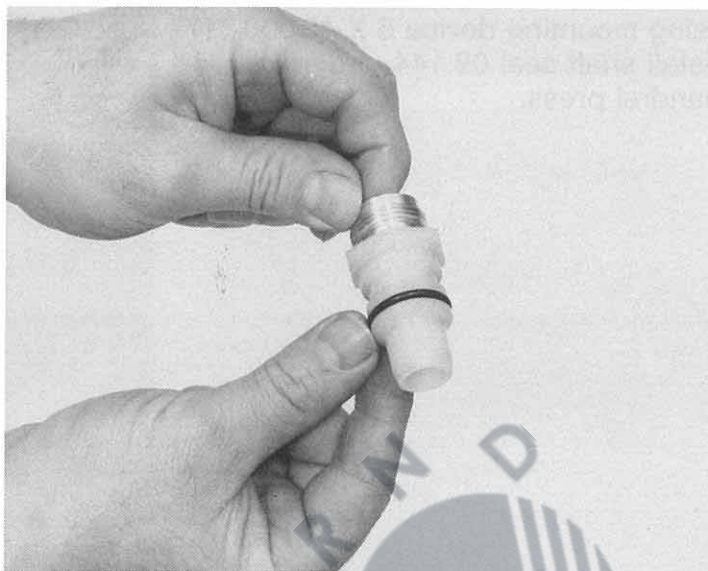

Insert speedometer pinion 08.020 into speedometer sleeve and install seal 08.050.



Insert the complete speedometer into the converter bell housing so that the hexagon of the speedometer sleeve meshes with the cast contour of the speedometer bore (to prevent it from turning).

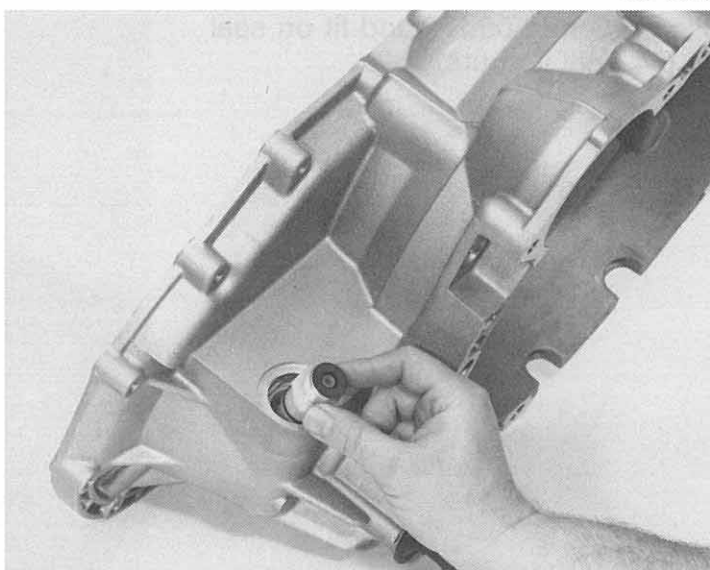

85 367

Press in new retaining ring 08.060
with mounting sleeve 5 X 46 000 284.

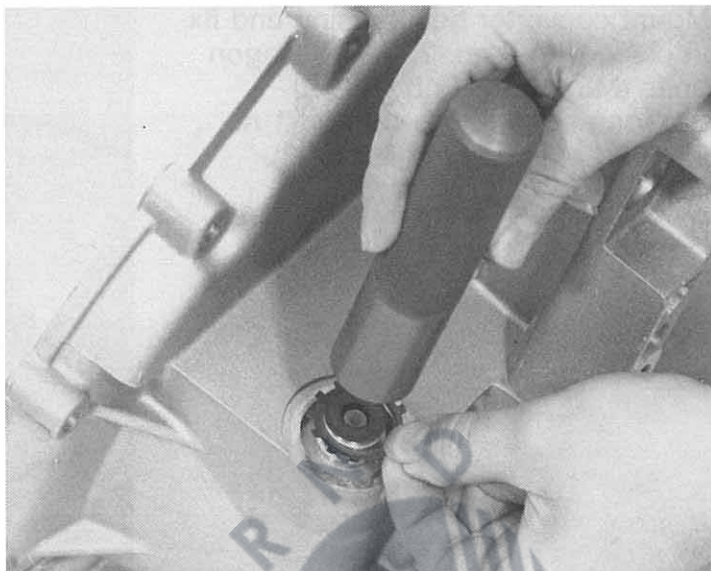

85 368

Screw on cap 08.070 as a protection.

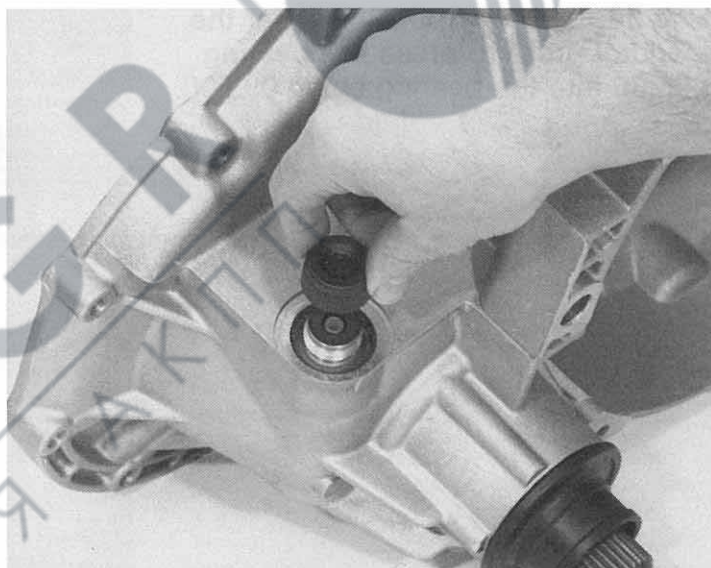

85 369

Use grease (Vaseline) to stick on
gasket 22.140 and align.

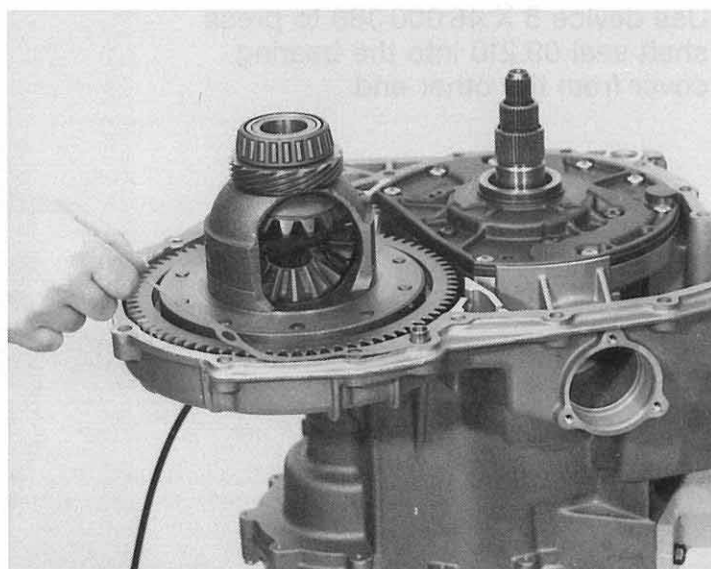

85 370

Mount converter bell housing and fix in place with 6 no. 22.150 hexagon bolts (M8 x 25), 11 no. 22.160 hexagon bolts (M8 x 42) and 1 no. 22.164 hexagon bolt (M8 x 50).

(Width across flats = 13 mm)
(Tightening torque = 23 Nm)

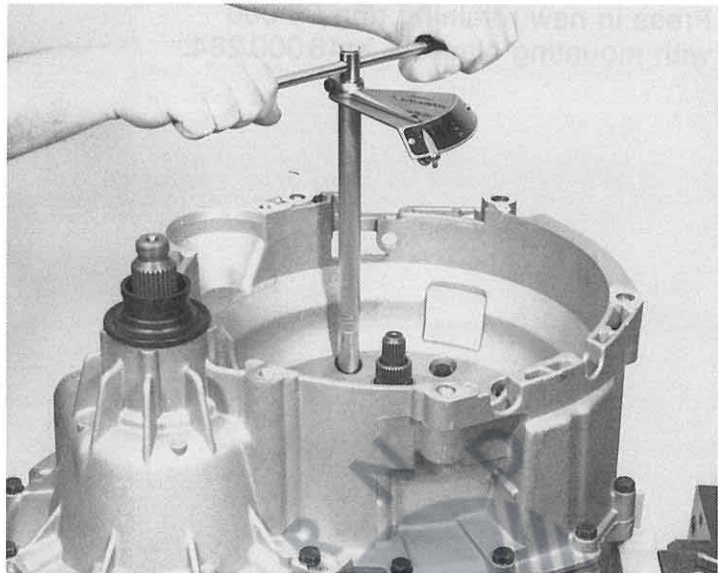

85 371

Use device 5 X 46 000 315 under the mandrel press to press ball bearing 09.230 into the bearing cover 09.200.

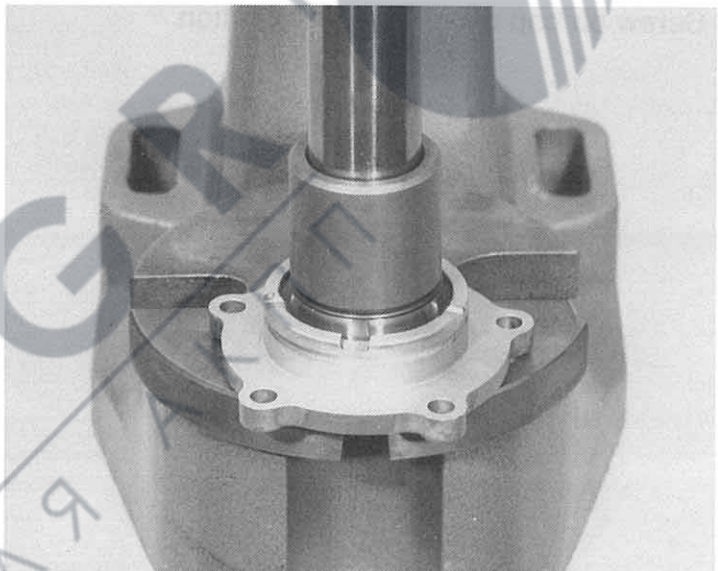

85 372

Use device 5 X 46 000 368 to press shaft seal 09.210 into the bearing cover from the other end.

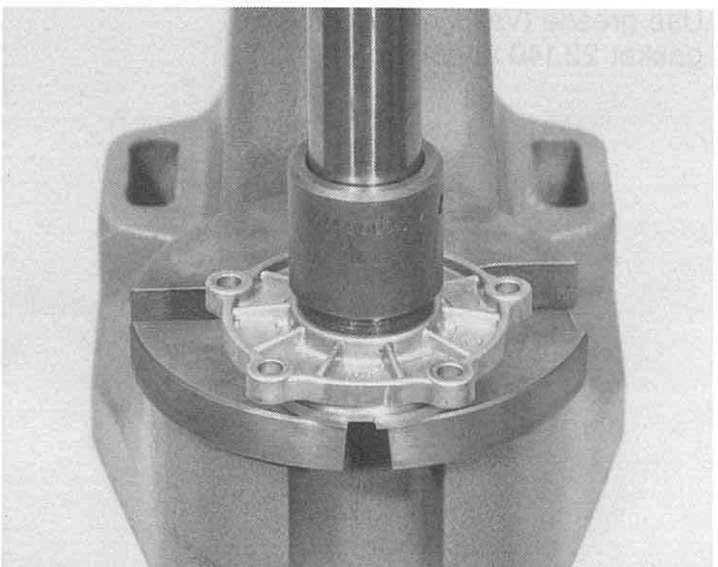

Press the left input shaft 09.250 into bearing cover under the mandrel press.

Use mounting device 5 X 46 000 314 as a base.

Secure input with shaft locking ring 09.234.

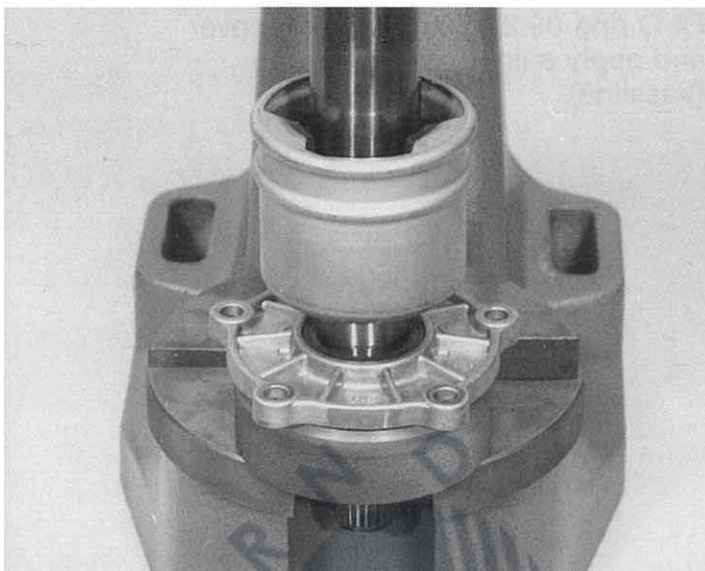

Insert tapered roller bearing outer ring 09.252 into transmission housing. If necessary, use hot-air fan to heat up the housing a little.

Important!

The tapered roller bearing outer ring must abut against the inner ring.



Insert washer 09.260.

Important!

Adjustment
(Refer to Point 1.4.7, p. 5/16).



85 374

Fit O ring 09.220 onto bearing cover and apply a light coat of grease (Vaseline).

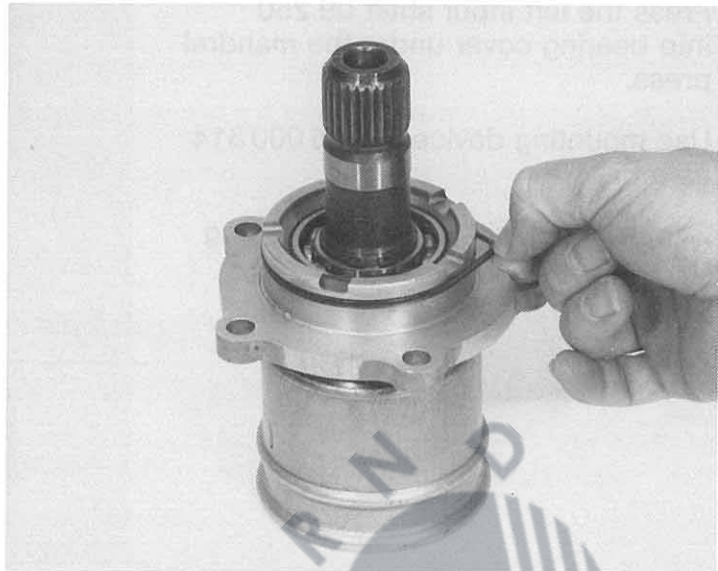

85 375

Use grease (Vaseline) to stick compression spring 09.244 and tappet 09.248 into the input shaft.

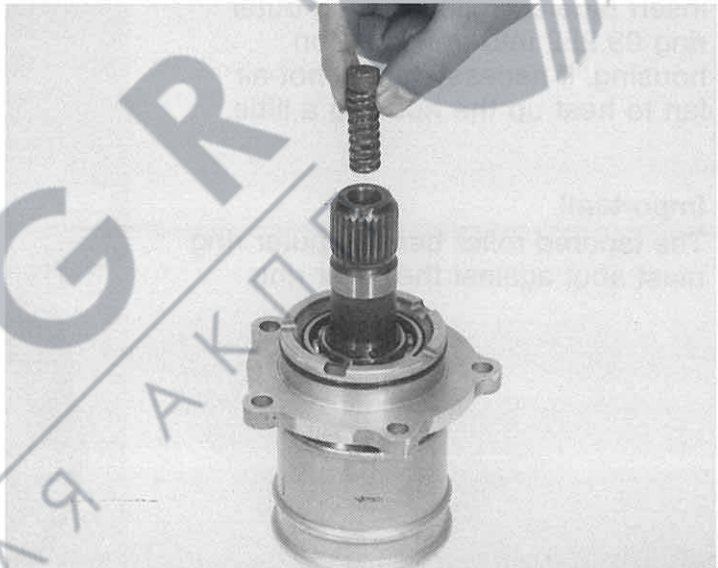

85 347

The cover 09.300 (spur gear train) can now be fitted. First of all, stick on gasket 09.290 with grease (Vaseline) and align. Fix cover in place with 13 cylindrical bolts 09.310.

(Width across flats
= Torx socket - TX 27)
Tightening torque = 10 Nm)

Refer to Point 3.9 Governor,
counter shaft and spur gear train,
p. 94.

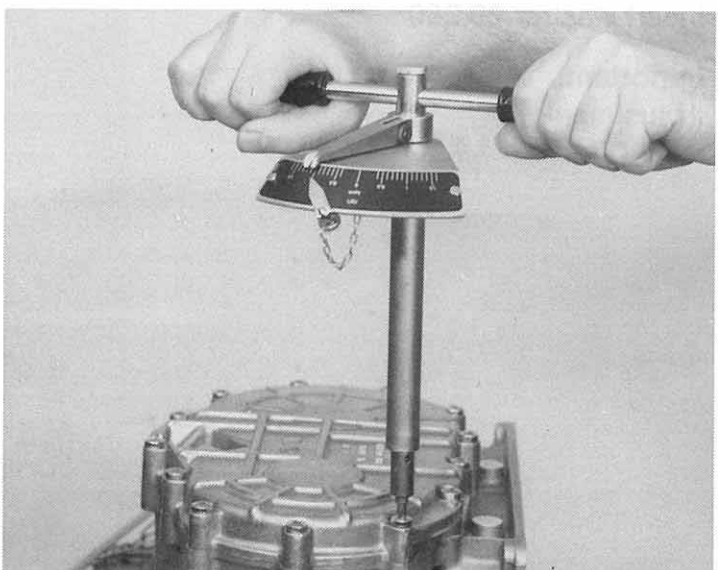

Insert the completed left input shaft and screw on tightly to the housing along with the bearing cover using 5 hexagon bolts 09.270 (tighten crosswise),

(Width across flats = 13 mm)

(Tightening torque = 23 Nm)

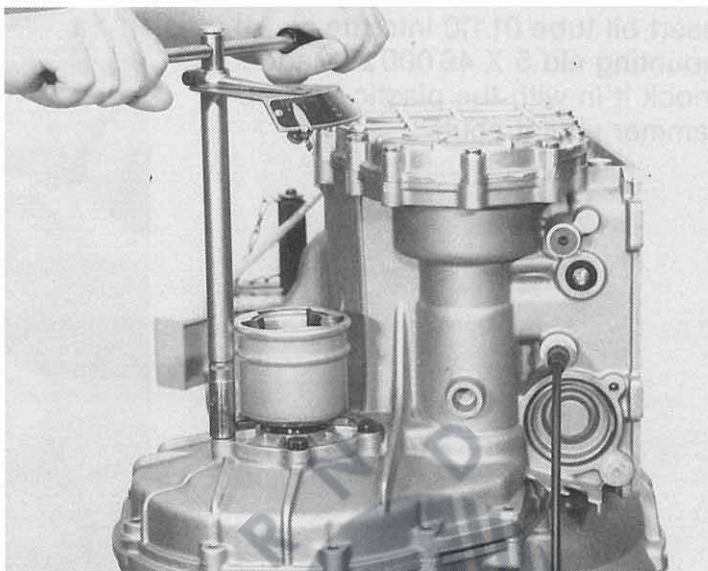

3.11 Control unit, oil pan, oil filter and converter

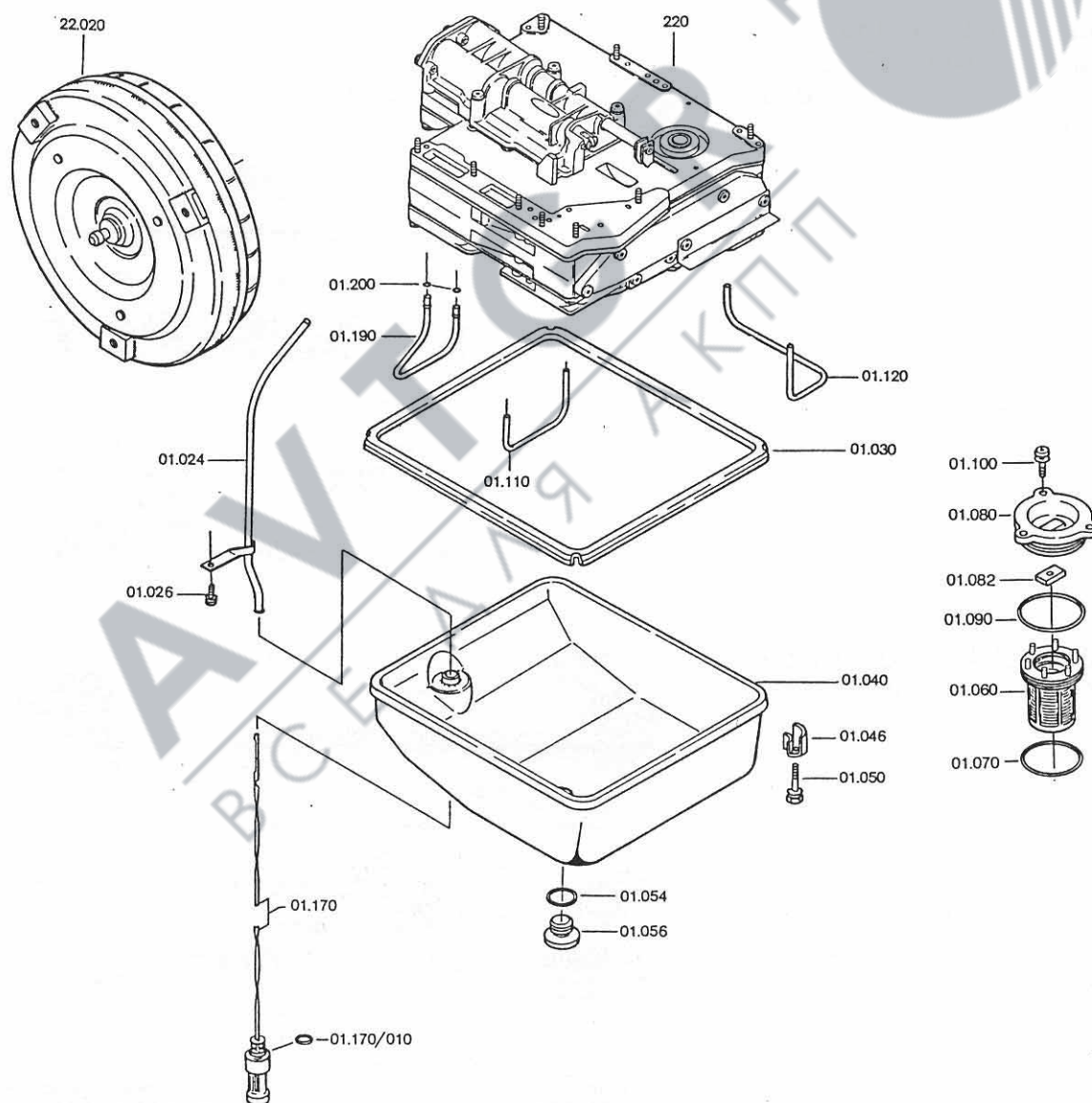

The brake must be adjusted before installing the control unit (Refer to Point 1.4.8, p. 5/19).

Insert oil tube 01.110 into the mounting aid 5 X 46 000 279 and knock it in with the plastic-headed hammer until it abuts.

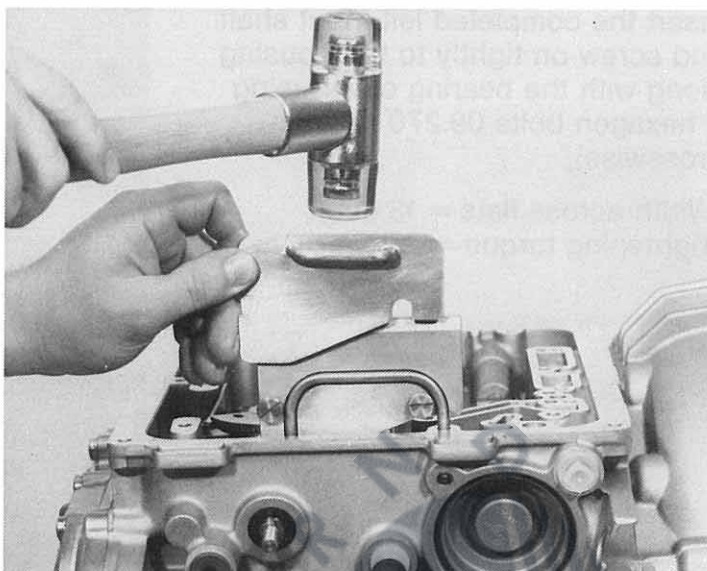

Insert oil tube 01.120 into the mounting aid 5 X 46 000 280 and knock it in with the plastic-headed hammer until it abuts.

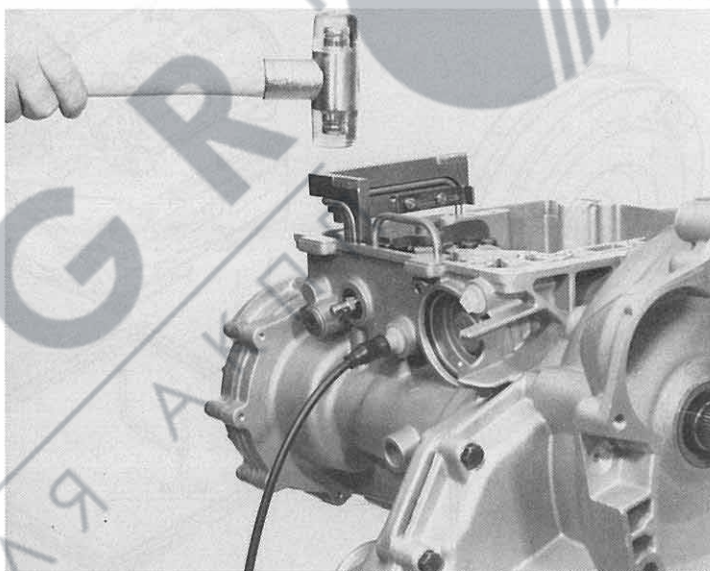

Secure tube 01.024 in the position shown opposite with cylindrical bolt 01.026.

(Width across flats
= Torx socket – TX 27)
(Tightening torque = 5 Nm)

Important!

Turn transmission through 90° to prevent the cylindrical bolt from falling into the housing.

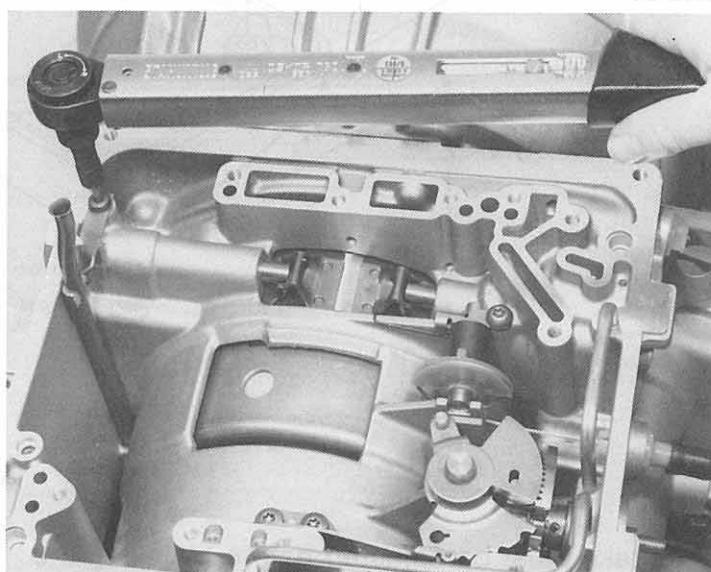

85 392

Set stop plate to Pos. 1 of selector valve with adjusting wrench 5 P 95 000 285.

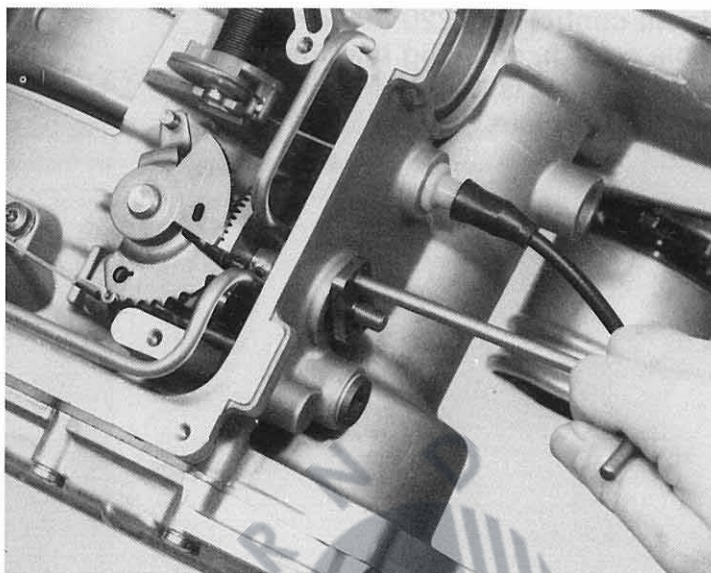

85 393

Pull accelerator cam with the accelerator cable far enough to prevent the accelerator cam from becoming jammed with the throttle piston.

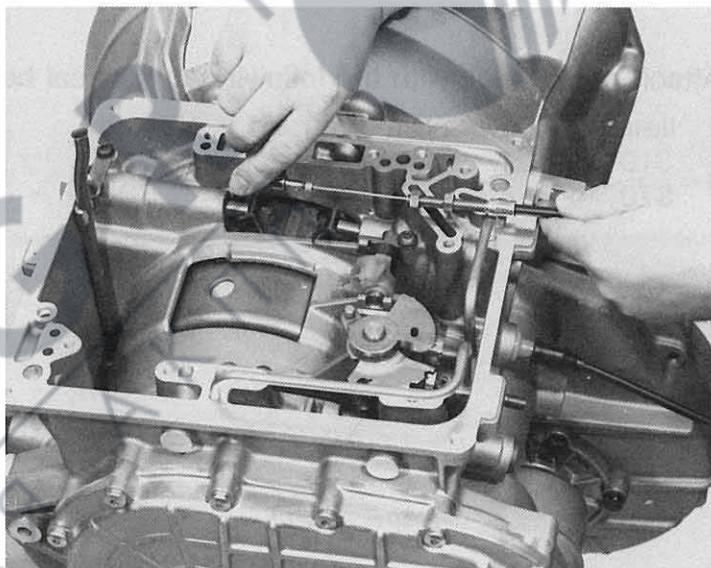

85 394

Set selector valve in the control unit to Pos. 1 (push in fully).

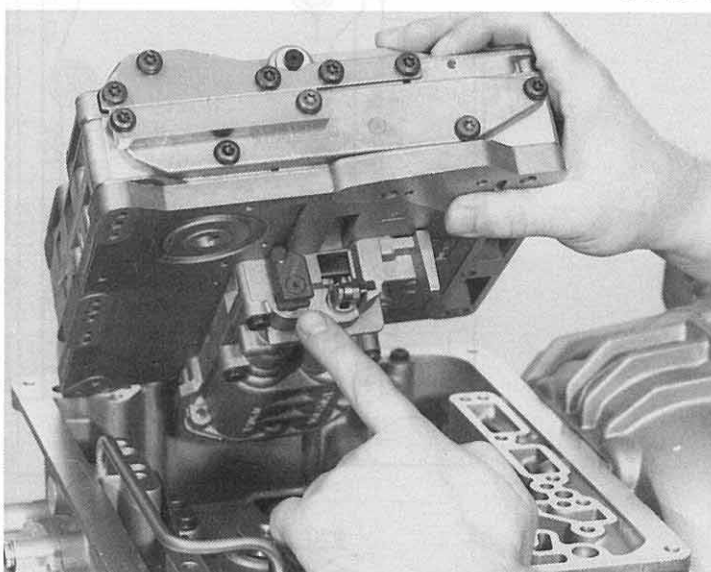

Mount control unit 220 (accelerator cable pulled), ensuring that the selector valve is inserted in the pin of the stop plate.

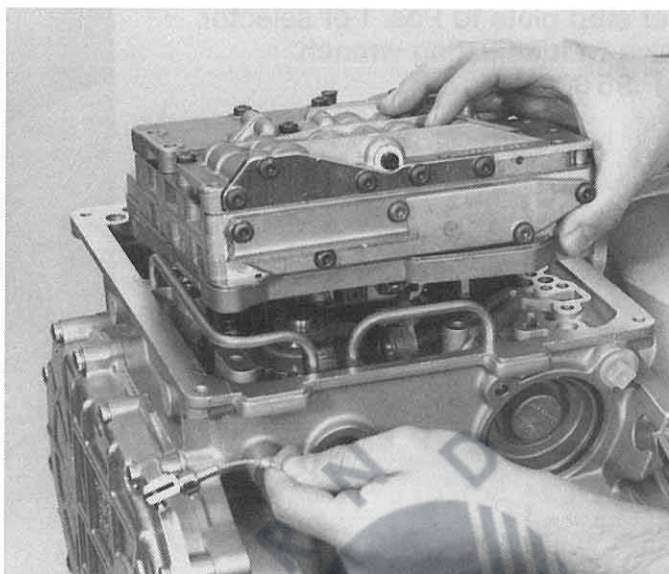

Attach control unit with the following cylindrical bolts:

Item	Qty.	Dia of thread	Length
310	1	M 6	35
970	8	M 6	70

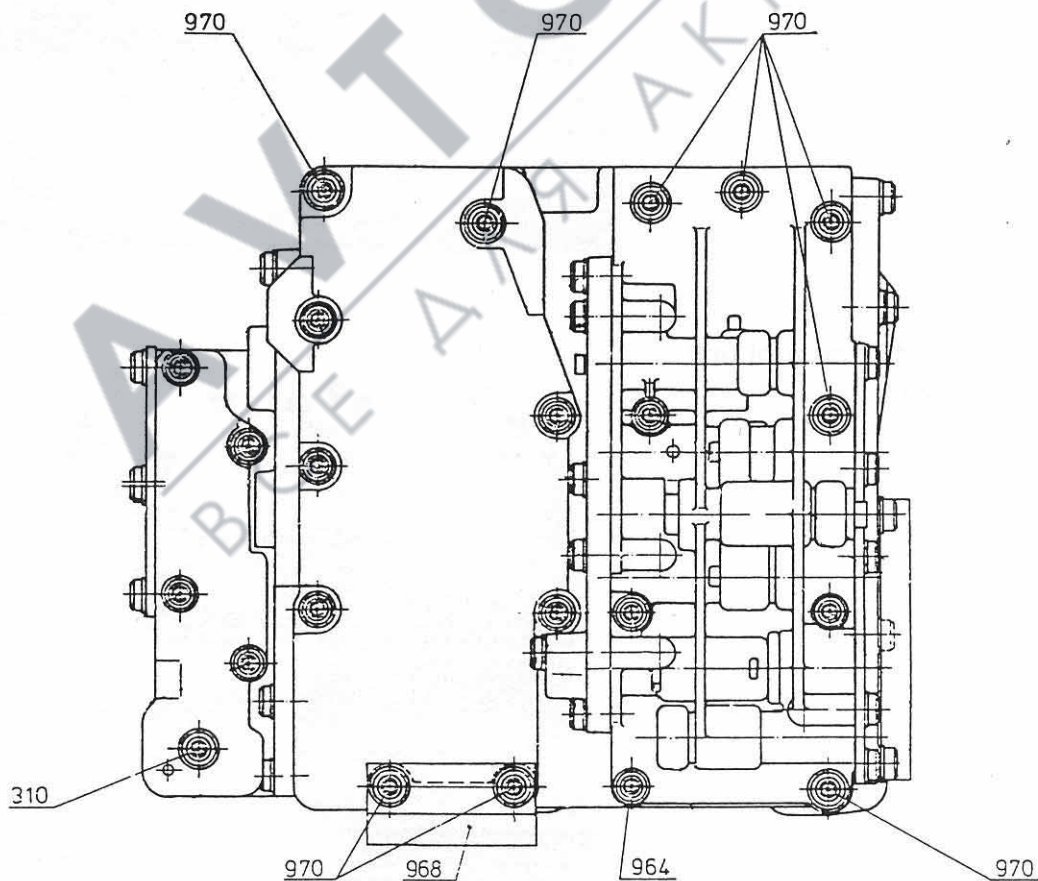

Tighten all the fastening bolts of the control unit, securing supporting plate 29.968 at the same time.

(Width across flats
= Torx socket – TX 27)
(Tightening torque = 8 Nm)

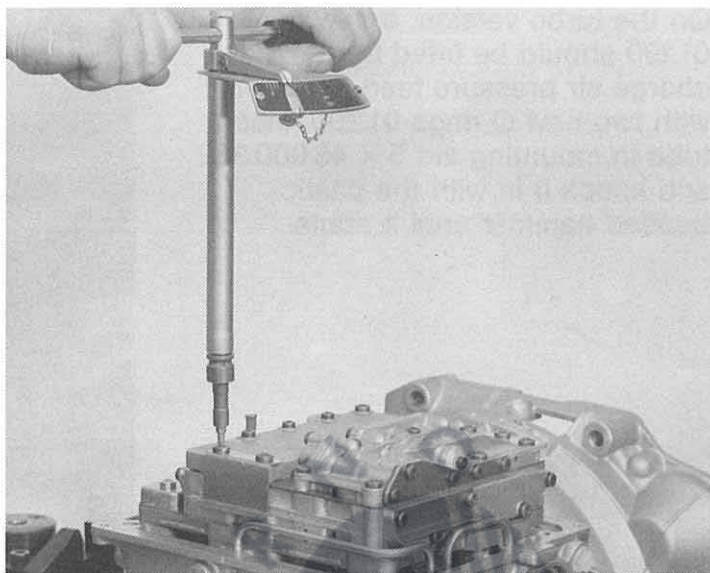

Important!

It is recommended to immediately adjust accelerator cable following this step and to fit the lead seal. This prevents the cable from coming off the accelerator cam. (Refer to Point 1.4.9, p. 5/20).



Perform an operational check of the accelerator cable and the selector mechanism.

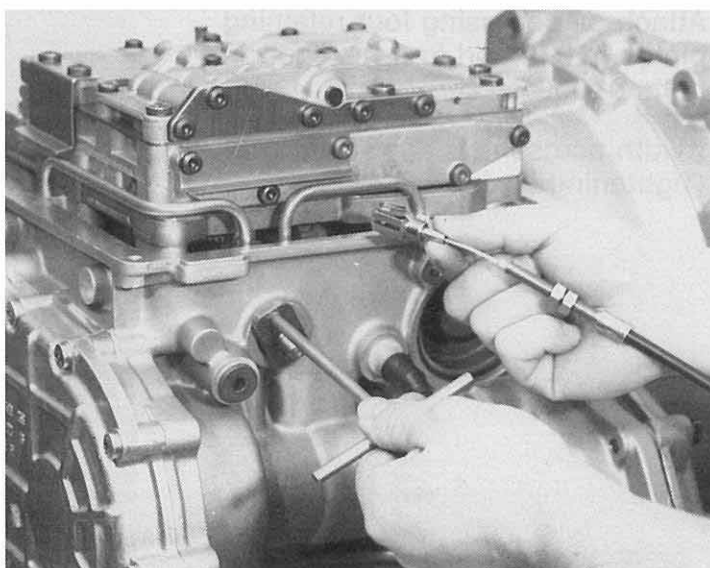

85 400

On the turbo version, a new tube 01.190 should be fitted for the charge air pressure feed together with two new O rings 01.200. Insert tube in mounting aid 5 X 46 000 352 and knock it in with the pastic-headed hammer until it abuts.

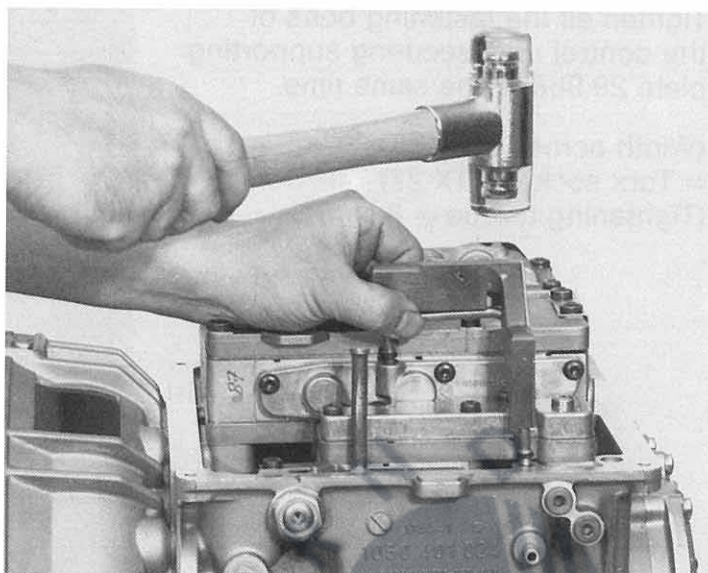

85 402

Fit gasket 01.030 onto the edge of the oil pan 01.040.

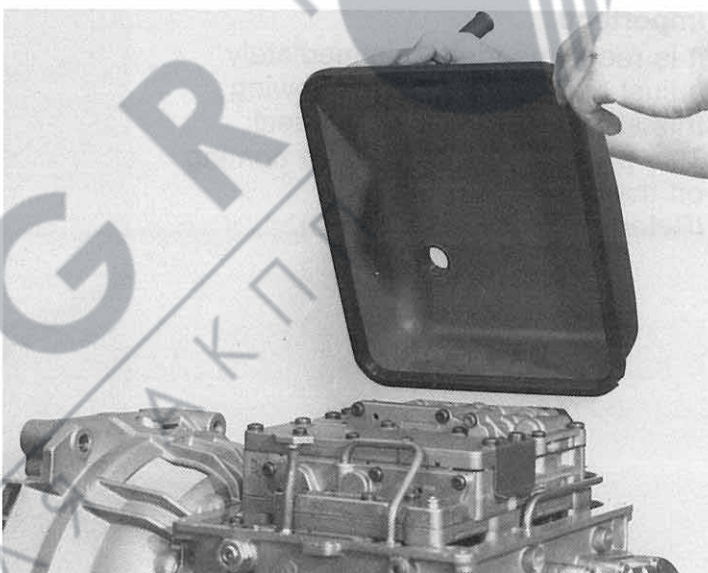

85 403

Attach oil pan using four retaining plates 01.046 and four hexagon bolts 01.050.

(Width across flats = 10 mm)
(Tightening torque = 6 Nm)



85 404

Fit screw plug 01.056 with new seal 01.054 into oil pan.

(Width across flats of hexagon socket = 12 mm)

(Tightening torque = 80 Nm)

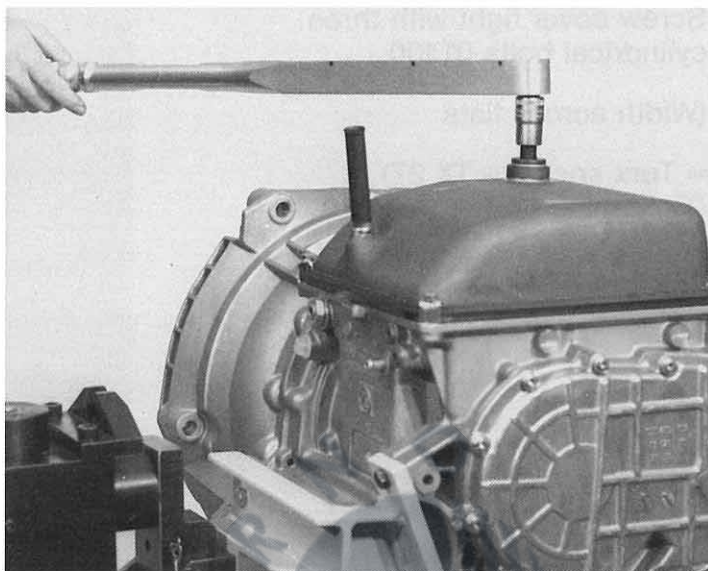

85 405

Turn transmission through 180°. Fit O ring 01.070 onto filter element 01.060 and install filter element.

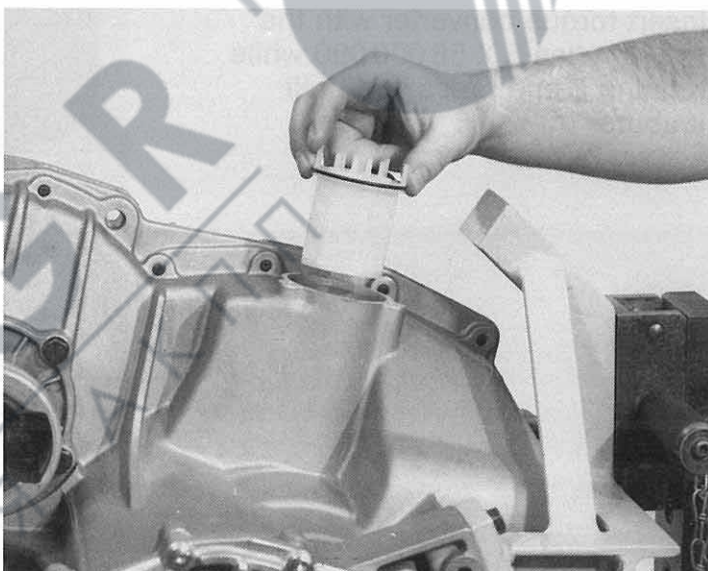

85 406

Fit O ring 01.090 onto cover 01.080 and use grease (Vaseline) to stick in magnets 01.082.

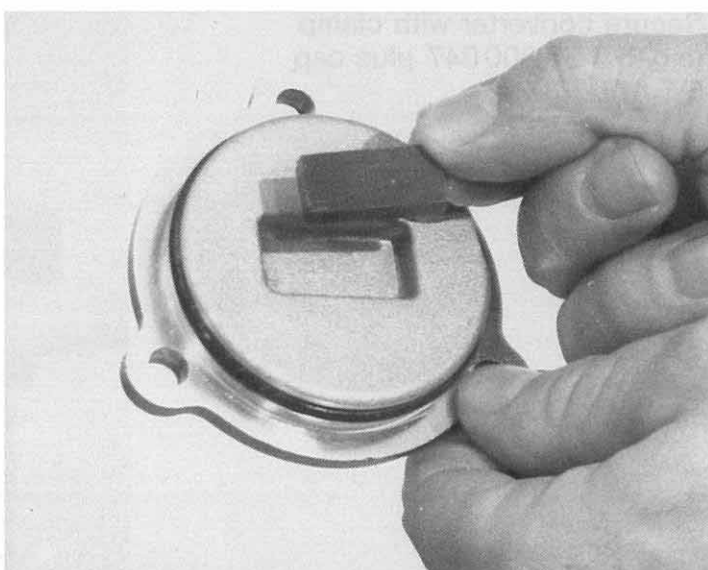

85 407

Screw cover tight with three cylindrical bolts 01.100.

(Width across flats

= Torx socket – TX 27)

(Tightening torque = 8 Nm)



85 408

Insert torque converter with the two handles 5 X 56 000 090 while rotating it and press it in until it abuts.

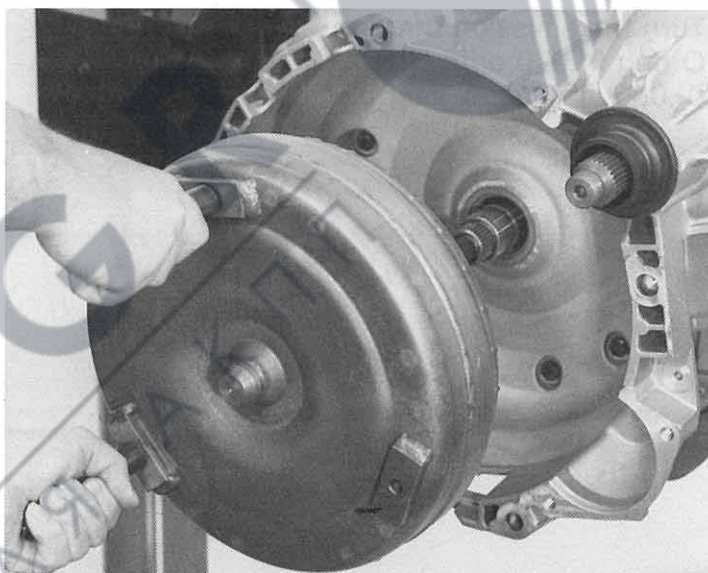

85 410

Secure converter with clamp (e.g. 5 T 95 000 047 plus cap 5 T 47 000 034).

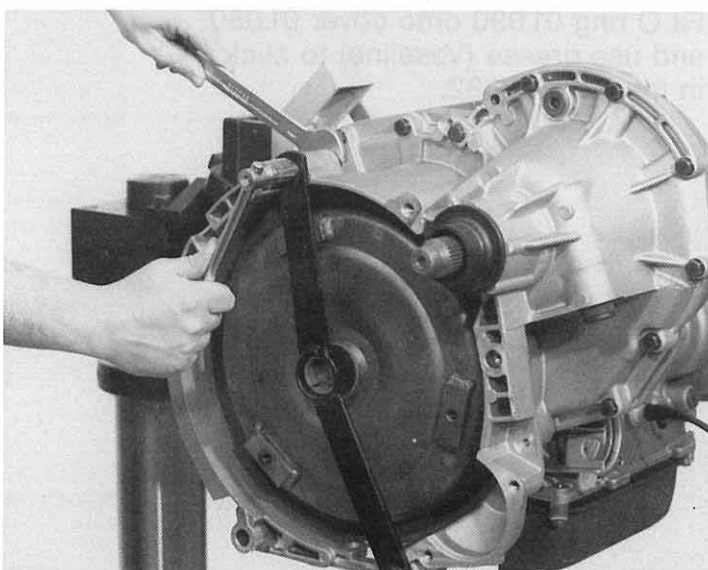

Turn transmission through 180°, fit new O ring 01.171/010 onto the dipstick 01.170 and insert dipstick into oil pan.

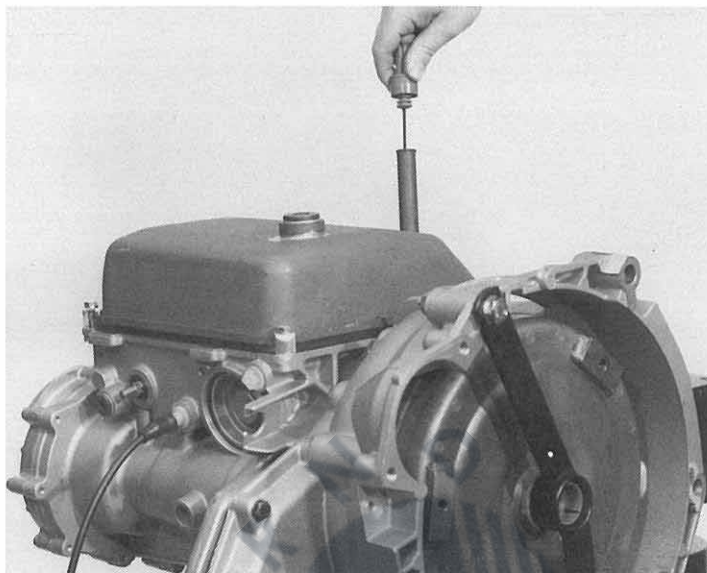

AVTGR
ВСЕ ДЛЯ АКПП



Impressum:

Verantwortlich für den Inhalt
Abteilung MKD, ZF Getriebe GmbH,
Saarbrücken
Druck: Hermann Hager GmbH, Quierschied
Gedruckt in der BRD

Published by ZF Getriebe GmbH,
Saarbrücken, Department-MKD
Printed in West Germany by
Hermann Hager GmbH, Quierschied.