

REPAIR MANUAL

6 HP-21



ZF GETRIEBE GMBH SAARBRÜCKEN

Version 07/10/01
CD



subject to alterations

© Copyright 2007 all rights reserved and published by
ZF Getriebe GmbH, Saarbrücken, Department MKTD

No part of this manual may be reproduced or transmitted in any form or
by any means, electronic or mechanical, including photocopying and recording,
for any purpose without the express written permission of
ZF Getriebe GmbH, Saarbrücken

Printed in Germany

Contents

Advance Information	iii
1. General	1.1/1
1.1 Illustration of transmission	1.1/1
1.2 Power flow diagram	1.2/1
1.3 Specifications	1.3/1
1.3.1 Screw specifications	1.3/1
1.3.1.1 Mechatronic type E	1.3/1
1.3.1.2 Mechatronic type M	1.3/1
1.3.1.3 oil sump	1.3/1
1.4 Adjusting work	1.4/1
1.4.0 Checking measurements of disk clusters (procedure)	1.4/1
1.4.1 Adjusting released clearance, brake C (snap ring)	1.4/3
1.4.2 Adjusting released clearance, brake D (end disk)	1.4/5
1.4.3 Adjusting released clearance, clutch B (snap ring)	1.4/7
1.4.4 Adjusting released clearance, clutch A (snap ring)	1.4/9
1.4.5 Release clearance, clutch E (snap ring)	1.4/11
1.4.6 Output side play (washer)	1.4/13
1.4.7 Input-side play (washer)	1.4/14
(M Type only)	
1.4.8 Switch setting (detent spring)	1.4/15
1.5 Tightening torques	1.5/1
1.6 Transmission test (test bench)	1.6/1
1.7 Special tools	1.7/1
1.8 Oilflow chart (Position N)	1.8/1
(E - type)	1.8/1
(M - type)	1.8/2
2. Disassembly	2.1/1
2.1 Disassembly of transmission according to component groups	2.1/1
Disassembly	
2.2 Turret (with clutches A and E)	2.2/1
2.3 Oil supply	2.3/1
2.4 Clutch B	2.4/1
2.5 Brakes C and D	2.5/1
2.6 Output shaft with parking lock	2.6/1
2.7 Transmission casing with shift- control and parking lock	2.7/1
3. Assembly	3.1/1
3.1 Gearbox housing with shift control and parking lock	3.1/1
3.2 Output shaft with parking lock and planetary gear set	3.2/1
3.3 Brakes C and D	3.3/1
3.4 Clutch B	3.4/1
3.5 Turret (drive with clutches A and E)	3.5/1
3.5.1 Clutch E (drive)	3.5/1
3.5.2 Clutch A (input)	3.5/4
3.6 Oil supply	3.6/1
3.7 Mechatronics, oil pan and converter	3.7/1



Advance Information

These instructions contain the procedure for repair work on the complete transmission.

The repair instructions will only be understood sufficiently in combination with ZFS training. Neglecting this could lead to installation errors.

All disassembly and assembly work is listed in chronological order.

Photos and illustrations for the various applications are general in character and not binding for every individual case.

Important changes and those relevant to specific applications that have to be considered during repair work are announced in *Technical Circular Letters* and training courses.

During the repair work SDM regulations and serviceline-specifications must be observed.

Please note the following:

- Seals, e.g. O-rings, shaft sealing rings, gaskets and filters must always be renewed.
- During assembly, all O-rings, cylindrical rings and other sealing rings must be greased with Vaseline before mounting.
- All bearings must be slightly oiled when installed.
- Exchange all lining and steel disks in transmissions with higher distance readings (> 80,000 kilometers / 50,000 miles).
- After clutch / brake damage, converters, oil pipes and oil coolers must be cleaned out thoroughly and sufficiently with an appropriate cleaning agent.

The following requirements should be satisfied before starting the repair work:

- Availability of the necessary special tools otherwise assembly faults are possible. Chapter 1.7 lists the complete set of special tools.
- Availability of a suitable transmission test rig. For the necessary test values, please refer to the *Technical Circular Letters*.

Note:

In the instructions the shift control unit is considered as a complete unit. It must not be dismantled without special experience, but should be exchanged as a complete unit.

It is planned to issue separate instructions for the control unit.

Warning:

The transmission is filled with lifetime oil.

An oil change is not necessary before 160 000 km or 10 years.

Make sure that the transmission is delivered with the oil quantity and oil type specified in the relevant part list document (see SDM).

Techn. KD

Techn. Documentation

KD Training

Bach

Reus

Schultz

1. General
1.1 Illustration of transmission

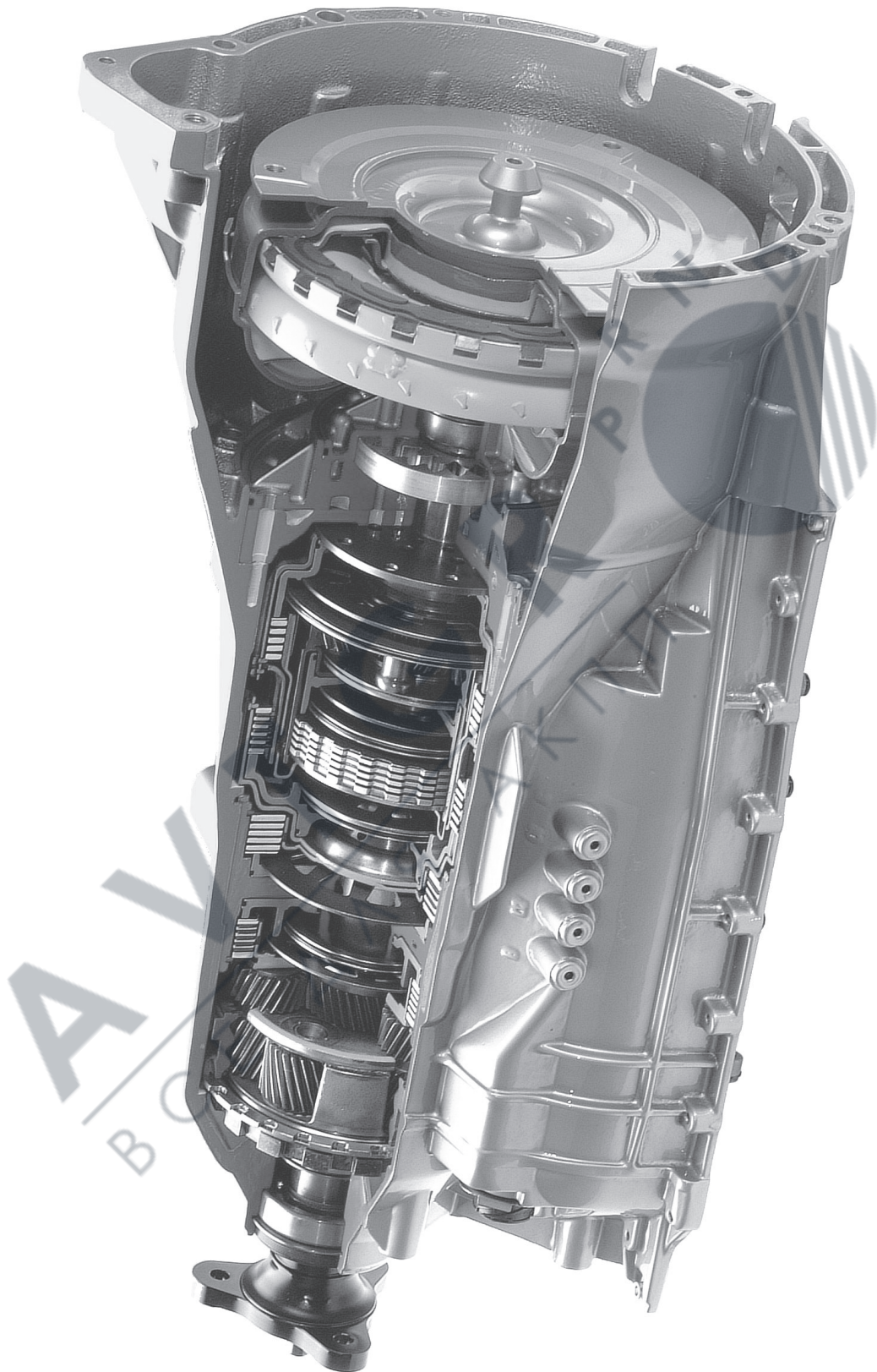



1.2 Power flow diagram

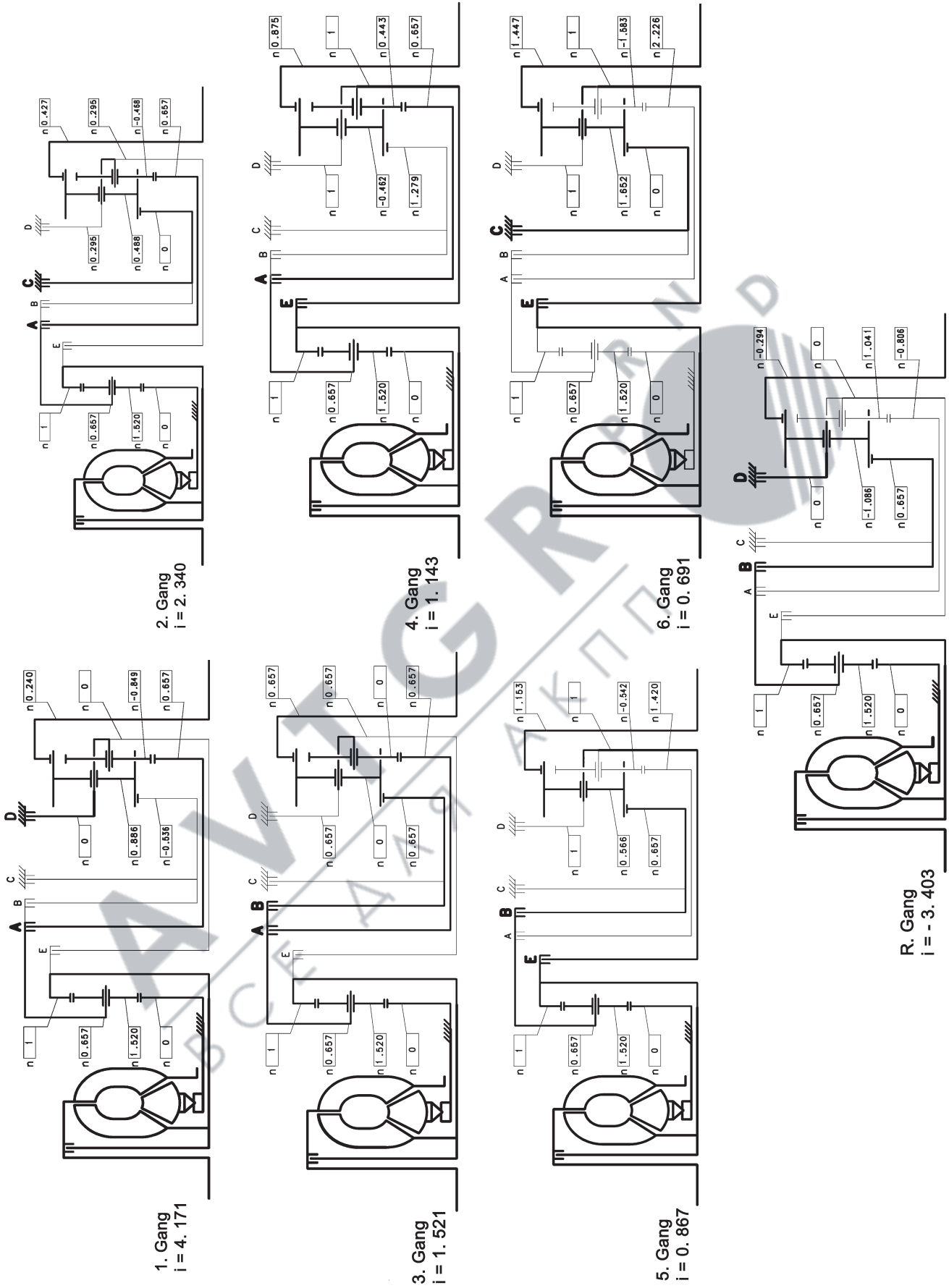



1.3 Specifications

1.3.1 Screw specifications

1.3.1.1 Mechatronic type E

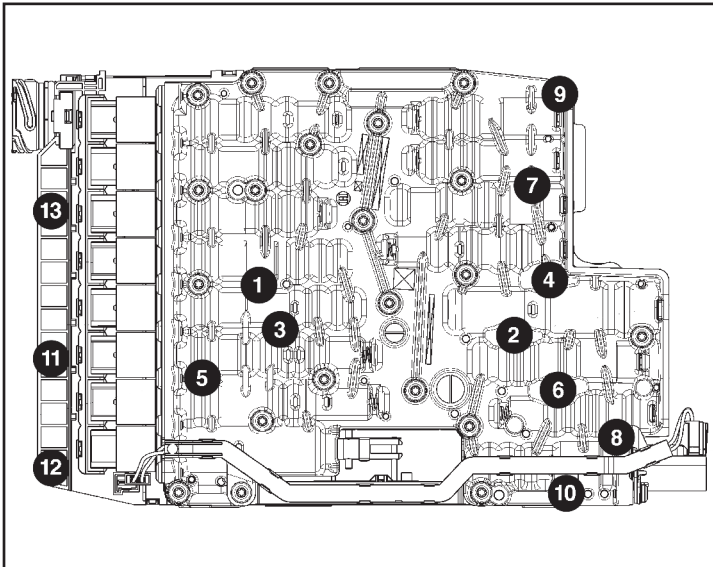

Tighten screws of the type E mechatronic in the order of the numbering (see diagram)

1 ⇔ 2 ⇔ 3 ⇔ ... ⇔ 13

Important!

Specification 1068 700 240

(Tightening torque: see Chapter 1.5)

1.3.1.2 Mechatronic type M

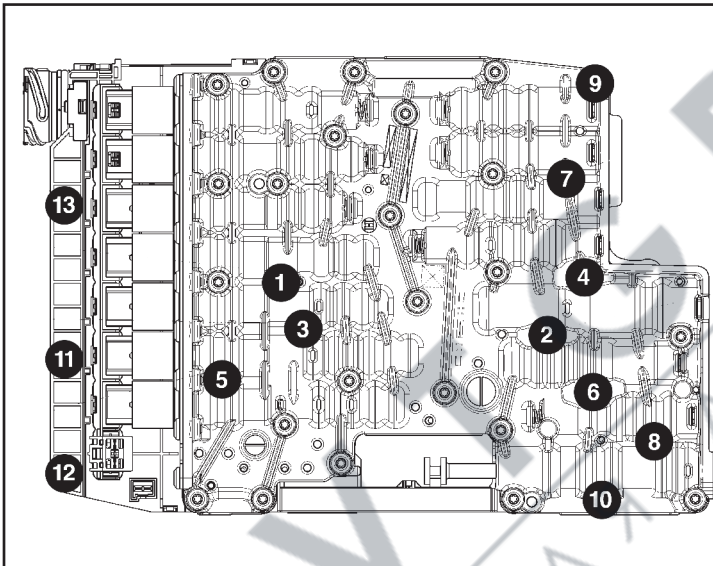

Tighten screws of the type M mechatronic in the order of the numbering (see diagram)

1 ⇔ 2 ⇔ 3 ⇔ ... ⇔ 13

Important!

Specification 1068 700 240

(Tightening torque: see Chapter 1.5)

1.3.1.3 oil sump

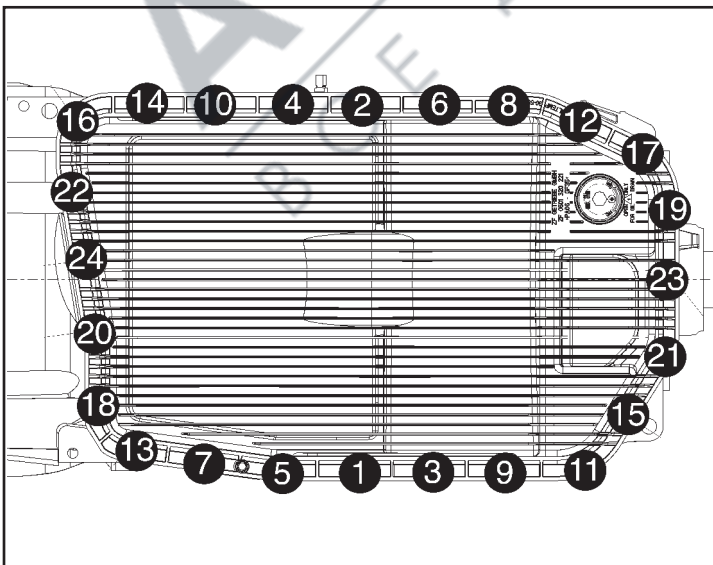

Tighten screws of oil sump in the order of the numbering (see diagram)

1 ⇔ 2 ⇔ 3 ⇔ ... ⇔ 24

Important!

Specification 1071 700 087

(Tightening torque: see Chapter 1.5)



1.4 Adjusting work

1.4.0 Checking measurements of disk clusters (procedure)

Place the two spacers 5p01 000 329 on the marked points of measuring fixture 5p01 000 330.

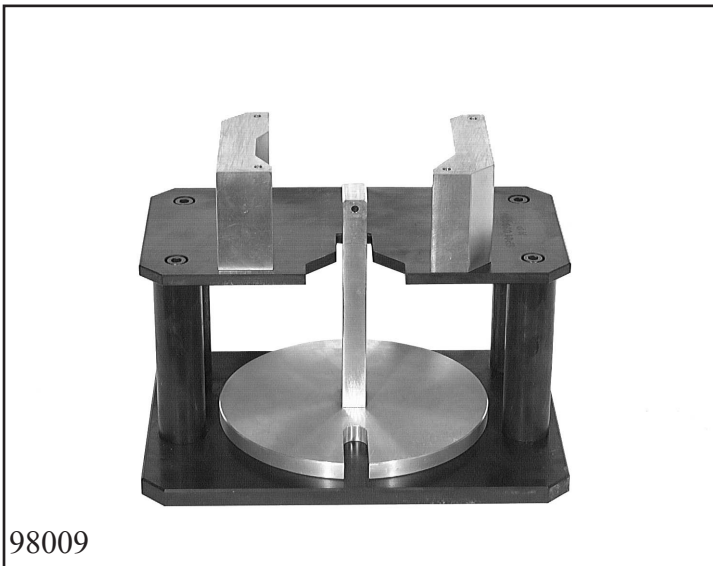

Use the knurled screw to turn adjusting fixture 5p01 001 458 to the upper limit position. Attach strain gauge 5p01 000 329 in the adjusting fixture.



Tighten the 4 knurled screws 5p01 000 329 to secure the adjusting fixture firmly with the height measuring fixtures by way of the spacers.

Connect measuring plate 5p01 040 330 to the strain gauge with the locating pin.

Clamp the disk cluster to be measured into the fixture at a tightening torque of 200 Nm, using the knurled screw (the corrugated steel disk, if present, must be at the bottom)

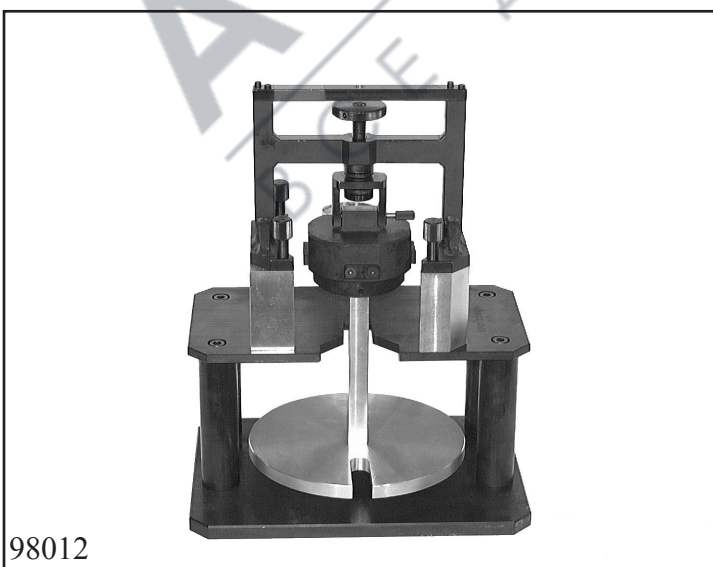

Check the value shown on the strain gauge.

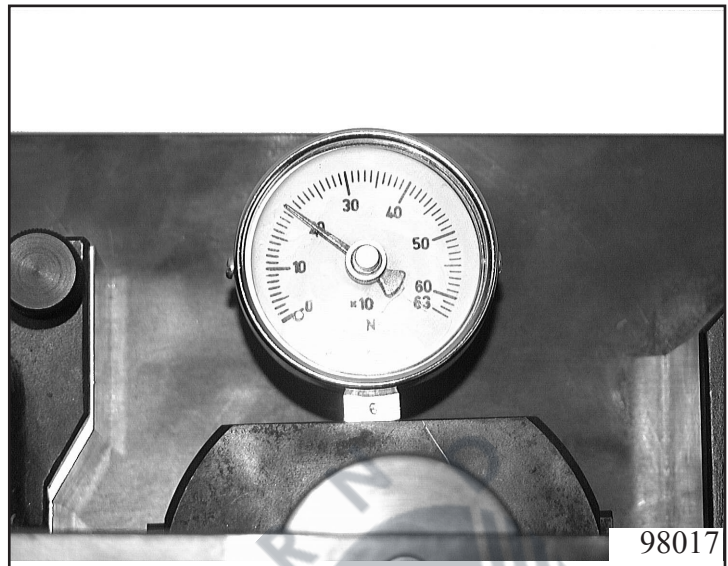

Next, place measuring bar 5p01 000 330 on the measuring plate, place the measuring foot of the dial gauge in the groove of the measuring plate on the upper disk of the disk cluster, and set the dial gauge to "0".

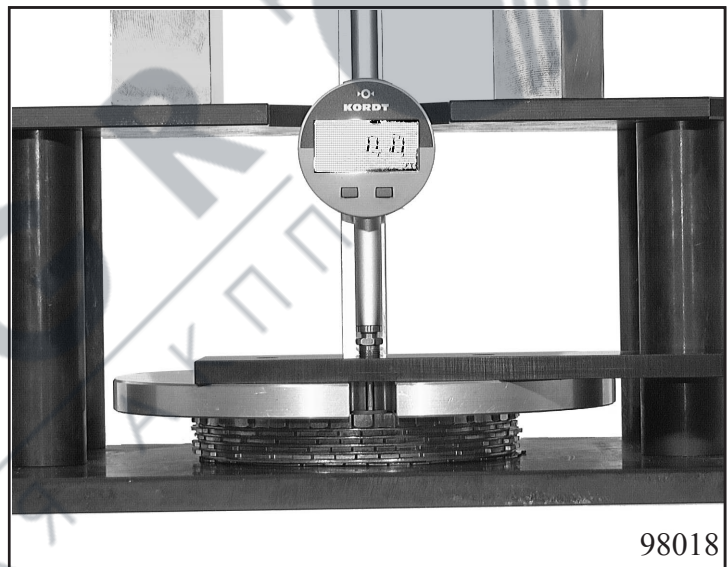

Measure down to the baseplate with the measuring bar.

Take the reading $\Rightarrow M_X$

Note:

The index **X** in M_X stands for the clutch brake cluster that has been inserted (A, B, C, D, E).

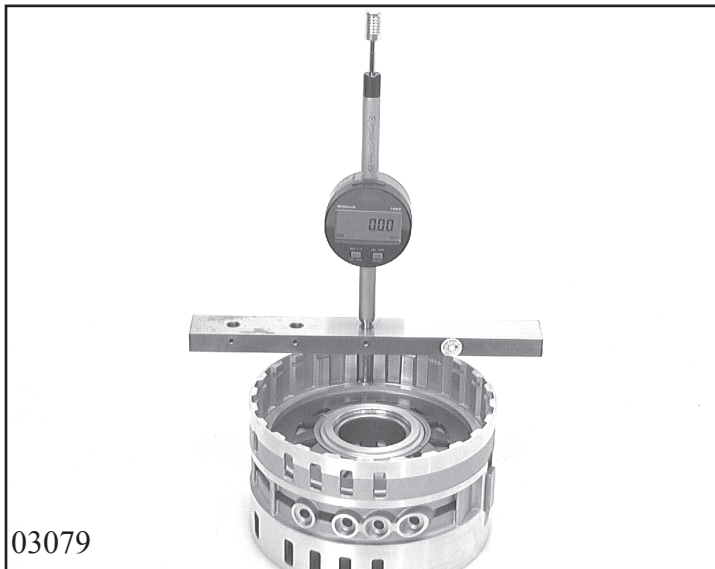

1.4.1 Adjusting released clearance, brake C (snap ring)

Determine installed space E_C for brake C with measuring bar 5p01 000 330. To do this, place measuring bar 5p01 000 330 on the edge of the cylinder of brake C. Place the dial gauge foot on the highest point of the disk contact face at the piston, and set the dial gauge to "0". Pull the measuring sensor up insert into snap-ring groove and press against upper edge of the groove.

Take the dial gauge reading $\Rightarrow W_C$

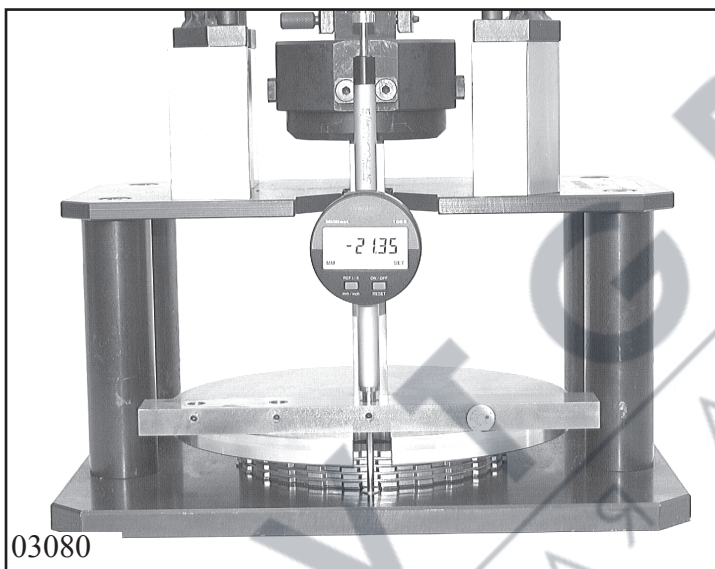

Determine thickness M_C of the brake C disk cluster as described in Chapter 1.4.0 "Measuring the disk clusters".

$\Rightarrow M_C$

Installed space E_C is obtained from measured value W_C plus foot thickness F . $\Rightarrow E_C$

Text value P_C is then obtained from installed space E_C minus M_C

Value P_C must be between 3.30 – 4.49 mm. Test directive 1071 700 104.

Version A

Use test gauge P_C to select snap ring S_C .

Calculation:

$$E_C = W_C + F$$

$$P_C = E_C - M_C$$

With 4 lined disks, released clearance L_C should be 1.30 – 1.59 mm.

Example (for 1.4.1):

$$F = 1.48 \text{ mm (thickness of foot)}$$

$$W_C = 23.78 \text{ mm}$$

$$M_C = 21.35 \text{ mm}$$

$$E_C = 23.78 + 1.48$$

$$= 25.26 \text{ mm}$$

$$P_C = 25.26 - 21.35$$

$$= 3.91 \text{ mm}$$

$$S_C = 2.40 \text{ mm}$$

$$L_C = 3.91 - 2.40$$

$$\Rightarrow L_C = 1.51 \text{ mm}$$



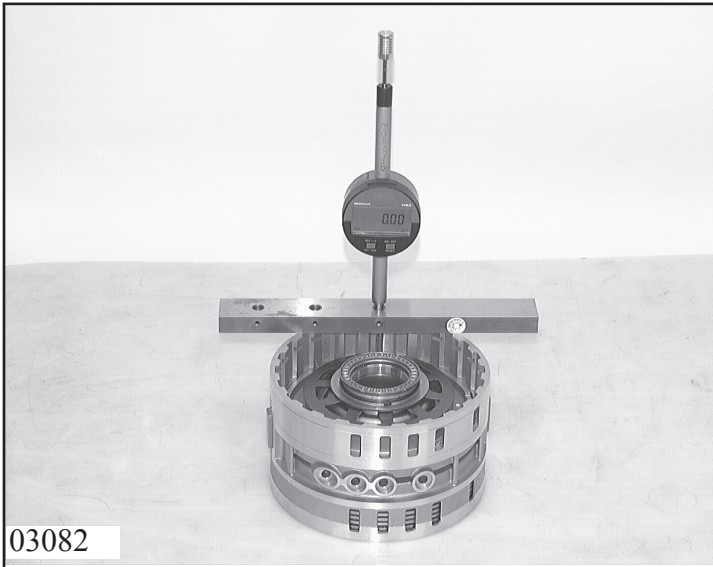

1.4.2 Adjusting released clearance, brake D (end disk)

Determine installed space E_D for brake D with measuring bar 5p01 000 330. To do this, place measuring bar 5p01 000 330 on the edge of the cylinder of brake D. Place the measuring foot on the highest point of the disk contact surface of the piston, and set the dial gauge to "0".

Pull the measuring sensor up, insert it into the snap ring groove and while doing so, press it against the upper edge of the groove.

Take the dial gauge reading $\Rightarrow W_D$

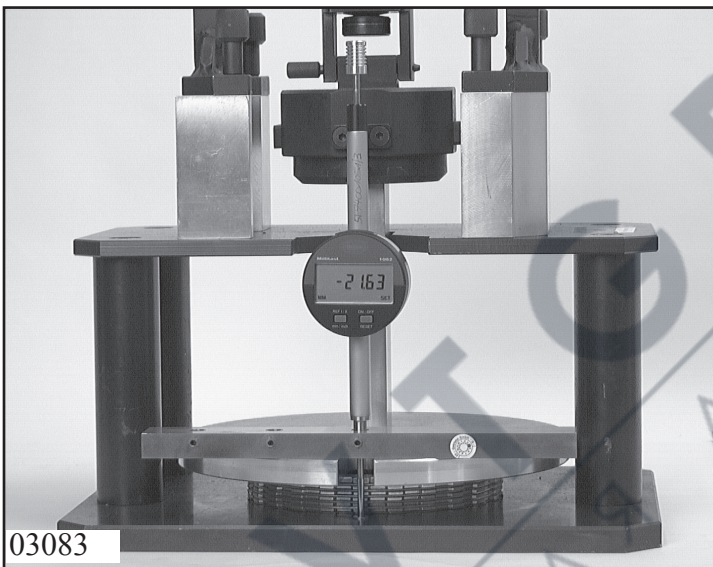

Determine thickness M_D of the brake D disc cluster as described in Chapter 1.4.0 "Measuring the disk clusters".

$\Rightarrow M_D$

Installed space E_D is obtained from W_D plus foot thickness F . $\Rightarrow E_D$

Text value P_D is then installed space E_D minus M_D .

Value P_D must be between 3.40 – 4.85 mm, Test directive 1071 700 065
Version A

Use text gauge P_D to select end disk S_D .

Released clearance L_D with 5 lined disks should be 1.59 – 1.88 mm.

Example (for 1.4.2):

$$\begin{aligned}W_D &= 24.32 \text{ mm} \\M_D &= 21.63 \text{ mm}\end{aligned}$$

$$\begin{aligned}E_D &= 24.32 + 1.48 \\&= 25.80 \text{ mm}\end{aligned}$$

$$\begin{aligned}P_D &= 25.80 - 21.63 \\&= 4.17 \text{ mm}\end{aligned}$$

$$S_D = 2.40 \text{ mm}$$

$$\begin{aligned}L_D &= 4.17 - 2.40 \\ \Leftrightarrow L_D &= 1.77 \text{ mm}\end{aligned}$$



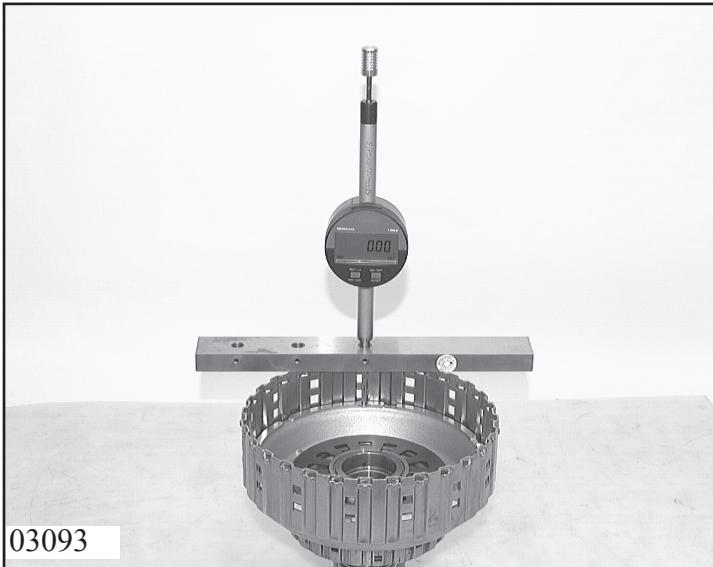

03093

1.4.3 Adjusting released clearance, clutch B (snap ring)

Determine installed space E_B for clutch B with measuring bar 5p01 000 330. To do this, place measuring bar 5p01 000 330 on the edge of the cylinder of clutch B. Place the measuring foot on the highest point of the disk contact face and set the dial gauge to "0".

Pull up the measuring sensor, insert it into the snap ring groove and press it against the upper edge of the groove.

Take the dial gauge reading $\Rightarrow W_B$

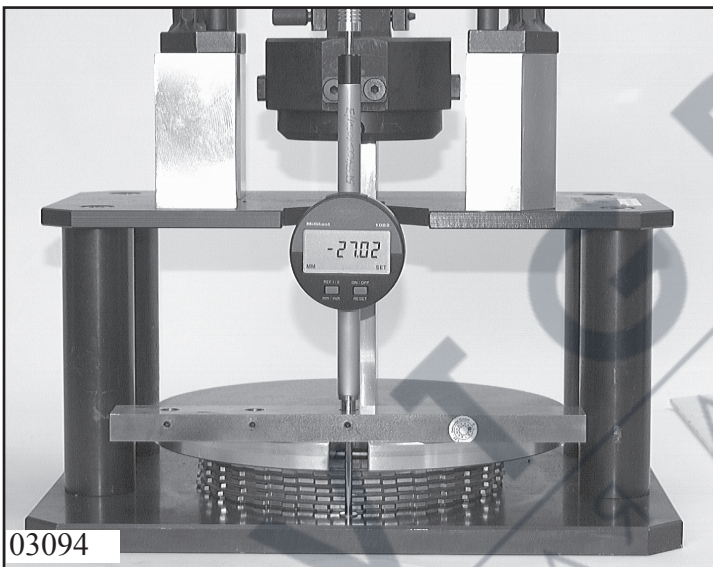

03094

Determine thickness M_B of the clutch B disk cluster as described in Chapter 1.4.0 "Measuring the disk clusters".

$\Rightarrow M_B$

Installed space E_C is obtained from measured value W_B plus foot thickness F . $\Rightarrow E_B$

Text value P_B is then obtained from installed space E_B minus M_B .

Value P_B should be between 3.01 – 4.61 mm. Test directive 1071 700 114
Version B

Use test gauge P_B to select snap ring S_B .

Calculation:

$$E_B = W_B + F$$

$$P_B = E_B - M_B$$

Released clearance L_B with 5 lined disks should be 1.42 – 1.71 mm.

Example (for 1.4.3):

$$F = 1.48 \text{ mm (foot thickness)}$$

$$W_B = 29.52 \text{ mm}$$

$$M_B = - 27.02 \text{ mm}$$

$$E_B = 29.52 + 1.48$$

$$= 31.00 \text{ mm}$$

$$P_B = 31.00 - 27.02$$

$$= 3.98 \text{ mm}$$

$$S_B = 2.30 \text{ mm}$$

$$L_B = 3.98 \text{ mm} - 2.40 \text{ mm}$$

$$\diamond L_B = 1.58 \text{ mm}$$



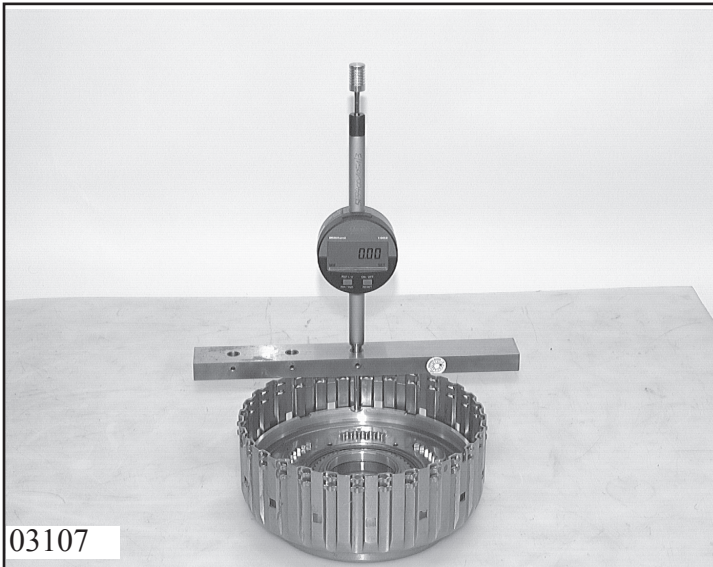

1.4.4 Adjusting released clearance, clutch A (snap ring)

Determine installed space E_A for clutch A with measuring bar 5p01 000 330. To do this, place measuring bar 5p01 000 330 on the edge of the cylinder of clutch A. Place the measuring foot on the highest point of the disk contact face of the piston and set the dial gauge to “0”. Pull the measuring sensor up, guide it into the lower snap ring groove and press it against the upper edge of the groove.

Take the dial gauge reading $\Rightarrow W_A$

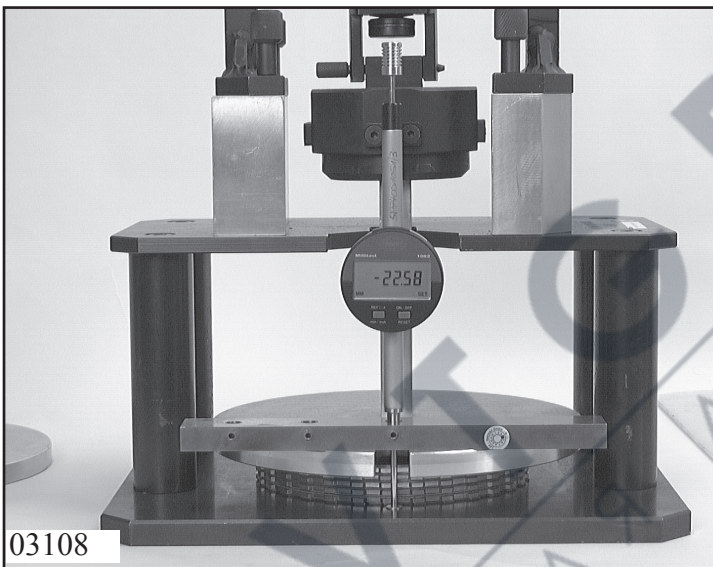

Determine thickness M_A of the clutch A disk cluster as described in **Chapter 1.4.0 “Measuring the disk clusters”**.

$\Rightarrow M_A$

Installed space E_A is obtained from measured value W_A plus foot thickness F . $\Rightarrow E_A$

Text value P_A is then obtained from installed space E_A minus M_A .

Value P_A should be between 3.51 – 4.71 mm. **Test directive 1071 700 063**
Version **B**

Use test gauge P_A to select snap ring S_A .

Calculation:

$$E_A = W_A + F$$

$$P_A = E_A - M_A$$

Release clearance L_A with 4 lined disks should be 1.52 – 1.81 mm.

Example (for 1.4.4):

$$F = 1.48 \text{ mm (foot thickness)}$$

$$W_A = 25.44 \text{ mm}$$

$$M_A = - 22.58 \text{ mm}$$

$$E_A = 25.44 + 1.48$$

$$= 26.92 \text{ mm}$$

$$P_A = 26.92 - 22.58$$

$$= 4.34 \text{ mm}$$

$$S_A = 2.60 \text{ mm}$$

$$L_A = 4.34 - 2.60$$

$$\varnothing L_A = 1.74 \text{ mm}$$



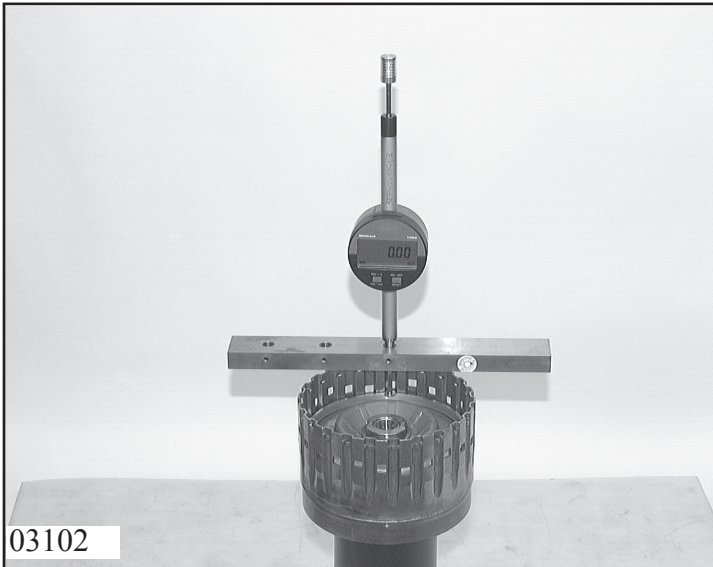

1.4.5 Release clearance, clutch E (snap ring)

Determine installed space E_E for clutch E with measuring bar 5p01 000 330. To do this, place measuring bar 5p01 000 330 on the edge of the cylinder of clutch E. Place the measuring foot on the highest point of the disk contact face on the piston, and set the dial gauge to "0". Pull up the measuring sensor, insert it into the snap ring groove and press it against the upper edge of the groove.

Take the reading at the dial gauge $\Rightarrow W_E$

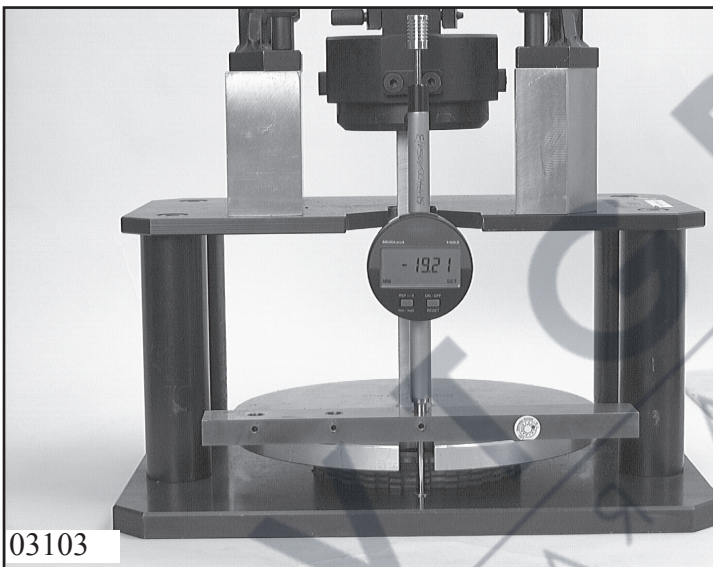

Determining the thickness M_E of the clutch E disk cluster as described in Chapter 1.4.0 "Measuring the disk clusters".

$\Rightarrow M_E$

Installed space E_E is obtained from measured value W_E plus foot thickness F . $\Rightarrow E_E$

Text value P_E is then obtained from installed space E_E minus M_E .

Value P_E should be between 3.43 – 4.57 mm. Test directive 1071 700 058
Version C.

Use test gauge P_E to select snap ring S_E .

Calculation:

$$E_E = W_E + F$$

$$P_E = E_E - M_E$$

Released clearance L_E should be 1.38 – 1.67 mm with 4 lined disks.

Example (for 1.4.5):

$$F = 1.48 \text{ mm (foot thickness)}$$

$$W_E = 21.58 \text{ mm}$$

$$M_E = 19.21 \text{ mm}$$

$$E_E = 21.58 + 1.48$$

$$= 23.06 \text{ mm}$$

$$P_E = 23.06 - 19.21$$

$$= 3.85 \text{ mm}$$

$$S_E = 2.20 \text{ mm}$$

$$L_E = 3.85 - 2.20$$

$$\varnothing L_E = 1.65 \text{ mm}$$



1.4.6 Output side play (washer)

Screw the measuring stand into the hole provided in the transmission casing and place the dial gauge on the output shaft. Press on the flange and set the dial gauge to "0".

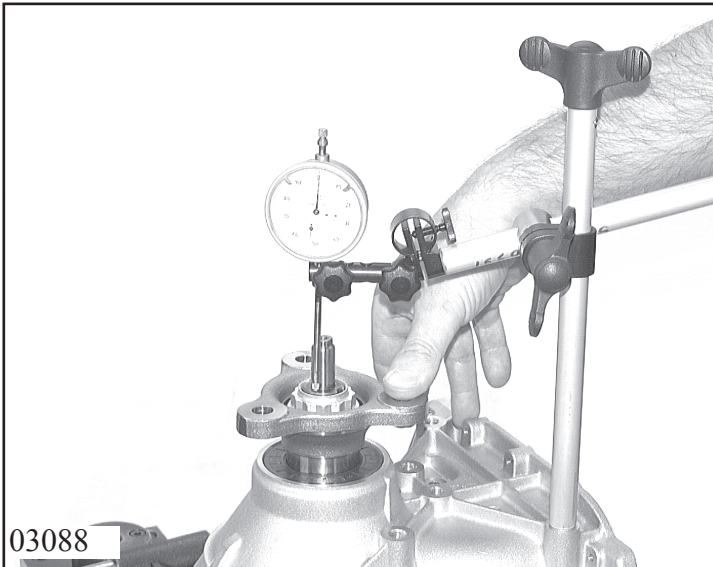

Pull on the flange and read off measurement A. Select a thicker or thinner washer if dimension A is beyond tolerance C.

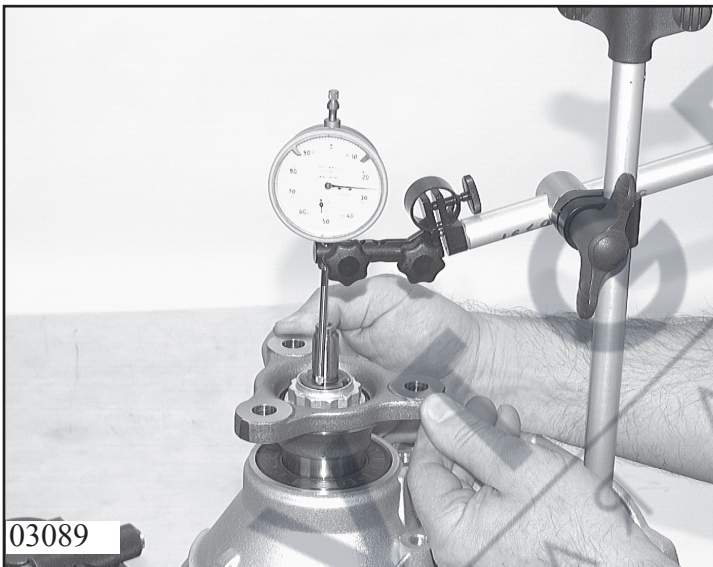

Example: (for 1.4.6)

A = 0.15 mm

C = 0.15 to 0.35 mm

◇ **The washer is correct.**

1.4.7 Input-side play (washer)

Tighten the oil supply in the casing at the four opposed machine screws 10.080.

(For tightening torque, see Chapter 1.5)

Preconditions:

A shim washer 10.090 (thickness = 2,6 mm, the thinnest acc. to WTB) is in position.

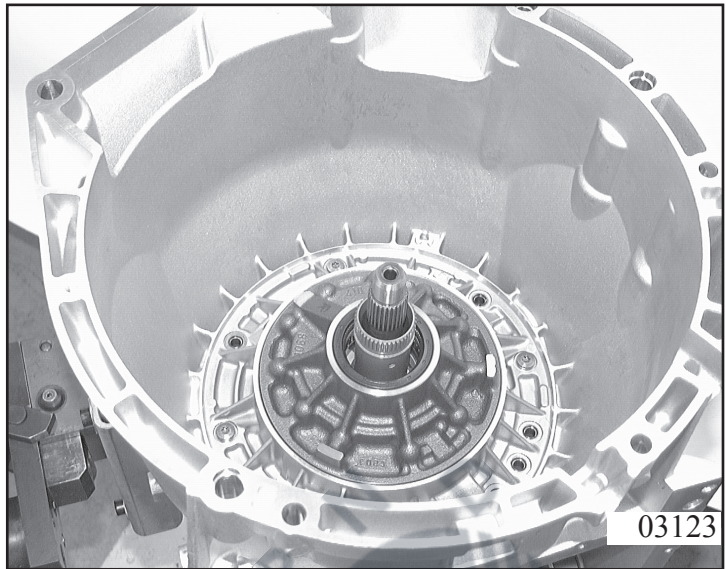

Press measuring fixture 5p01 002 379 over the input shaft splines and clamp into position about 2 mm above the impeller with the retaining screw.

Set the dial gauge to "0".

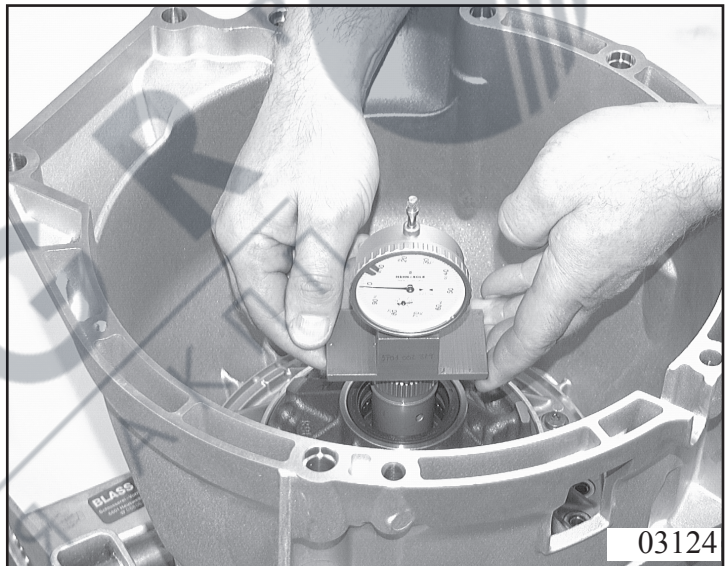

Determine endplay by pushing and pulling at the handle (repeat the measurement several times).

If endplay = 0.2 – 0.4 mm at a force of 200N (when dry, according to **test directive 1068 700 051**)

Install a thicker or thinner washer 02.260 as appropriate if the endplay is not as stated.

Finally, check endplay again.

(M Type only)

1.4.8 Switch setting (detent spring)

Using a suitable tool or by hand, set the detent disk to position N (Neutral).

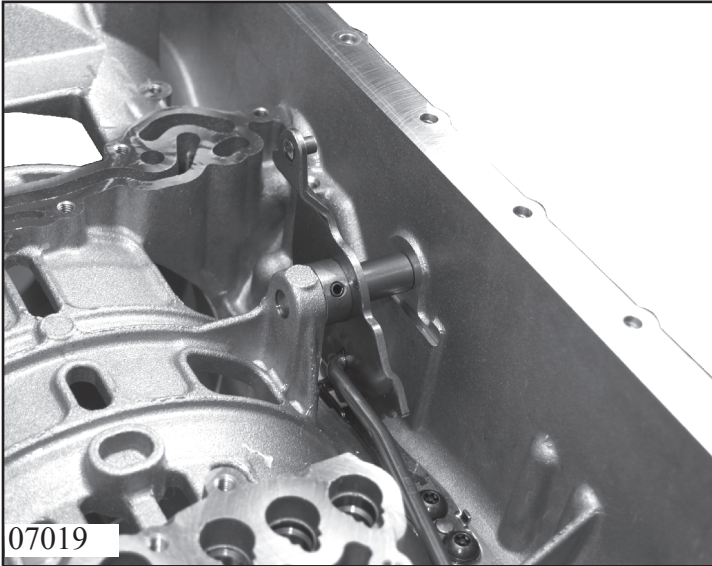

Detent spring with centering device
Align 5x46 002 292 and in this position,
tighten the detent spring.
Tighten the screw on the output side first.

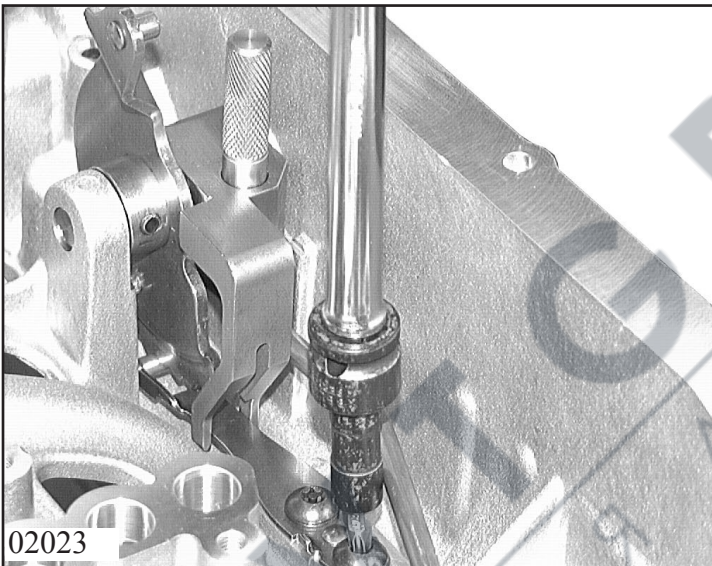

(For tightening torque, see **Chapter 1.5**)

After this, use auxiliary tool 5w04 000
583 to turn farther by the amount of
angular offset.
Remove the centering device.
Shift the selector shaft through all
positions, then remove.

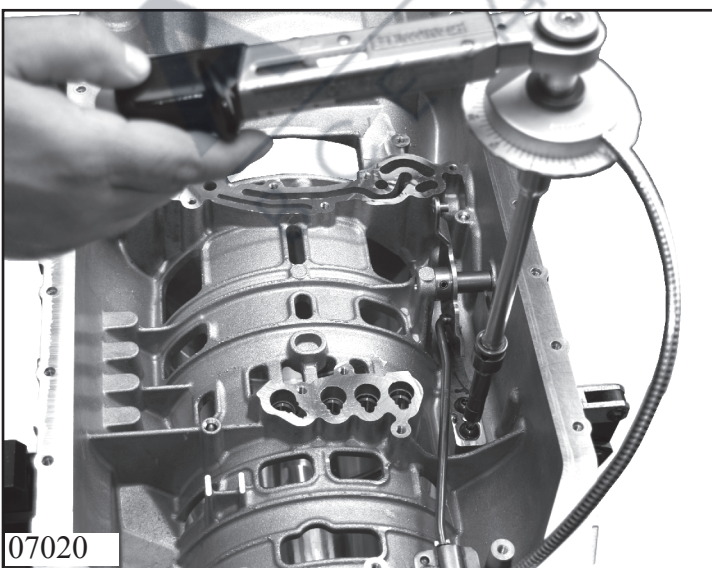

(For tightening torque, see **Chapter 1.5**)



1.5 Tightening torques

No.	Designation	Part List-Item-No.	Wrench size No.	Page	Tightening torque [Nm]
1	Screw plug (transmission housing)	01.100	Hexagonal socket Size = 5 mm	3.1/2	12 Nm (±1.2 Nm)
2	Machine screw (detent spring M type)	06.100	TORX - TX 27 H	1.4/15 3.1/3	4 Nm ± 3% + (27° ± 2%)
3	Machine screw (guide plate)	24.120	TORX - TX 27	3.1/4	10 Nm (±1.0 Nm)
4	Screw plug M12x1.5 (torsion spring)	24.020	Hexagonal socket Size = 6 mm	3.1/4	23 Nm (±2.3 Nm)
5	Hex bolt (lever)	06.190	Hex Size = 13 mm	3.1/5	9.5 Nm (±1.0 Nm)
6	Machine screw (emergency release, E type)	06.210	TORX - TX 27	3.1/5	10 Nm (±1.0 Nm)
7	Castellated nut (output <u>without</u> Helium-WDR) (output <u>with</u> Helium-WDR)	14.160	Socket wrench 5X46 002 456 5X46 002 456	3.2/3	80 Nm (±8.0 Nm) 60 Nm (±6.0 Nm)
8	Machine screw (stator shaft/intermediate plate)	10.040/150	TORX - TX 27	3.6/3	15 Nm (±1.5 Nm)
9	Machine screw (stator shaft/centering plate)	10.050	TORX - TX 27	3.6/3	15 Nm (±1.5 Nm)
10	Countersunk screw (intermediate plate/pump)	10.080	TORX - TX 27	1.4/14 3.6/4	10 Nm (±1.0 Nm)
11	Machine screw (Mechatronic)	27.450 27.500	TORX - TX 30	1.3/1 3.7/3	8 Nm (±0,8 Nm)
12	Machine screw (oil pan)	03.020	TORX - TX 27	3.7/4	10 Nm (±1,0 Nm)
13	Screw plug M18x1.5 (transmission casing)	01.140	Hexagonal socket Size = 8 mm	3.7/4	35 Nm (±3,5 Nm)

No.	Designation	Part List- Item-No.	Wrench size No.	Page	Tightening torque [Nm]
14	Screw plug M16x1.5 (oil pan)	03.010/030	Hexagonal socket Size = 10 mm	3.7/5	9 Nm (-1.0 Nm)
15	Hex bolt M8x45 (converter retaining bracket)	97.020	Size = 13 mm	3.7/5	15 Nm (±1.5 Nm)
16	Hex bolt M10x16 (converter retaining bracket)	97.030	Size = 17 mm	3.7/5	15 Nm (±1.5 Nm)



1.6 Transmission test (test bench)

The following points must be checked:

Correct oil level

Proper oil level; observe the vehicle manufacturer's specifications and Part List.

Oil level too low

This can result in:

Engine over-revving or no power flow in curves or when starting from a stop

Valve chatter due to air pockets in the oil

General malfunctions

Among other things, burned clutches can be the result.

Oil level too high

Danger of loss due to splashing, formation of foam, strong increases in temperature at high road speeds. Loss of oil via breather; among other things, burned clutches and shifting problems can result.

Proper engine settings

Correct idle speed; follow specifications from vehicle manufacturer.

Power flow, forward and reverse



Correct adjustment of selector linkage or control cable; observe the vehicle manufacturer's specifications.



Cooler-bypass or cooler connection on the test bench

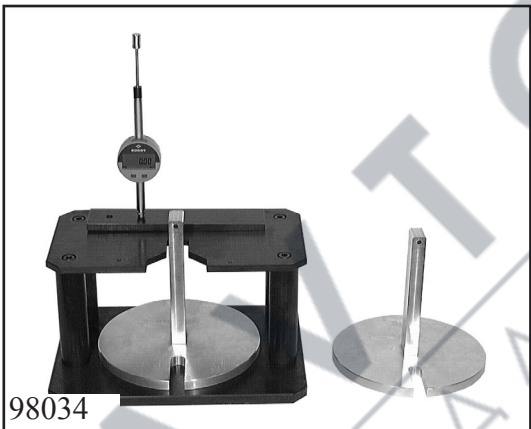

Do not overheat transmission, maximum 120° C.



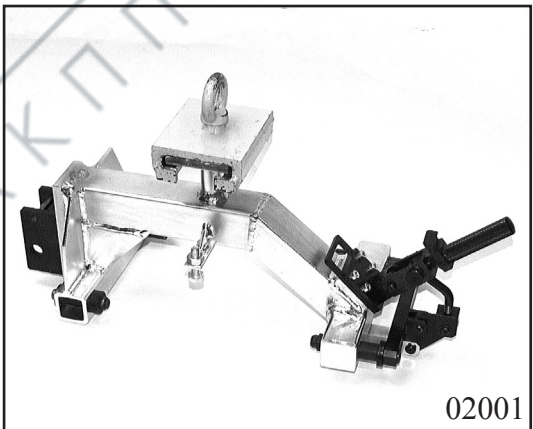



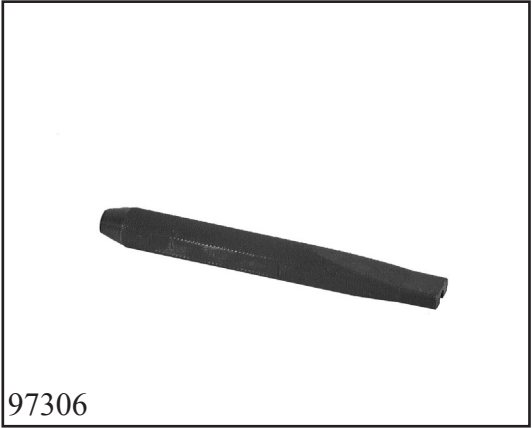

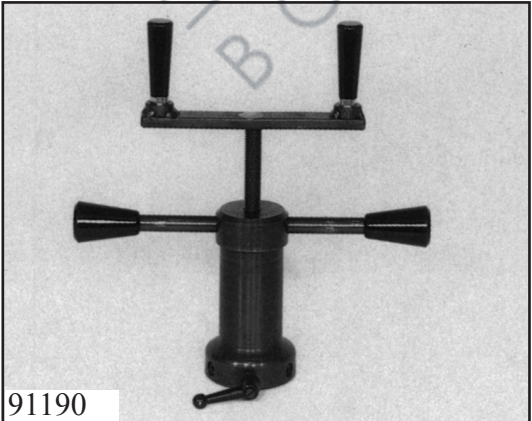
1.7 Special tools

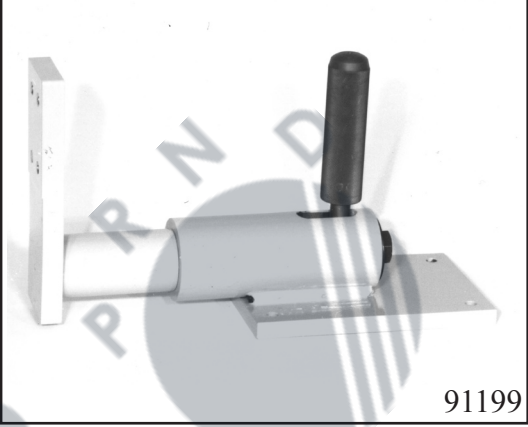

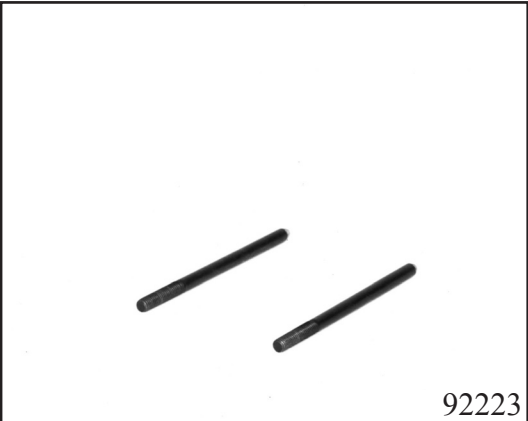
OBJECT	Order-No. / Application	Remarks
<p style="text-align: center;">1</p>  <p>98008</p>	<p>5p01 000 329 Strain gauge</p>	<p>identical</p> <p>4 HP 20 5 HP 19 5 HP 19 FL/A 5 HP 24 5 HP 24 A 6 HP 26 6 HP 19</p>
<p style="text-align: center;">2</p>  <p>98034</p>	<p>5p01 000 330 Clutch play measuring fixture</p> <p>(Measuring plate: - short neck > 20 mm - long neck < 20 mm Disk cluster thickness)</p>	<p>identical</p> <p>4 HP 20 5 HP 19 5 HP 19 FL/A 5 HP 24 5 HP 24 A 6 HP 26 6 HP 19</p>
<p style="text-align: center;">3</p>  <p>97301</p>	<p>5p01 001 458 Preload adjusting fixture</p>	<p>identical</p> <p>4 HP 18 Q 4 HP 20 5 HP 19 5 HP 19 FL/A 5 HP 24 5 HP 24 A 6 HP 26 6 HP 19</p>

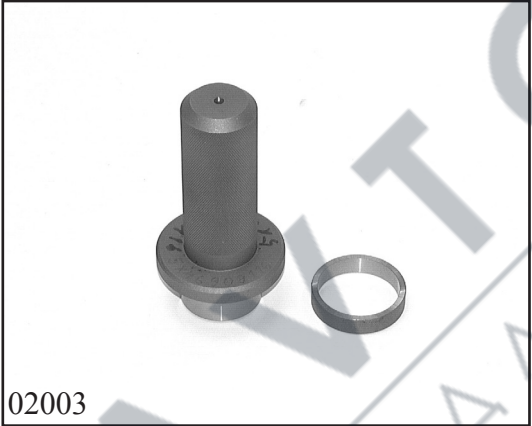

Remarks	Order-No. / Application	OBJECT
identical 4 HP 20 5 HP 19 6 HP 26 6 HP 26 A 61 6 HP 19 6 HP 19 A 6 HP 32 6 HP 32 A	5p01 002 379 Endplay measuring fixture Input shaft	4  02025
identical 5 HP 18 5 HP 19 6 HP 19	5x46 000 620 Transmission retaining hoop	5  02001
identical 6 HP 19	5x46 909 539 Assembly mandrel, brake D	6  03140

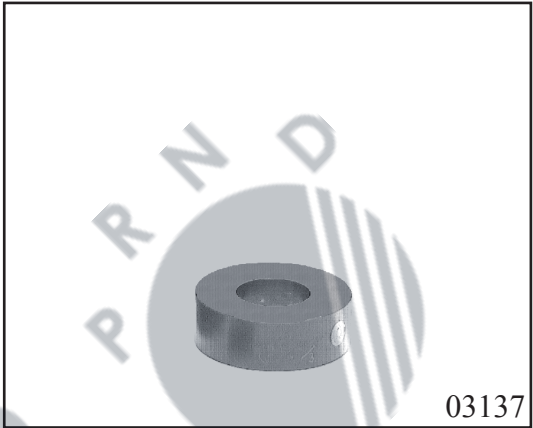

OBJECT	Order-No. / Application	Remarks
<p style="text-align: center;">7</p>  <p>97306</p>	<p>5x46 000 291 Locking pin drive-in arbor</p>	<p>identical all Gearboxes</p>
<p style="text-align: center;">8</p>  <p>98135</p>	<p>5x46 000 306 Sleeve for testing pump torque</p>	<p>identical all Gearboxes</p>
<p style="text-align: center;">9</p>  <p>91190</p>	<p>5x46 002 319 Detaching/installing fixture for oil supply, complete</p>	<p>identical 5 HP 19 5 HP 19 FL/A 6 HP 19 6 HP 19A</p>

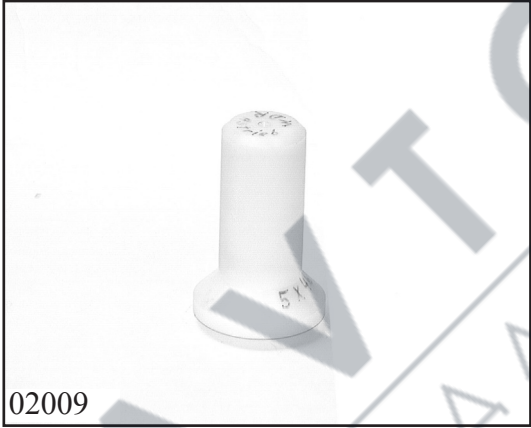

Remarks	Order-No. / Application	OBJECT
identical all Gearboxes	5x46 000 763 Workbench holder	10  91199
identical all Gearboxes	5x46 000 917 Mounting fixture	11  92214
identical 5 HP 19 5 HP 19 FL/A 5 HP 24 5 HP 24 A 6 HP 26 6 HP 26 A 61 6 HP 19 6 HP 19 A 6 HP 32 6 HP 32 A	5x46 001 007 2 locating pins	12  92223

OBJECT	Order-No. / Application	Remarks
<p style="text-align: center;">13</p> 	<p>5x46 002 456 Nut wrench</p>	<p>identical</p> <p>6 HP 26 6 HP 19</p>
<p style="text-align: center;">14</p> 	<p>5x46 002 558 Needle-roller drive-in arbor + pump shaft sealing ring</p>	<p>identical</p> <p>6 HP 26 6 HP 26 A 61 6 HP 19 6 HP 19 A 6 HP 32 6 HP 32 A</p>
<p style="text-align: center;">15</p> 	<p>5x46 909 346 Drive-in arbor for output-side ball bearing</p>	<p>identical</p> <p>6 HP 19</p>

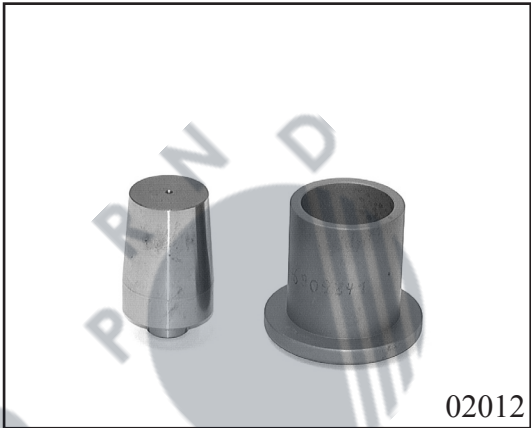
Remarks	Order-No. / Application	OBJECT
<p>identical 6 HP 19</p>	<p>5x46 909 347 Supporting ring</p>	<p>16</p>  <p>03137</p>
<p>identical 6 HP 19 6 HP 19 A</p>	<p>5x46 909 345 Drive-in arbor for shaft sealing ring</p>	<p>17</p>  <p>02006</p>
<p>identical 6 HP 19 6 HP 19 A</p>	<p>5x46 909 247 Clutch assembly hoop, A, C, E</p>	<p>18</p>  <p>03139</p>

OBJECT	Order-No. / Application	Remarks
<p style="text-align: center;">19</p>  <p>03138</p>	<p>5x46 909 248 Clutch assembly hoop B</p>	<p>identical</p> <p>6 HP 19 6 HP 19 A</p>
<p style="text-align: center;">20</p>  <p>02009</p>	<p>5x46 002 567 Drive-in arbor, output-side shaft sealing ring</p>	<p>identical</p> <p>6 HP 26 6 HP 19</p>
<p style="text-align: center;">21</p>  <p>97312</p>	<p>5x95 000 410 Puller handle</p>	<p>identical</p> <p>5 HP 24 5 HP 24 A 6 HP 26 6 HP 26 A 61 6 HP 32 6 HP 19 6 HP 19 A</p>

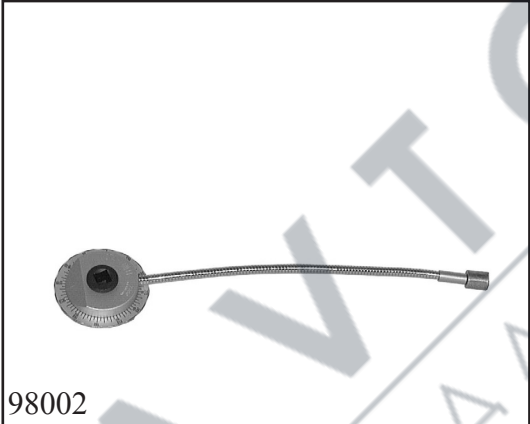
Remarks	Order-No. / Application	OBJECT
identical 6 HP 19 6 HP 19 A	5x46 003 343 Snap ring assembly aid, clutch E	22  02012
identical all Gearboxes	5x56 000 090 2 converter puller handles	23  76046
identical 5 HP 24 5 HP 24 A 6 HP 26 6 HP 26 A 61 6 HP 32 6 HP 19 6 HP 19 A	5x46 001 930 Drive-in tool for snap ring in groove in casing	24  97315

OBJECT	Order-No. / Application	Remarks
<p data-bbox="405 409 488 443">25, 26</p>  <p data-bbox="185 862 268 891">02036</p>	<p data-bbox="767 427 1214 533">5x46 002 849 Helium shaft sealing ring drive-in tool</p> <p data-bbox="767 577 1198 723">5x46 012 696 Helium shaft sealing ring installation aid BMW</p>	<p data-bbox="1262 427 1374 456">identical</p> <p data-bbox="1270 501 1374 568">6 HP 26 6 HP 19</p>
<p data-bbox="427 969 464 1003">27</p>  <p data-bbox="185 1422 268 1451">98002</p>	<p data-bbox="767 987 943 1021"><i>(M Type only)</i></p> <p data-bbox="767 1066 1214 1171">5w04 000 583 Torsional offset assembly measuring fixture Detent spring</p>	<p data-bbox="1262 987 1374 1016">identical</p> <p data-bbox="1270 1066 1437 1245">6 HP 26 6 HP 26 A 61 6 HP 32 6 HP 19 6 HP 19 A</p>
<p data-bbox="427 1529 464 1563">28</p>  <p data-bbox="185 1982 268 2011">02026</p>	<p data-bbox="767 1552 1150 1619">5x46 002 292 Detent spring centering device</p>	<p data-bbox="1262 1552 1374 1581">identical</p> <p data-bbox="1270 1626 1437 1805">6 HP 26 6 HP 26 A 61 6 HP 32 6 HP 19 6 HP 19 A</p>



1.8 Oilflow chart (Position N) (E - type)

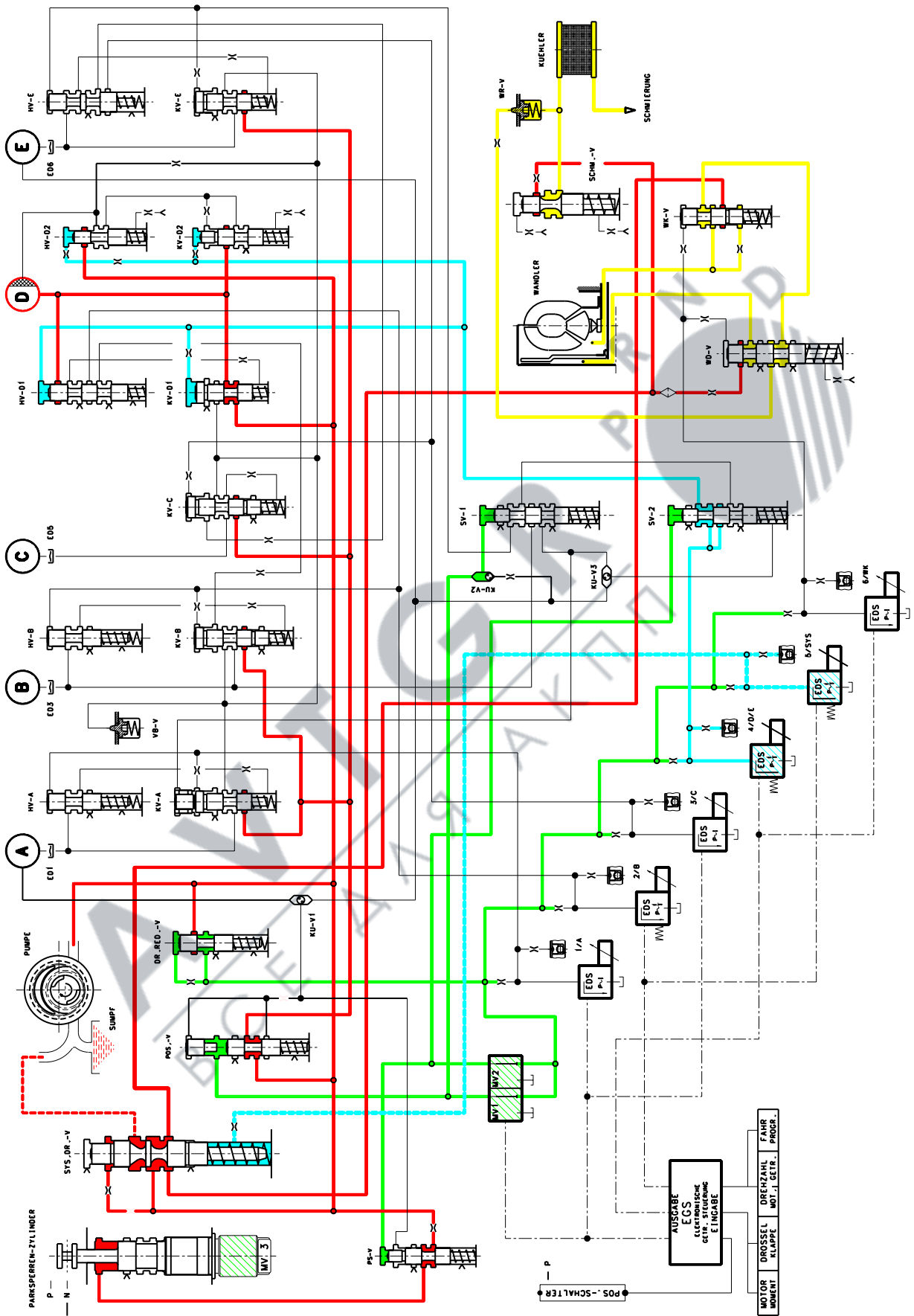

(M - type)

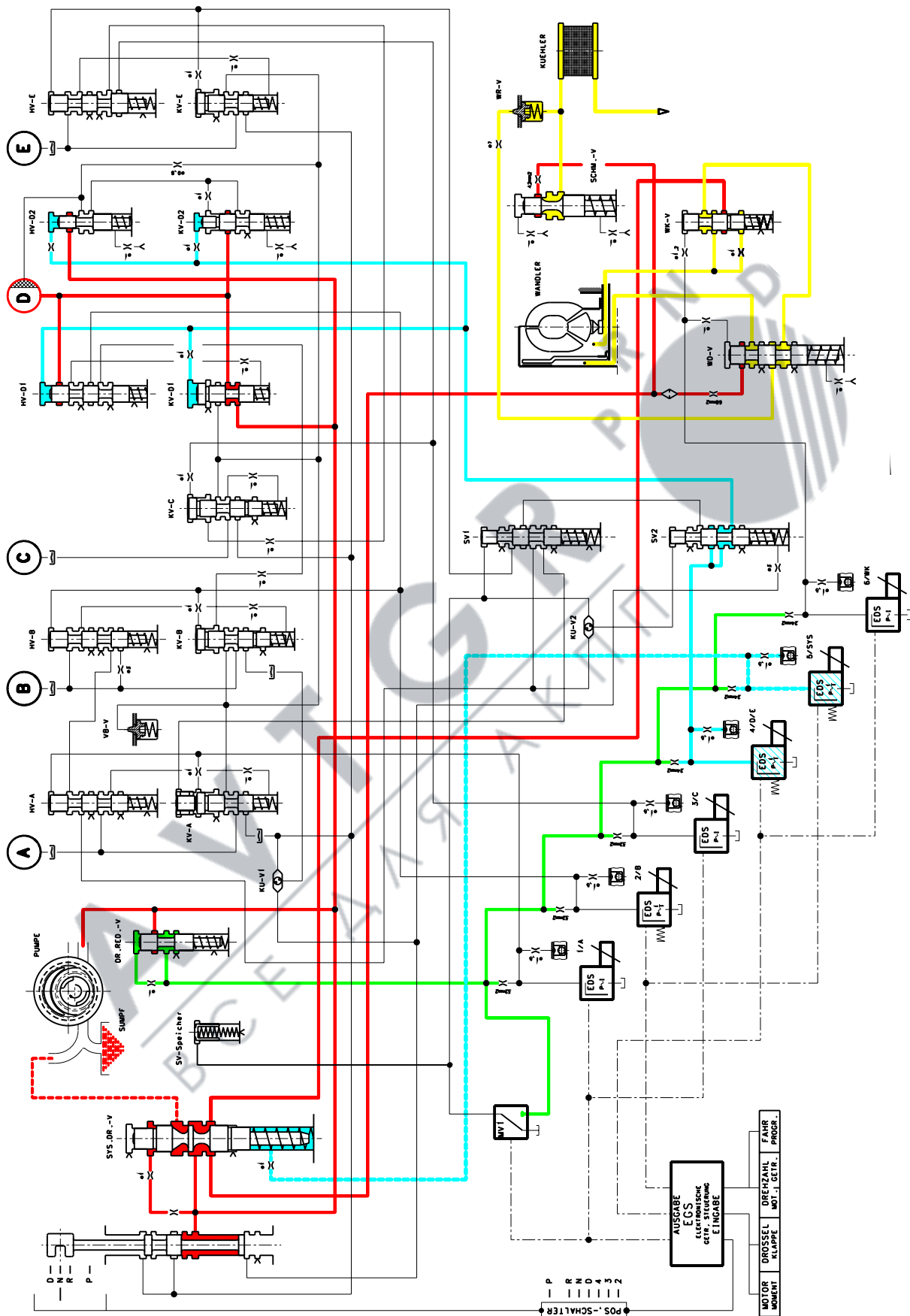

2. Disassembly

2.1 Disassembly of transmission according to component groups

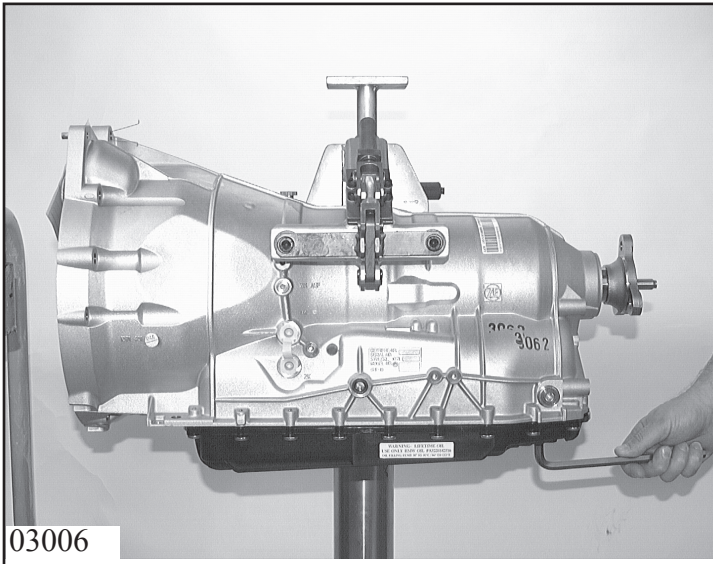

Clamp the transmission into the retaining hoop 5x46 000 620 and secure it on the assembly truck or if necessary in work-bench holder 5x46 000 763.

Unscrew and remove the oil drain/filler plug and allow the oil to drain out.

Wrench size

Oil drain plug = 10 mm Allen screw

Oil filler plug = 8 mm Allen screw

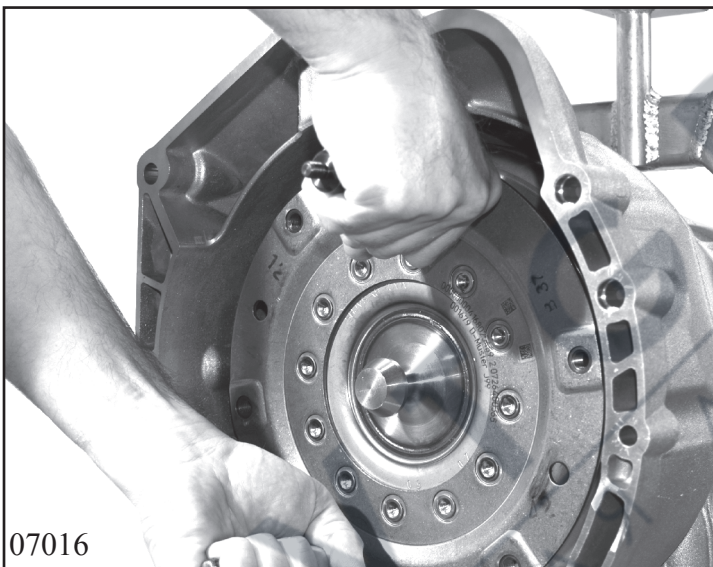

Remove the converter holding bracket and take out the converter, holding it by the two converter puller handles 5x56 000 090.

(Wrench size = 17 mm)

Warning!

Oil will escape.

Do not damage the converter bearings and the pump shaft sealing ring.

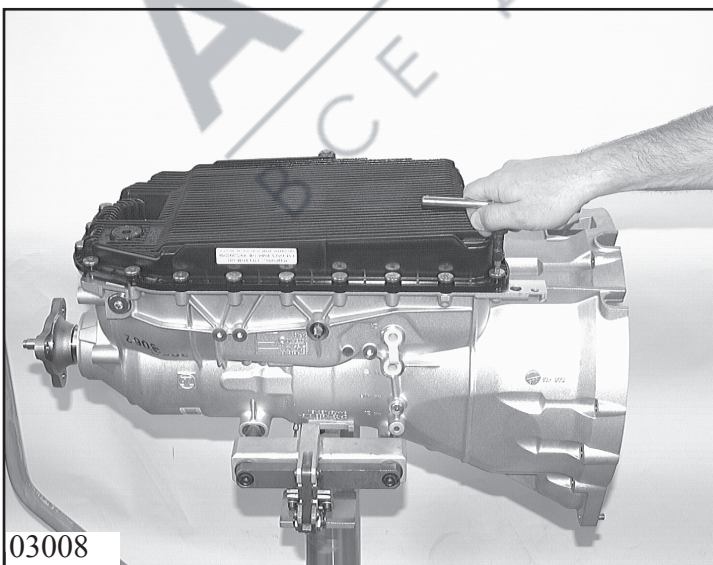

Turn the transmission by 180 degrees. Unscrew the 24 machine screws holding the oil pan, lift it off and pull off the O-ring seal and gasket.

(Wrench size = Torx TX 40)

Note:

We recommend exchanging the complete oil pan.

Pull the cap for protection in transit off the wiring harness socket and release the retaining clip.
Pull the socket out of the casing by hand.

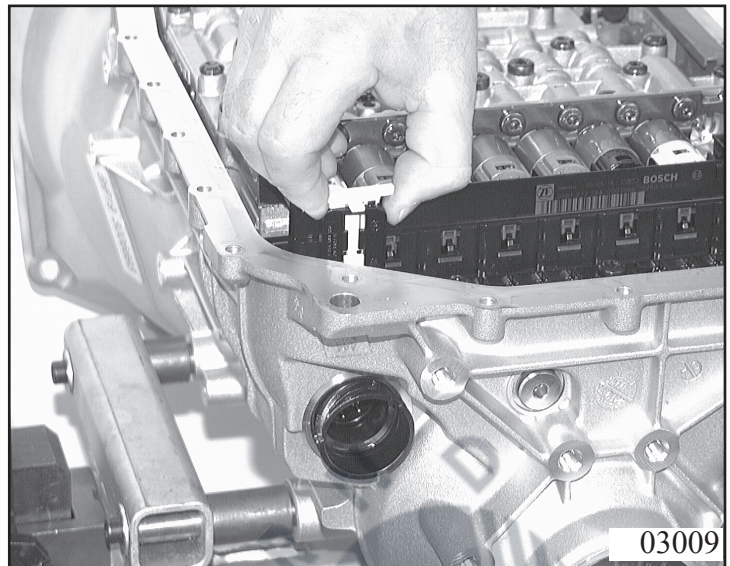

Unscrew and remove the **large-headed** screws (M6) and lift off the complete Mechatronic assembly.

(Wrench size = Torx TX 40)

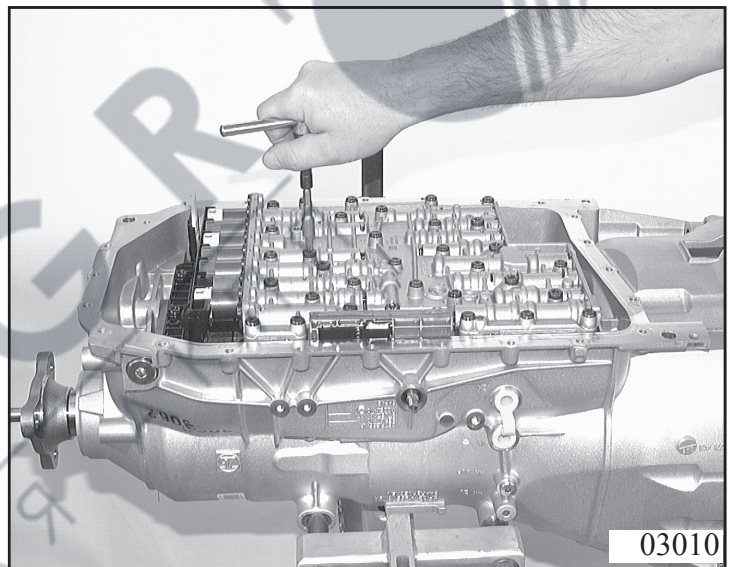

Use puller handle 5x95 000 410 to pull the 4 sealing sleeves out of the transmission casing.

Take the sealing sleeve out of the transmission casing.

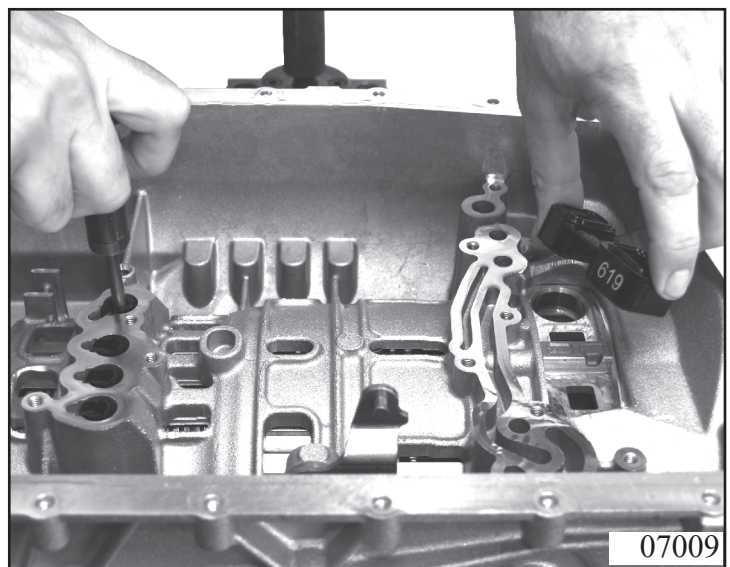

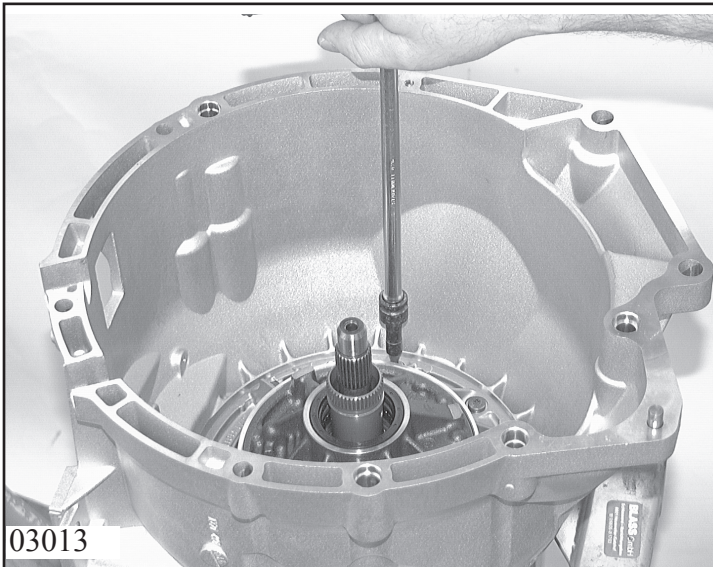

Turn the transmission by 90 degrees.
Remove the complete oil supply system
by unscrewing the 11 torx screws and
taking them out complete with the Usit
rings.

(Wrench size = Torx TX 27)

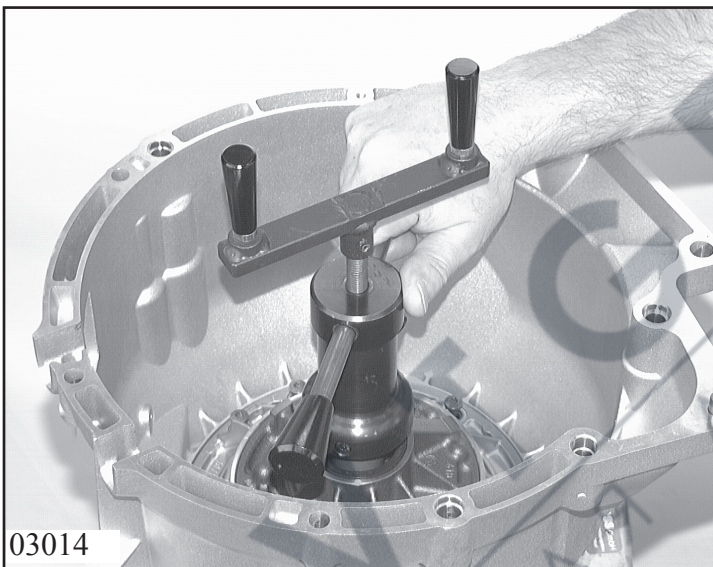

Press out the oil supply unit with lifter
5x46 002 319 and lift it off.

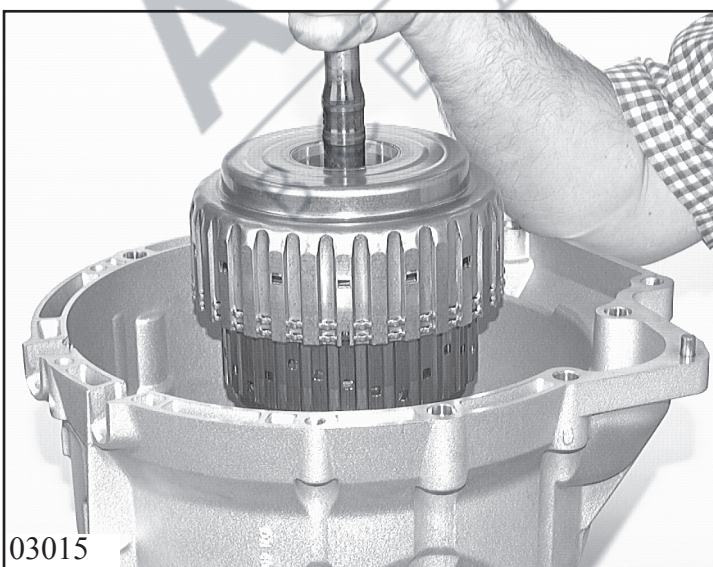

Take out the shim washer.
Remove the turret (input with clutches A
and E).
Lift out the complete assembly by hand.
Place the turret in mounting 5x46 000
917.

Take out clutch B by hand.

Note:

The angle disc can detach on the underside from clutch B during demounting. In this case remove the angle disc from the transmission housing.



Turn the transmission by 90 degrees and unscrew the 12-sided nut with wrench 5x46 002 456. Pull off the output flange.

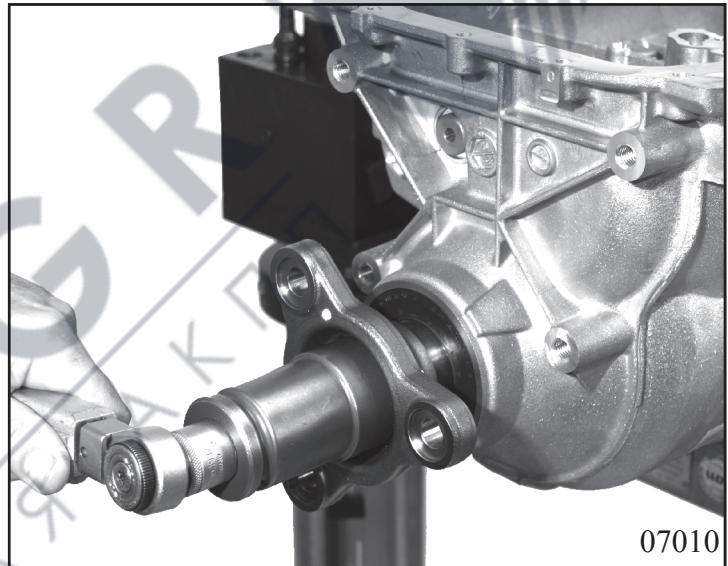

Turn the transmission by 90 degrees and lever out the snap ring from the casing with a suitable screwdriver or take it out with snap ring pliers. Lift out clutch CD with tool 5x46 004 182.

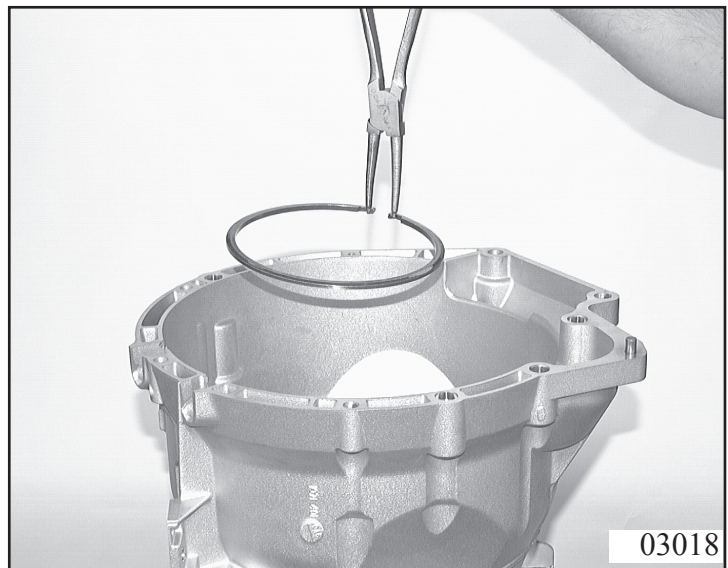

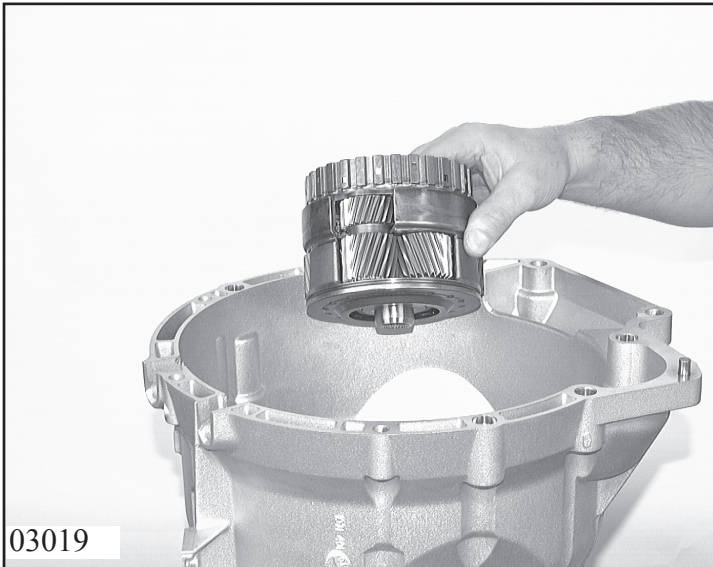

Remove sun wheel 2 with angle plate.
Take out the planet wheel carrier.

03019

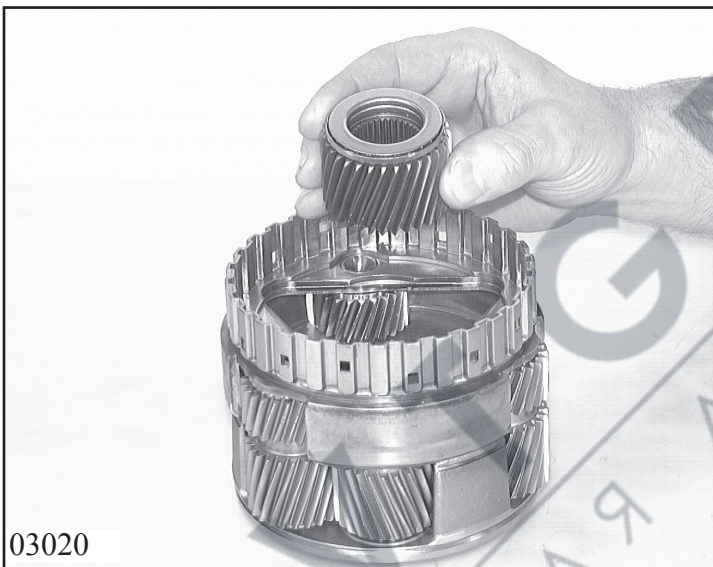

Using a suitable tool, separate the sun wheel from the bearing in the planet wheel carrier; take another sun wheel 3 out of the planet wheel carrier and unclip the bearing from sun wheel 3. Remove the bearing from the planet wheel carrier.

03020

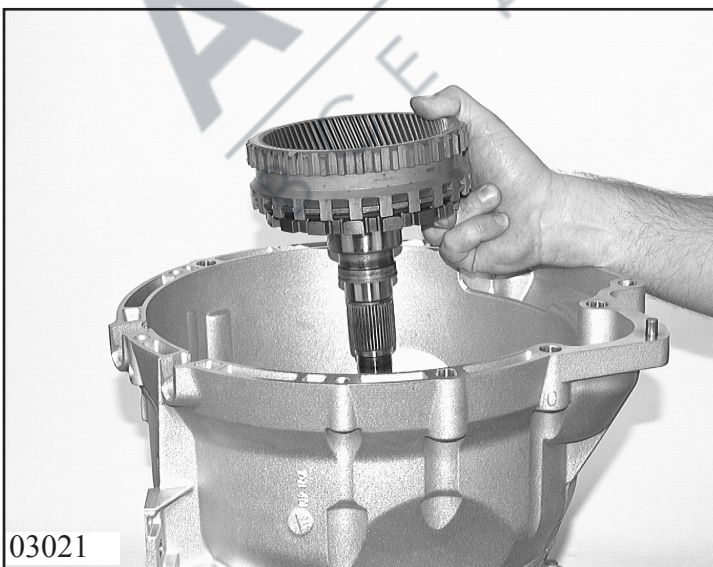

Take out the ring gear with output shaft.
Unclip the bearing from the planet wheel carrier hub.
Working from the rear, remove the shim washer for output-side endplay and the reversing washer.

03021



Disassembly

2.2 Turret (with clutches A and E)

Place the turret with the input shaft in fixture 5x46 000 917.
Take out the snap ring and remove inner disk carrier B.

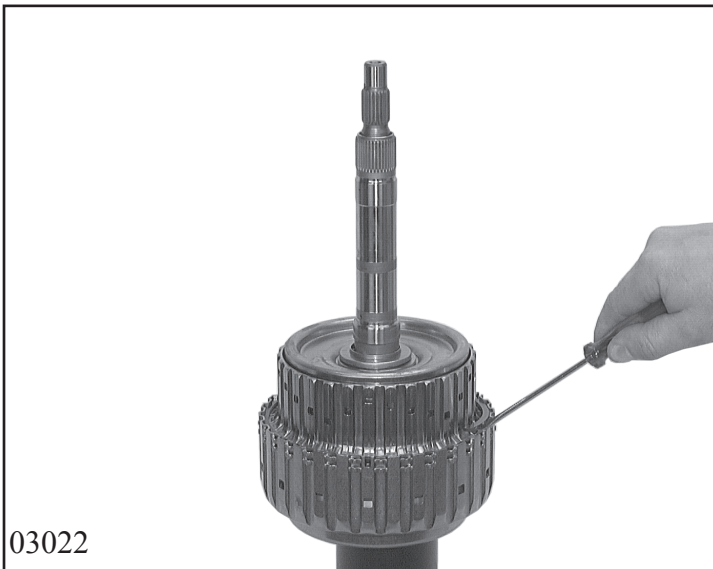

Take out inner disk carrier A and lever the needle roller thrust bearing out of the intermediate shaft, using a long scriber as a tool.

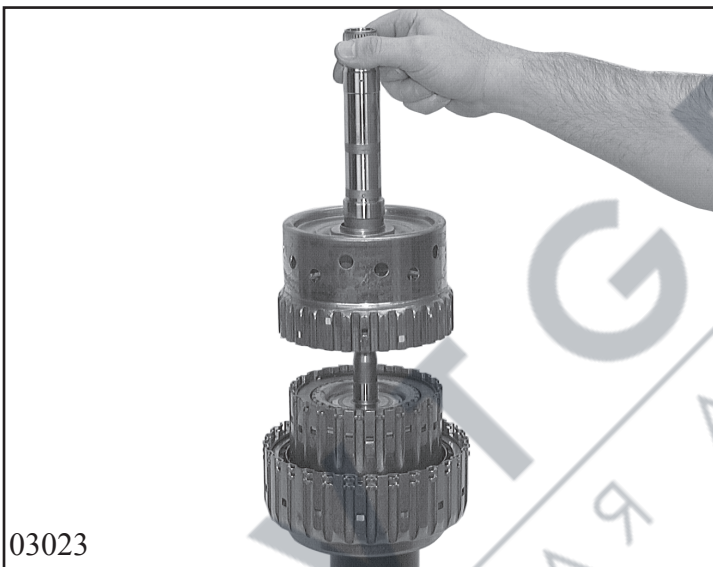

Lift off the intermediate shaft with inner disk carrier B. Lever out the needle roller thrust bearing.

Turn the complete unit by 180 degrees and insert it in the mount again.

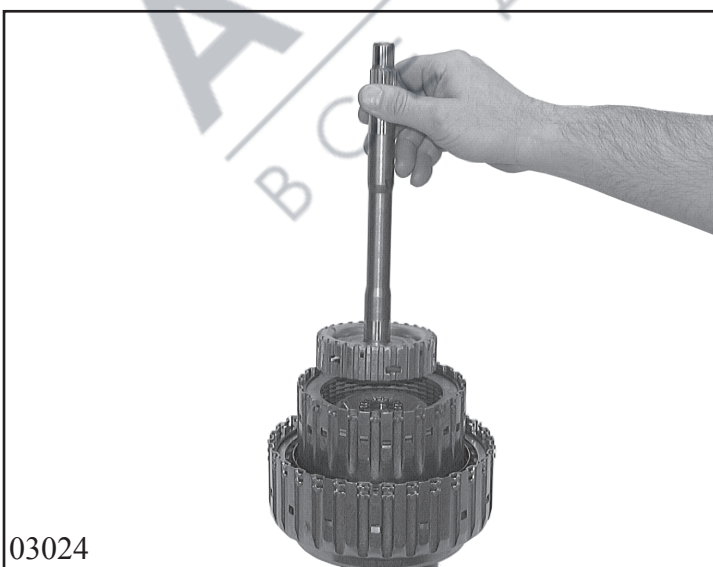

Pull of clutch A from clutch E / input shaft.

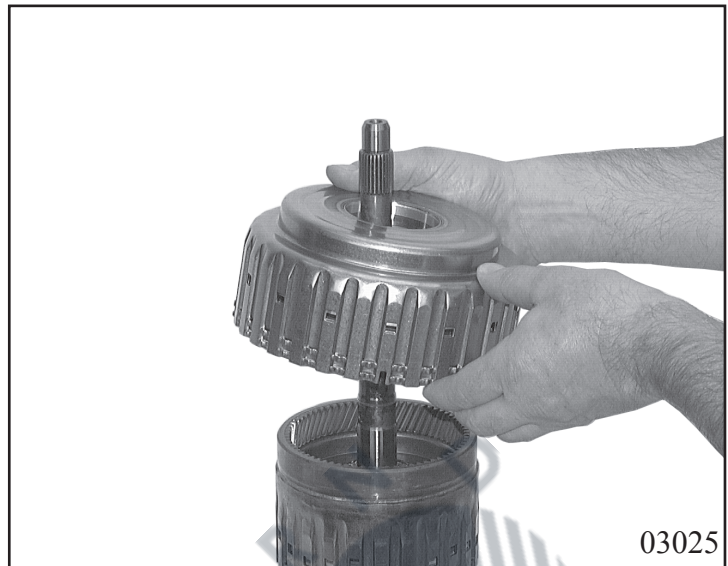

Caution:
Input shaft is splined to clutch E.

Take out the snap ring at clutch A and take out the complete set of disks.

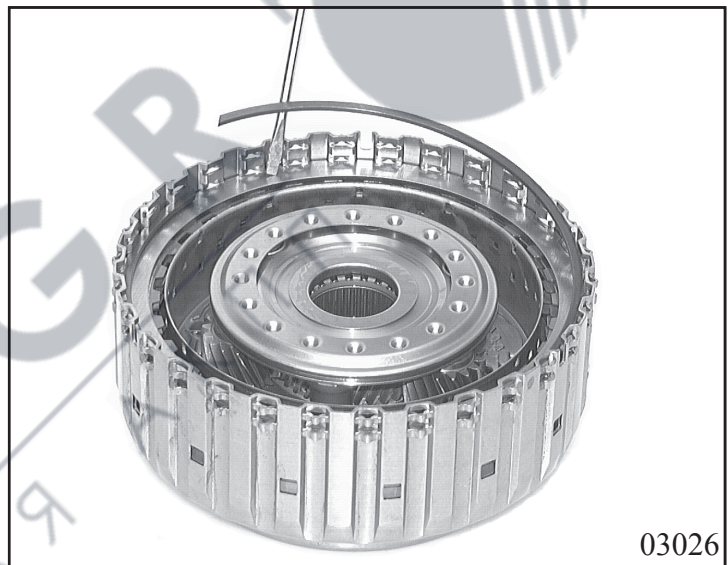

Bend up the lugs on the oilpan trap plate, turn the oil trap clockwise and take it out. Remove the sun wheel from the planet wheel carrier and lever out the needle roller thrust bearing cage.

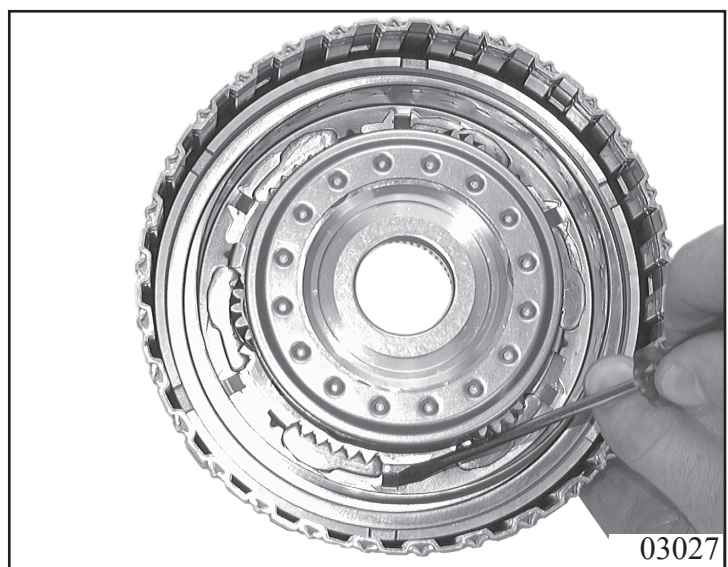

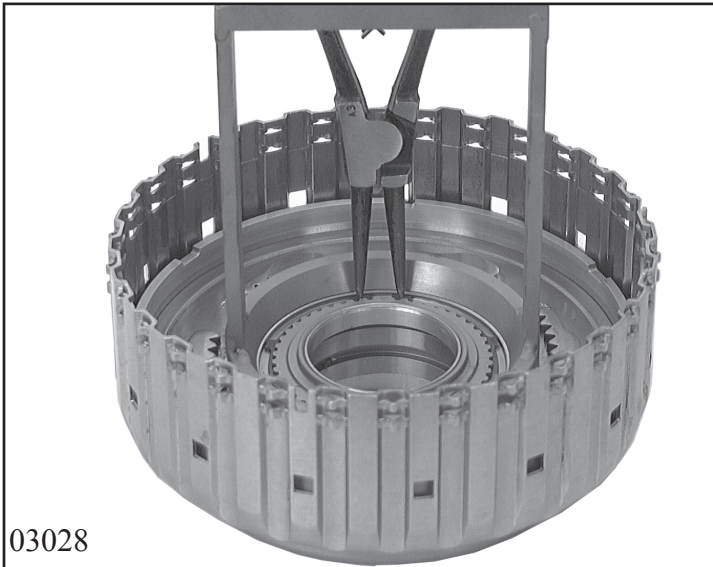

Using assembly hoop 5x46 909 247, press the cup spring down in the arbor press and remove the snap ring, using suitable pliers.

03028

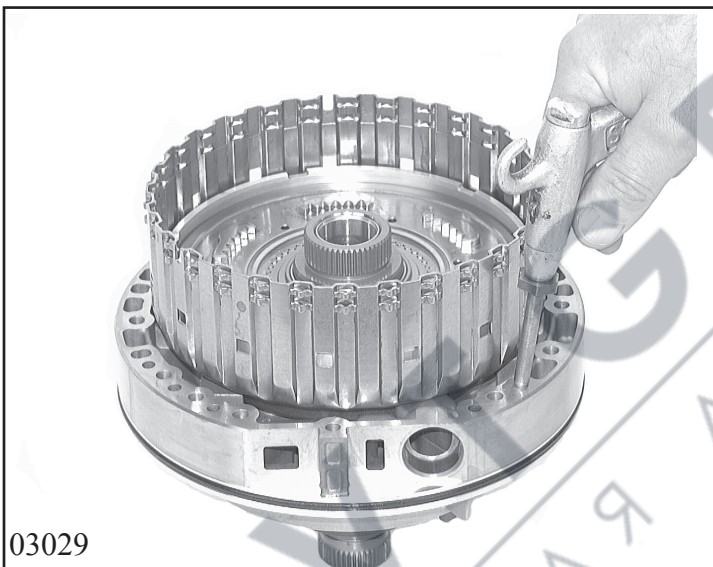

Mount cylinder A on the oil supply unit and force the complete cluster out with compressed air. Take out the planet wheel carrier and cup spring. Take out the baffle plate and pull the prof. seal ring. Take out the piston and pull 1 O-ring seal and 1 prof. seal ring off piston A. Lift cylinder A away from the oil supply unit.

03029

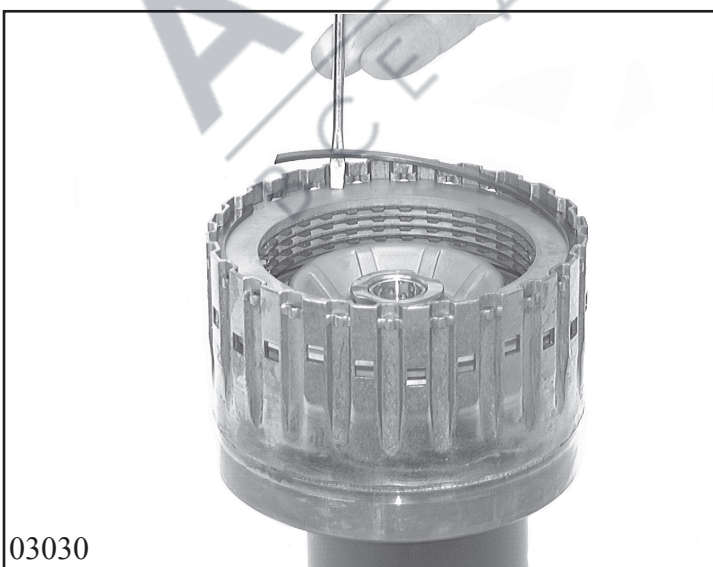

Take out the snap ring for clutch E and remove the complete clutch E disk set.

03030

Using assembly hoop 5x46 909 247, press the retaining washer down and remove the snap ring with suitable pliers. Remove the bracket and retaining washer and cup spring and pull the O-ring seal off the retaining washer.

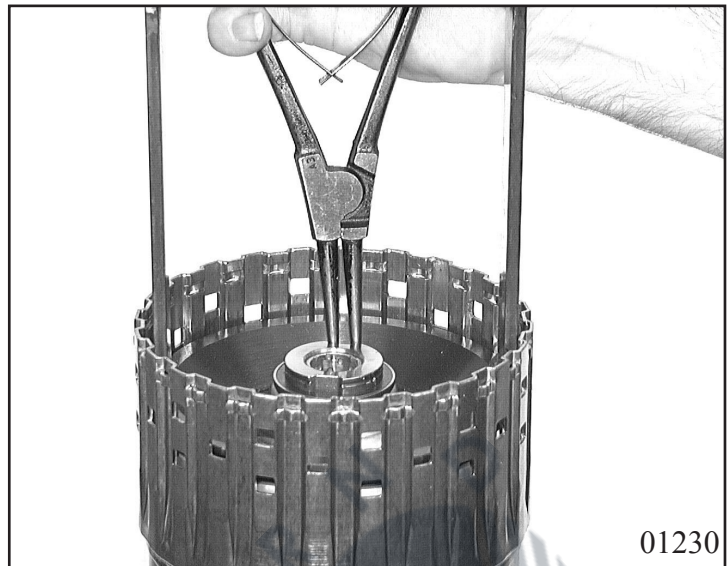

Plug one of the two oil feed holes and force piston E out with compressed air. Pull off the two O-ring seals.



Pull the three rectangular-section rings and one o-ring off the input shaft.



Note:
Unclip and remove the needle roller bearing if this is faulty.

2.3 Oil supply

Place the complete oil supply unit on a suitable working surface. Pull the 2 rectangular-section rings off the stator shaft.

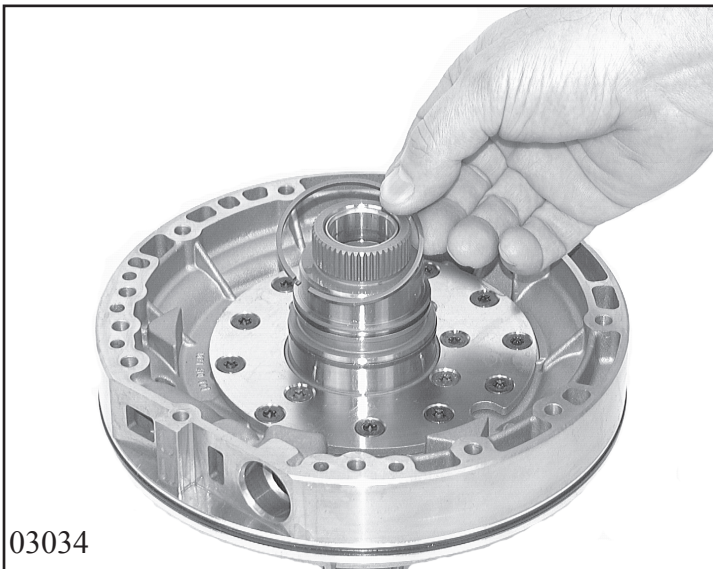

Unscrew the 11 countersunk-head machine screws (at the outer ring of the stator shaft) and remove them except for two on opposite sides. Strike the pump carefully with a plastic-faced hammer to drive it out on to these screws.

(Wrench size = Torx TX 30)

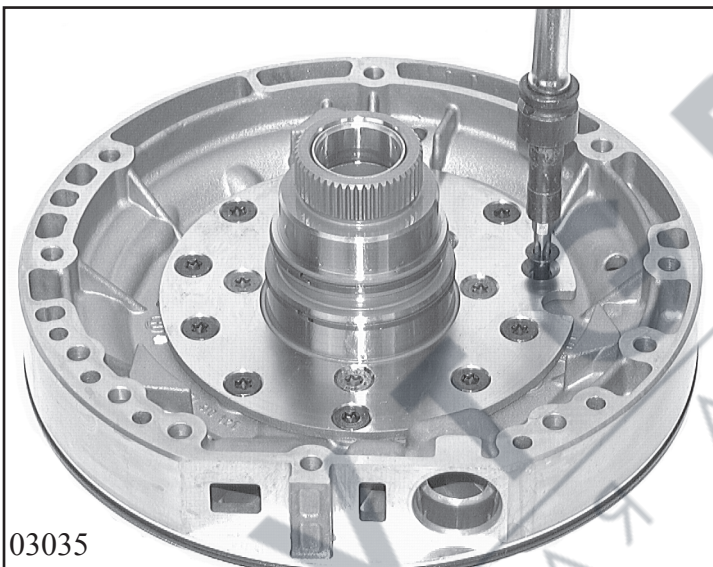

Pull off the O-ring seal. The pump can be disassembled by taking out the impeller and the ring gear.

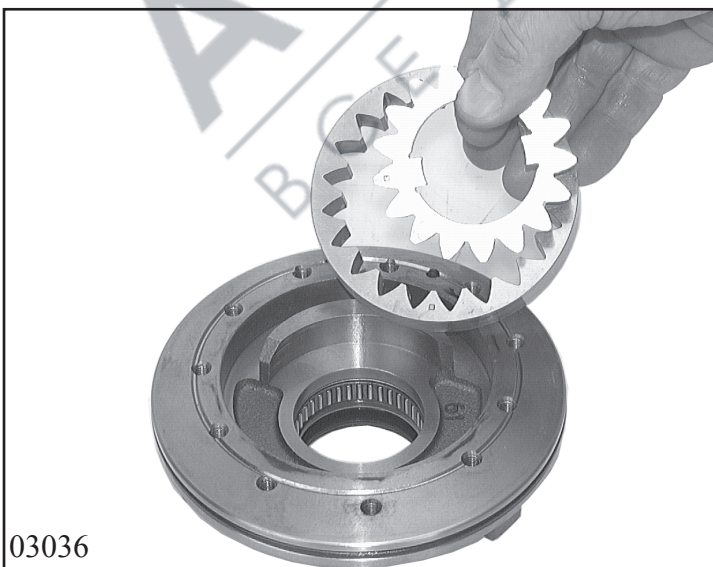

Lever out the shaft sealing ring with a suitable screwdriver. Take out the snap ring. If necessary, press the sealing ring with needle roller bearing out from the impeller side in the arbor press, using a suitable tool.

To do this, the pump casing must be turned around.

Diameter of pressure pin = app. 42 mm.

Note:

This work will damage the needle roller bearing, which must not be re-used.



Unscrew the remaining 6 countersunk-head screws, heat the casing to approx. 70°C around the stator shaft and drive the stator shaft out of the intermediate plate with a plastic-faced hammer.

(Wrench size = Torx TX 30)

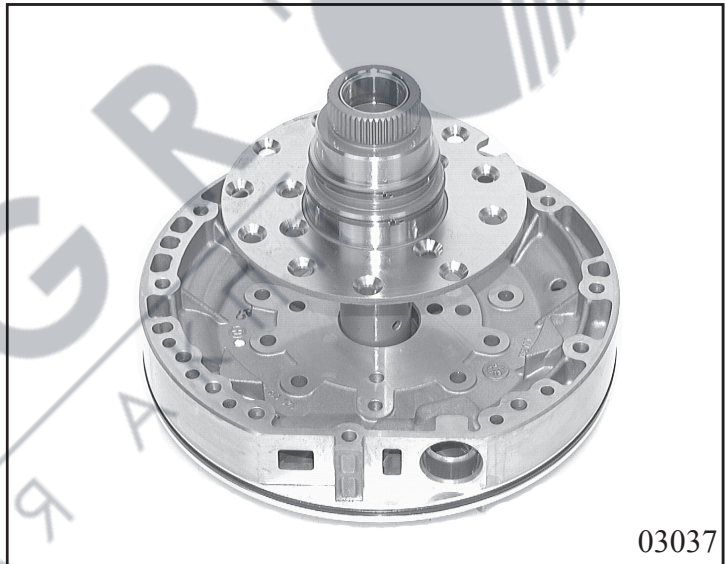

2.4 Clutch B

Evt. unclip the angled washer from the clutch B carrier.(side 2.1/4)

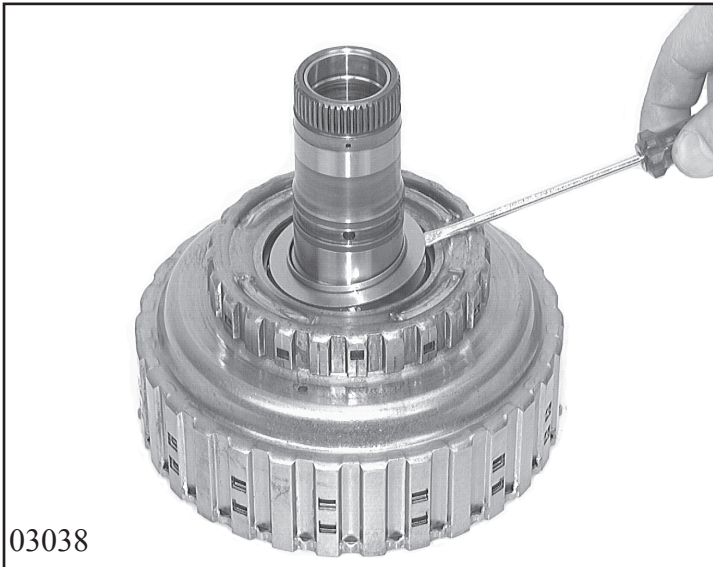

Next, turn the cylinder by 180 degrees, remove the snap ring at clutch B and take out the complete disk cluster.

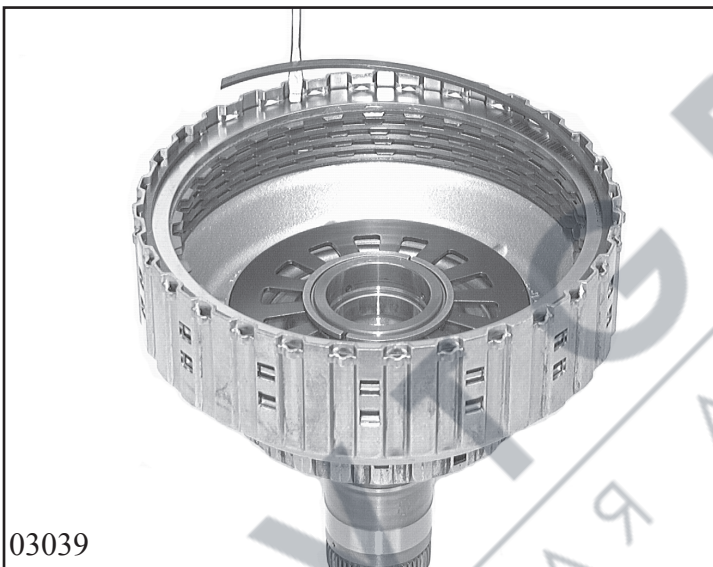

Using assembly hoop 5x46 909 248, press cup spring B out in the arbor press. Remove the split retaining ring and take out the divided cup spring.

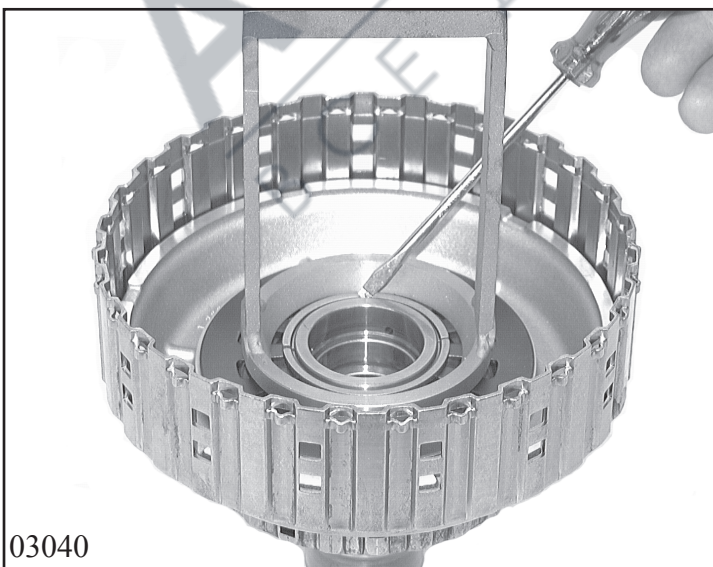

Plug one of the two oil feed holes and force piston B with retaining washer out with compressed air.
Pull off 1 O-ring from the retaining washer and 2 O-rings from the piston.
Pull the two rectangular-section rings off the shaft.

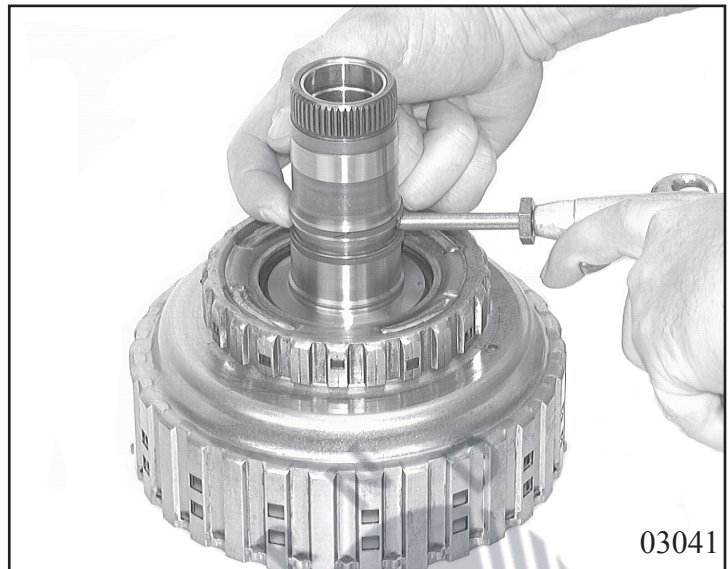

AVTGR
ВСЕ ДЛЯ АКПП

2.5 Brakes C and D



Take out the snap ring at brake D and remove the complete disk cluster. Unclip the needle roller thrust bearing cage and take out stop ring. Turn the cylinder around. Unclip the needle roller thrust bearing cage. Take out the snap ring at brake C and remove the complete disk cluster.

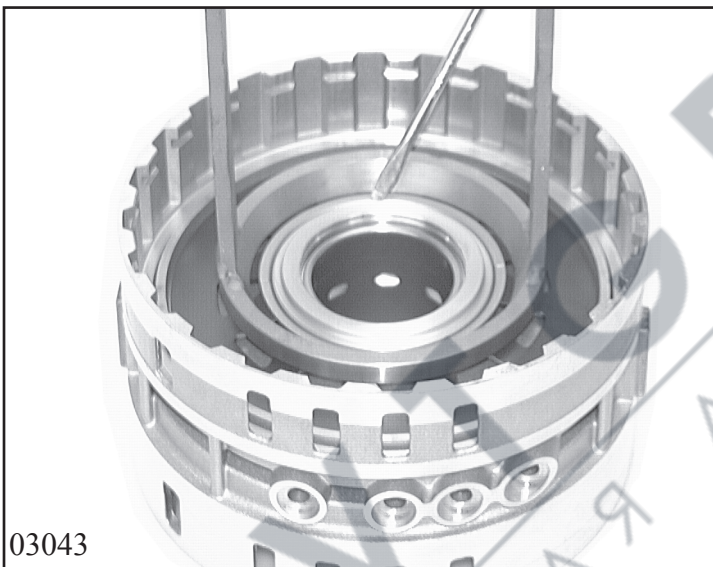

Using assembly hoop 5x46 909 247, press cup spring C out in the arbor press; take out the split retaining ring. Remove the divided cup spring

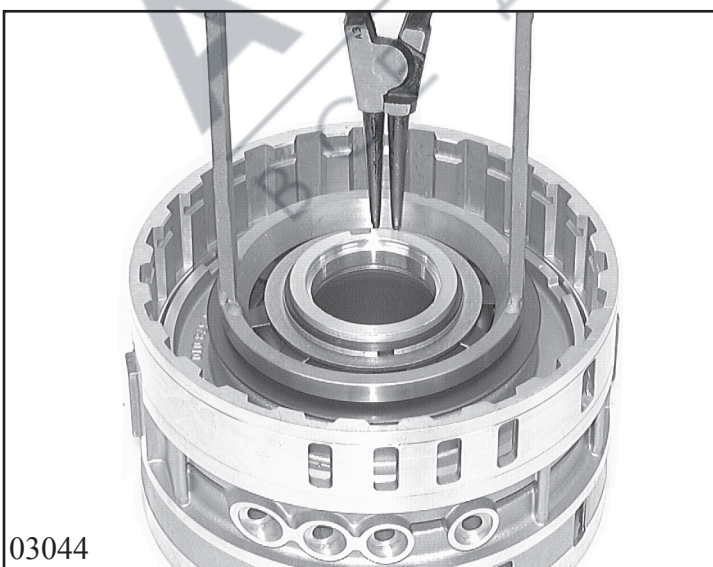

Turn the cylinder around and use assembly hoop 5x46 909 247 to compress cup spring D in the arbor press. Lever out the snap ring and remove the retaining washer and cup spring.

Use compressed air to force retaining washer D out of cylinder bore D.

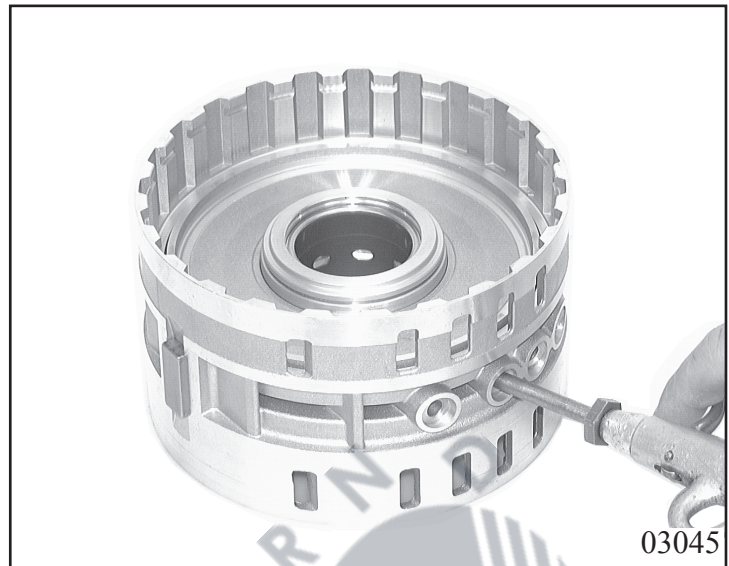

Apply compressed air carefully to the oil feed hole and force out piston D.
Pull off 1 O-ring seal from cylinder D and 3 O-ring seals from the piston.

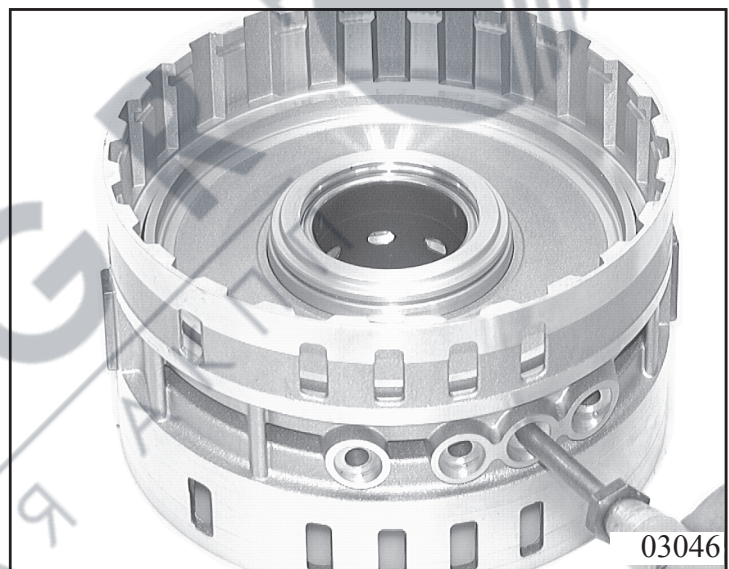

Turn the cylinder around and apply compressed air carefully to the oil feed hole to force out piston C.
Pull the 2 O-ring seals off piston C.

2.6 Output shaft with parking lock

Separate the output shaft from the ring gear by levering out the snap ring.

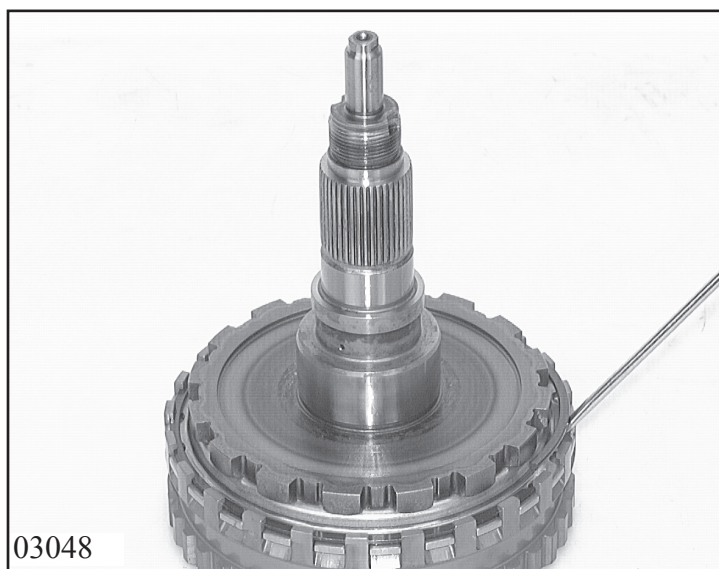



2.7 Transmission casing with shift-control and parking lock

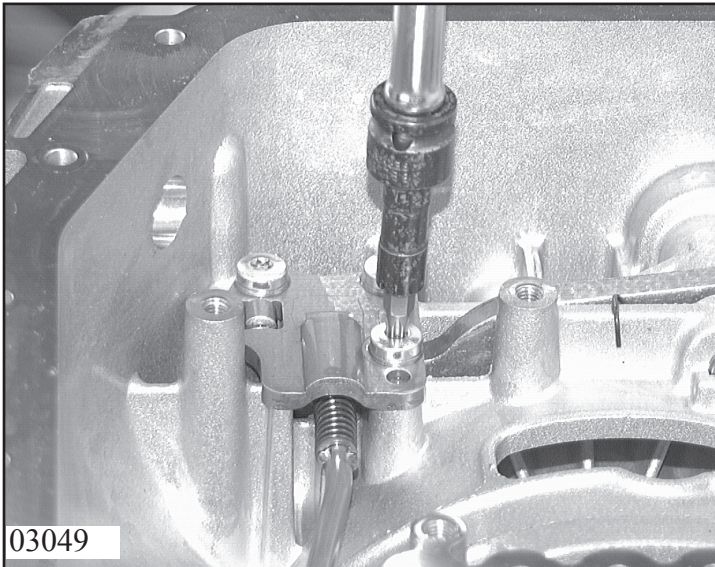

Loosen locknut and pull off lever.
Loosen the 4 machine screws and take out the guide plate.

(Wrench size = Torx TX 27)

(for E version)

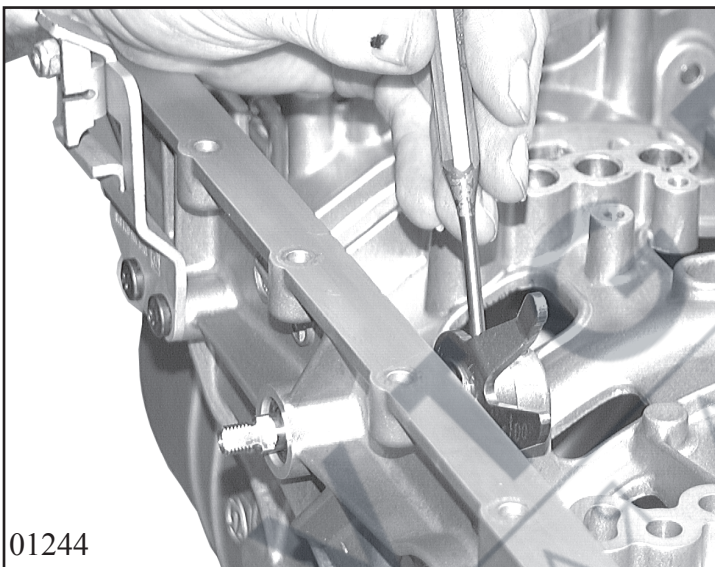

Drive clamping sleeve out of parking disk with a suitable mandrel and pull out selector shaft.
Remove sleeve and spring.

Next, take out parking disk with connecting rod. Lever out the shaft sealing ring with a screwdriver.
Loosen the 2 Torx screws for the emergency release angle and take it off.

(for M version)

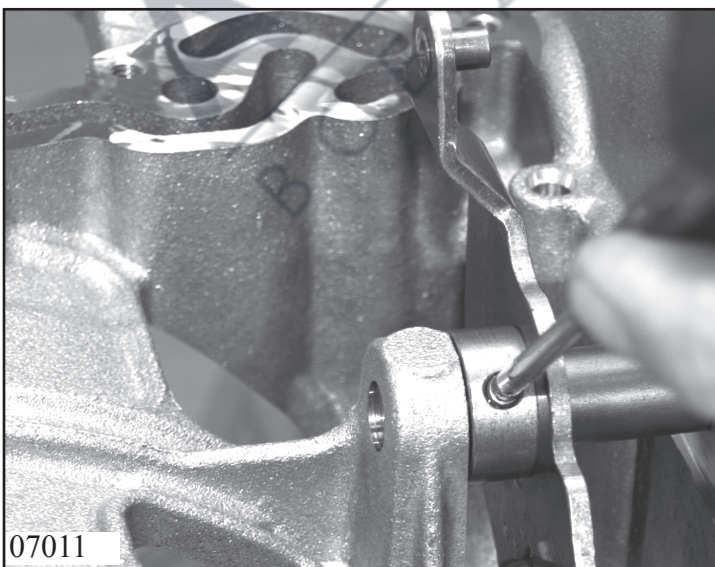

Drive clamping sleeve out of detent disk with a suitable mandrel and pull out selector shaft.

Next take out the detent disk with connecting rod. Lever out the shaft seal ring with a screwdriver.
The detent spring normally remains in the transmission casing.
To remove it, loosen the two Torx screws.

(Wrench size = Torx TX 27 H)

Remove screw plug with sealing ring.
(Wrench size = 6 mm hexagonal socket)

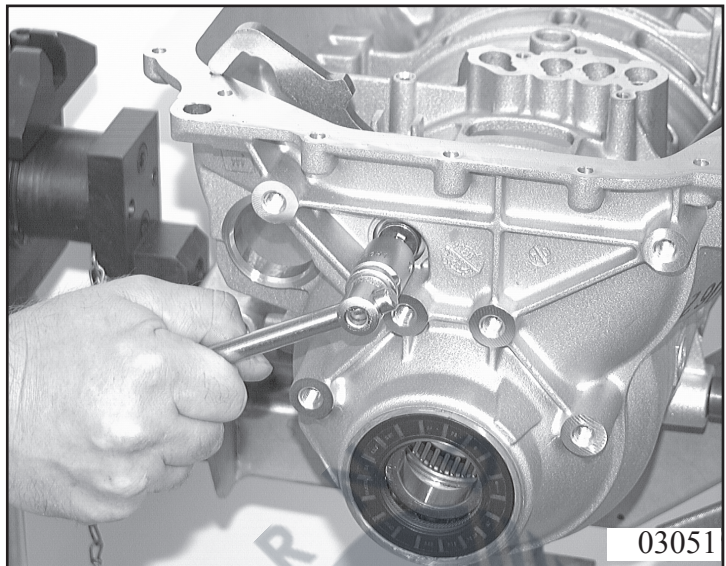

Press pin out of transmission casing. The ratchet with spring can then be taken off.

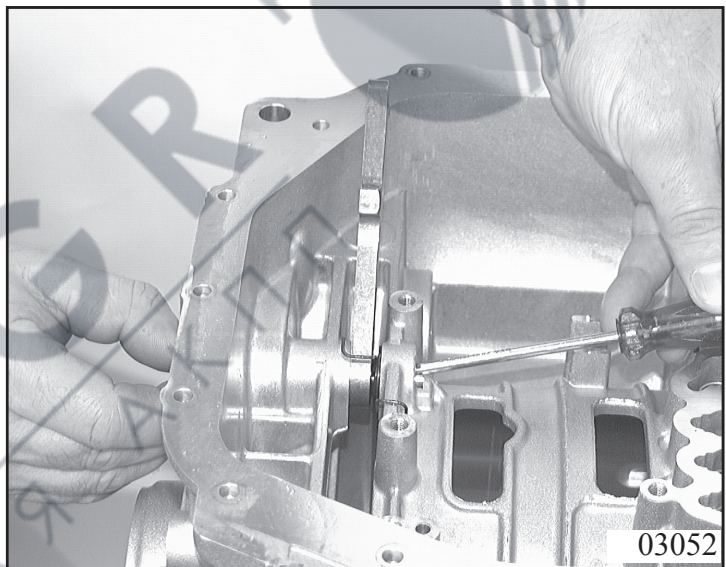

Remove the shaft sealing ring from the transmission casing with a suitable lever.
Remove the snap ring with pliers.

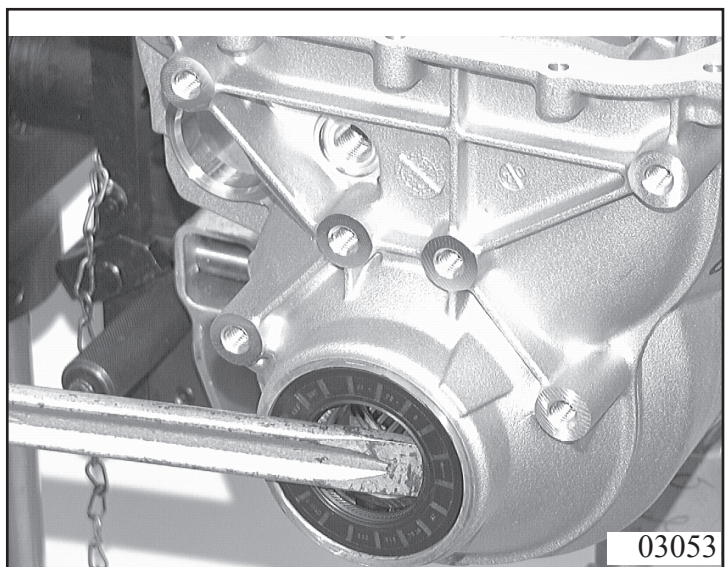

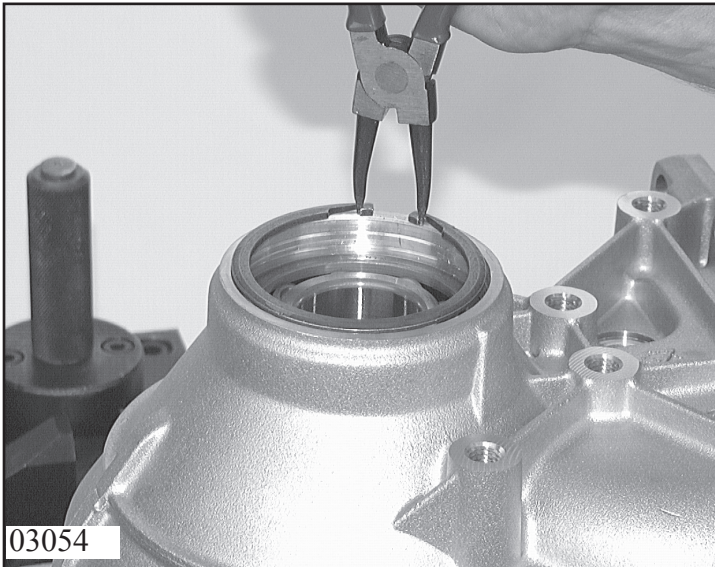

Remove the snap ring with pliers.
Press the ball bearing out of the transmission casing with a suitable mandrel.

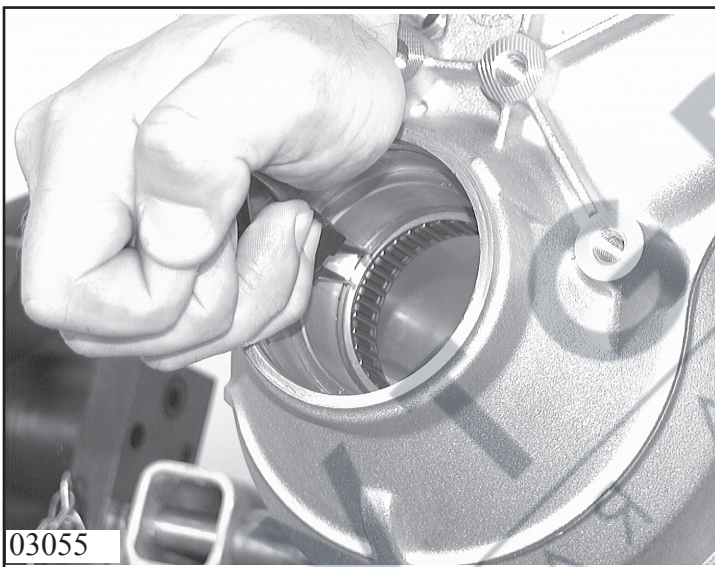

Remove the snap ring with pliers.
If necessary, heat the casing around the needle roller bearing with a fan heater to 70° C. Turn housing with output side down and remove the needle roller bearing from the transmission casing.

To clean the transmission casing, remove all the screw plugs and caps.

1 screw plug for WK (lock-up clutch) open.
(Wrench size = 5 mm hexagonal socket)

Pull 2 plastic drain plugs out of the oil cooler inlet and outlet.

Pull off 1 breather cover.



3. Assembly
3.1 Gearbox housing with shift control and parking lock

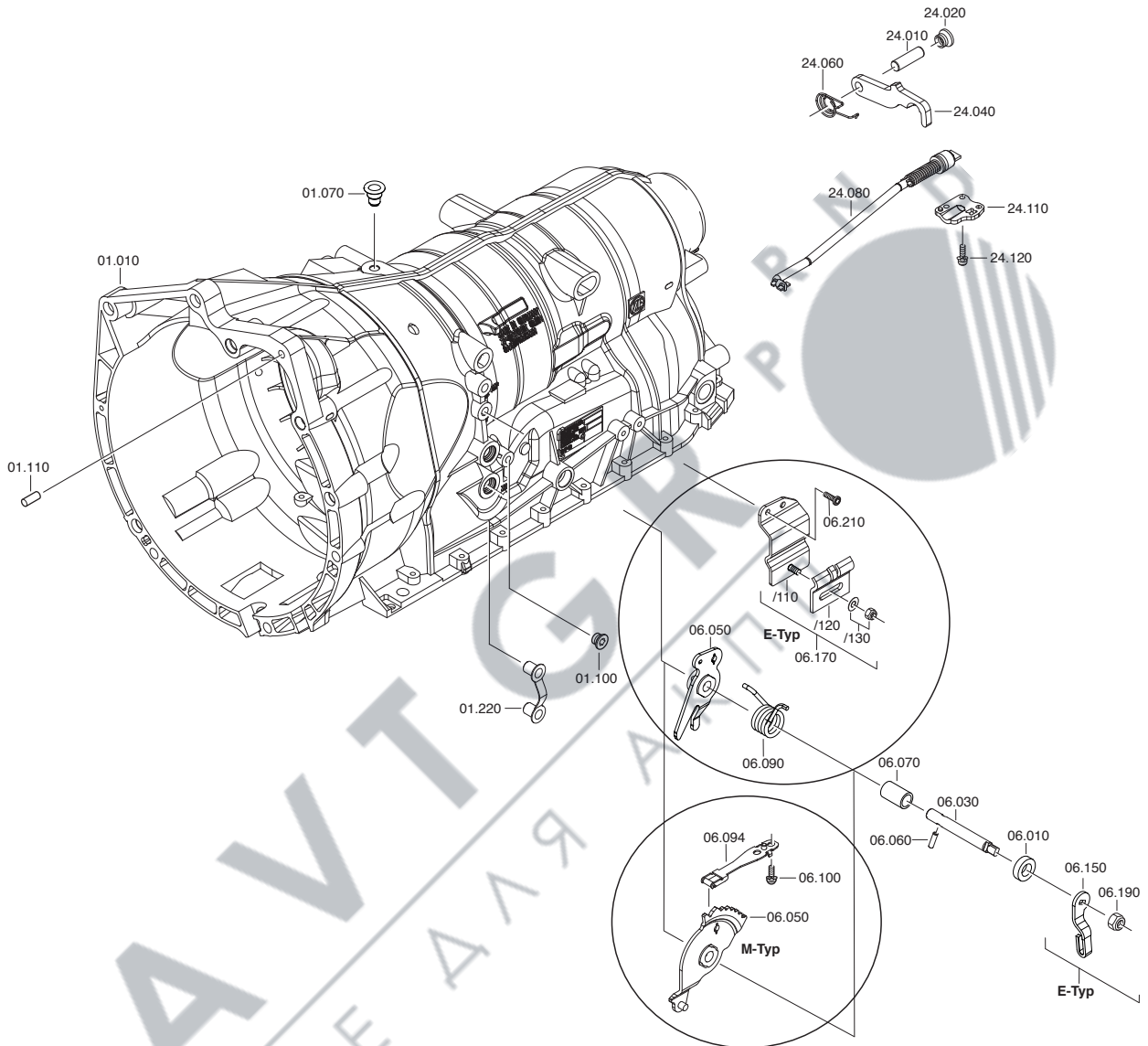

Drive breather 01.070 into gearbox housing 01.010 with a plastic-faced hammer.

Warning!

This is only necessary with a new gearbox housing

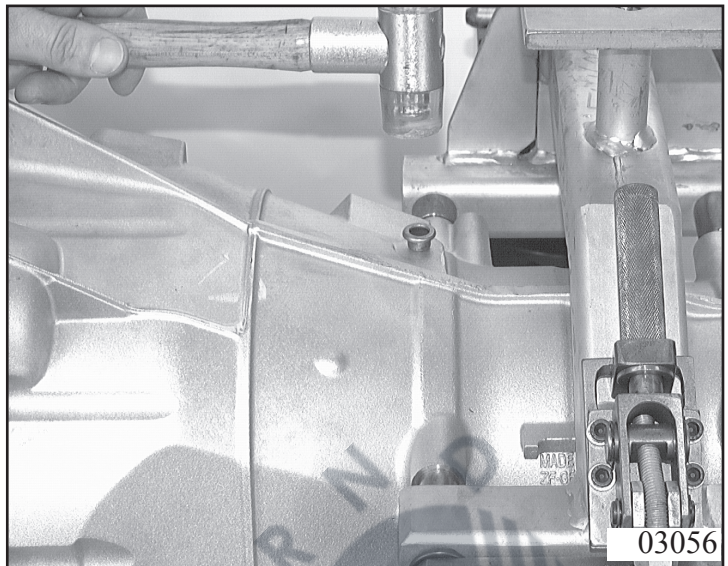

Install shaft sealing ring 06.010 in gearbox housing with pressing-in mandrel 5x46 909 345.

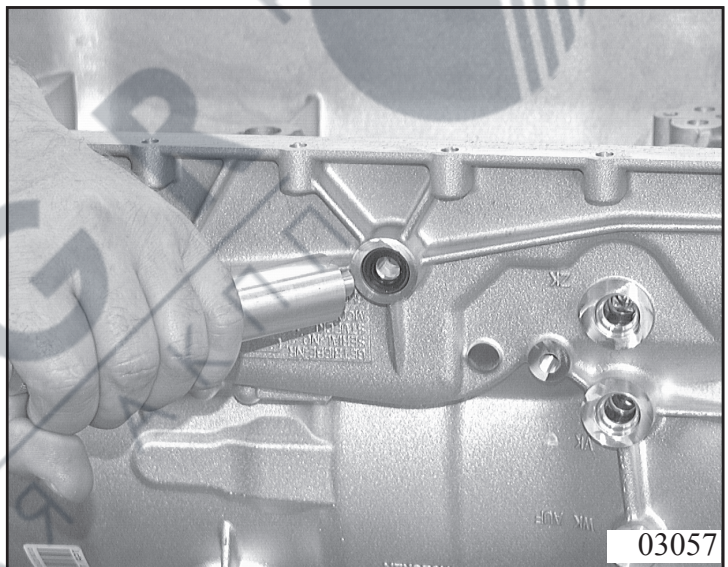

Insert new screw plug 01.100.
Press in 2 transport plugs 01.220 by hand.

(For tightening torque, see **Chapter 1.5**)

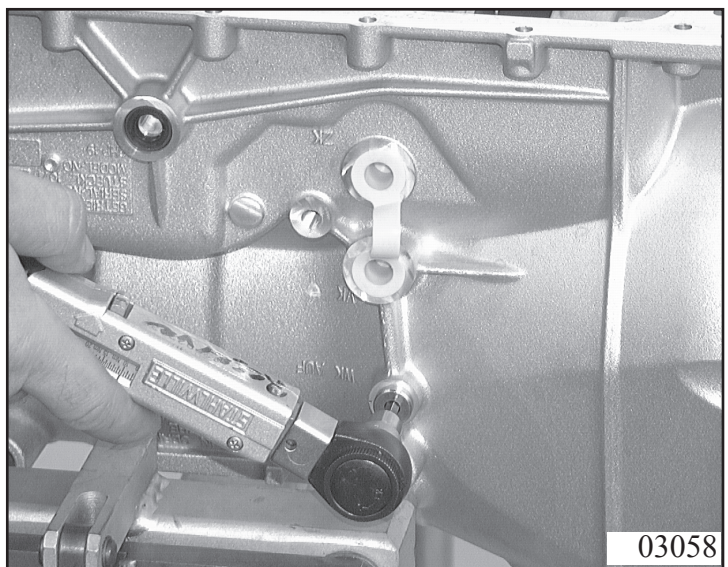

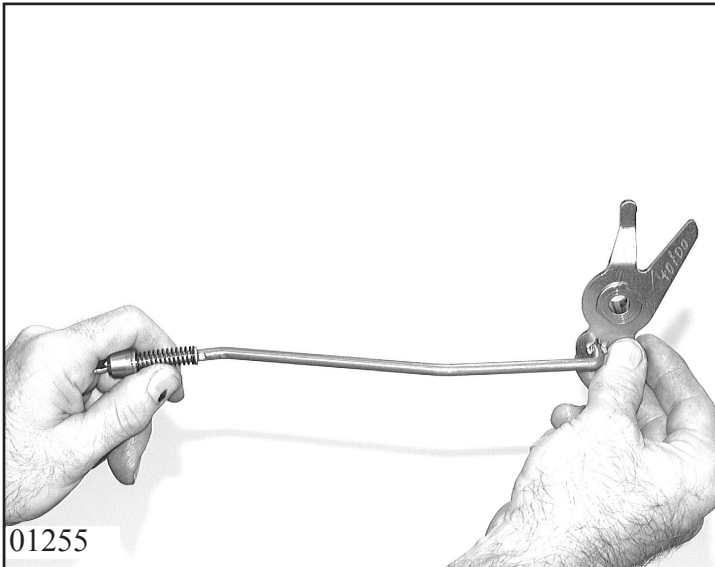

Attach connecting rod 24.080 to parking or detent disk 06.050 and turn to secure.

01255

(For M type and with new housing only)

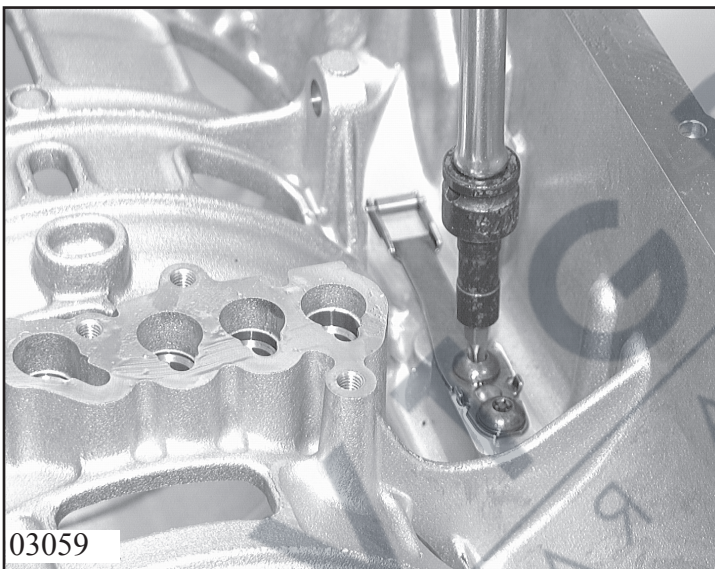

Attach detent spring 06.094 loosely with 2 Torx screws 06.100, so that the detent spring can still be repositioned slightly.

03059

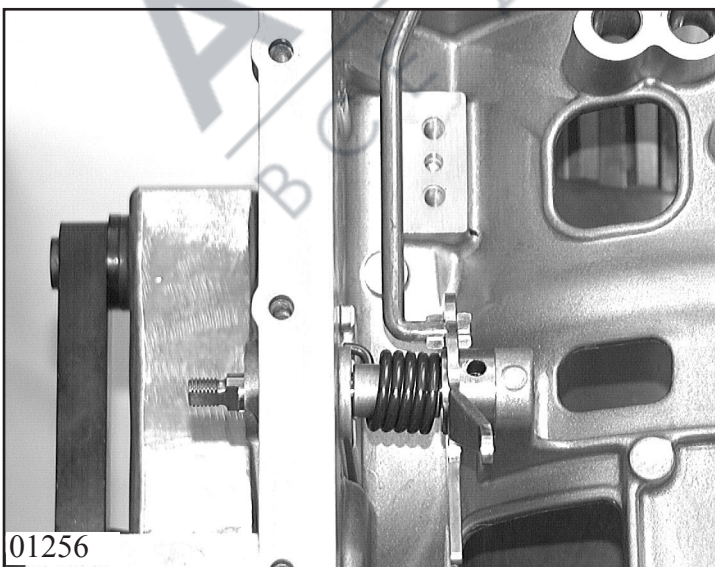

Insert parking or detent disk with connecting rod into gearbox housing and push selector shaft 06.030 in through sleeve 06.070 and detent disk.

01256

Warning!

For the E type, first push spring 06.090 over selector shaft.

(E type only)

Drive in new dowel pin 06.060 with striker pin 5x46 000 291 or an appropriate mandrel in the correct position.

Warning: E type

Slight spring pre-tensioning is required to permit installation of the parking lock when there is no current flow.

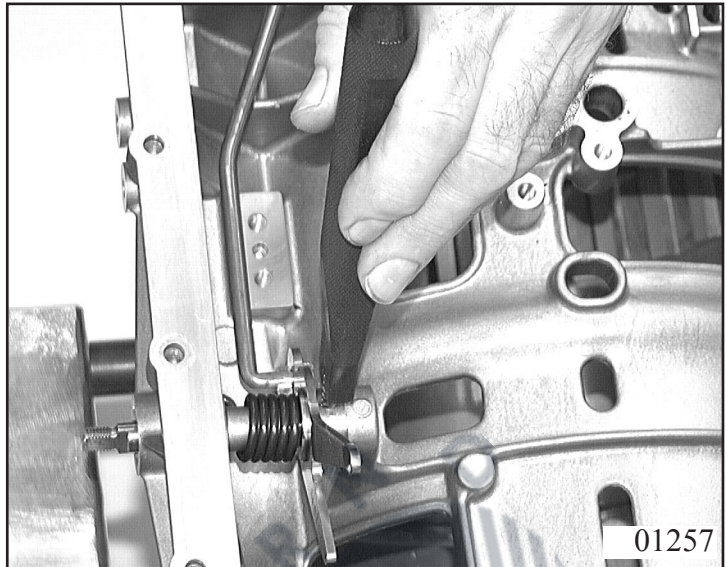

(M type only)

Drive in new dowel pin 06.060 with striker pin 5x46 000 291 or an appropriate mandrel in the correct position.

Warning!

Adjustment required! See Chapter 1.4.8

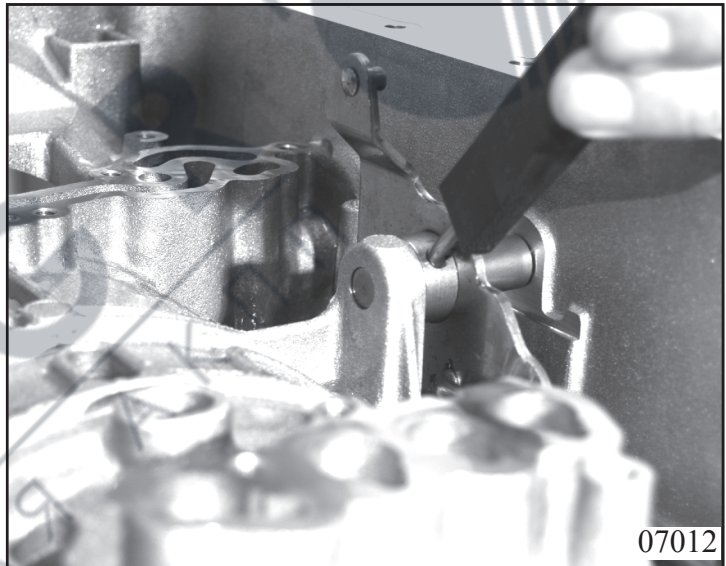

Insert ratchet 24.040 with torsion spring 24.060 into gearbox housing and fasten by pressing in pin 24.010. Then close the bore with screw plug and sealing ring 24.020.

(For tightening torque see **Chapter 1.5**)

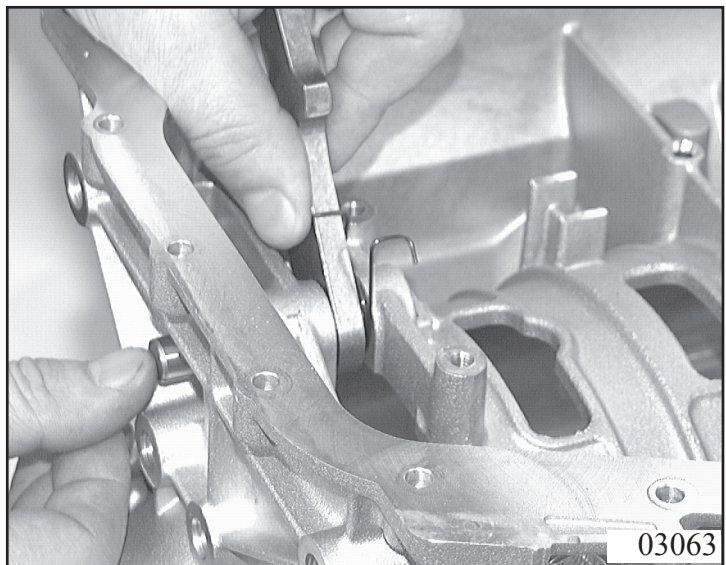

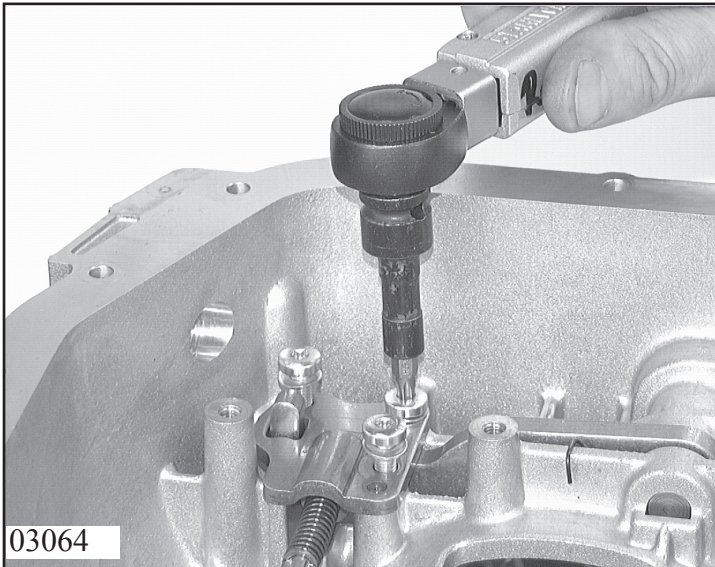

Press down ratchet and fasten guide plate 24.110 with 3 Torx screws 24.120.

(For tightening torque see **Chapter 1.5**)

(E type only)

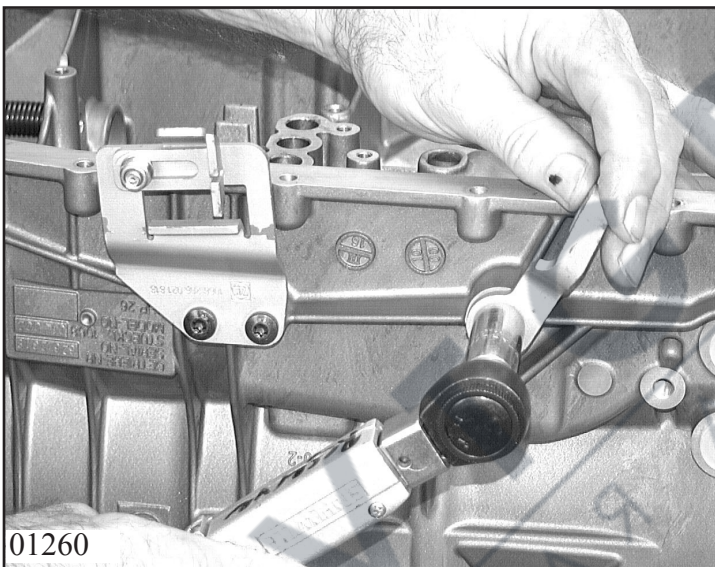

Attach emergency release angle 06.170 with two Torx screws 06.210
Fasten lever 06.150 facing the oil pan side with nut 06.190.

(For tightening torque see **Chapter 1.5**)



3.2 Output shaft with parking lock and planetary gear set

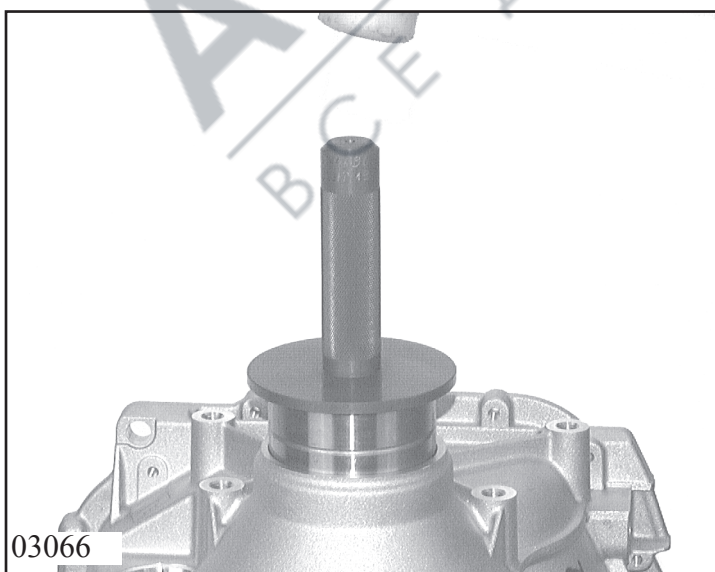
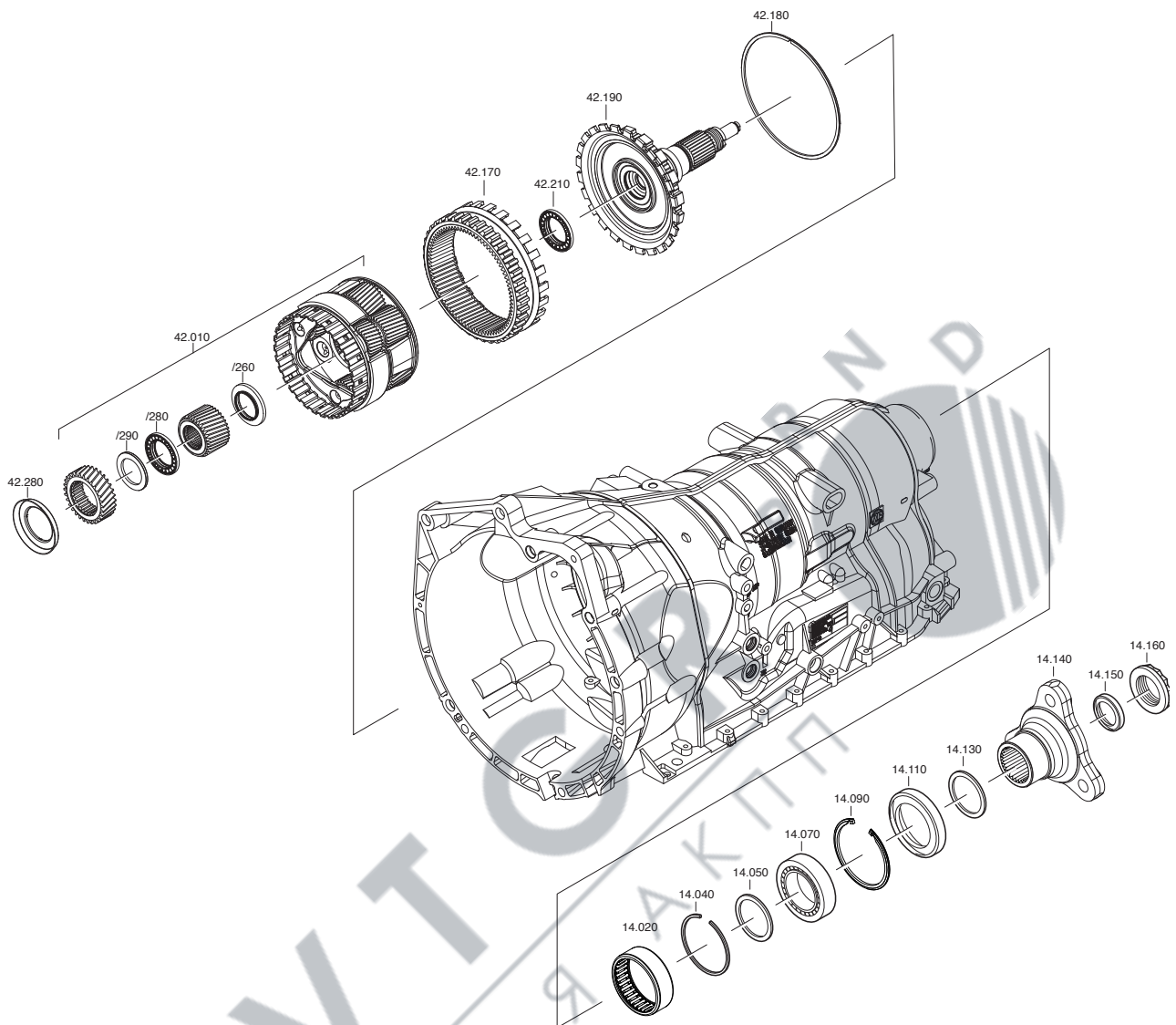

Press needle roller bearing 14.020 into transmission casing using mandrel 5x46 909 346 and supporting ring 5x46 909 347. Secure with snap ring 14.040

Note:
exchange snap ring

Press ball bearing 14.070 into transmission casing using mandrel 5x46 909 346 and secure with snap ring 14.090.

Warning!

Exchange snap ring!
Position snap ring correctly in the groove.

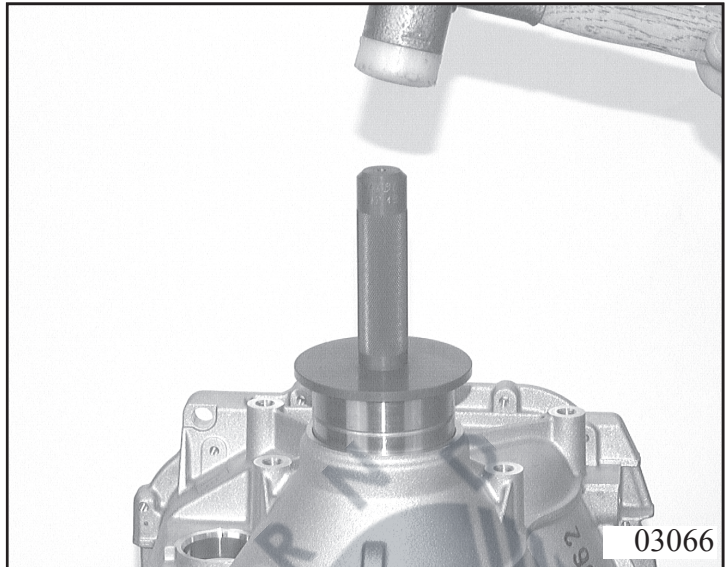

Press shaft sealing ring 14.110 into transmission casing using mandrel 5x46 002 567.

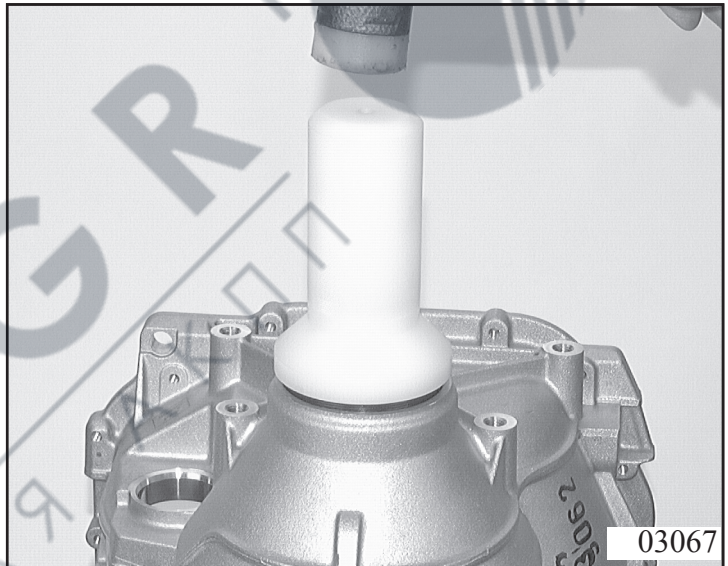

Mount ring gear 42.170 with snap ring 42.180 on output shaft 42.190. Push bearing 42.210 into output-shaft. Secure compensating washer 14.050 previously removed with grease to the output shaft. Turn the transmission by 90°. Insert output shaft into transmission casing.

Note:

If compensate washer is incorrect with regard to the end float output, half of the transmission needs to be stripped later. It is recommended to insert the removed compensating washer.

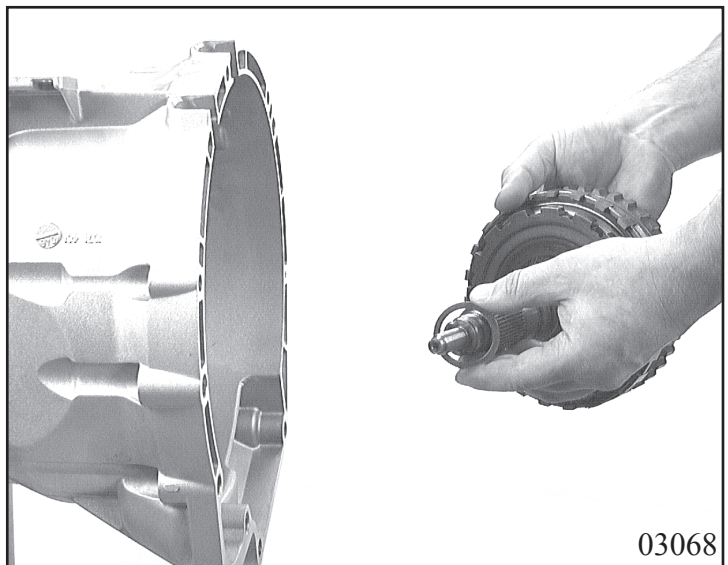

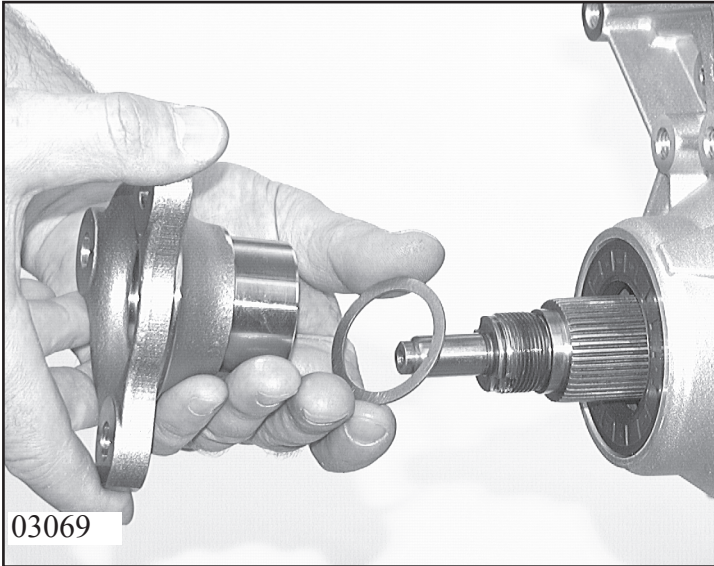

Place reversing disk 14.130 over drive shaft, push flange onto output shaft.

Note:

For adjusting work, see **Chapter 1.4.6**.
Mount flange with shaft sealing ring only onto output shaft with groove.
(For tightening torque, see **Chapter 1.5**)

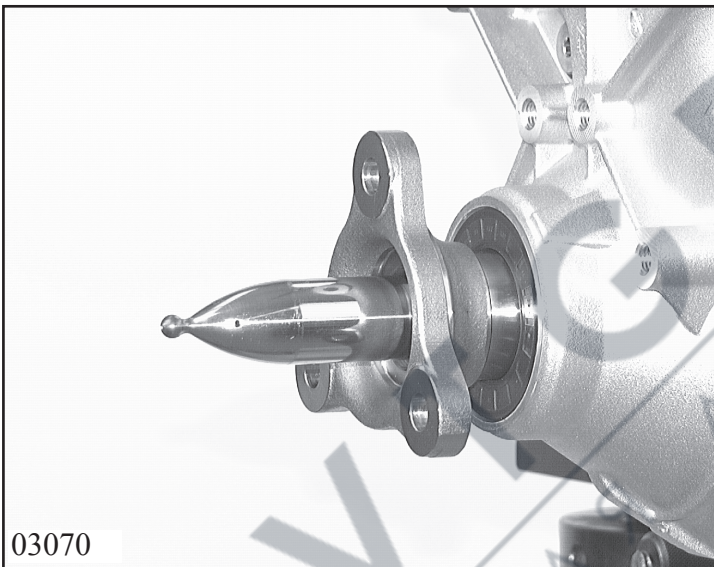

Place sealing ring 5x46 012 696 with press-in aid over drive shaft.

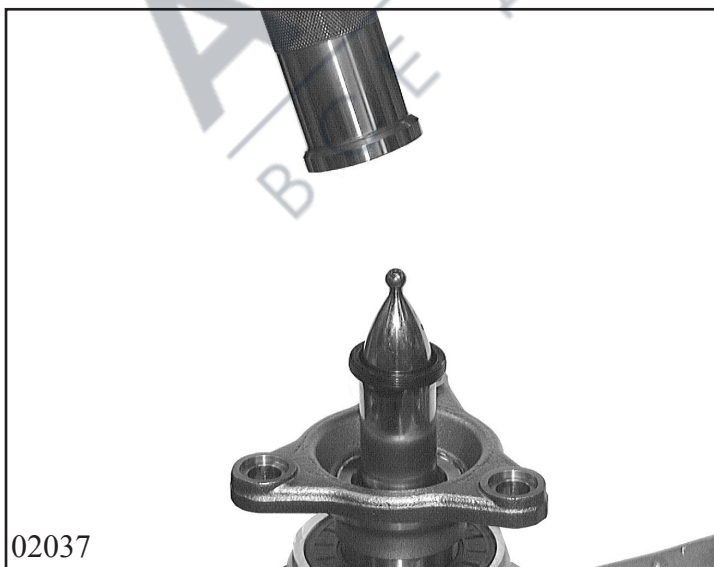

Press shaft sealing ring 14.150 into output flange 14.140 using mandrel 5x46 002 849.
Then tighten castellated nut 14.060 loosely

Insert axial bearing 42.010/260 into planetary gear set.

Clip bearing 42.010/280 in sun wheel 3 (small) and insert it with phase on top in planetary gear set.

Push sun wheel 3 in inserted bearing.

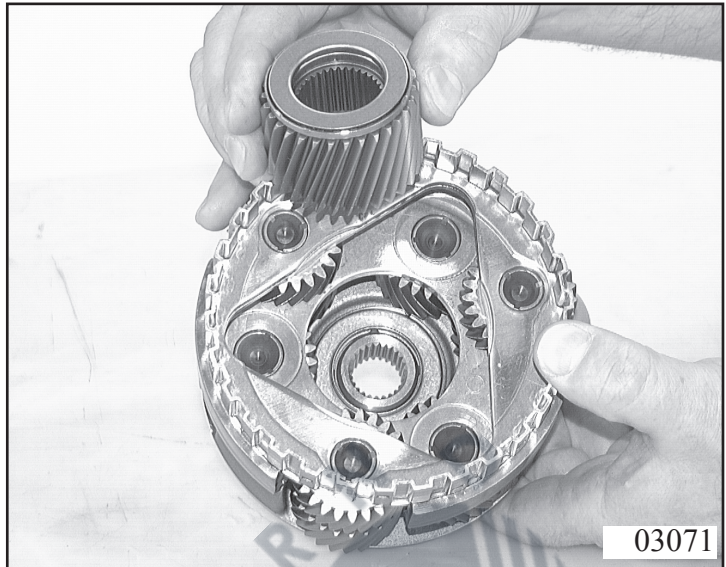

Turn transmission with converter bell upwards.

Insert planetary gear set into transmission casing.

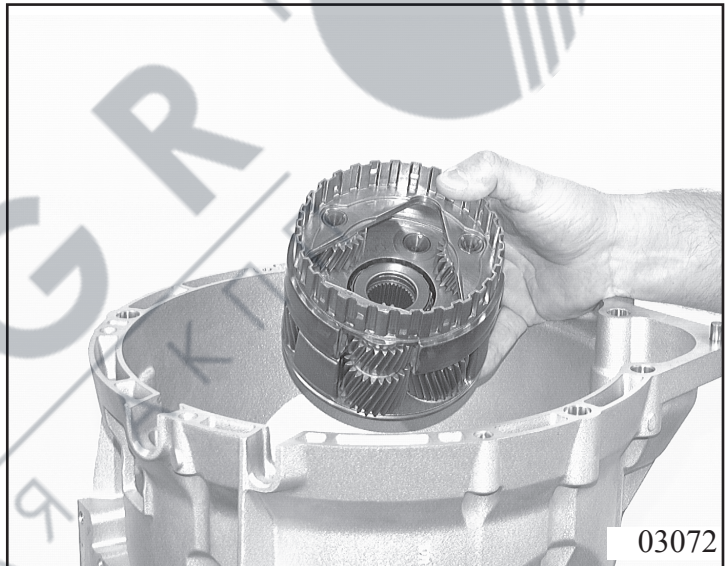

Clip bearing disk 42.010/290 and bearing cup 42.280 into sun wheel 2.

Insert sun wheel 2 into planetary gear set.



3.3 Brakes C and D

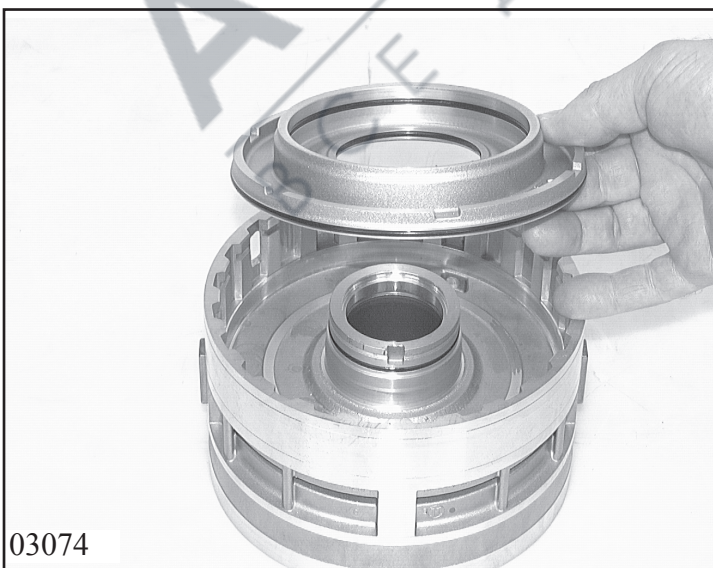
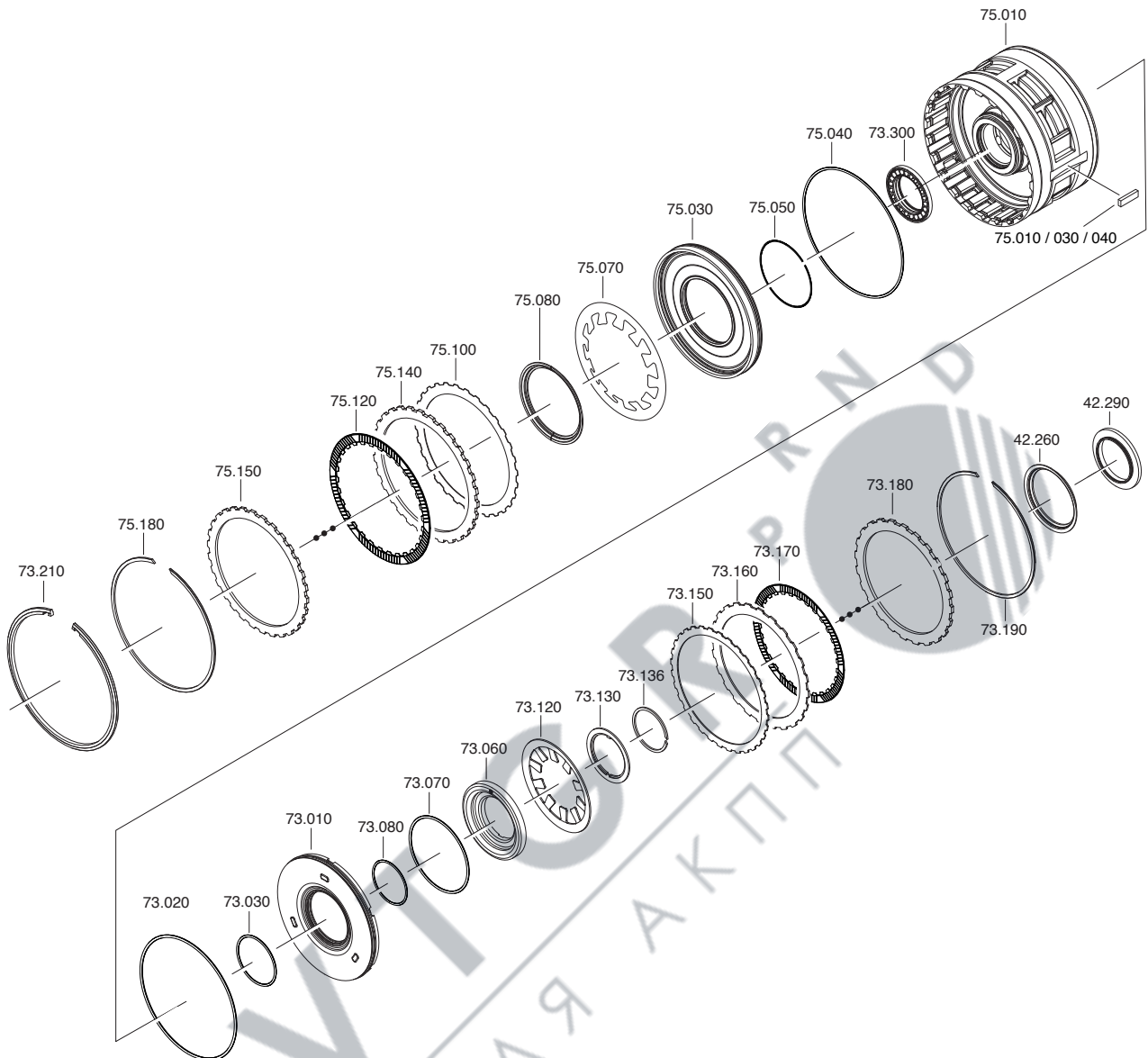

Drive 2 shaft keys 75.010/030, /040 in centrally at cylinder CD 75.010, using a plastic hammer.

Put 3 new O-ring seals 73.020, 73.030 and 73.070 onto piston D 73.010 and 1 O-ring seal 73.080 onto cylinder CD 75.010.

Press piston D into cylinder CD.

Pull baffle plate 73.060 into piston D.
 Insert cup spring 73.120 and support
 shim 73.130 and positioning with ridge
 on top.
 Put assembly mandrel 5x46 909 539 on
 hub cylinder D. Put snap ring 73.136 on
 top and press with assembly sleeve 5x46
 909 539 under mandrell press until snap
 ring is locked.

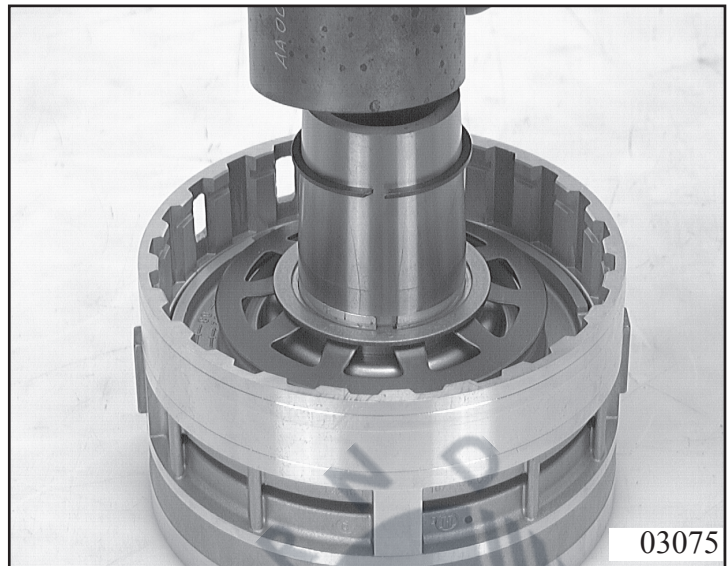

Turn cylinder CD by 180°.
 Put 2 O-ring seals 75.040 and 75.050
 onto piston C 75.030 and press it into the
 cylinder.

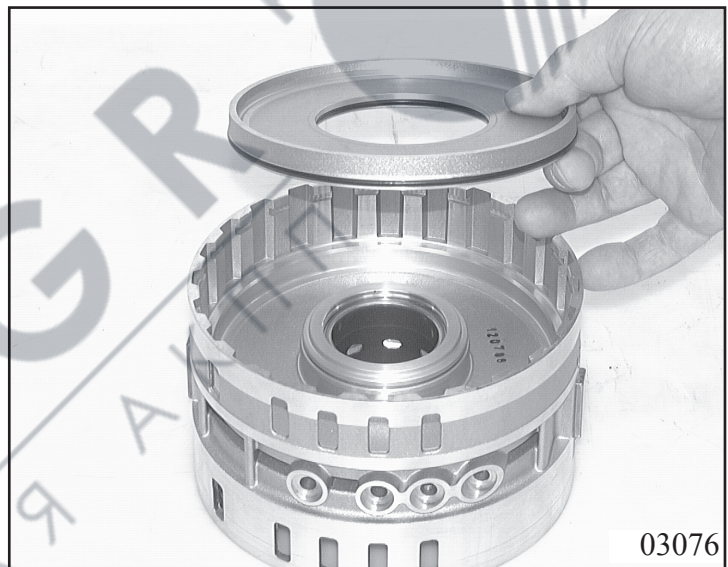

Insert cup spring C 75.070.
 Press down cup spring C in the mandrel
 press with assembly bracket 5x46 909
 247 and secure with divided snap ring
 75.080.

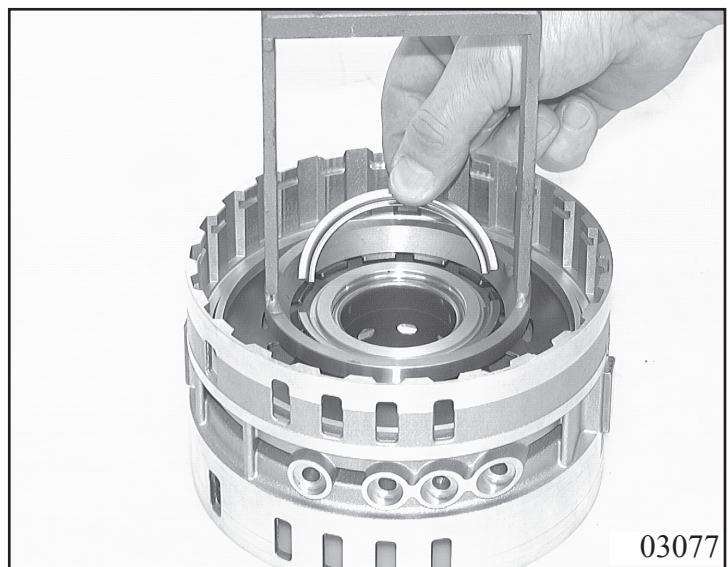

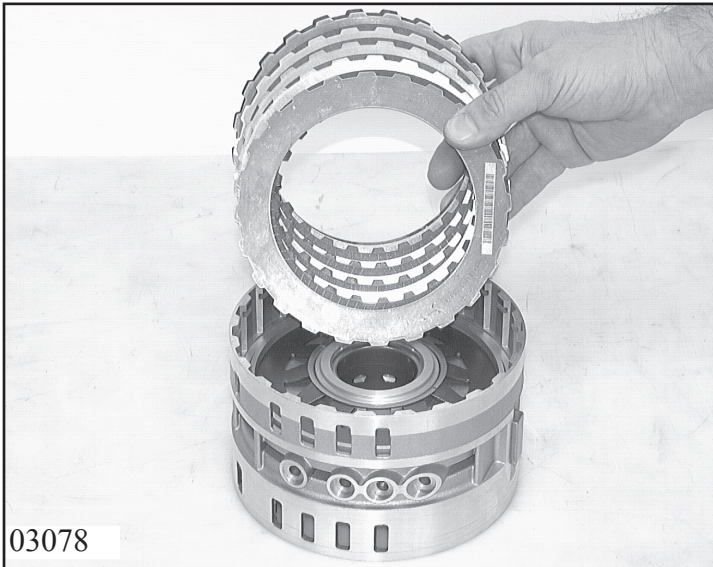

03078

Insert complete clutch pack C into cylinder CD, starting with spring disk 75.100. Then insert an outer disk 75.140 and a lined disk 75.120 alternately. Secure the top outer disk 75.150 with snap ring 75.180. Clip needle bearing 73.300.

Note:
For adjusting work see **Chapter 1.4.1**



07003

Turn cylinder CD, fit stop ring 42.260 and clip axial needle bearing 42.290 into position at the cylinder web.

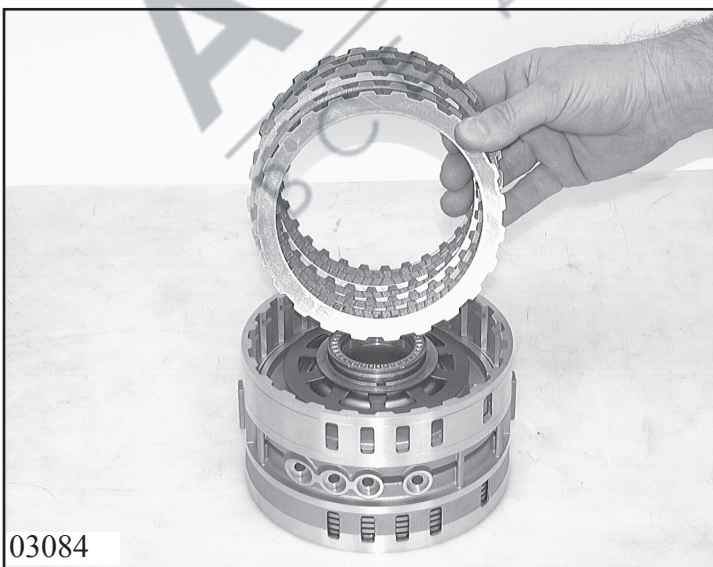

03084

Insert complete clutch pack D into cylinder CD, starting with spring clutch disk 73.150 and then insert lined disk 73.170 and outer disk 73.160 alternately. Secure the last outer disk 73.180 with snap ring 73.190.

Note:
For adjusting work see **Chapter 1.4.2**

Insert cpl. cylinder CD into transmitting housing by turning slightly the output shaft.

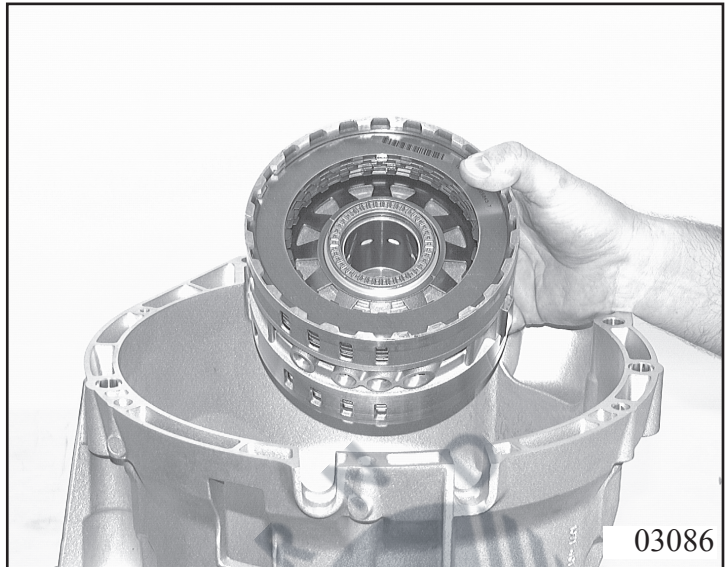

Secure with snap ring 73.210.
Use driving-in tool 5x46 001 930 to drive the snap ring into the housing groove all round.

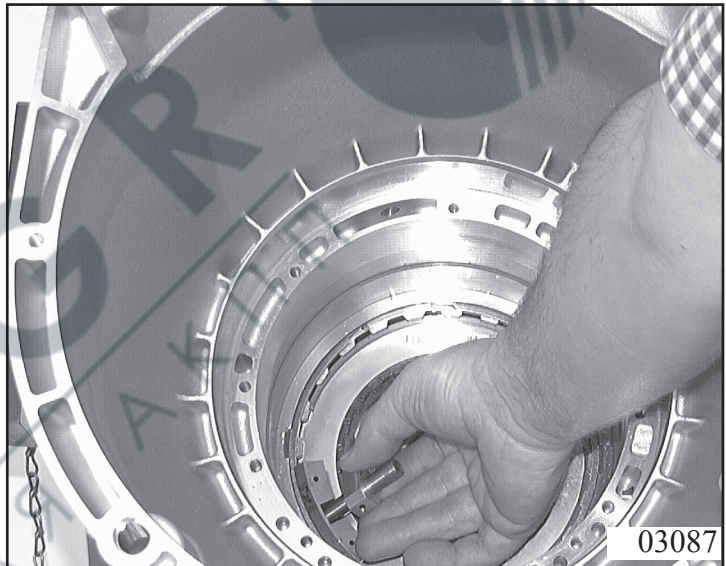

Note
Detach the handle of the tool to make it easier to use.

Turn transmission by 90°.
Insert parking lock.
Tighten castle nut with nut wrench 5x46 002 456 and peen.

Note:
For adjusting work see **Chapter 1.4.6**

If the toleranc range is exceeded the complete interior up to the adjusting spacer is to be removed and a matching disk to be chosen.

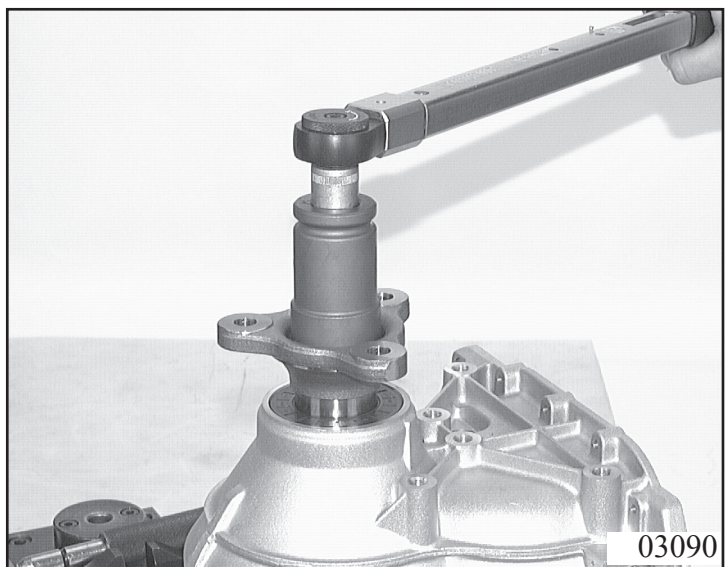

3.4 Clutch B

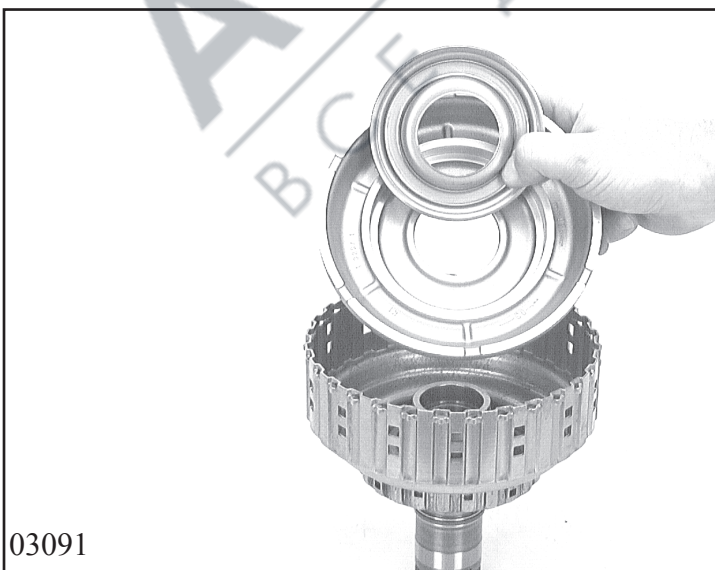
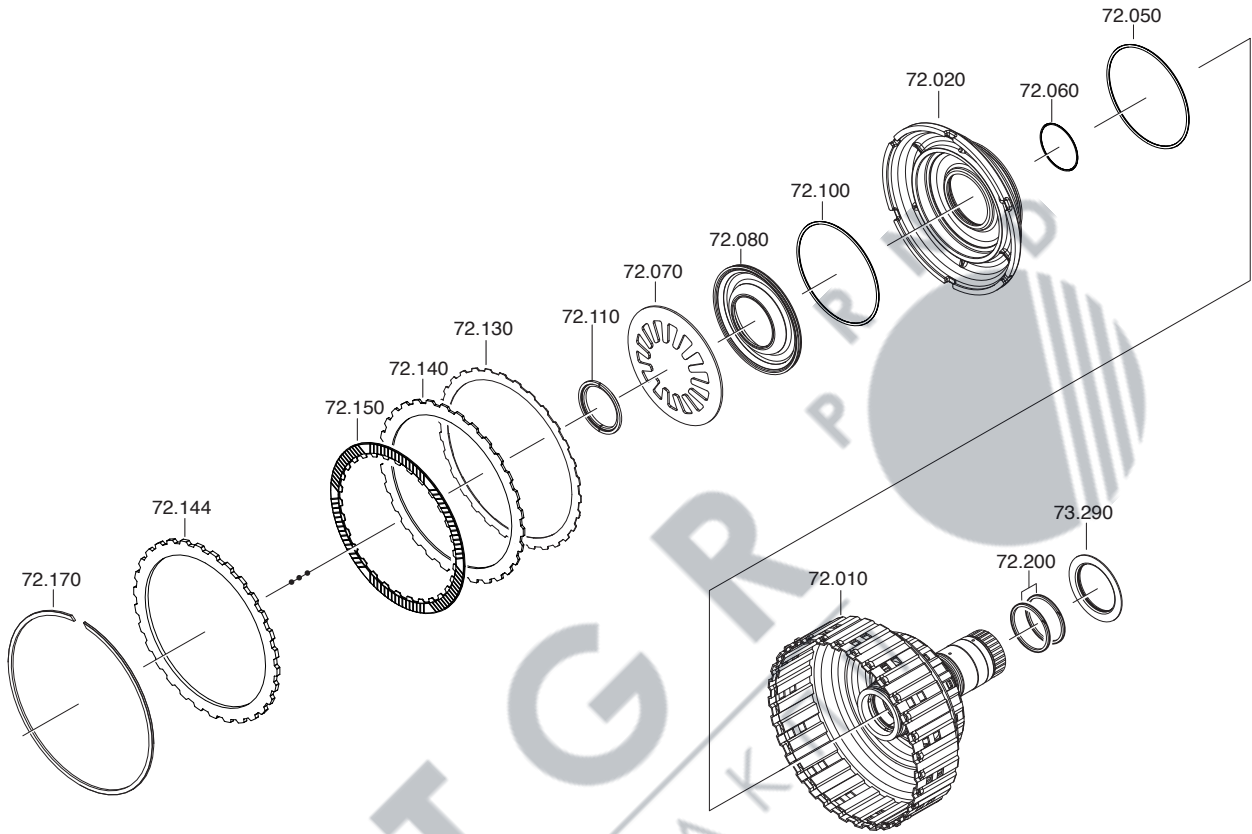

Install new O-ring seals 72.050 and 72.060 on piston B 72.020.
Press piston into cylinder B 72.010.
Pull O-ring seal 72.100 onto baffle plate 72.080 and press this into the piston.

03091

Insert cup spring B 72.070. Press cup spring down with assembly bracket 5x46 909 248 in the madrel press and secure with divided stop ring 72.110.

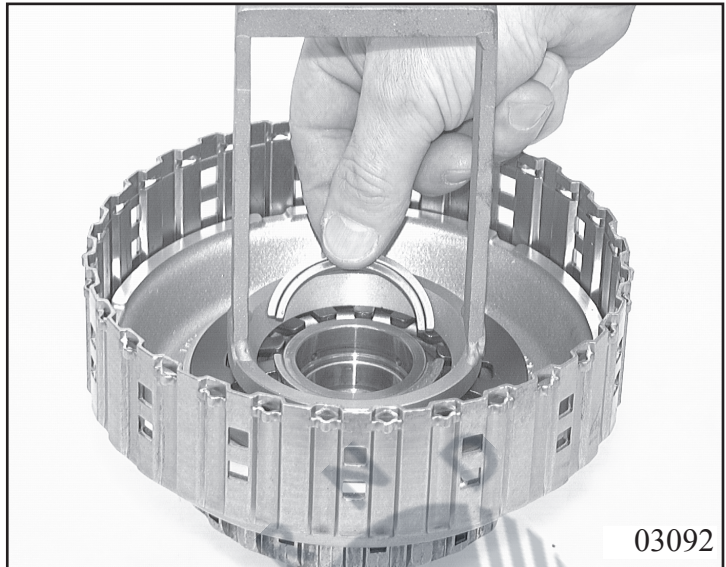

Insert complete clutch pack B, starting with spring disk 72.130. Then insert outer disk 72.140 and lined disk 72.150 alternately. Secure the last outer disk 72.144 with snap ring 72.170.

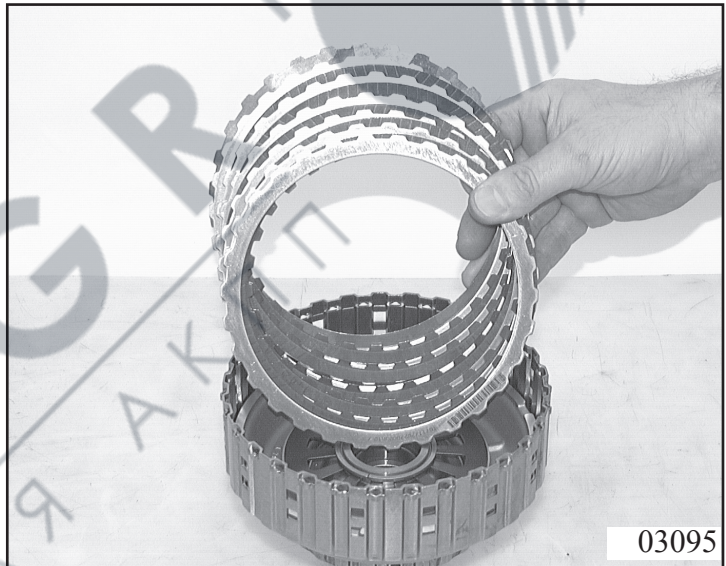

Warning!
For adjusting work see **Chapter 1.4.3**

Turn the cylinder and pull 2 rectangular-section rings 72.200 onto cylinder B. Fix angle disk 73.290 with vaseline.

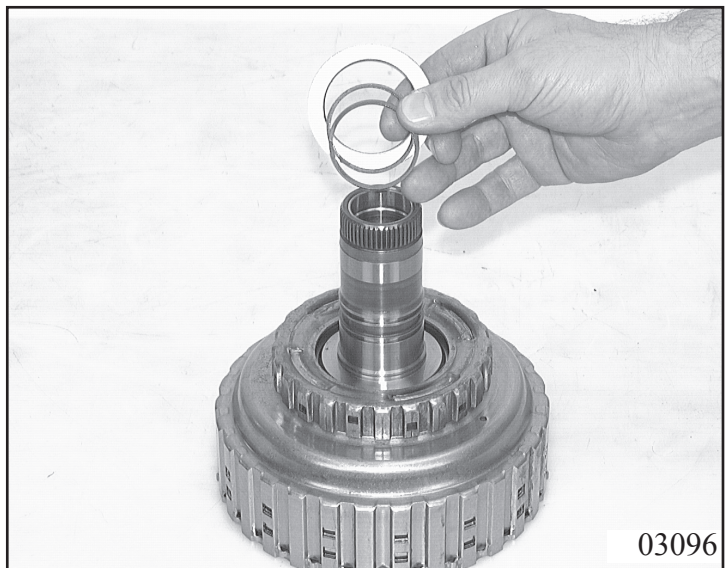

Warning!
Secure new rectangular-section rings in the groove with Vaseline.

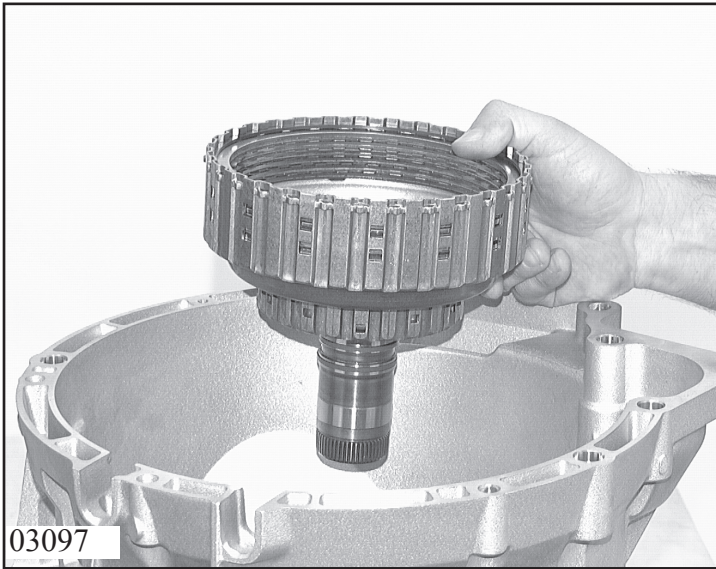

Insert complete clutch B into transmission housing.





3.5 Turret (drive with clutches A and E)

3.5.1 Clutch E (drive)

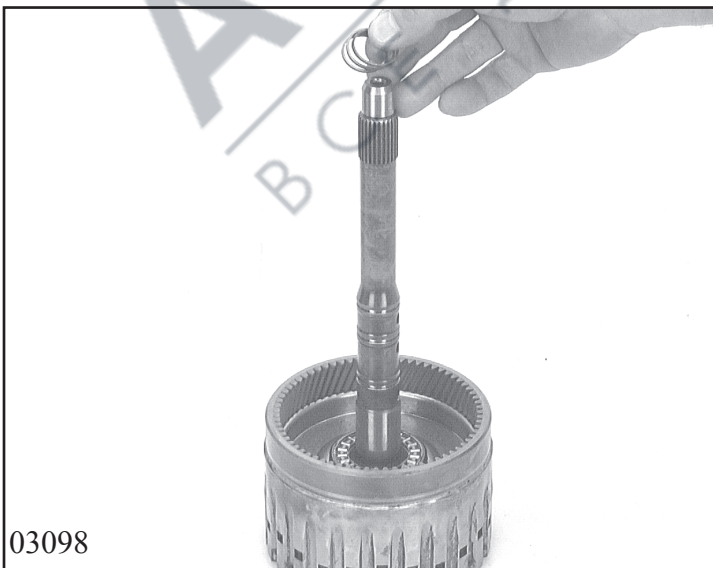
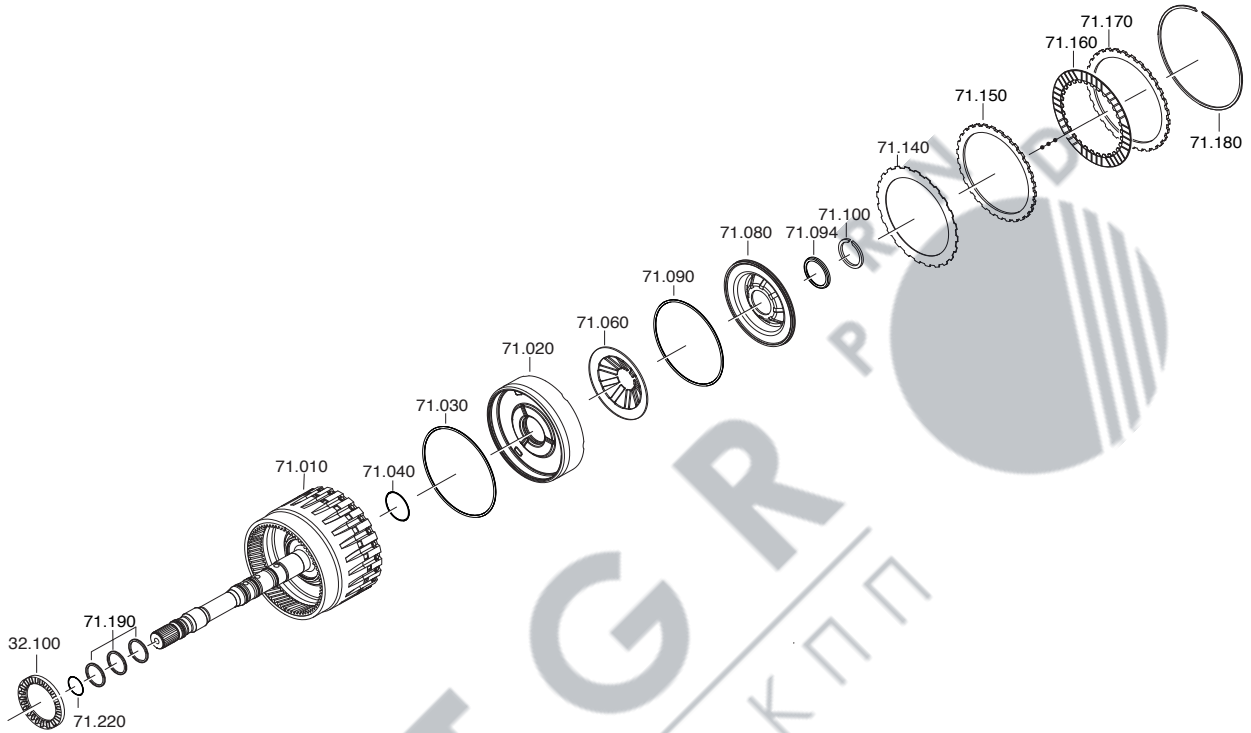

Put 3 new rectangular-section rings 71.190 and one o-ring 71.220 onto cylinder E 71.010 with input shaft.

Note:

When dismantled, clip axial needle roller bearing cage 32.100 into cylinder (ring gear side).

Put new seal rings 71.030 and 71.040 onto piston E 71.020.
Press piston E into cylinder E.

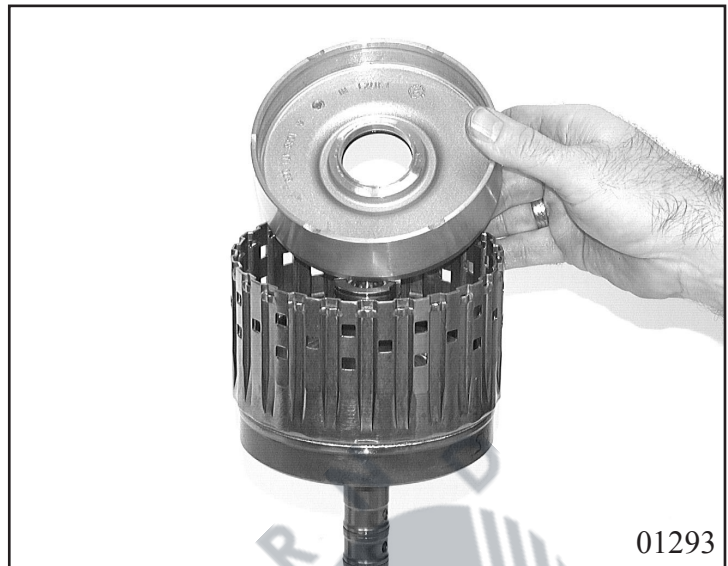

Put new O-ring seal 71.090 onto baffle plate 71.080. Insert cup spring 71.060 into cylinder E with the projections facing upwards and press in the baffle plate.
Insert bracket 71.094.

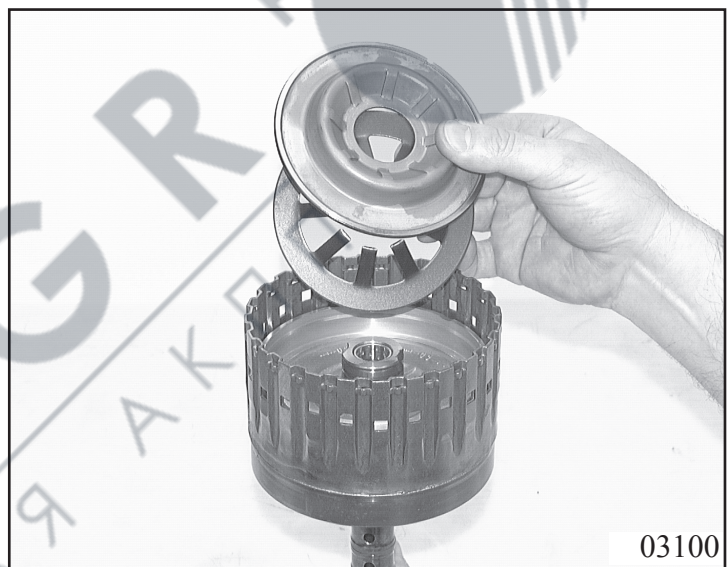

Insert assembly adapter 5x46 003 343.
Put **new** snap ring 71.100 on top.
Press pipe with snap ring and cup spring down in the mandrel press until the snap ring engages in the slot.

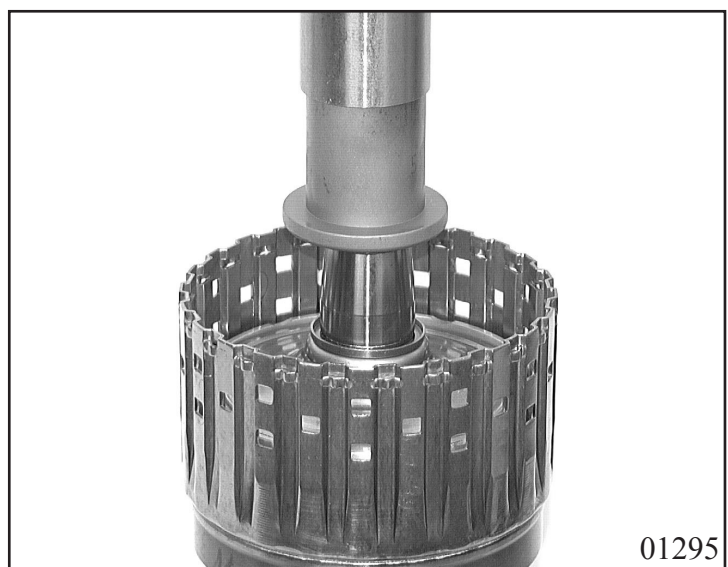

Note:
exchange snap ring

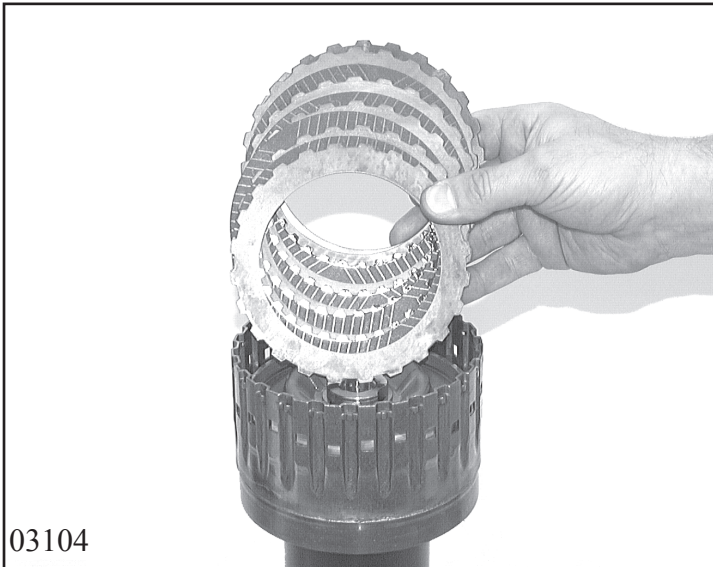

Insert complete clutch pack E. Start with spring disk 71.140, then insert outer disk 71.150 and lined disk 71.160 alternately. Insert final disk 71.170 and secure with snap ring 71.180.

Note:
For adjusting work, see **Chapter 1.4.5**

AVTGR
ВСЕ ДЛЯ АКПП
P R N D

3.5.2 Clutch A (input)

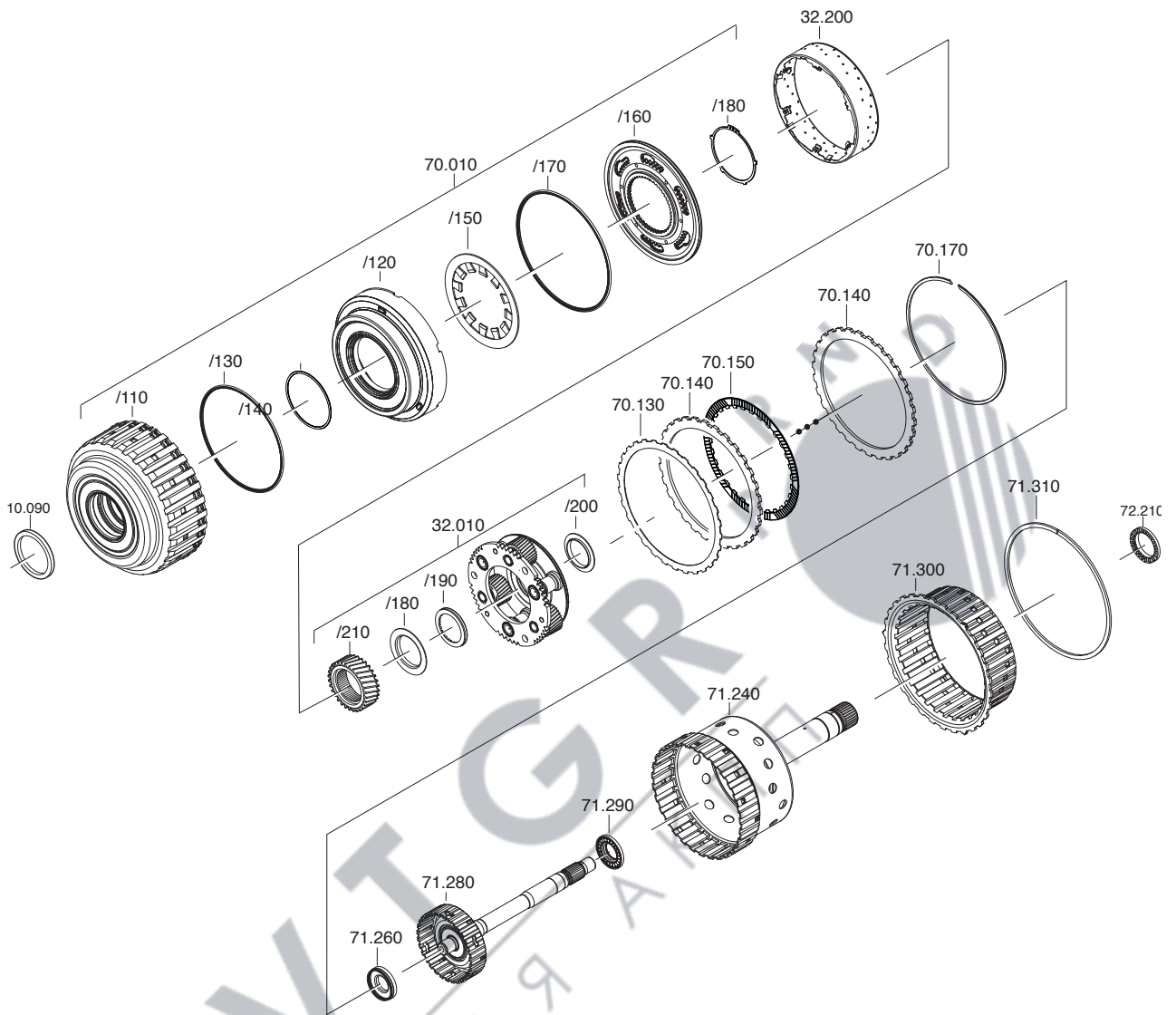

Put 1 new prof. seal ring 70.010/130 and
 1 new O-ring seal 70.010/140 onto piston
 A 70.010/120.
 Press piston A into cylinder A 70.010/110.

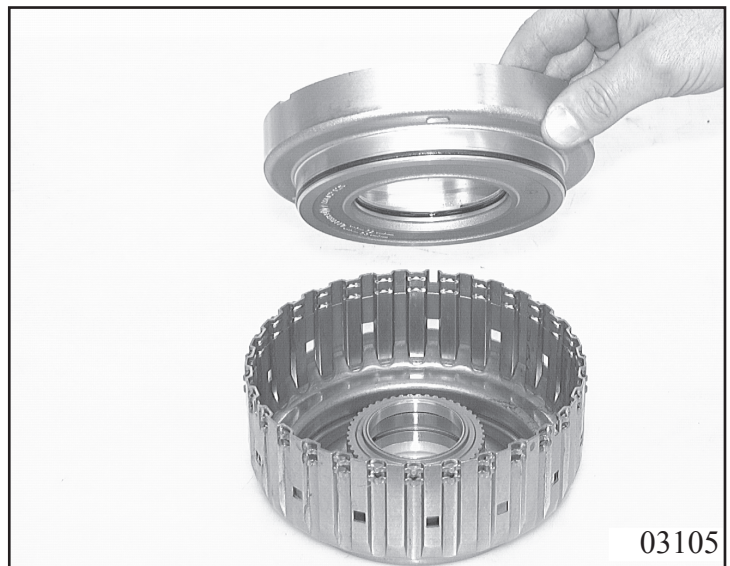

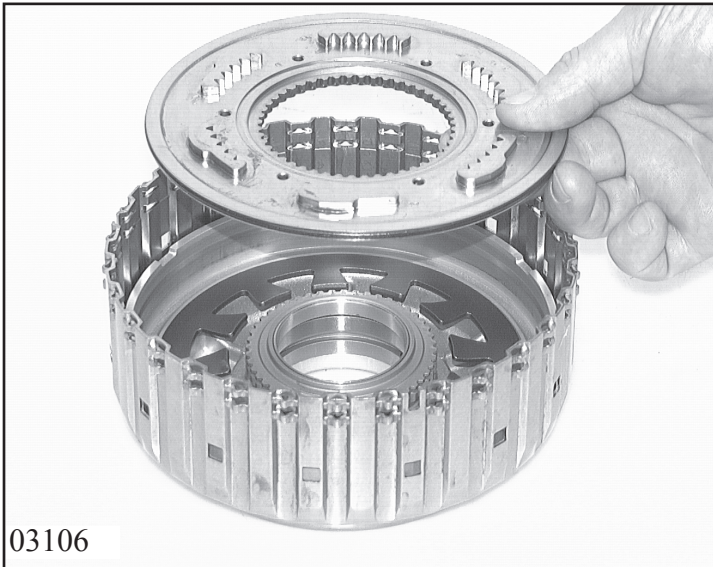

03106

Insert cup spring 70.010/150.
Put prof. seal ring 70.010/170 onto baffle plate 70.010/160 and insert the baffle plate into the cylinder.
Press the cup spring down in the mandrel press with assembly bracket 5x46 909 247 and secure with K-ring 70.010/180.



03109

Insert complete clutch pack A. Start with spring disk 70.130, then insert outer disk 70.140 and lined disk 70.150 alternately.
Secure the top outer disk 70.140 with snap ring 70.170.

Note:
For adjusting work, see **Chapter 1.4.4**

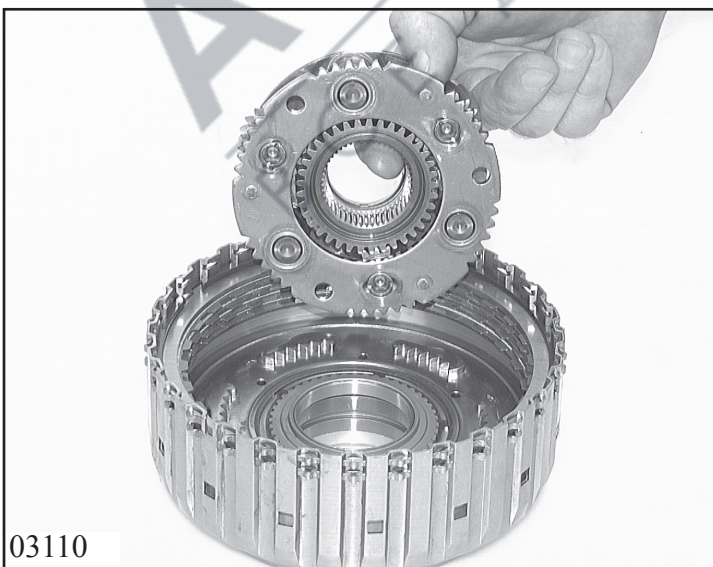

03110

Insert sun wheel 32.010/210 with axial needle cage 32.010/190 facing the inside of the planet gear set 32.010.

Insert complete planet gear set into cylinder A.
Insert new oil drip pan 32.200 into cylinder A, turn left till stop. To secure push projections down with screw driver.

Insert complete clutch E into clutch A.
Clip axial needle roller bearing 71.260
onto hub of cylinder E.

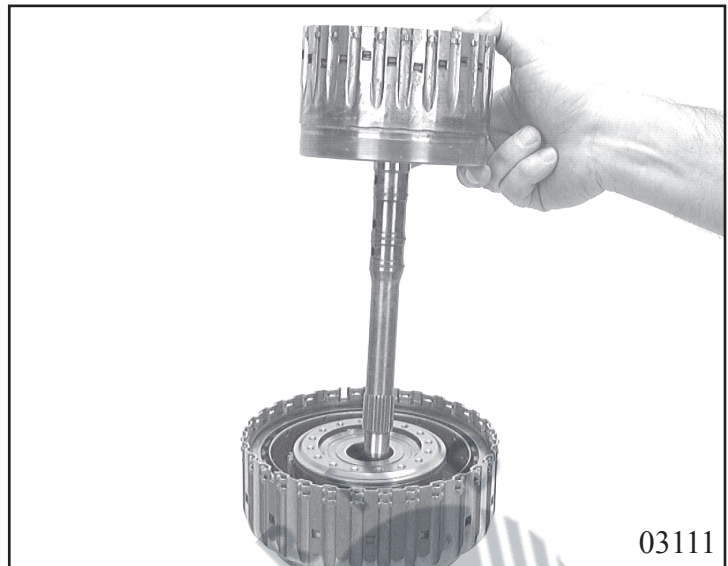

Align discs of clutches A and E and insert
intermediate shaft 71.280 by turning
slightly.
Clip axial needle roller bearing 71.290
onto hub of inner disc carrier A. Insert
sun gear shaft 71.240 by turning.

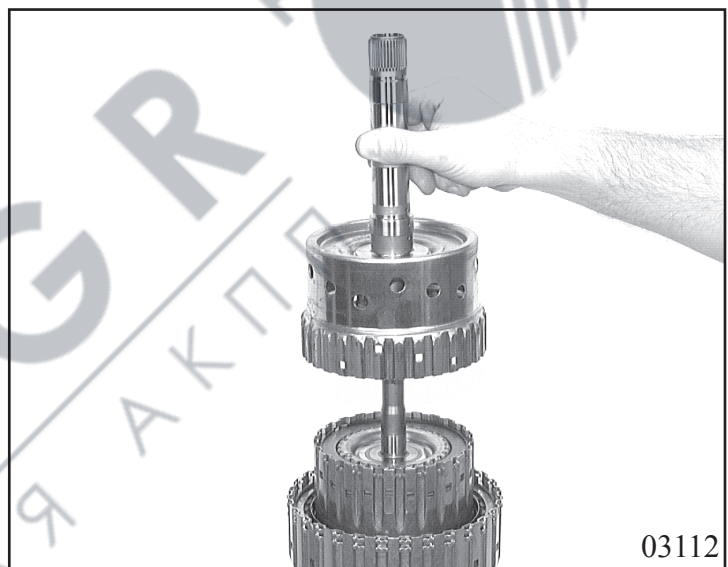

Insert inner disk carrier B 71.300 into
cylinder A and secure with snap ring
71.310.

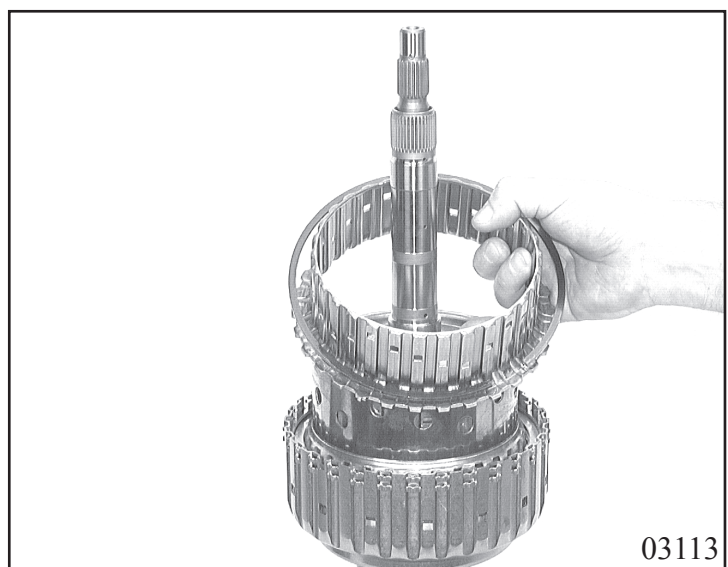

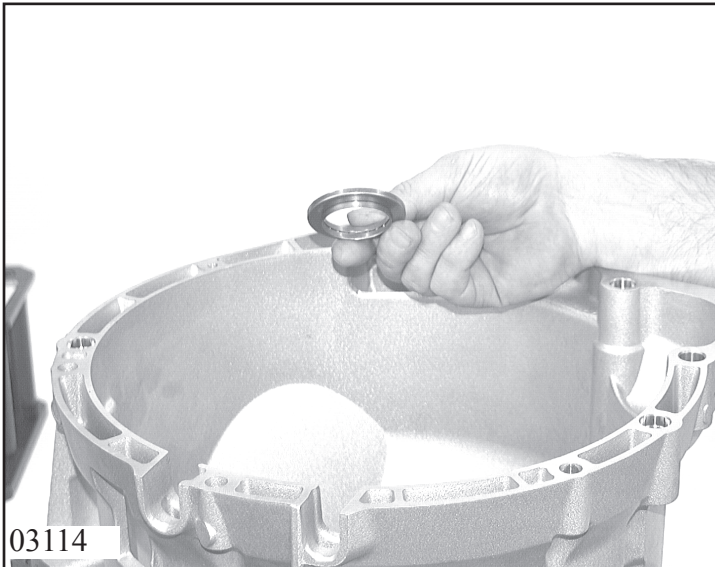

Place axial needle roller cage 72.210 with angle disk facing down on the hub of cylinder B.

03114

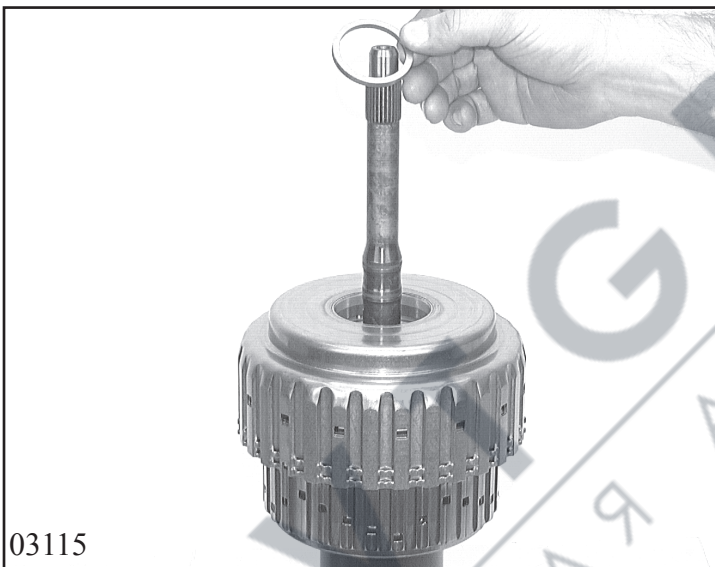

Turn the turret by 180° in the fixture. Place compensating washer 10.090 (previously removed) over the input shaft and onto cylinder A.

03115

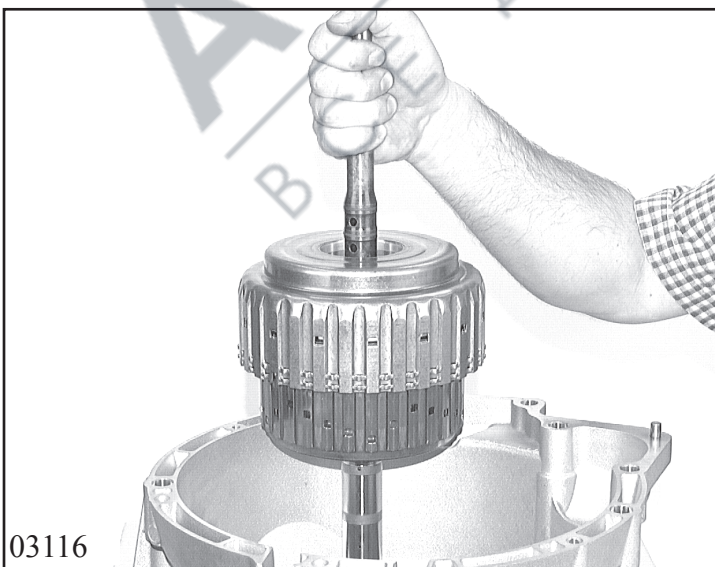

Align discs of clutch B, insert turret by hand and turn it in both directions until the discs engage fully in disc carrier B.

03116

Check measurement:

Upper edge of cylinder A to oil supply sealing face approx. 14 mm.

Note:

This measurement does not include the thickness of the measuring bar.

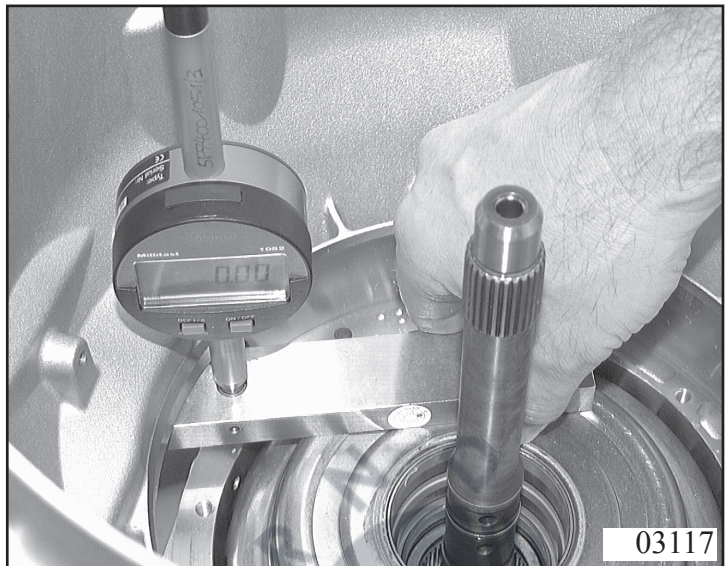

AVTGR
ВСЕ ДЛЯ АКПП

3.6 Oil supply

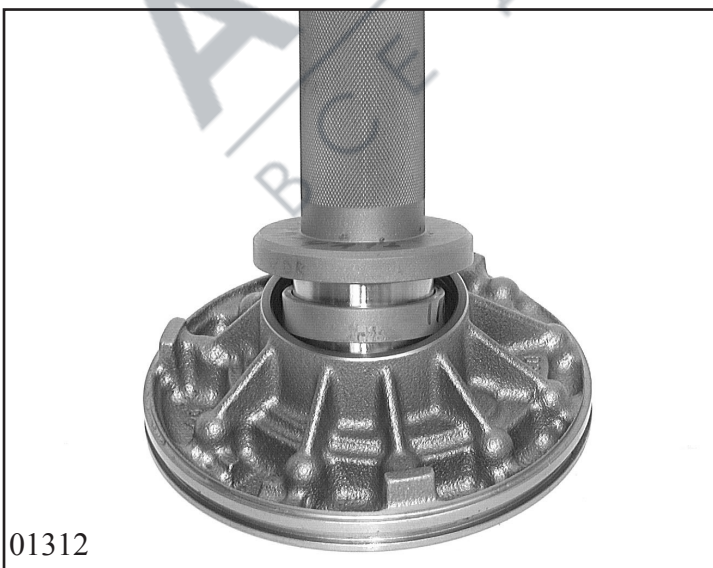
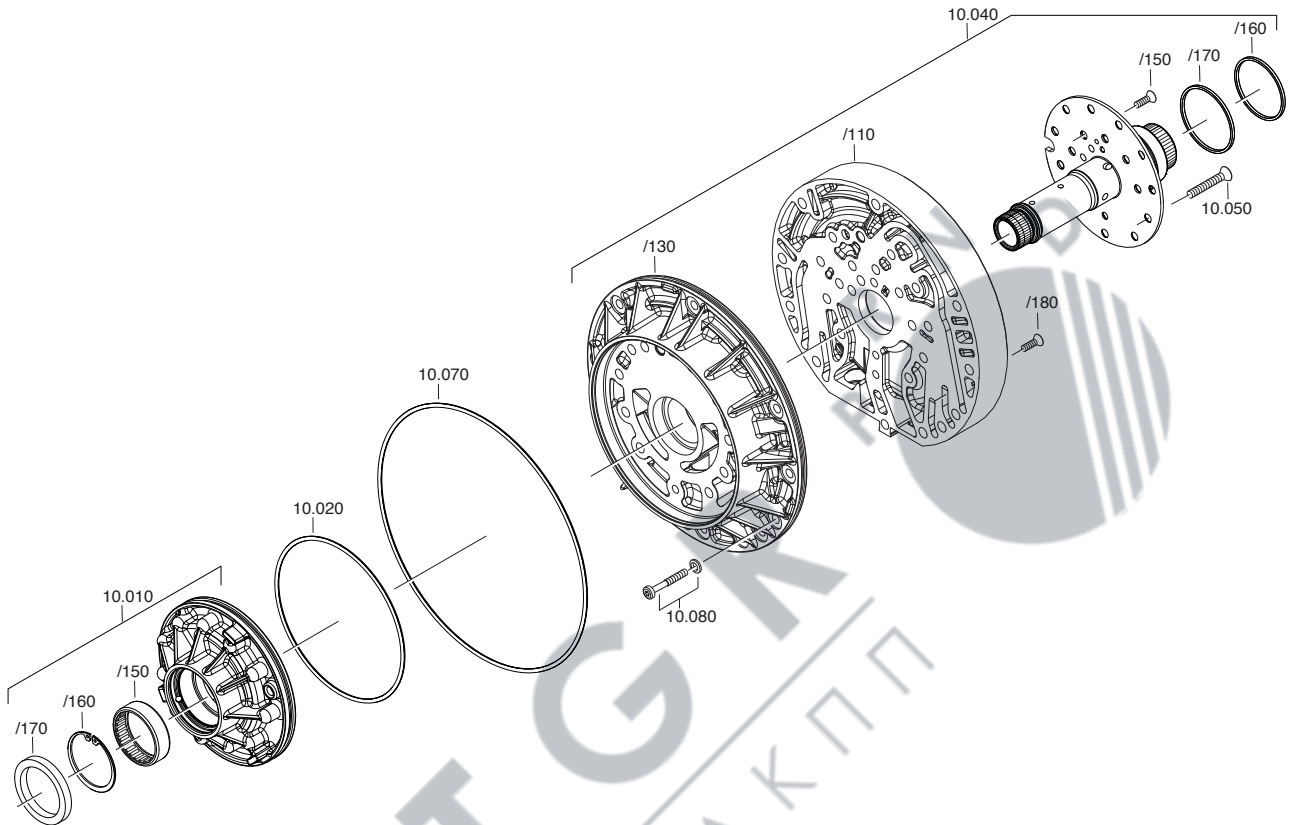

Attach all components to pump 10.010 again.

Press in needle roller bearing 10.010/150 with labelled side on top, using assembly mandrel 5x46 002 558 (with ring) in the mandrel press and secure with snap ring 10.010/160.

01312

Then fit shaft sealing ring 10.010/170 into the pump housing and press into the pump using assembly mandrel 5x46 002 558 (without ring).



Put on new O-ring seal 10.020. Lubricate the pump wheel and internal ring gear slightly before assembly. Then assemble the pump in such a way that one marking is visible on the pump wheel and the internal ring gear each.

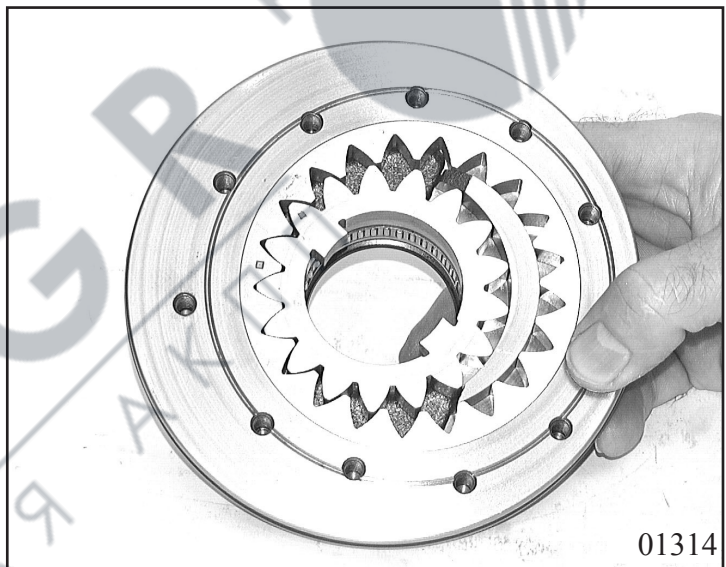

Put 2 rectangular rings 10.040/160 + /170 onto the stator shaft 10.040/140. In order to mount the stator shaft on the intermediate plate, these must be positioned towards each other. Follow the procedure stated on the next page.

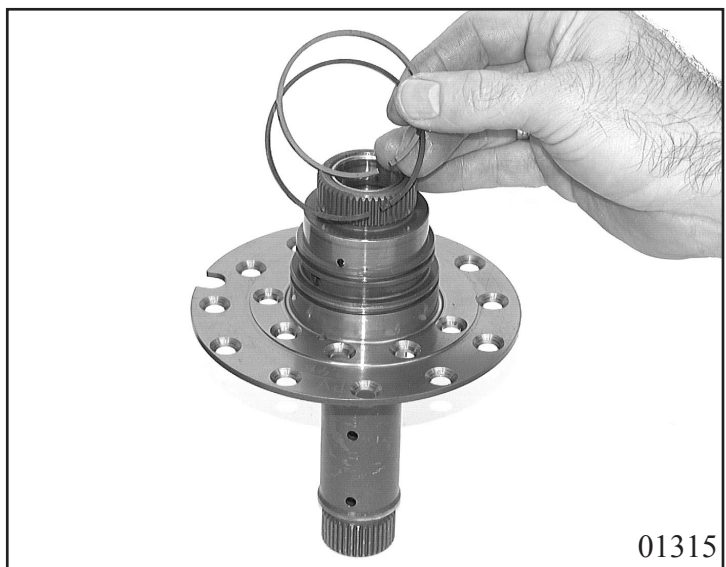

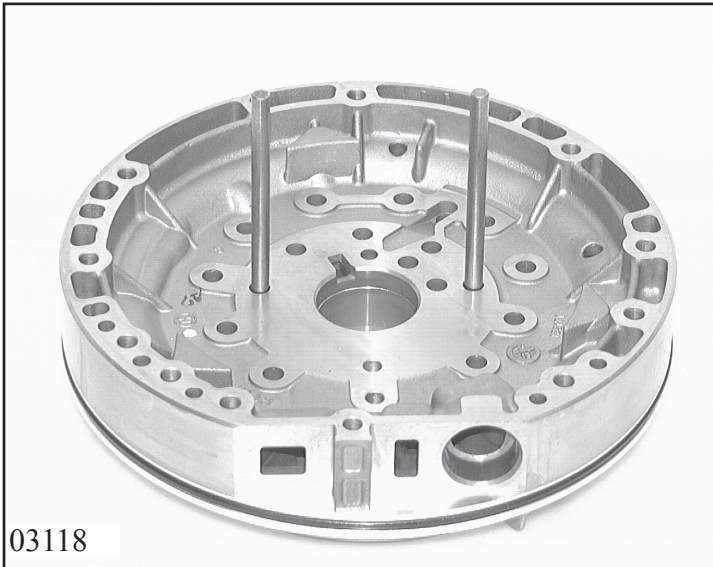

Place intermediate plate 10.040/110 onto centering plate 10.040/130 and position. Srew 2 locating pins 5x46 001 007 into centering plate.

03118

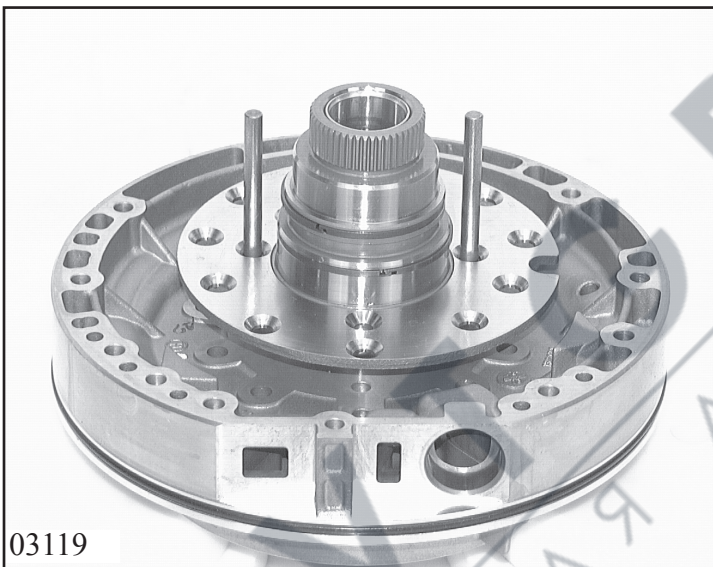

Put the intermediate and centering plates on a supporting fixture and heat up with a hot-air blower to approx. 70 °C. Insert the stator shaft over the locating pins and fasten first with 4 countersunk screws 10.040/150. Remove the locating pins, insert the remaining 2 countersunk screws and also tighten the 4 screws previously screwed in.

(For tightening torque, see **Chapter 1.5**)

03119

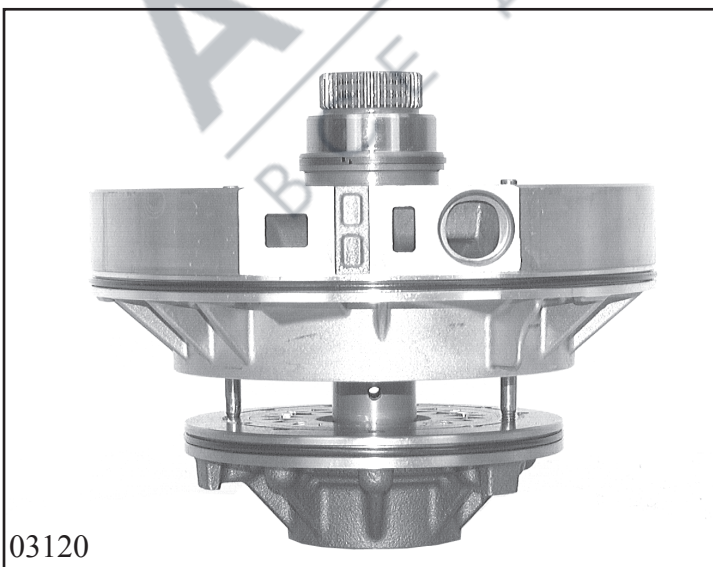

Screw locating pins 5x46 001 007 into pump. Mount complete pump over stator shaft, remove locating pins and tighten with 11 machine screws 10.050.

(For tightening torque, see **Chapter 1.5**)

03120

Note:

Check pump with sleeve 5x46 000 306 for free running. Pump wheels must rotate easily when turned.

Put on new O-ring seal 10.070.
Apply a small amount of Vaseline to the rectangular-section rings on the input shaft.
Carefully place the complete oil supply unit in the transmission casing using lifting device 5x46 002 009, align and press in.

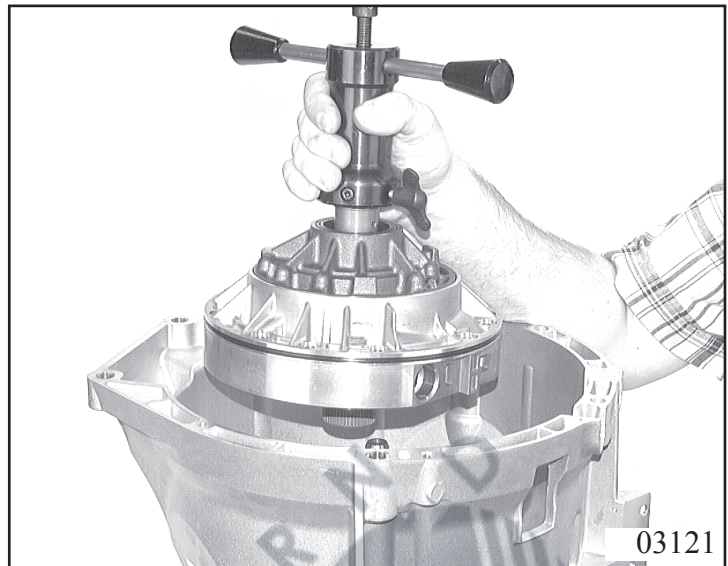

Tighten down the oil supply with 11 Torx screws 10.080 and new Usit rings as follows:

(For tightening torque, see **Chapter 1.5**)

Note:
For adjusting work, see **Chapter 1.4.7**

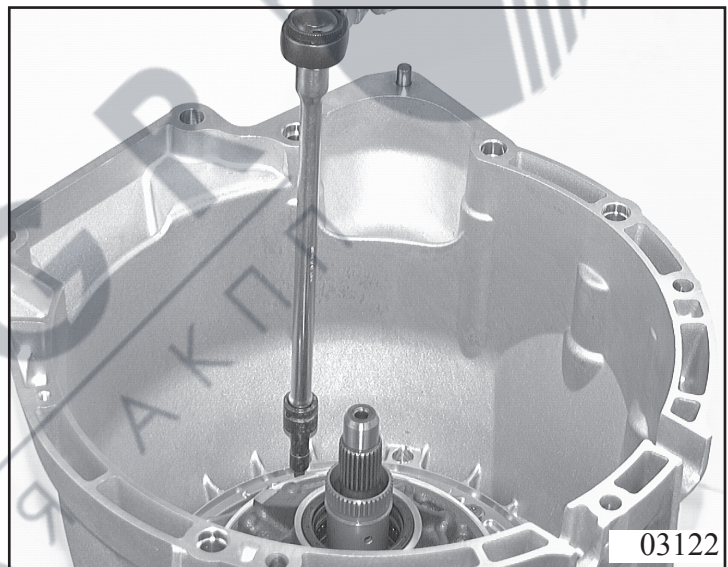

3.7 Mechatronics, oil pan and converter
 (Complete mechatronics, see spare parts list, technical cover sheet, item YO2)

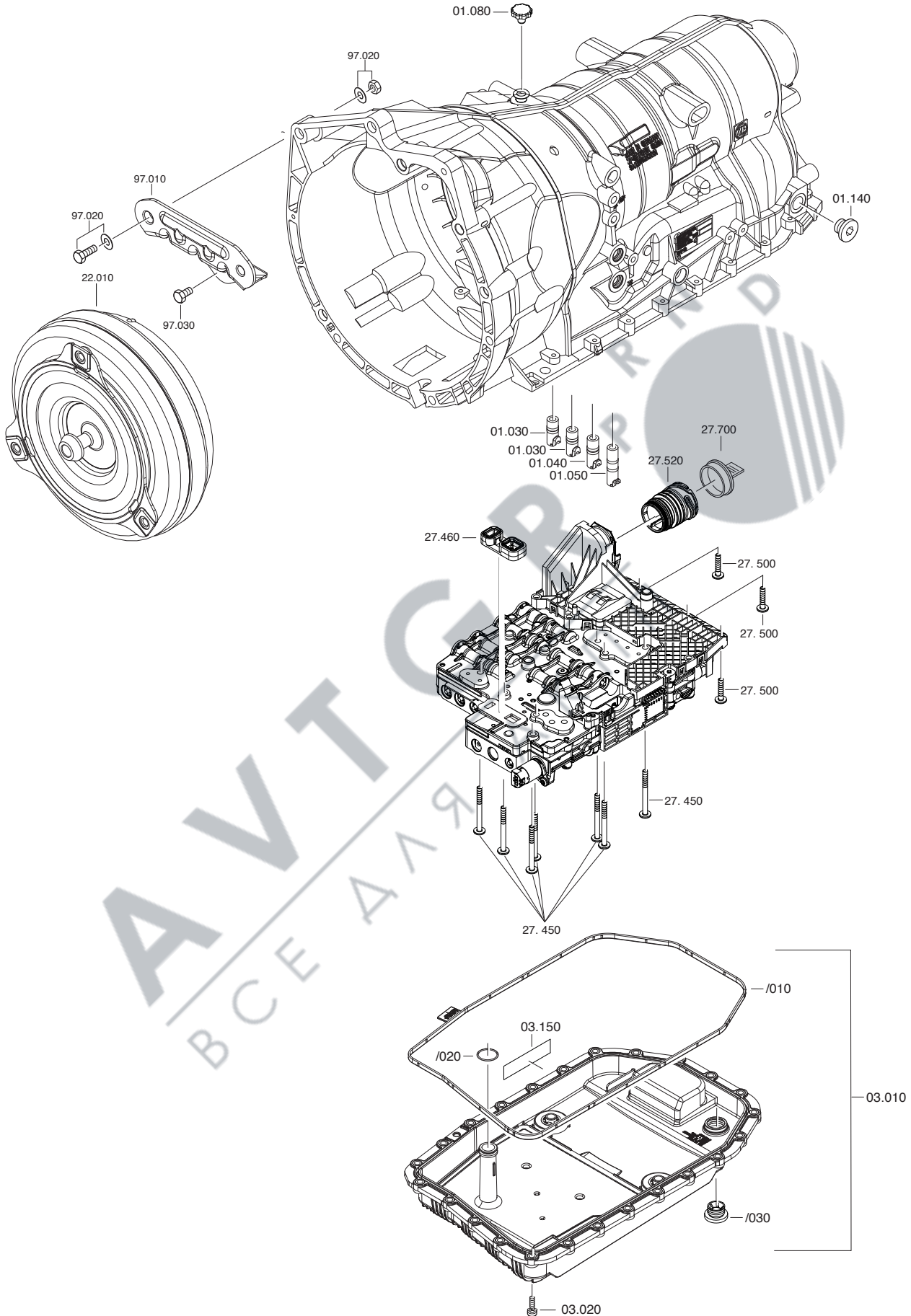

Turn the casing by 90°.
Drive in 4 sealing sleeves (2x 01.030, 01.040, 01.050) between the transmission casing and cylinder CD with a suitable tool.

Warning!

Note the correct lengths of the sealing sleeves. All of them must project by the same amount.

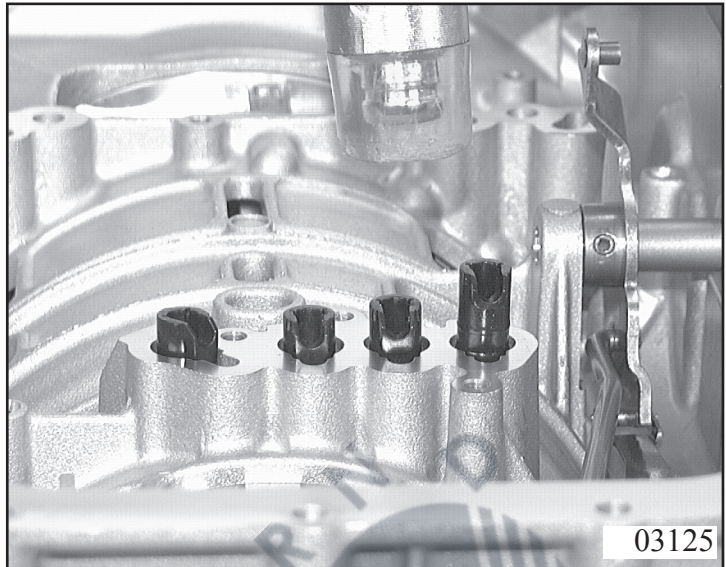

Check all clutches / brakes for proper function by supplying compressed air to the marked bores (see picture alongside)

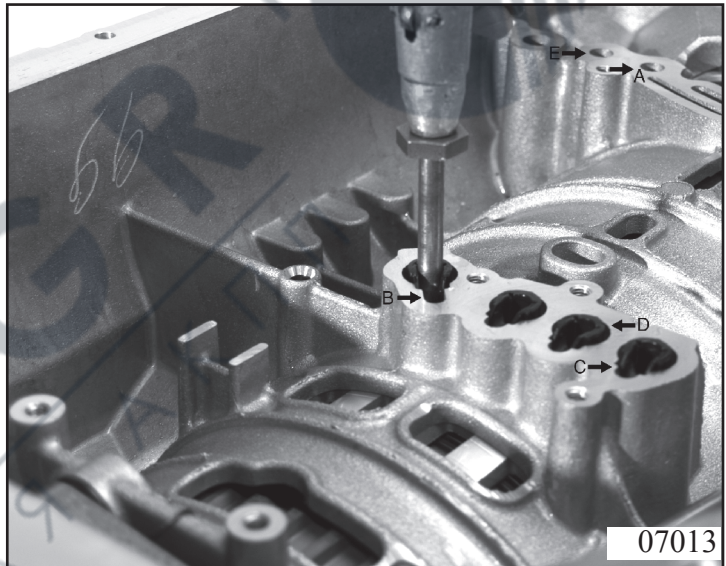

Insert adapter 27.460 into the gearbox-housing.

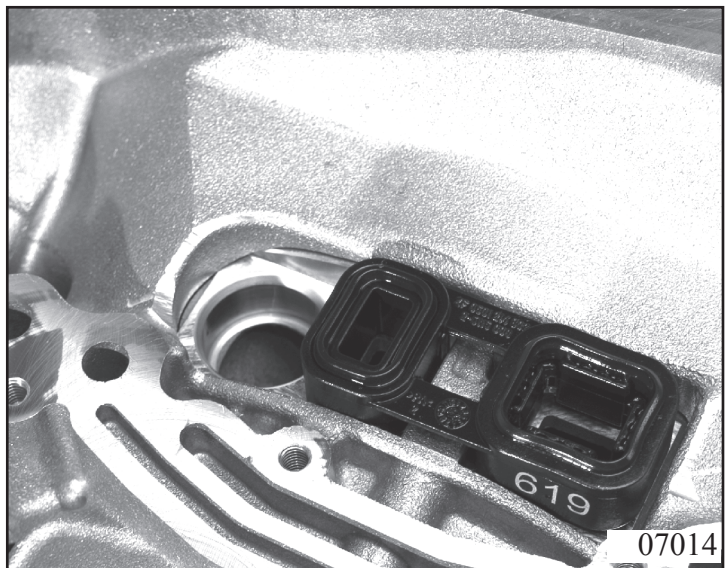

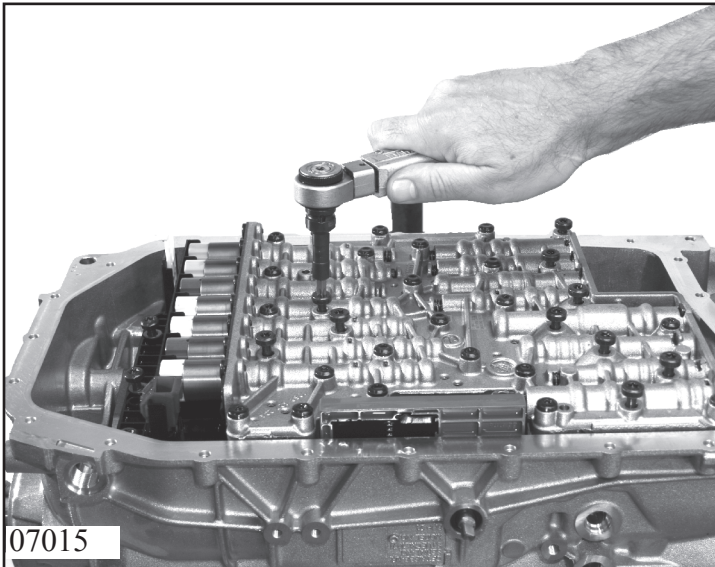

Place mechatronic.
 Attach parking or detent disk at groove in piston rod.
 Align mechatronic, press on by hand and fasten with 10 machine screws 27.450 and 3 machine screws 27.500.

For tightening torque, see **Chapter 1.5)**

Note:
 For screw specifications, see **Chapter 1.3.1**

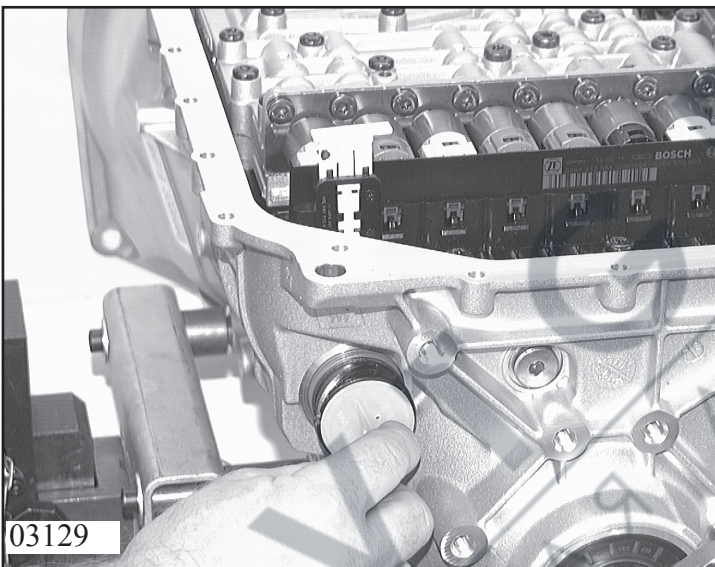

Press in new socket 27.520 with mechatronic screw plug 27.700 attached and secure with retaining clip.

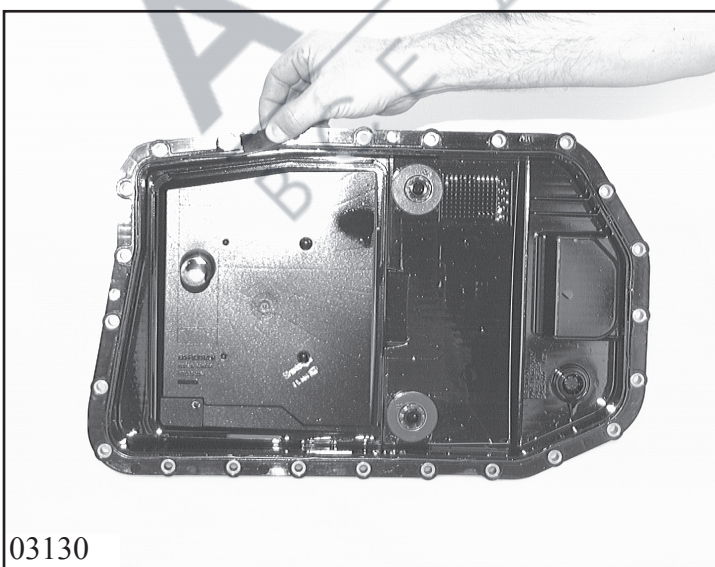

Put new O-ring seal 03.010/020 onto stub pipe of oil filter 03.010. Press new seal 03.010/014 into oil pan 03.010.

Install oil pan 03.010 and fasten with 24 machine screws 03.020.

Note:

For screw specifications, see **Chapter 1.3.1**

(For tightening torque, see **Chapter 1.5**)

Warning!

For BMW cars a label 03.150 (oil filling) must be attached to the oil pan.

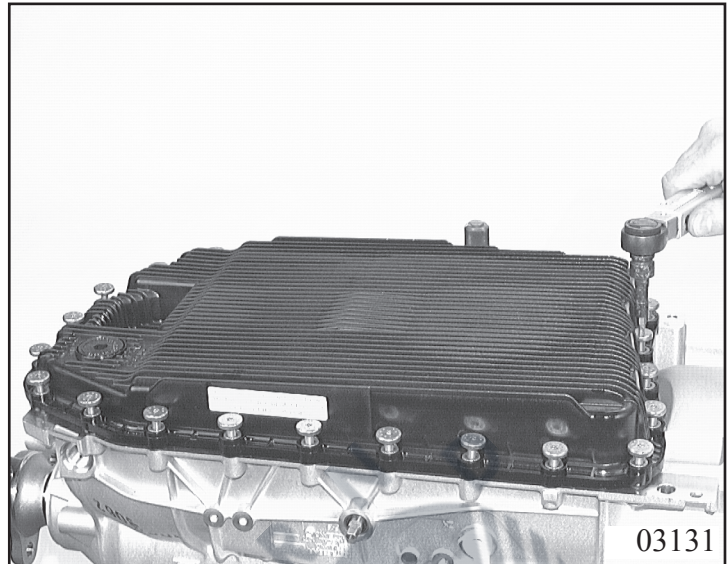

Insert 2 new screw plugs (oil fill) 01.140 into gearbox-housing.

(For tightening torque, see **Chapter 1.5**)

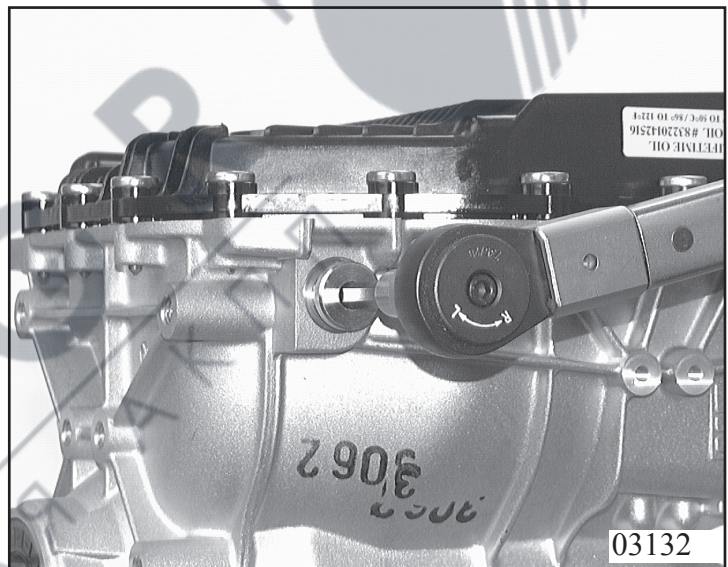

Screw in both converter handles 5x56 000 090 and carefully insert converter 22.010.

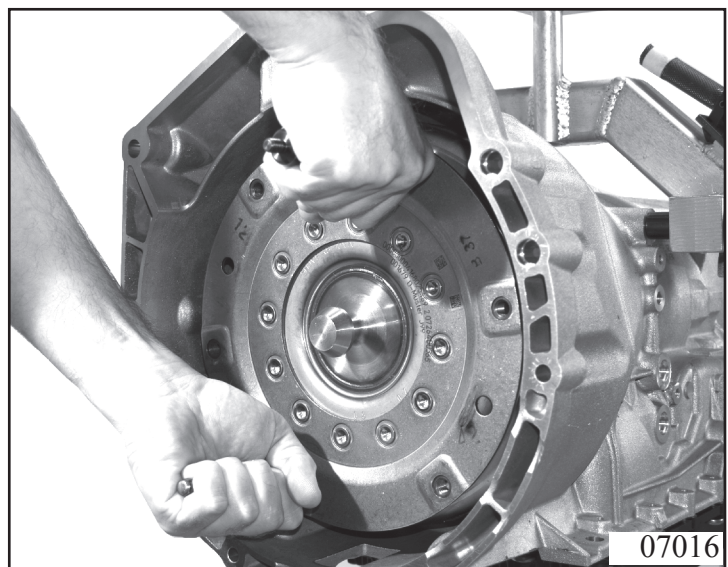

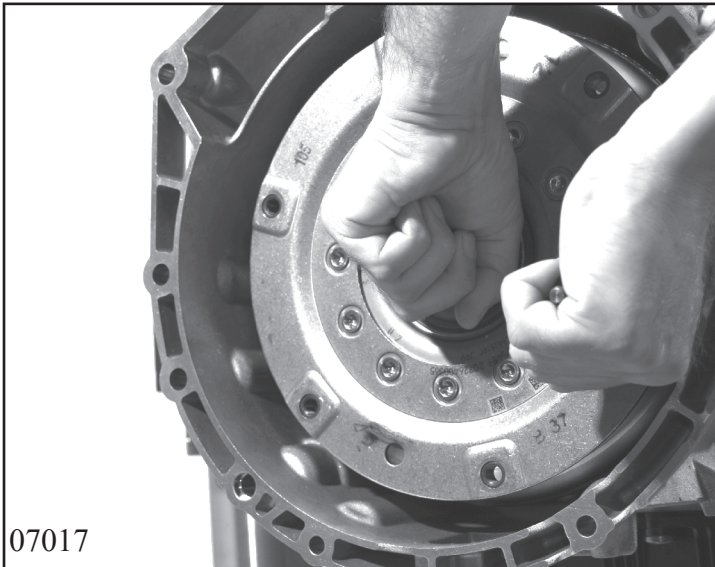

Move converter back and forward until the pump drive pins engage.

Warning!

When inserting, make sure that the drive pins are not damaged.

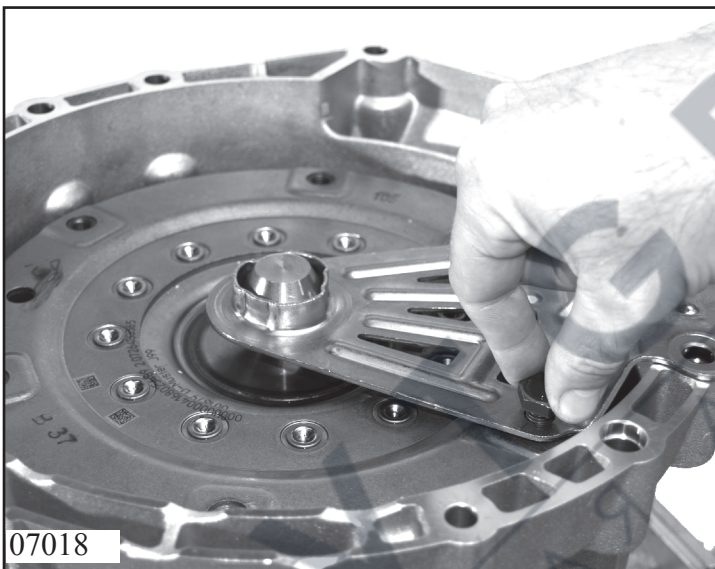

Remove converter handles.
Turn transmission by 90°
Screw on converter retaining bracket 97.010 with 1 screw and nut 97.020 on gearboxhousing and 1 screw 97.030 on converter.

For tightening torque, see **Chapter 1.5)**

References to possible *mechatronic functional tests* can be found in the relevant trouble-shooting program.

Attach breather cover 01.080 to breather.

Attach the remaining transport plug:

-possibly 1 plug at selector shaft 06.050

Note!

Right-hand-drive cars have 2 plugs at the selector shaft.

