

# REPAIR MANUAL

**6 HP-28**



**ZF GETRIEBE GMBH SAARBRÜCKEN**

Version 07/12/01  
CD



subject to alterations

© Copyright 2008 all rights reserved and published by  
ZF Getriebe GmbH, Saarbrücken, Department MKTD

No part of this manual may be reproduced or transmitted in any form or  
by any means, electronic or mechanical, including photocopying and recording,  
for any purpose without the express written permission of  
ZF Getriebe GmbH, Saarbrücken

Printed in Germany

# Contents

Advance Information		iii
1. General		1.1/1
1.1 Illustration of transmission		1.1/1
1.2 Power flow diagram		1.2/1
1.3 Specifications		1.3/1
1.3.1 Screw specifications		1.3/1
1.3.1.1 Mechatronic type E		1.3/1
1.3.1.2 Mechatronic type M		1.3/1
1.3.1.3 Oil sump		1.3/1
1.4 Adjusting procedure		1.4/1
1.4.0 Measuring clutch packs	(procedure)	1.4/1
1.4.1 Clearance setting, brake C	(snap ring)	1.4/3
1.4.2 Clearance setting, brake D	(snap ring)	1.4/5
1.4.3 Clearance setting, clutch B	(snap ring)	1.4/7
1.4.4 Clearance setting, clutch A	(snap ring)	1.4/9
1.4.5 Clearance setting, clutch E	(snap ring)	1.4/11
1.4.6 Clearance - output	(disk)	1.4/13
1.4.7 Clearance - input	(disk)	1.4/14
(M type only)		
1.4.8 Switch setting	(detent spring)	1.4/15
1.5 Tightening torques		1.5/1
1.6 Transmission test (test bench)		1.6/1
1.7 Special tools		1.7/1
1.8 Oilflow chart (Position N)		1.8/1
(E - type)		1.8/1
(M - type)		1.8/2
2. Disassembly		2.1/1
2.1 Transmission disassembly according to component groups		2.1/1
Dismantling		
2.2 Turret (with clutches A and E)		2.2/1
2.3 Oil supply		2.3/1
2.4 Clutch B		2.4/1
2.5 Brakes C and D		2.5/1
2.6 Output shaft with parking lock		2.6/1
2.7 Transmission casing with shift-control and parking lock		2.7/1
3. Assembly		3.1/1
3.1 Transmission casing with shift control and parking lock		3.1/1
3.2 Output shaft with parking lock and planetary gear set		3.2/1
3.3 Brakes C and D		3.3/1
3.4 Clutch B		3.4/1
3.5 Turret (drive with clutches A and E)		3.5/1
3.5.1 Clutch E (drive)		3.5/1
3.5.2 Clutch A (input)		3.5/4
3.6 Oil supply		3.6/1
3.7 Mechatronics, oil pan and converter		3.7/1
(Complete mechatronics, see spare parts list, technical cover sheet, item YO2)		



# Advance Information

These instructions contain the procedure for repair work on the complete transmission.

The repair instructions will only be understood sufficiently in combination with ZFS training. Neglecting this could lead to installation errors.

All disassembly and assembly work is listed in chronological order.

Photos and illustrations for the various applications are general in character and not binding for every individual case.

Important changes and those relevant to specific applications that have to be considered during repair work are announced in *service bulletins* and training courses.

During the repair work SDM regulations and serviceline-specifications must be observed.

Please note the following:

- Seals, e.g. O-rings, shaft sealing rings, gaskets and filters must always be renewed.
- During assembly, all O-rings, cylindrical rings and other sealing rings must be greased with Vaseline before mounting.
- All bearings must be slightly oiled when installed.
- Exchange all lining and steel disks in transmissions with higher distance readings (> 80,000 kilometers / 50,000 miles).
- After clutch / brake damage, converters, oil pipes and oil coolers must be cleaned out thoroughly and sufficiently with an appropriate cleaning agent.

The following requirements should be satisfied before starting the repair work:

- Availability of the necessary special tools otherwise assembly faults are possible. Chapter 1.7 lists the complete set of special tools.
- Availability of a suitable transmission test rig. For the necessary test values, please refer to the *Technical Circular Letters*.

**Note:**

In the instructions the shift control unit is considered as a complete unit. It must not be dismantled without special experience, but should be exchanged as a complete unit.

It is planned to issue separate instructions for the control unit.

**Warning:**

The transmission is filled for life with oil.

**An oil change is not necessary before 160 000 km or 10 years.**

Make sure that the transmission is delivered with the oil quantity and oil type specified in the relevant part list document (see SDM).

Techn. KD

Techn. Documentation

KD Training

Dr. Gratz

Reus

Haben

1. General  
1.1 Illustration of transmission

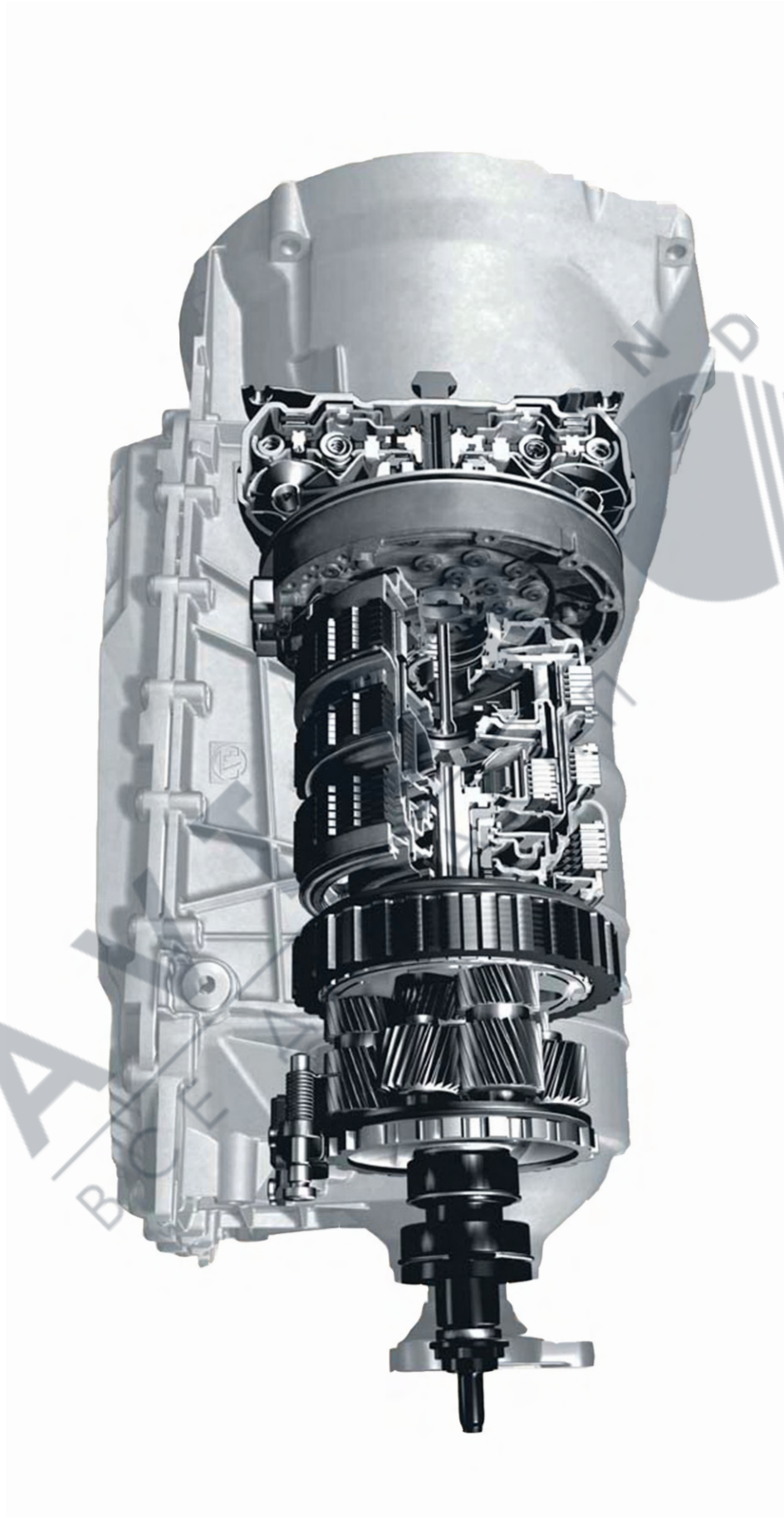





## 1.2 Power flow diagram

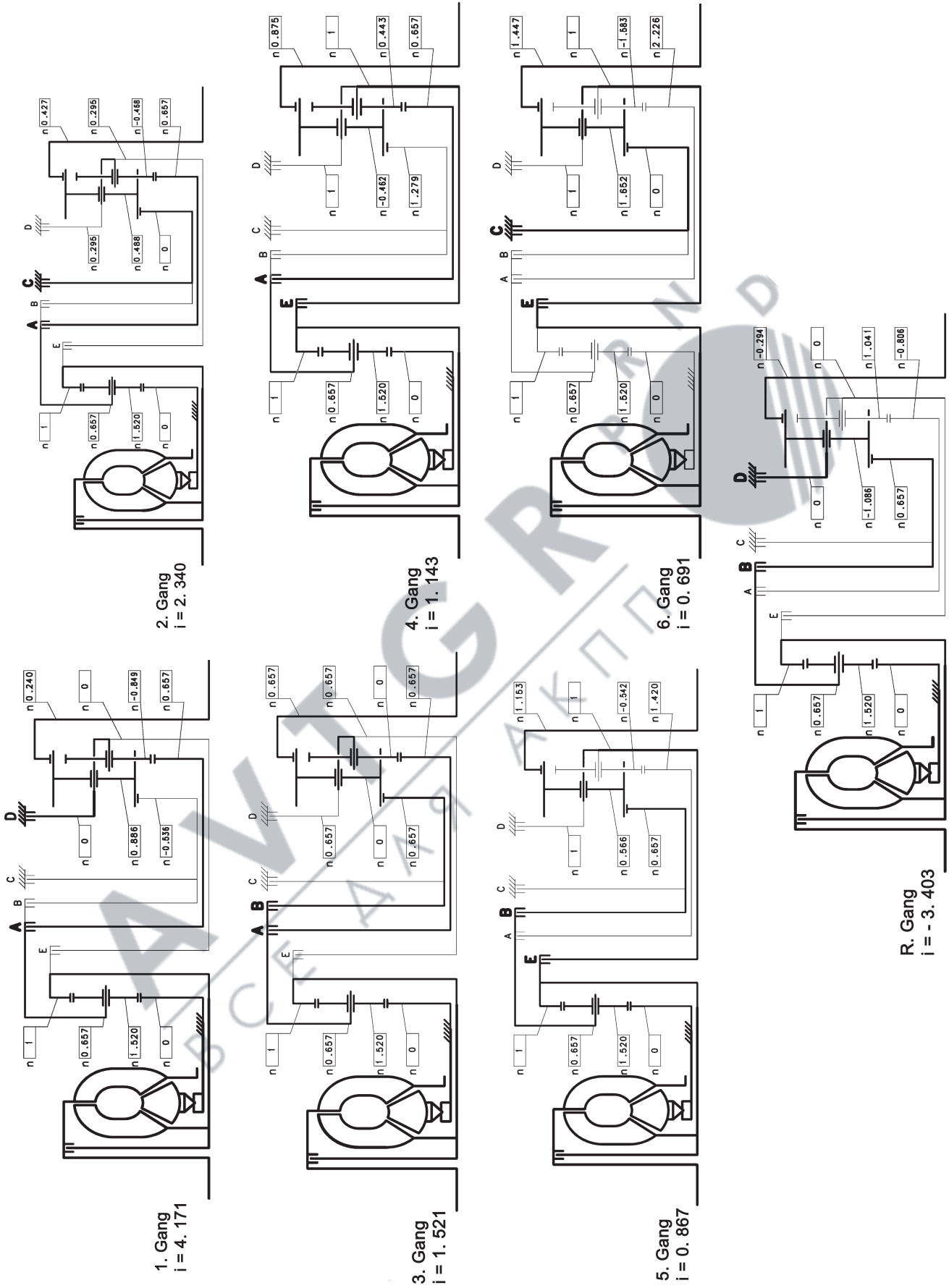



### 1.3 Specifications

#### 1.3.1 Screw specifications

##### 1.3.1.1 Mechatronic type E

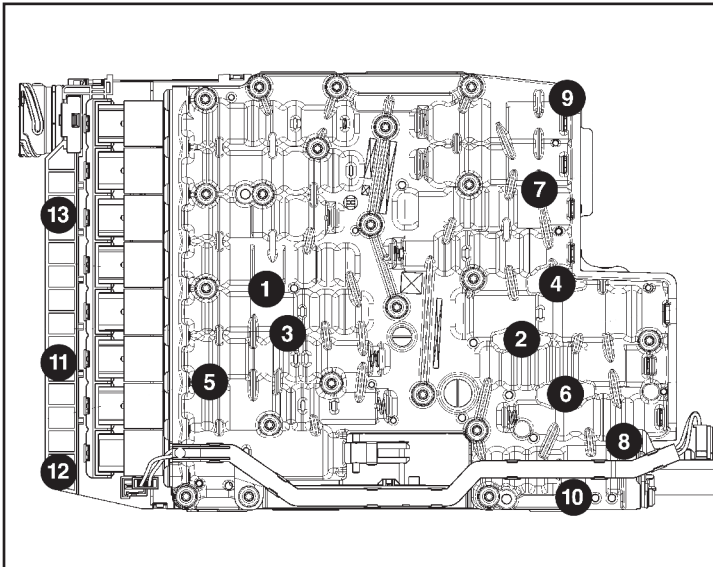

Tighten screws of the type E mechatronic in the order of the numbering (see diagram)

1 ⇔ 2 ⇔ 3 ⇔ ... ⇔ 13

**Important!**

**Specification 1068 700 240**

(Tightening torque: see Chapter 1.5)

##### 1.3.1.2 Mechatronic type M

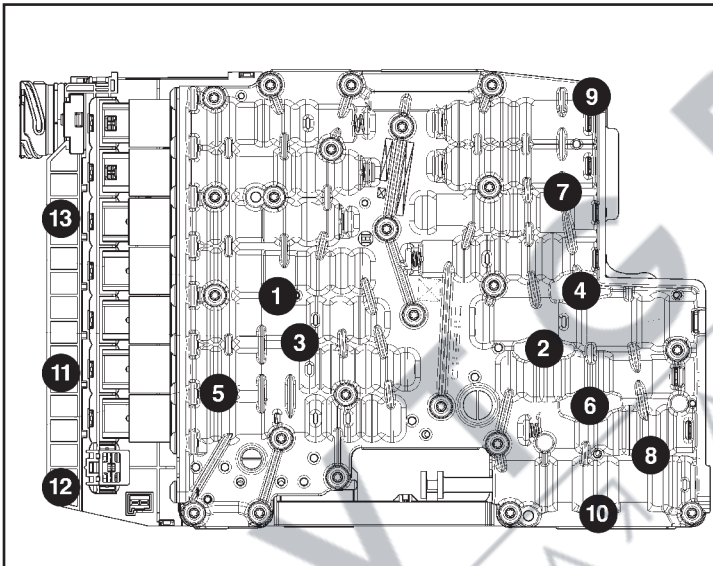

Tighten screws of the type M mechatronic in the order of the numbering (see diagram)

1 ⇔ 2 ⇔ 3 ⇔ ... ⇔ 13

**Important!**

**Specification 1068 700 240**

(Tightening torque: see Chapter 1.5)

##### 1.3.1.3 Oil sump

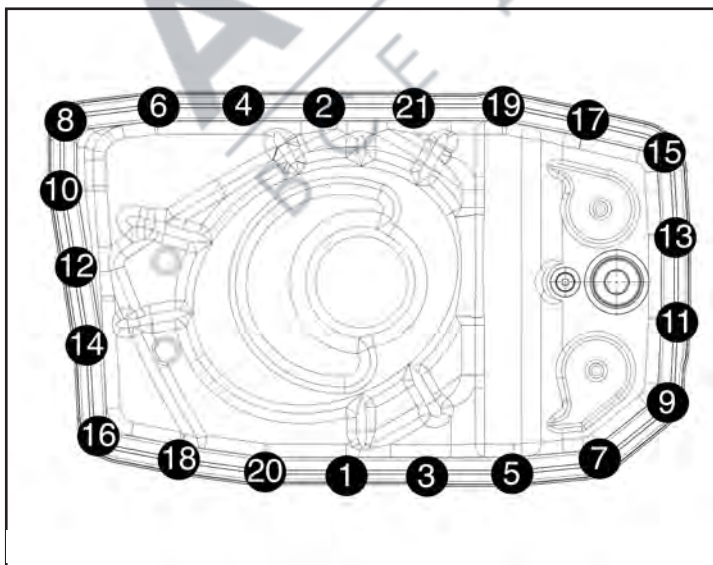

Tighten screws of oil sump in the order of the numbering (see diagram)

1 ⇔ 2 ⇔ 3 ⇔ ... ⇔ 21

(Tightening torque: see Chapter 1.5)



## 1.4 Adjusting procedure

### 1.4.0 Measuring clutch packs (procedure)

Place the two intermediate pieces 5p01 050 329/5p01 060 329 on the marked position on measuring fixture 5p01 000 330.

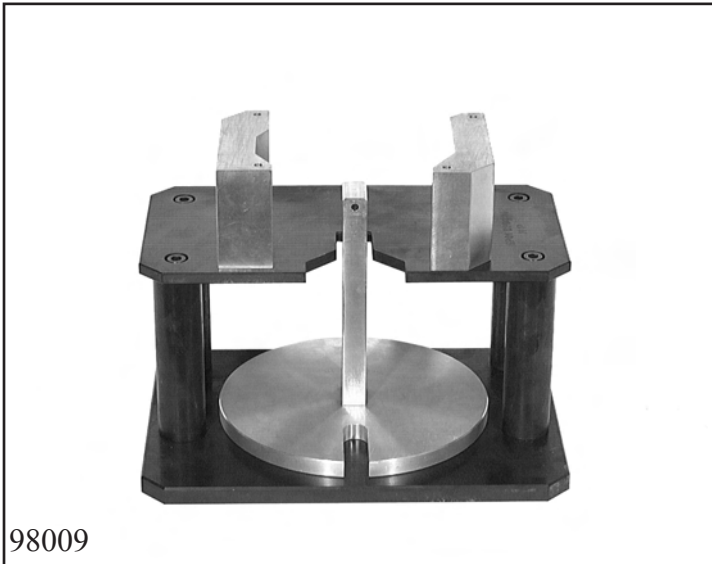

Using the knurled screw, turn adjusting device 5p01 001 458 to the upper limit.

Attach force measuring unit 5p01 000 329 to adjusting device.



Fasten it with 4 knurled screws to the measuring fixture using the intermediate pieces.

Using a fixing pin, connect measuring plate 5p01 040 330 with the force measuring unit.

Using the knurled screw, clamp the clutch pack to be measured (with steel disc on the top and corrugated disc if there is one on the bottom) in the device at 200N.

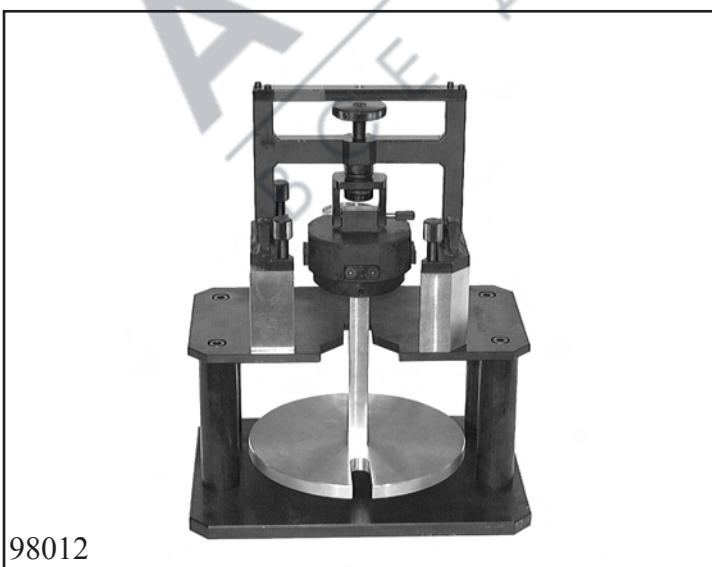

Check the value on the force measuring unit's display.

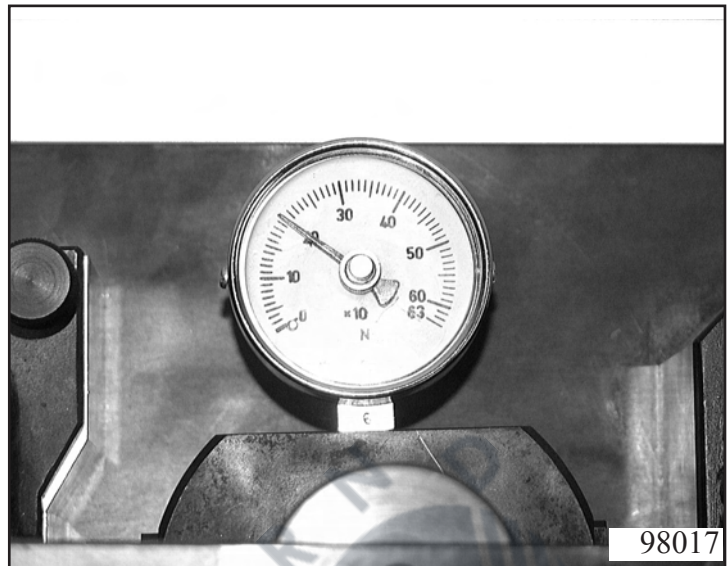

Then place measuring bar 5p01 060 330 on the measuring plate, put the dial gauge's measuring base in the measuring plate's groove on the top disc of the set, and set the dial gauge to 0.

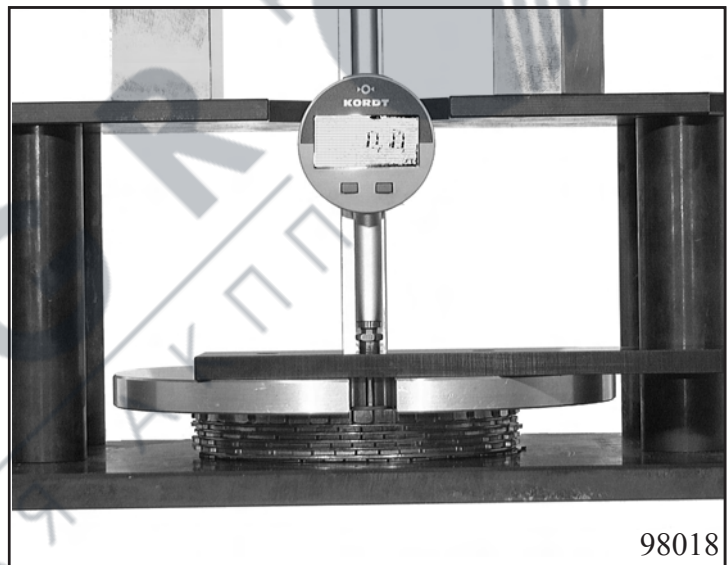

Now use the measuring bar to measure down to the base plate.

Read the measurement value  $\Leftrightarrow M_X$

**Note!**

In each case, the **X** index in  $M_X$  stands for the brake/ clutch packs that are put in (A, B, C, D, E).

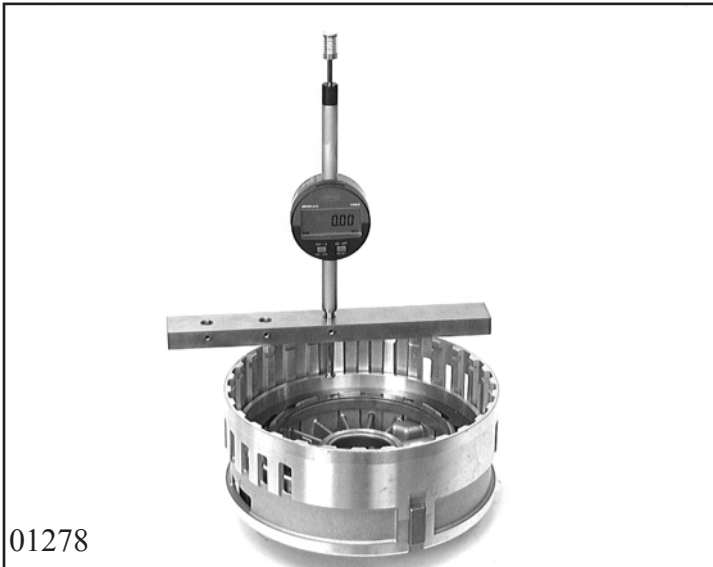

01278

#### 1.4.1 Clearance setting, brake C (snap ring)

Determine space requirement  $E_C$  for brake C with measuring bar 5p01 000 330.

To do this, place measuring bar 5p01 000 330 on cylinder edge of brake C.

Place measuring base on the topmost point on the disk supporting area at the piston and set dial gauge to "0".

Pull measuring sensor upwards, insert into snap ring groove and press against the top edge of the groove.

Read measured value off at dial gauge  $\Rightarrow W_C$

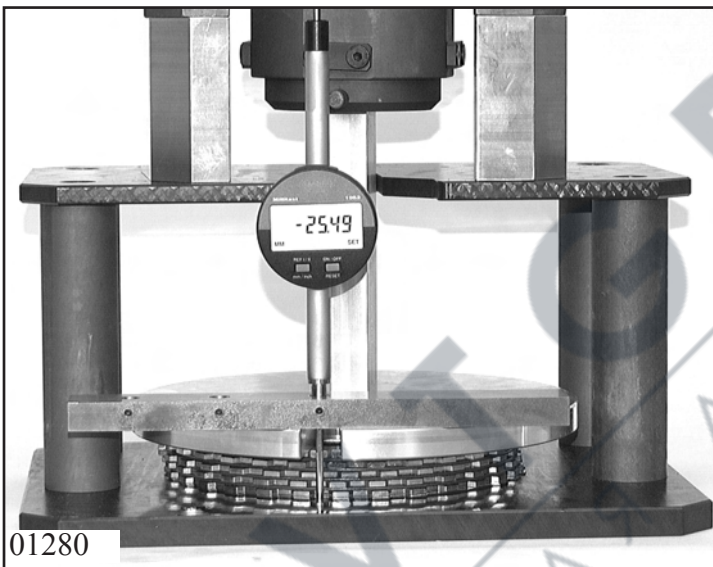

01280

Determine thickness  $M_C$  of brake C clutch pack according to **Chapter 1.4.0 Measuring clutch pack.**

$\Rightarrow M_C$

Space requirement  $E_C$  is determined from measured value  $W_C$  plus base thickness  $F$ .  $\Rightarrow E_C$

Test value  $P_C$  is determined from space requirements  $E_C$  minus  $M_C$ .

Value  $P_C$  should be between 4.66 and 6.15 mm.

**Testing specification 1068 700 261.**  
Version A

Select snap ring  $S_C$  with test value  $P_C$ .

**Calculation:**

$$E_C = W_C + F$$

$$P_C = E_C - M_C$$

Clearance  $L_C$  with 5 lining disks should be between 1.56 - 2.05 mm.

**Example (for 1.4.1):**

$$F = 1.48 \text{ mm (base thickness)}$$

$$W_C = 29.05 \text{ mm}$$

$$M_C = 25.49 \text{ mm}$$

$$E_C = 29.05 + 1.48$$

$$= 30.53 \text{ mm}$$

$$P_C = 30.53 - 25.49$$

$$= 5.04 \text{ mm}$$

$$S_C = 3.36 \text{ mm}$$

$$L_C = 5.04 - 3.36$$

$$\Rightarrow L_C = 1.68 \text{ mm}$$





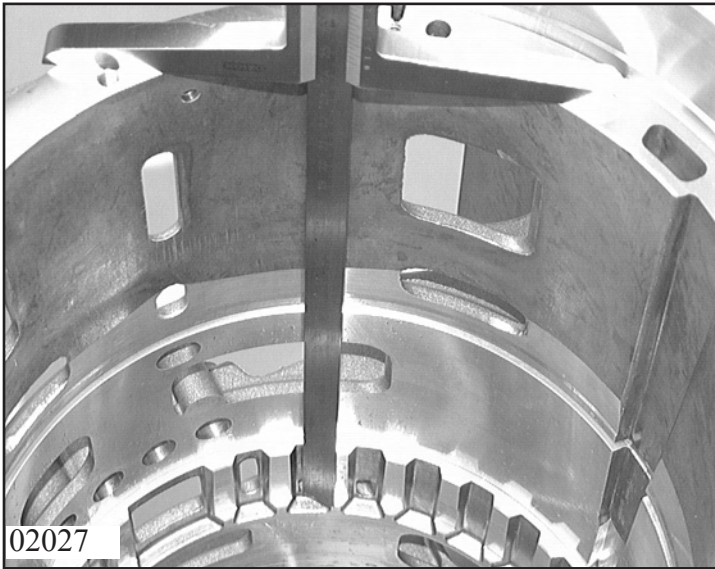

02027

#### 1.4.2 Clearance setting, brake D (snap ring)

Determine space requirement  $E_D$  of brake D with depth gauge.  
 To do this, place depth gauge on oil supply sealing face.  
 Place measuring base on lowest point of the disk support area in the housing and read off dimension  $\Leftrightarrow W_{DA}$ .



01271

Place measuring base on cylinder support area CD in the housing and read off dimension  $\Leftrightarrow W_{DB}$ .

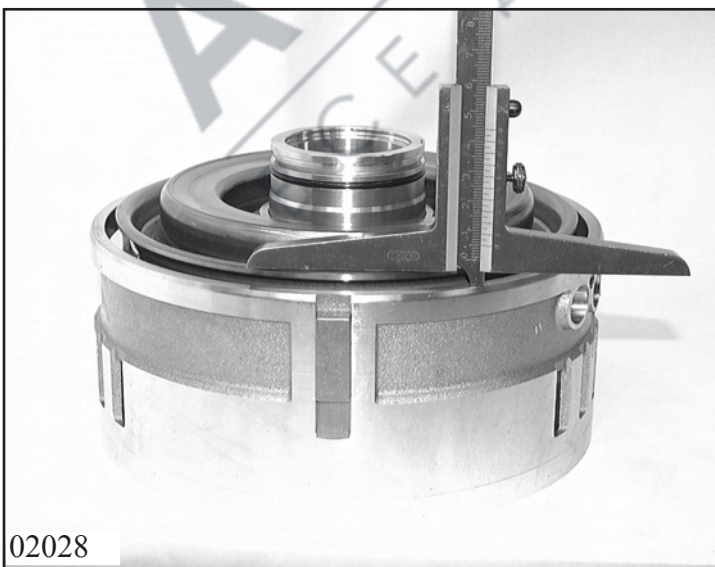

02028

Measure down from piston to cylinder support area CD and read off dimension  $\Leftrightarrow M_{DB}$ .

Determine thickness  $M_{DA}$  of brake D clutch pack D excluding final disk according to **Chapter 1.4.0 Measuring clutch pack**.

$M_{DA}$

Space requirement  $E_D$  and clutch pack thickness/ test value  $P_D$  result from:

$$\Leftrightarrow E_D = W_{DA} - W_{DB}$$

$$\Leftrightarrow P_D = M_{DA} + M_{DB}$$

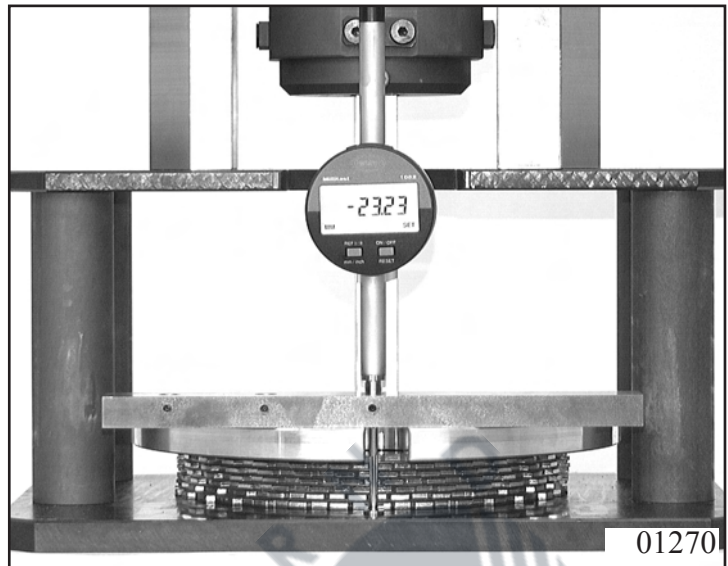

Value  $P_D$  should be between 27.79 and 29.29 mm.

**Testing specification 1068 700 216**  
Version *B*

Select snap ring  $S_D$  with test value  $P_D$ .

Clearance  $L_D$  with 6 lining disks should be between 1.77 and 2.40 mm.

**Example (for 1.4.2):**

$$W_{DA} = 247.9 \text{ mm}$$

$$W_{DB} = 214.5 \text{ mm}$$

$$M_{DA} = 23.23 \text{ mm}$$

$$M_{DB} = 4.8 \text{ mm}$$

$$E_D = 247.9 - 214.7$$

$$= 33.2 \text{ mm}$$

$$P_D = 23.23 + 4.8$$

$$= 28.03 \text{ mm}$$

$$S_D = 3.2 \text{ mm}$$

$$L_D = 33.2 - 28.03 - 3.2$$

$$\Leftrightarrow L_D = 1.97 \text{ mm}$$



08021

### 1.4.3 Clearance setting, clutch B (snap ring)

Determine space requirement  $E_B$  for clutch B with measuring bar 5p01 000 330.

For this purpose, place measuring bar 5p01 000 330 on cylinder edge of clutch B. Place measuring base on highest point of disk support area at the piston and set dial gauge to "0".

Pull measuring sensor upwards, insert into snap ring groove and press against the upper edge of the groove.

Read off measured value from dial gauge  $\Rightarrow W_B$

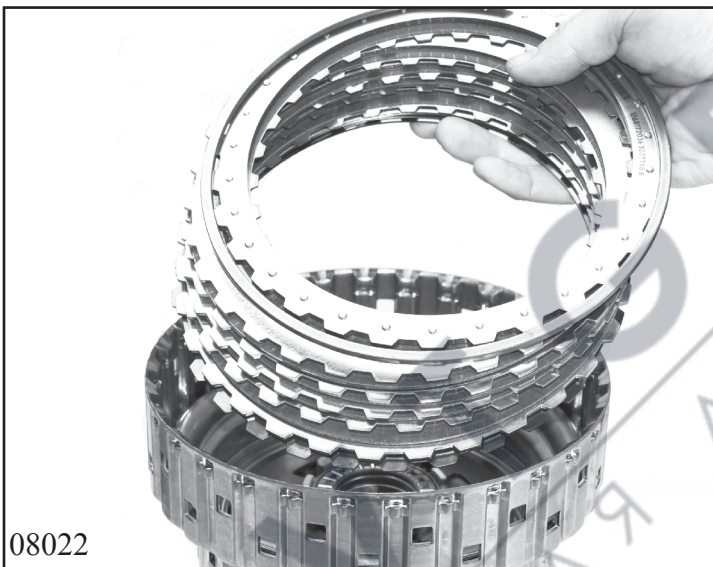

08022

Determine thickness  $M_B$  of clutch B clutch pack according to **Chapter 1.4.0 Measuring clutch pack.**

$\Rightarrow M_B$

Space requirement  $E_C$  results from measured value  $W_B$  plus base thickness  $F$ .  $\Rightarrow E_B$

Test value  $P_B$  is therefore space requirement  $E_B$  minus  $M_B$ .

Value  $P_B$  should be between 4.28 and 5.88 mm.

**Testing specification 1068 700 167**  
Version *B*

Select snap ring  $S_B$  with test value  $P_B$ .

**Calculation:**

$$E_B = W_B + F$$

$$P_B = E_B - M_B$$

Clearance  $L_B$  with 4 lining disks should be between 1.26 and 1.74 mm.

**Example (for 1.4.3):**

$$F = 1.48 \text{ mm (base thickness)}$$

$$W_B = 25.8 \text{ mm}$$

$$M_B = - 21.92 \text{ mm}$$

$$E_B = 25.8 + 1.48$$

$$= 27.28 \text{ mm}$$

$$P_B = 27.28 - 21.92$$

$$= 5.36 \text{ mm}$$

$$S_B = 4.0 \text{ mm}$$

$$L_B = 5.36 \text{ mm} - 4.0 \text{ mm}$$

$$\Rightarrow L_B = 1.36 \text{ mm}$$



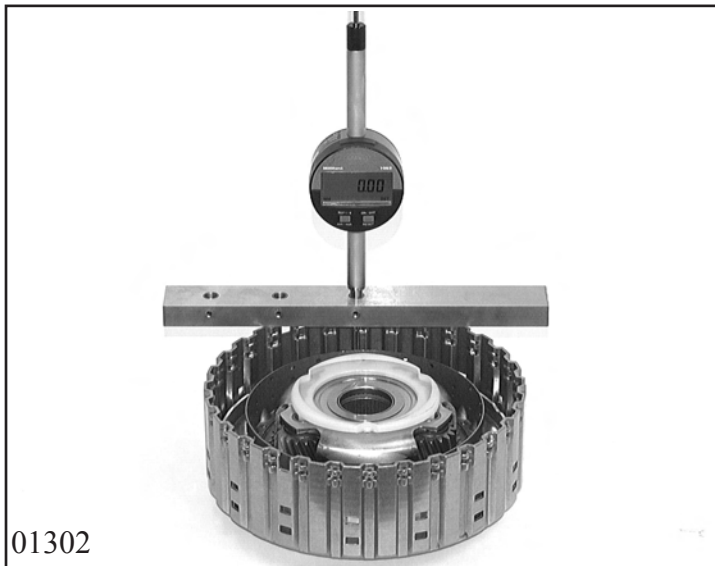

#### 1.4.4 Clearance setting, clutch A (snap ring)

Determine space requirement  $E_A$  of clutch A with measuring bar 5p01 000 330.

For this purpose, place measuring bar 5p01 000 330 on cylinder edge of clutch A. Place measuring base on highest point of disk support area at the piston and set dial gauge to "0".

Pull measuring sensor upwards, insert into snap ring groove and press against the upper edge of the groove.

Read off measured value from dial gauge  $\Rightarrow W_A$

01302

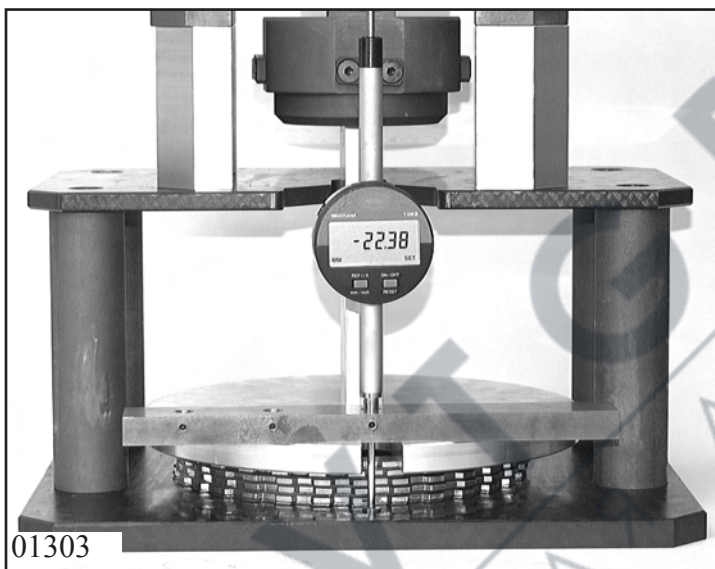

Determine thickness  $M_A$  of clutch A clutch pack according to **Chapter 1.4.0 Measuring clutch pack.**

$\Rightarrow M_A$

Space requirement  $E_A$  results from measured value  $W_A$  plus base thickness  $F$ .  $\Rightarrow E_A$

Test value  $P_A$  is therefore space requirement  $E_A$  minus  $M_A$ .

01303

Value  $P_A$  should be between 3.68 and 5.08 mm.

**Testing specifications 1068 700 217**  
Version **B**

Select snap ring  $S_A$  with test value  $P_A$ .

**Calculation:**

$$E_A = W_A + F$$

$$P_A = E_A - M_A$$

Clearance  $L_A$  with 4 lining disks should be between 1.29 and 1.74 mm.

**Example (for 1.4.4):**

$$F = 1.48 \text{ mm (base thickness)}$$

$$W_A = 26.15 \text{ mm}$$

$$M_A = - 22.38 \text{ mm}$$

$$E_A = 26.15 + 1.18$$

$$= 27.33 \text{ mm}$$

$$P_A = 27.33 - 22.38$$

$$= 4.95 \text{ mm}$$

$$S_A = 3.6 \text{ mm}$$

$$L_A = 4.95 - 3.6$$

$$\Rightarrow L_A = 1.35 \text{ mm}$$



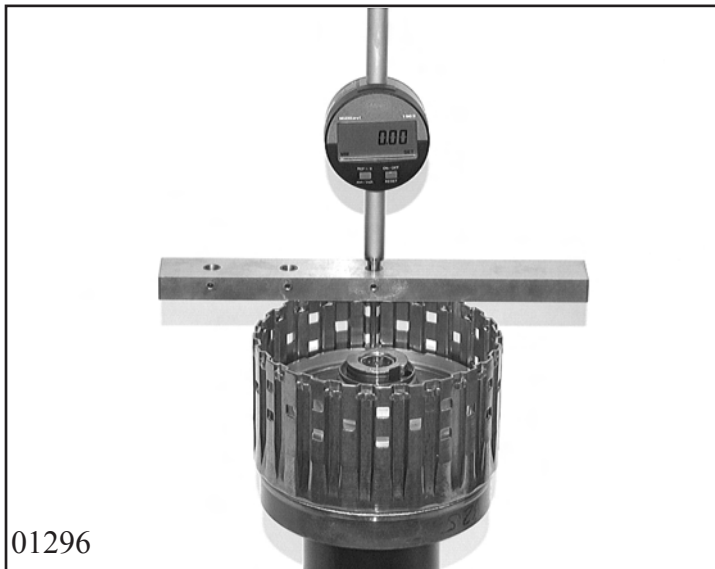

01296

#### 1.4.5 Clearance setting, clutch E (snap ring)

Determine space requirement  $E_E$  of clutch with measuring bar 5p01 000 330. For this purpose, place measuring bar 5p01 000 330 on cylinder edge of clutch E. Place measuring base on the highest point of the disk support area at the piston and set dial gauge to "0". Pull measuring sensor upwards, insert into snap ring groove and press against the upper edge of the groove.

Read off measured value at dial gauge  $\Rightarrow W_E$

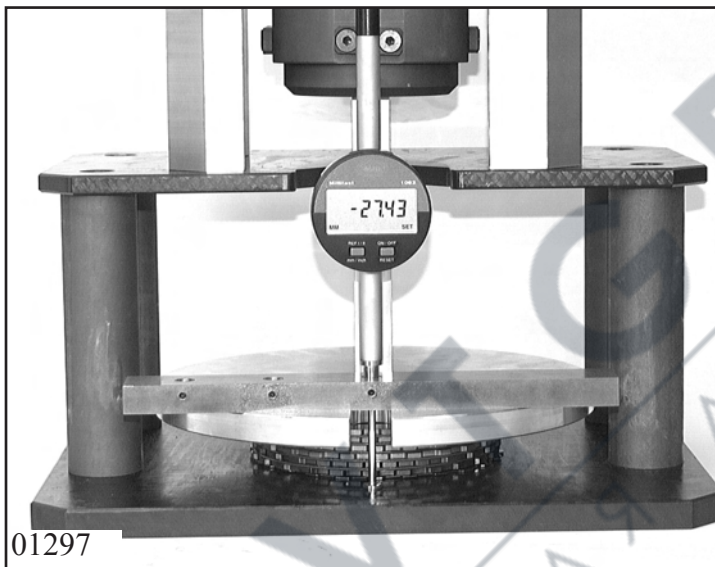

01297

Determine thickness  $M_E$  of clutch E clutch pack according to **Chapter 1.4.0 Measuring clutch pack.**

$\Rightarrow M_E$

Space requirement  $E_E$  results from measured value  $W_E$  plus base thickness  $F$ .  $\Rightarrow E_E$

Test value  $P_E$  is therefore space requirement  $E_E$  minus  $M_E$ .

Value  $P_E$  should be between 3.83 and 5.83 mm.

**Testing specification 1068 700 048**  
Version *B*.

Select snap ring  $S_E$  with test value  $P_E$ .

**Calculation:**

$$E_E = W_E + F$$

$$P_E = E_E - M_E$$

Clearance  $L_E$  with 5 lining disks should be between 1.84 and 2.37 mm.

**Example (for 1.4.5):**

$$F = 1.48 \text{ mm (base thickness)}$$

$$W_E = 30.27 \text{ mm}$$

$$M_E = 27.43 \text{ mm}$$

$$E_E = 30.27 + 1.48$$

$$= 31.75 \text{ mm}$$

$$P_E = 31.75 - 27.43$$

$$= 4.32 \text{ mm}$$

$$S_E = 2.4 \text{ mm}$$

$$L_E = 4.32 - 2.4$$

$$\Rightarrow L_E = 1.92 \text{ mm}$$





#### 1.4.6 Clearance - output (disk)

Screw measuring support into appropriate bore in transmission casing and place dial gauge on output shaft.

Press against flange and set dial gauge to "0".

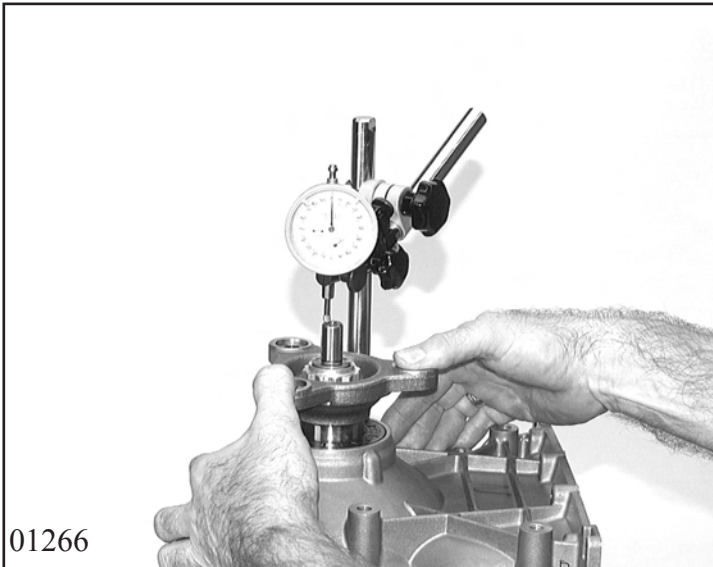

Pull on flange and read off value A.

Select a thinner or thicker disk if value A is outside tolerance C.



**Example: (for 1.4.6)**

**A = 0.15 mm**

**C = 0.15 to 0.35 mm**

◇ **disk o.k.**

### 1.4.7 Clearance - input (disk)

Secure oil supply in casing with 2 opposite fillister head screws 10.080.

(for tightening torque see Chapter 1.5)

#### Requirements:

Shim 10.090 (thickness = 2.6 mm, thinnest according to WTB) is in position

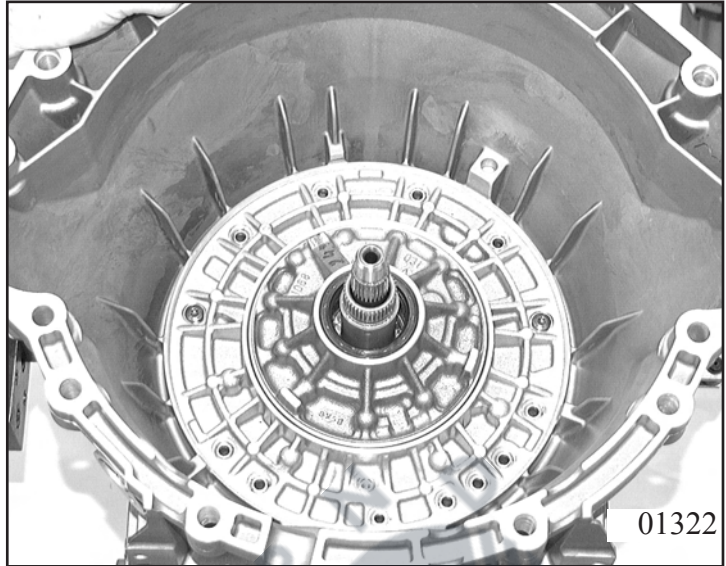

Push measuring device 5p01 002 379 over input shaft splines and clamp with locking screw approx. 2 mm above stator shaft.

Set dial gauge to 0.

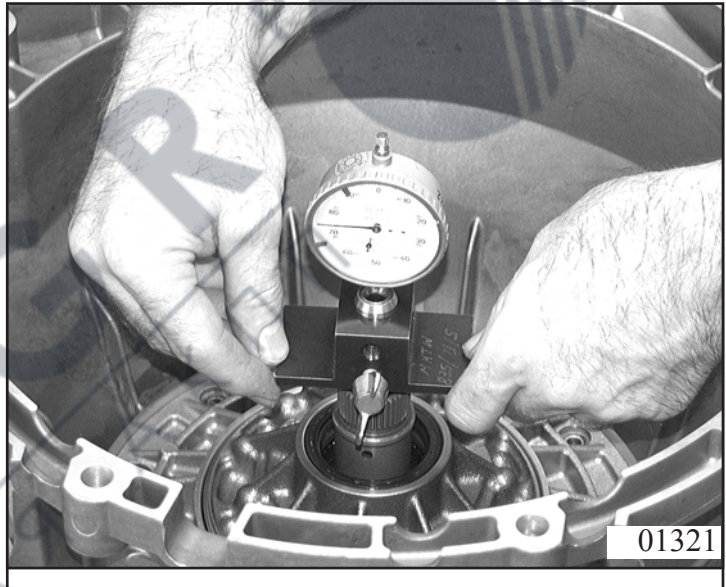

Determine axial clearance by pressing and pulling the handle (repeat measuring process several times).

Target axial clearance = 0.2 - 0.4 mm at a force of 200 N (dry according to **test specification 1068 700 051**)

If there is any deviation, insert a thicker or thinner disk 02.260 as appropriate. Check axial clearance again after this.

(M type only)

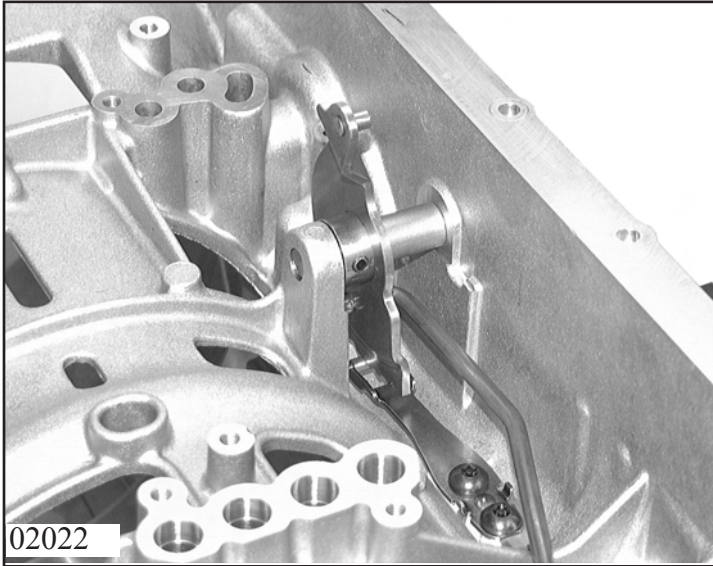

#### 1.4.8 Switch setting (detent spring)

Set locking disk with appropriate tool or manually to N position (neutral).

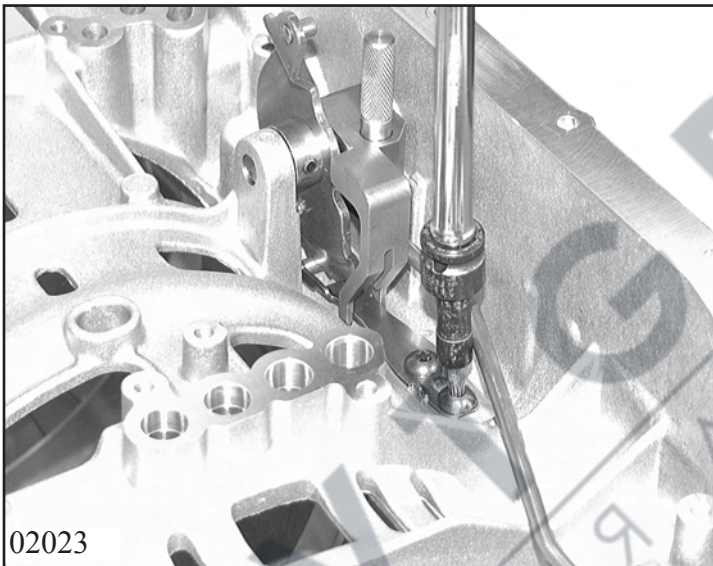

Align detent spring with centering device 5x46 002 292 and tighten detent spring in this position.  
Tighten output side screw first.

(for tightening torque see Chapter 1.5)

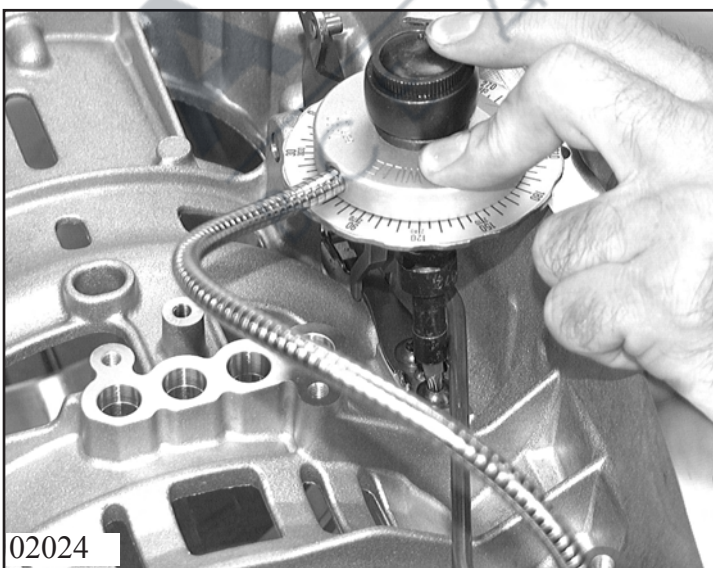

Tighten farther by the specified angle with special tool 5w04 000 583.  
Remove centering device.  
Shift the selector shaft through all positions and remove it again.

(for tightening torque see Chapter 1.5)



## 1.5 Tightening torques

No.	Designation	Part List-Item-No.	Wrench size No.	Page	Tightening torque [Nm]
1	Screw plug (transmission housing)	01.100	Hexagonal socket Size = 5 mm	3.1/2	12 Nm (±1.2 Nm)
2	Machine screw (detent spring M type)	06.090	TORX - TX 27 H	1.4/15 3.1/3	4 Nm ± 3% + (27° ± 2%)
3	Machine screw (guide plate)	24.120	TORX - TX 27	3.1/5	10 Nm (±1.0 Nm)
4	Screw plug M12x1.5 (torsion spring)	24.020	Hexagonal socket Size = 6 mm	3.1/4	23 Nm (±2.3 Nm)
5	Hex bolt (lever)	06.190	Hex Size = 13 mm	3.1/5	9.5 Nm (±1.0 Nm)
6	Machine screw (emergency release, E type)	06.210	TORX - TX 27	3.1/5	10 Nm (±1.0 Nm)
7	Collar nut (output-flange)	14.160	Socket wrench 5X46 002 456	3.2/3	60 Nm (±6.0 Nm)
8	Machine screw (stator shaft/intermediate plate)	10.040/150	TORX - TX 27	3.6/3	15 Nm (±1.5 Nm)
9	Machine screw (intermediate plate/centering plate)	10.040/180	TORX - TX 27	3.6/3	10 Nm (±1.0 Nm)
10	Machine screw (stator shaft/centering plate)	10.050	TORX - TX 27	3.6/3	15 Nm (±1.5 Nm)
11	Countersunk screw (intermediate plate/pump)	10.080 10.084	TORX - TX 27	1.4/14 3.6/4	10 Nm (±1.0 Nm)
12	Machine screw (Mechatronic)	27.450 27.500	TORX - TX 30	1.3/1 3.7/3	8 Nm (±0.8 Nm)
13	Machine screw (oil pan)	03.020	TORX - TX 27	1.3/1 3.7/4	10 Nm (±1.0 Nm)
14	Screw plug M16x1.5 (oil pan)	03.010/030	Hexagonal socket Size = 8 mm	3.7/4	9 Nm (-1.0 Nm)
15	Hex bolt M8x45 (converter retaining bracket)	97.020	Size = 13 mm	3.7/5	15 Nm (±1.5 Nm)

No.	Designation	Part List- Item-No.	Wrench size No.	Page	Tightening torque [Nm]
16	Hex bolt M10x16 (converter retaining bracket)	97.030	Size = 17 mm	3.7/5	15 Nm (±1.5 Nm)



## **1.6 Transmission test (test bench)**

The following points must be checked:

### **Correct oil level**

Proper oil level; observe the vehicle manufacturer's specifications, as well as the list of lubricants TE-ML 11 (Serviceline) and SDM.

### **Oil level too low**

This can result in:

Engine over-revving or no power flow in curves or when starting from a stop

Valve chatter due to air pockets in the oil

General malfunctions

Among other things, burned clutches can be the result.

### **Oil level too high**

Danger of loss due to splashing, formation of foam, strong increases in temperature at high road speeds. Loss of oil via breather; among other things, burned clutches and shifting problems can result.

### **Proper engine settings**

Correct idle speed; follow specifications from vehicle manufacturer.

### **Power flow, forward and reverse**

Correct adjustment of selector linkage or control cable; observe the vehicle manufacturer's specifications.



### **Cooler-bypass or cooler connection on the test bench**



Do not overheat transmission, maximum 120° C.



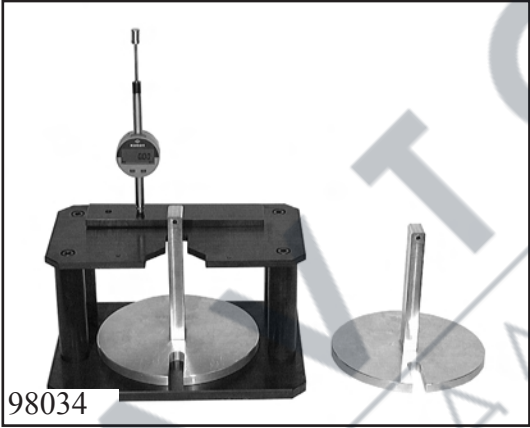



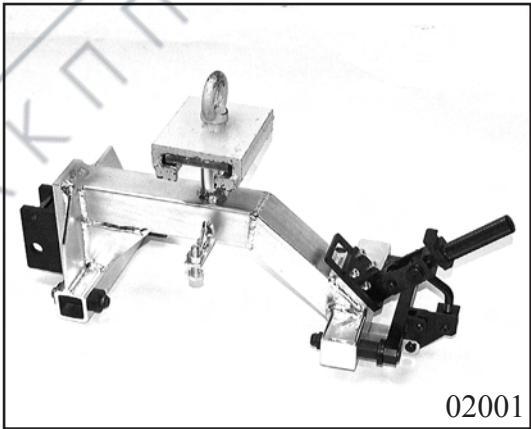



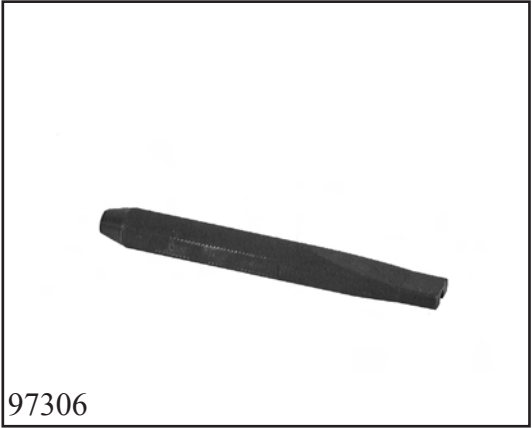

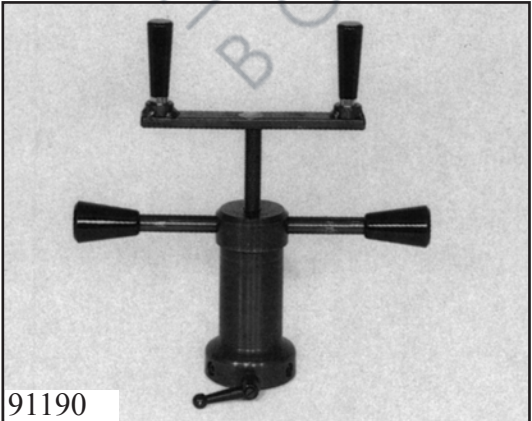
## 1.7 Special tools

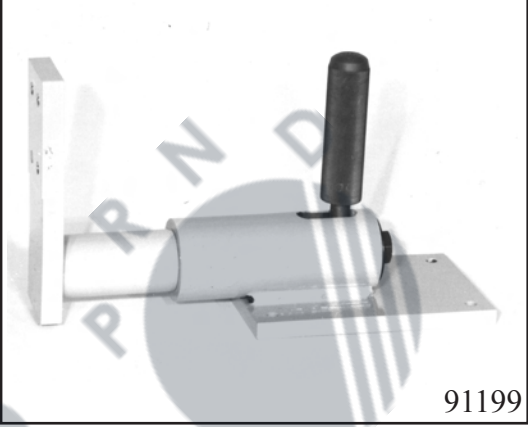

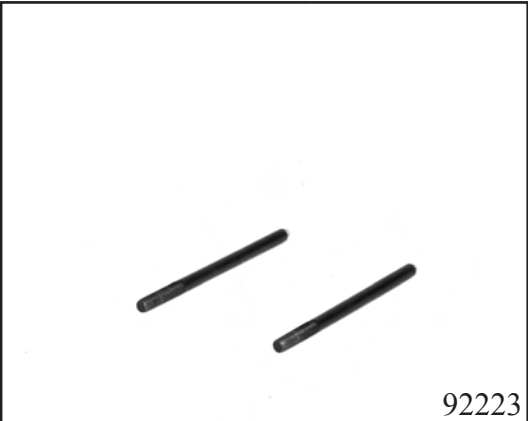
OBJECT	Order-No. / Application	Remarks
<p style="text-align: center;">1</p>  <p>98008</p>	<p>5p01 000 329 Force gauge</p>	<p>identical</p> <p>4 HP 20 ---- 6 HP 32/A/X</p>
<p style="text-align: center;">2</p>  <p>98034</p>	<p>5p01 000 330 Clutch play measuring device</p> <p>(Measuring plate: - short neck &gt; 20 mm - long neck &lt; 20 mm clutch disk thickness)</p>	<p>identical</p> <p>4 HP 20 ---- 6 HP 32/A/X</p>
<p style="text-align: center;">3</p> 	<p>5p01 001 458 Pre-tension adjusting device</p>	<p>identical</p> <p>4 HP 18 Q ---- 6 HP 32/A/X</p>

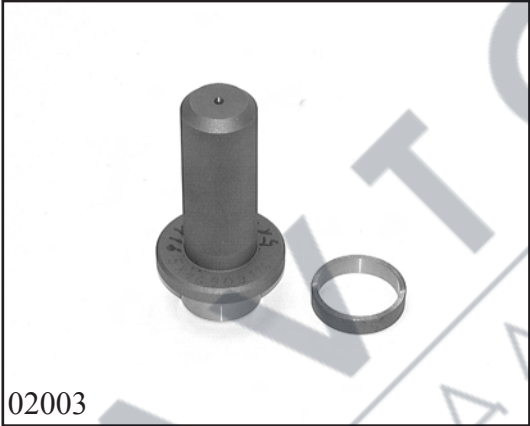

Remarks	Order-No. / Application	OBJECT
identical 4 HP 20 ---- 6 HP 32/A/X	5p01 002 379 Input shaft axial play measuring device	4 
identical 6 HP 26	5t66 000 094 Transmission retaining bracket	5 
identical 5 HP 18 ..... 6 HP 32/A/X	5x46 001 502 Assembly bracket, brake D	6 

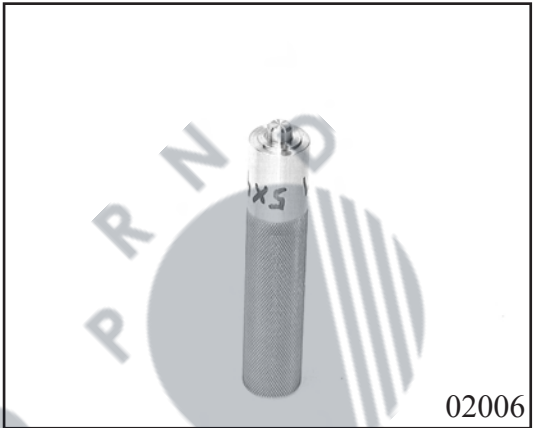

OBJECT	Order-No. / Application	Remarks
<p style="text-align: center;">7</p>  <p>97306</p>	<p>5x46 000 291 Locking sleeve driving-in mandrel</p>	<p>identical</p> <p>4 HP 18 Q ---- 6 HP 32/A/X</p>
<p style="text-align: center;">8</p>  <p>98135</p>	<p>5x46 000 306 Pump torque checking sleeve</p>	<p>identical</p> <p>4 HP 18 Q ---- 6 HP 32/A/X</p>
<p style="text-align: center;">9</p>  <p>91190</p>	<p>5x46 000 563 Disassembly/assembly fixture for complete oil supply unit</p>	<p>identical</p> <p>5 HP 18 5 HP 24 A 5 HP 30 6 HP 26 A61 6 HP 26</p>

Remarks	Order-No. / Application	OBJECT
identical 4 HP 20 ---- 6 HP 32/A/X	5x46 000 763 Work-bench holder	10  91199
identical 5 HP 24 ---- 6 HP 32/A/X	5x46 000 917 Mount	11  92214
identical 5 HP 19 ---- 6 HP 32/A/X	5x46 001 007 2 locating pins	12  92223

OBJECT	Order-No. / Application	Remarks
<p style="text-align: center;">13</p>  <p>02002</p>	<p>5x46 002 456 Nut wrench</p>	<p>identical</p> <p>6 HP 26 6 HP 19 6 HP 32 6 HP 21</p>
<p style="text-align: center;">14</p>  <p>02003</p>	<p>5x46 002 558 Driving-in mandrel for needle roller bearing and pump shaft sealing ring</p>	<p>identical</p> <p>6 HP 19/A/X ---- 6 HP 32/A/X</p>
<p style="text-align: center;">15</p>  <p>02004</p>	<p>5x46 004 373 Driving-in mandrel for shaft sealing ring + needle roller bearing</p>	<p>identical</p> <p>6 HP 26 6 HP 32</p>

Remarks	Order-No. / Application	OBJECT
identical 6 HP 19/A/X ---- 6 HP 32	5x46 002 561 Driving-in mandrel for shaft sealing ring WDR	16 
identical 5 HP 18 ---- 6 HP 32/A/X	5x46 001 500 Assembly bracket for clutch A, B, D, E	17 
identical 5 HP 18 ---- 6 HP 32/A/X	5x46 001 500 Assembly bracket for brake C	18 

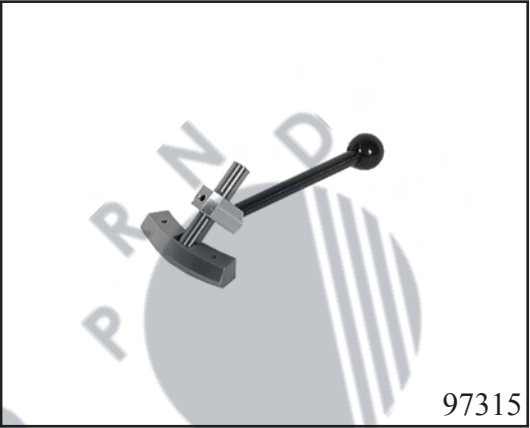
OBJECT	Order-No. / Application	Remarks
<p style="text-align: center;">19</p>  <p>02011</p>	<p>5x46 002 569 Pull-out handle</p>	<p>identical</p> <p>6 HP 19/A/X ---- 6 HP 32/A/X</p>
<p style="text-align: center;">20</p>  <p>02012</p>	<p>5x46 002 571 Assembly aid, clutch E snap ring</p>	<p>identical</p> <p>6 HP 19/A/X ---- 6 HP 32/A/X</p>
<p style="text-align: center;">21</p>  <p>76076</p>	<p>5x56 000 090 2 converter pull-out handles</p>	<p>identical</p> <p>4 HP 18 Q ---- 6 HP 32/A/X</p>

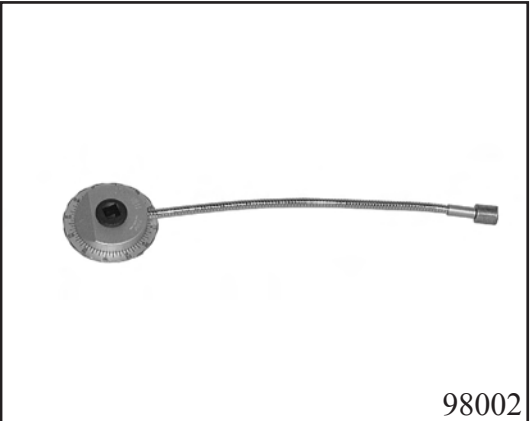
Remarks	Order-No. / Application	OBJECT
identical 5 HP 24 ---- 6 HP 32A/X	5x46 001 930 Driving tool for snap ring in the groove of the housing	22  97315
identical 6 HP 19/A/X ---- 6 HP 32/A/X	5x46 002 849 Mandrel helium-shaft sealing ring  5x46 012 696 Press-in aid helium-shaft sealing ring BMW  5x46 012 798 Press-in aid helium-shaft sealing ring Jaguar	23, 24, 25  02036
identical 6 HP 19/A/X ---- 6 HP 32/A/X	( <i>M type only</i> ) 5w04 000 583 Torsional measuring device, detent spring assembly	26  98002

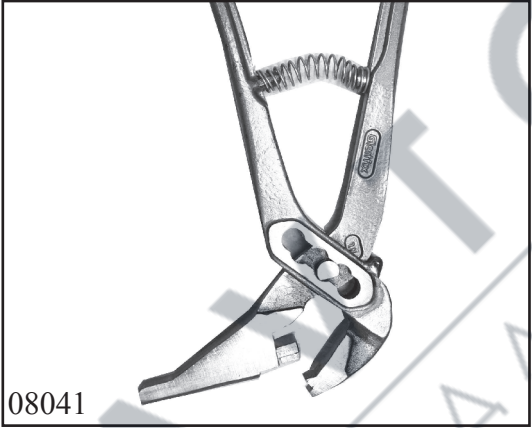

OBJECT	Order-No. / Application	Remarks
<p style="text-align: center;">27</p>  <p>02026</p>	<p>5x46 002 292 Centering device, detent spring</p>	<p>identical 6 HP 19/A/X ---- 6 HP 32/A/X</p>
<p style="text-align: center;">28</p>  <p>08041</p>	<p>5x46 003 981 snap ring pliers</p>	<p>identical 6 HP 19/A/X ---- 6 HP 32/A/X</p>



# 1.8 Oilflow chart (Position N) (E - type)

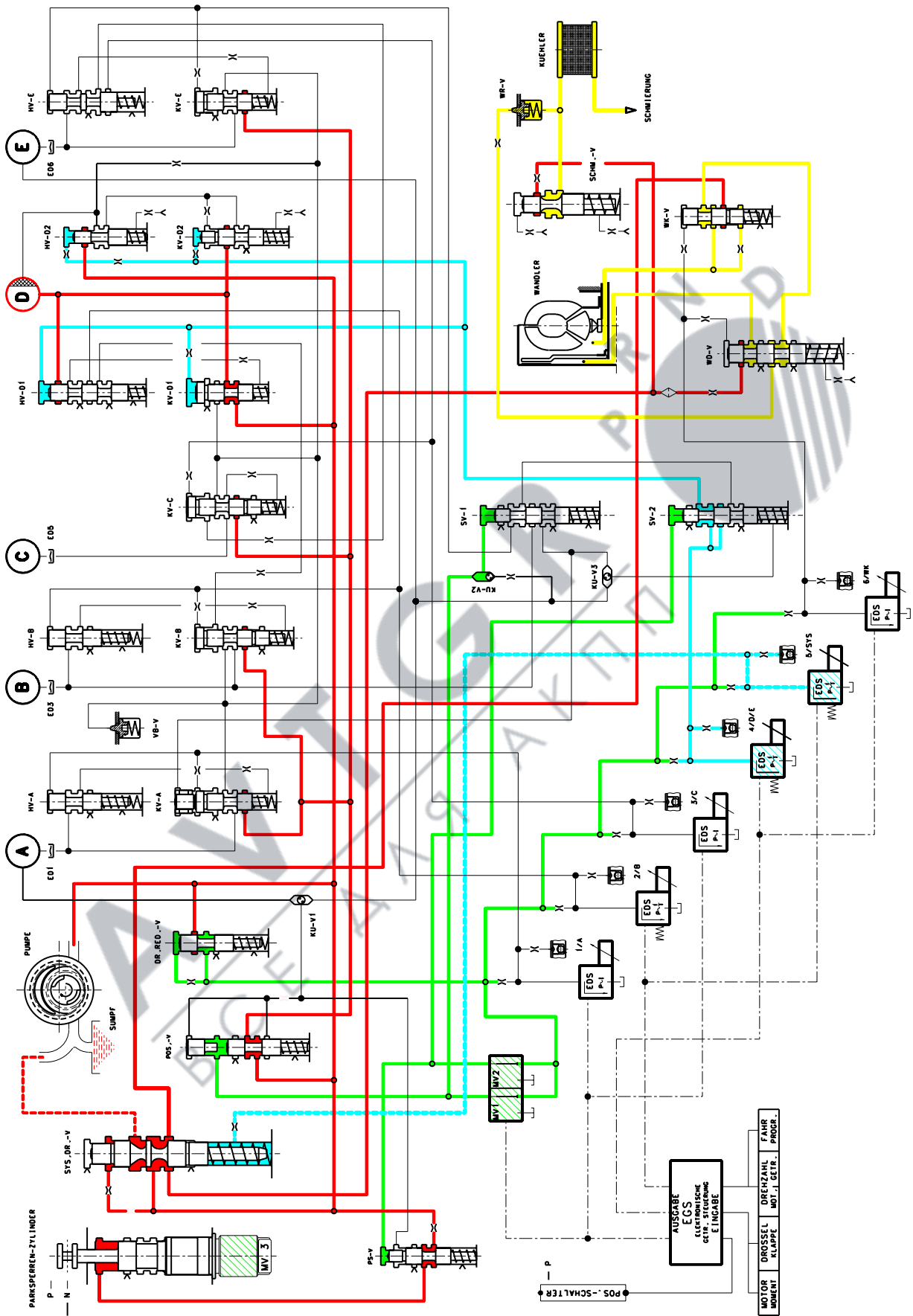

(M - type)

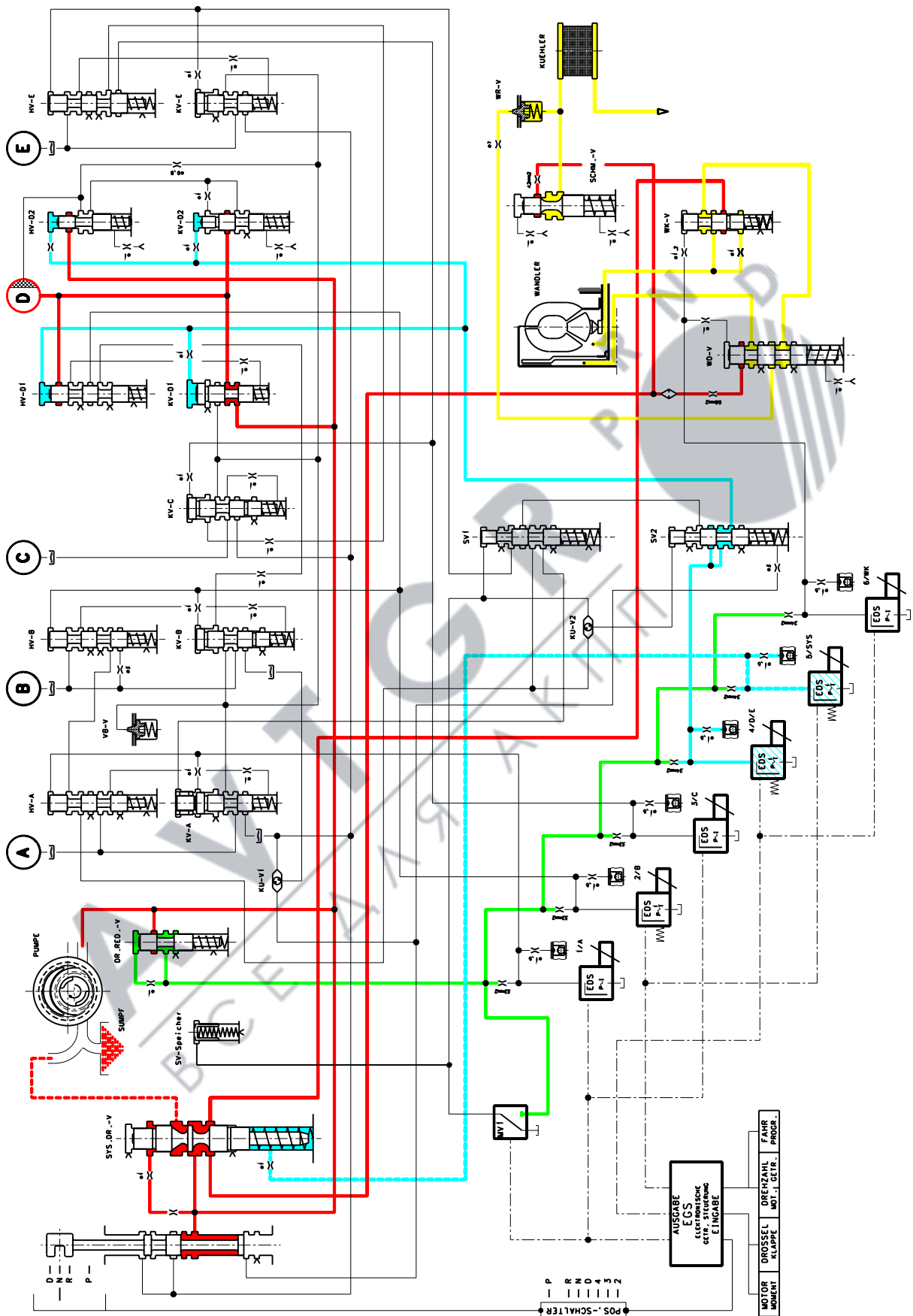

## 2. Disassembly

### 2.1 Transmission disassembly according to component groups

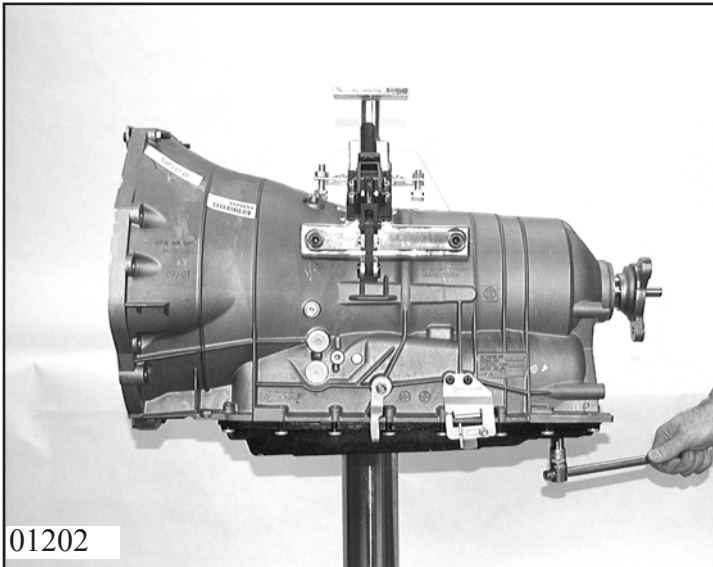

Clamp transmission into support bracket 5t66 000 094 and fasten to assembly trolley, if necessary in workbench holding device 5x46 000 763.

Screw out oil drain plug /oil filler cap and drain oil.

#### Wrench sizes

Oil drain plug = 10 mm Hexagonal socket

Oil filler plug = 8 mm Hexagonal socket

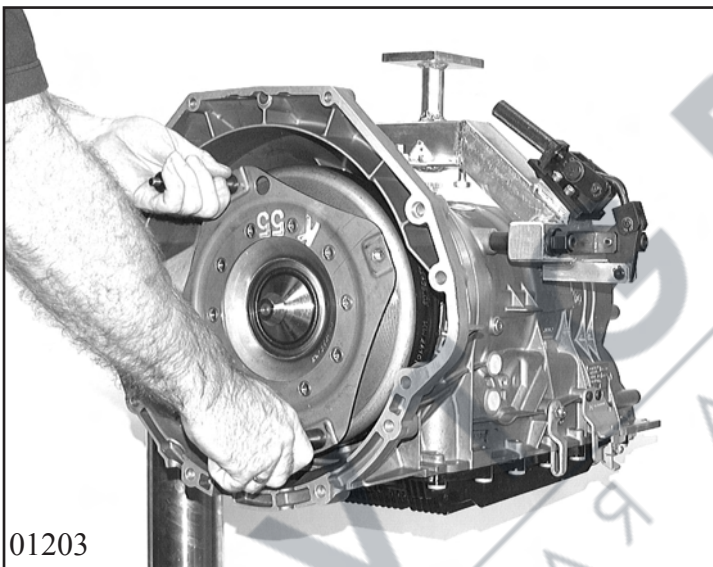

Remove converter bracket and take out converter using the two converter pull-out handles 5x56 000 090.

(Wrench size = 13 mm)

(Wrench size = 17 mm)

#### **Warning!**

Oil may be spilled.

Do not damage converter bearings and shaft sealing ring of the pump.

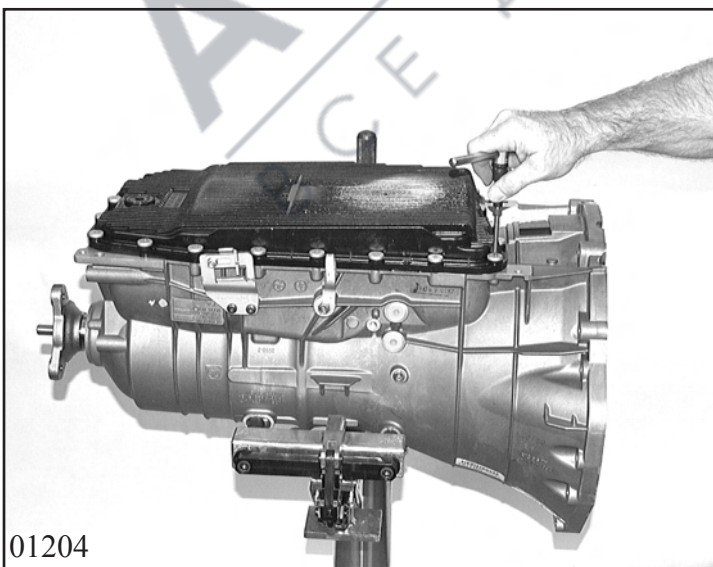

Turn transmission by 180°.

Unscrew 21 machine screws holding the oil pan, remove it and pull off the O-ring seal and gasket.

(Wrench size = Torx - TX 40)

Pull protective transport cap off socket for wiring harness and release retaining clamp.  
Pull socket out of casing by hand.

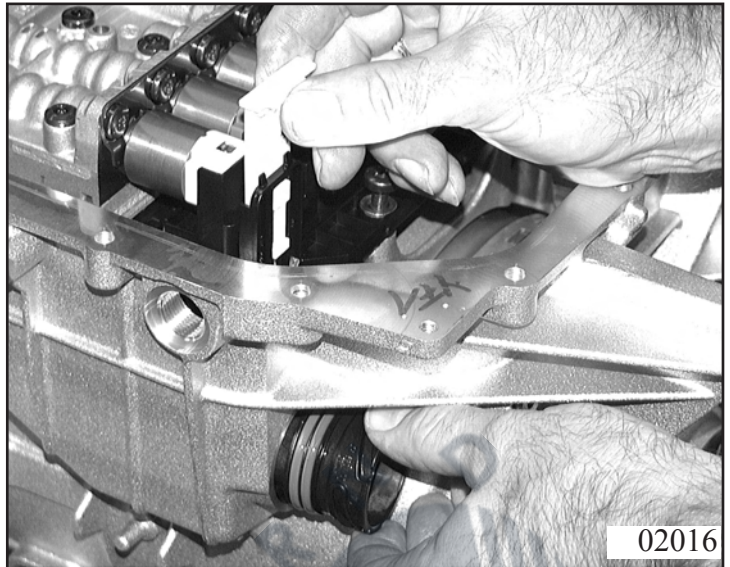

Unscrew screws with **large head** (M6) and lift off complete Mechatronics.

(Wrench size = Torx - TX 40)

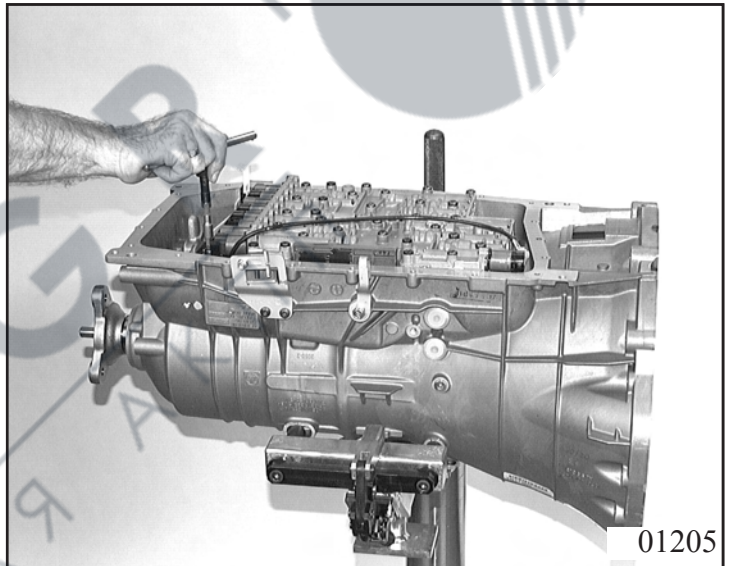

Pull 4 sealing sleeves out of transmission casing with handle 5x46 002 569.

Remove adaptor from transmission casing.

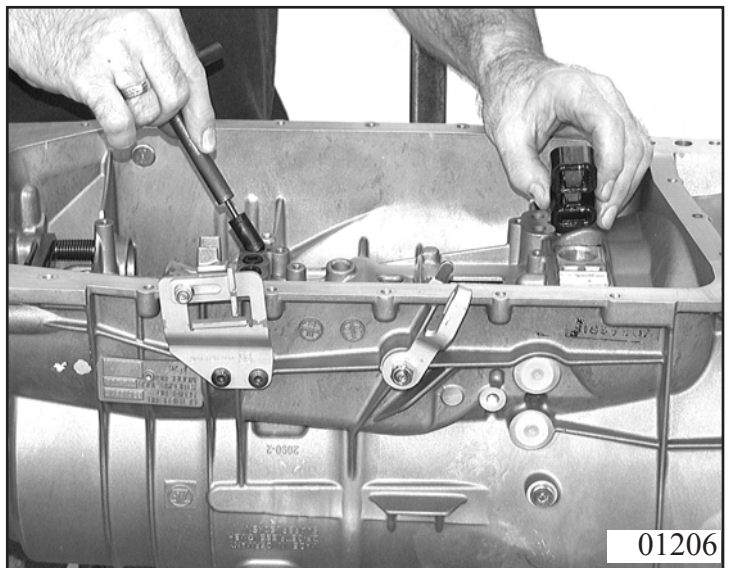



Turn transmission by 90°. Completely remove oil supply unit. To do this, loosen 14 Torx screws and remove with Uisit rings.

(Wrench size = Torx - TX 27)

01207



Press out the oil supply unit with jack 5x46 000 563 and lift off.

01208

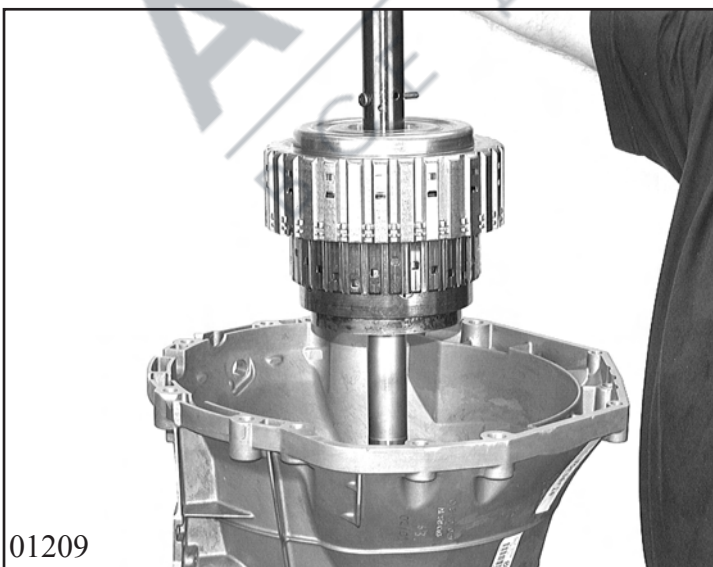

Take out the shim washer. Remove turret (input with clutches A and E).

Take out the complete unit by hand. Insert turret into fixture 5x46 000 917 and remove the fixture.

01209

Remove axial needle roller bearing cage from hub of cylinder B.

**Warning!**

The second angled thrust washer is located in the hub of internal disk carrier B and could be loosened during cleaning.

**Risk of loss!**

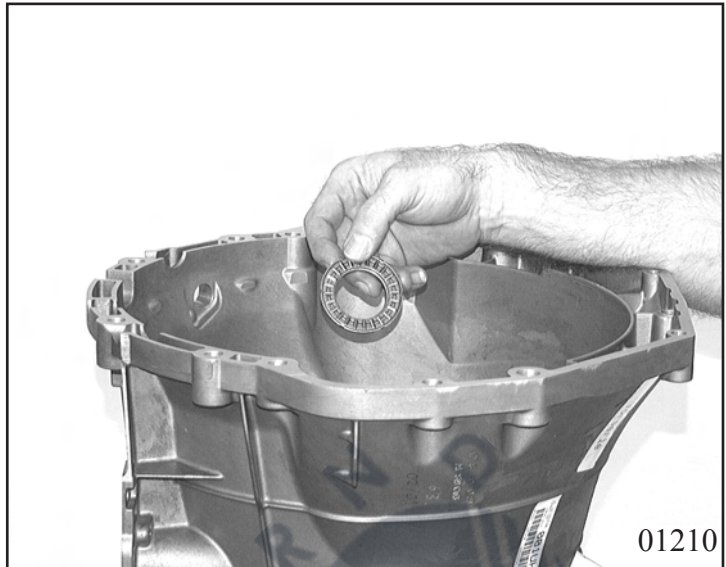

Remove clutch B by hand.

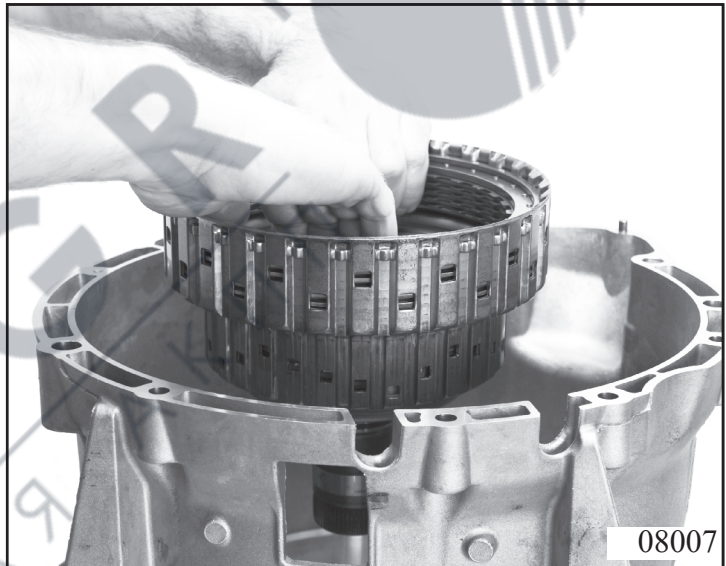

Turn transmission by 90° and loosen the 12-sided nut with wrench 5x46 002 456. Pull off the output flange.

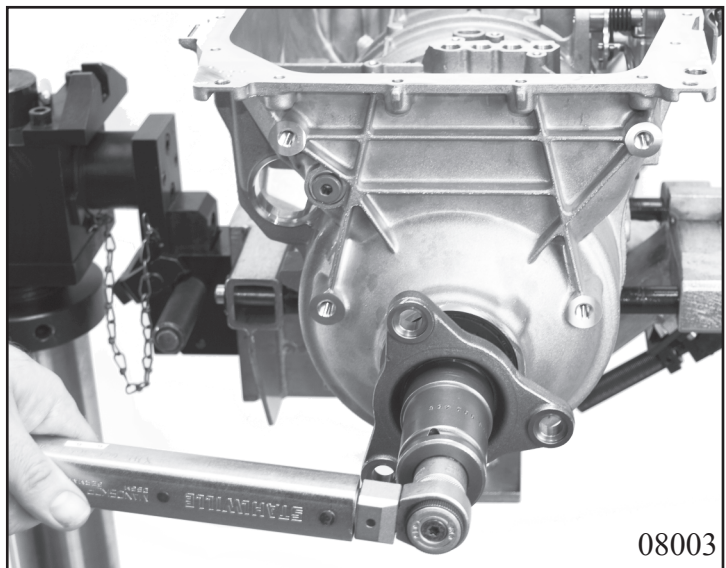



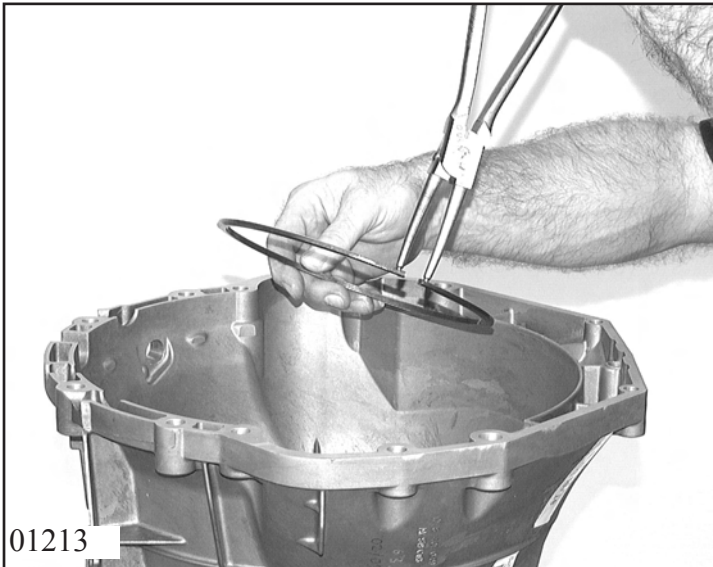

Turn transmission by 90° and lever snap ring out of casing with a screwdriver or take it out with snap ring pliers. Lift off clutch C.

01213

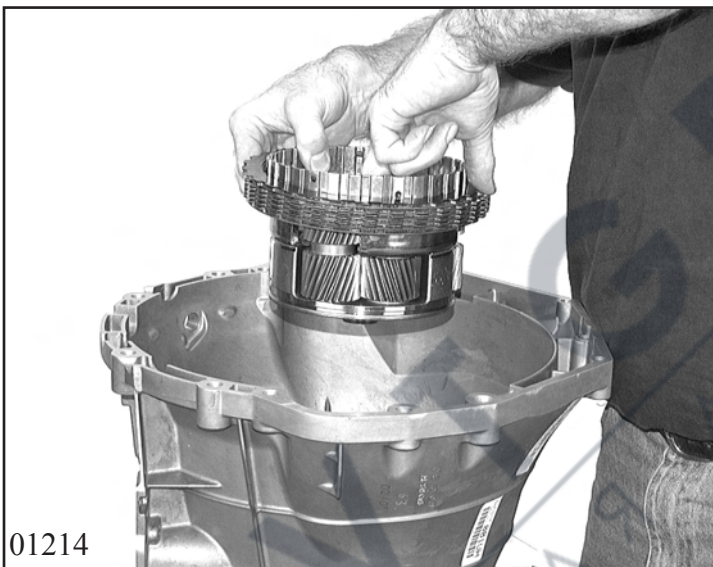

Take out the angle plate and sun gear. Remove planet carrier with complete clutch pack D. Remove final disk from transmission casing. Remove complete clutch pack D from planet carrier.

01214

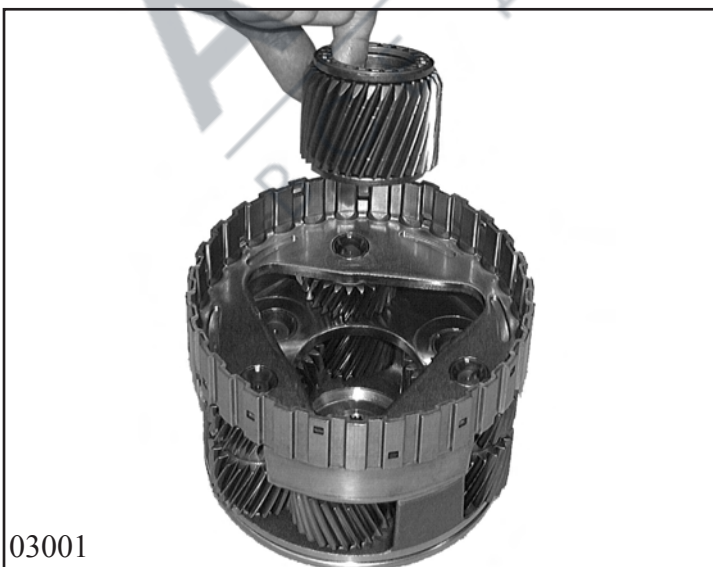

Take off sun wheel 2 from planet carrier. Clip off both axial needle bearing from sun wheel. Remove bearing disk from planet carrier. Clip off axial needle bearing on backside of planet carrier.

03001

Lift thrust washer off planet carrier hub.  
Take out ring gear with output shaft.  
Remove output axial clearance adjusting disk.  
Remove reversing disk.

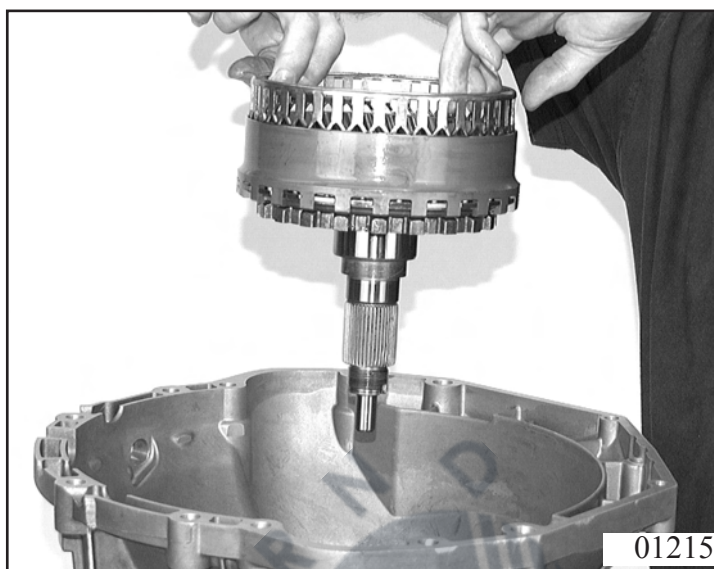

AVTGR  
ВСЕ ДЛЯ АКПП

## Dismantling

### 2.2 Turret (with clutches A and E)

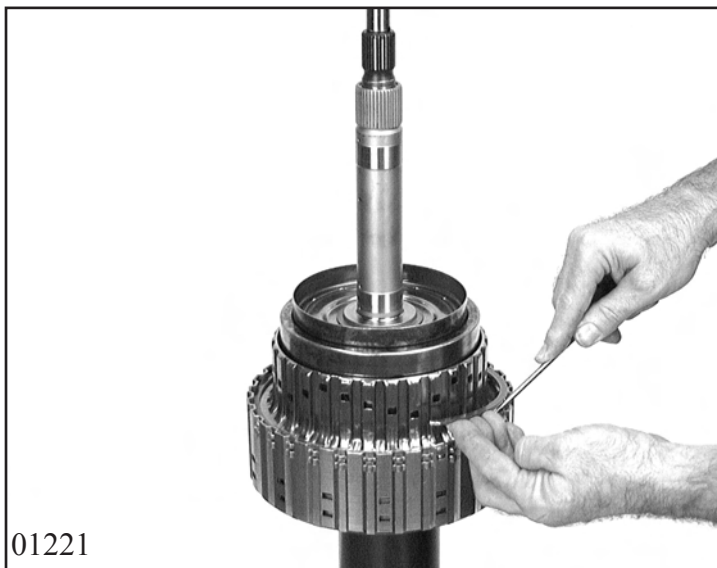

Put turret with input shaft in mount 5x46 000 917.

Unclip the angled disk.

Take out the snap ring and remove internal disk carrier B.

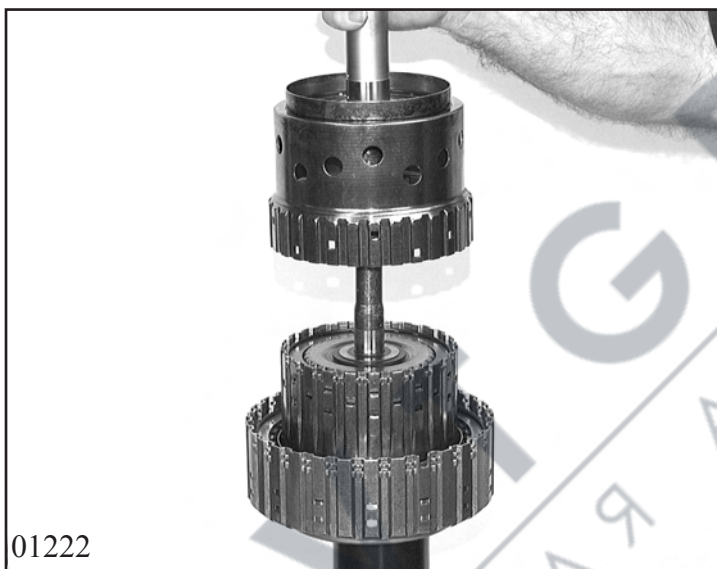

Take out disk carrier A and lever axial needle roller bearing out of intermediate shaft with a long scribe.

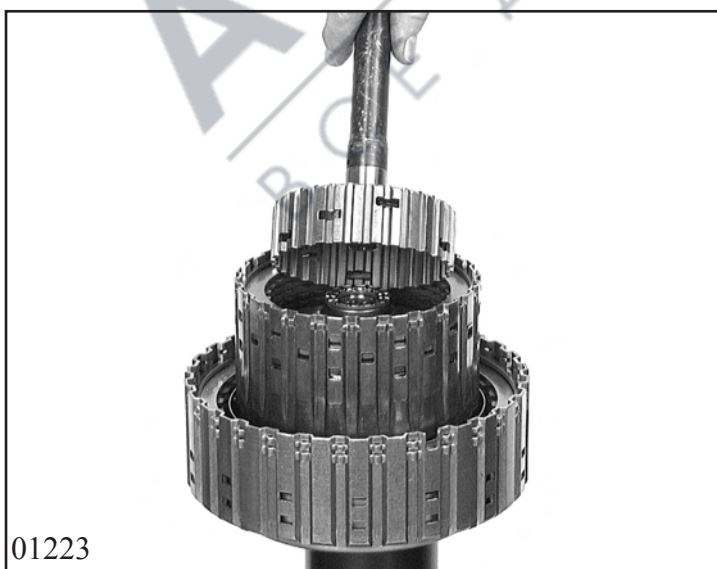

Lift off intermediate shaft with internal disk carrier E. Lever out axial needle roller bearing.

Then turn cluster by 180° and insert it into the fixture again.

Pull clutch A off clutch E / input shaft.



Rebound the snap ring of clutch A and pull out the complete disk set.

Prise out carefully with a screwdriver at several points the oil tray on the planet carrier and detach it.

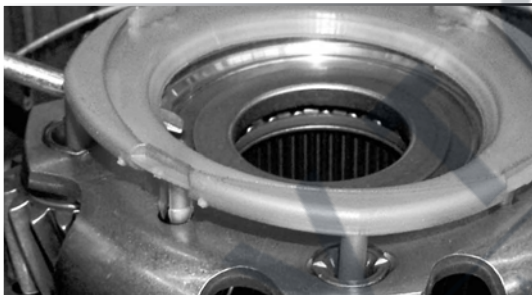

Prise out snap ring with a small screwdriver from the planet carrier at several points alongside the planet gear. At the same time raise slightly the planetary gear set.

Detach the planet carrier from cylinder A.

Detach snap ring and sun wheel from planet carrier and prise out the axial needle bearing.

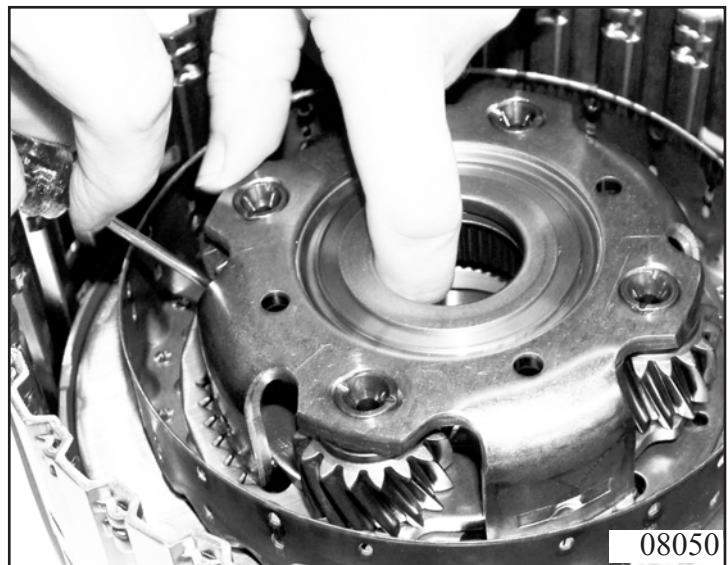



01227

Press down cup spring in the mandrel press with assembly bracket 5x46 001 500 and remove snap ring with suitable pliers. Take out baffle plate and cup spring.  
Pull the prof. seal ring off the baffle plate.

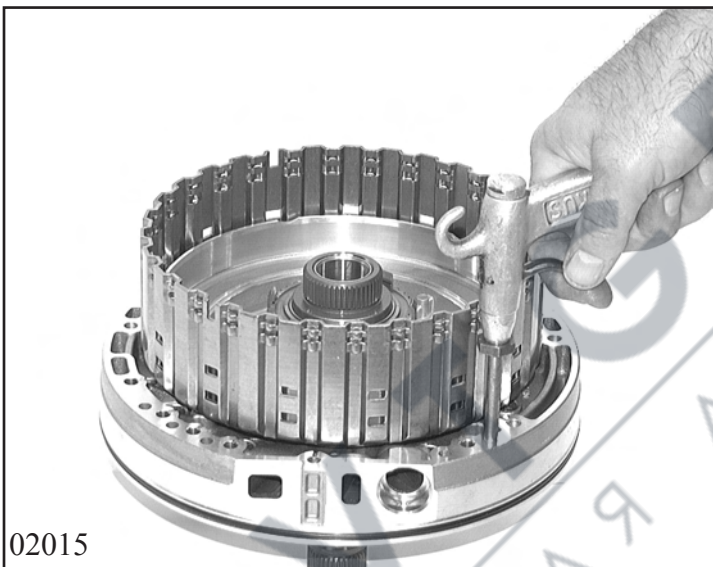

02015

Place cylinder A on top of the oil supply and press out piston with compressed air. Pull 1 prof. seal ring and 1 O-ring seal off piston A.  
Remove cylinder A from oil supply

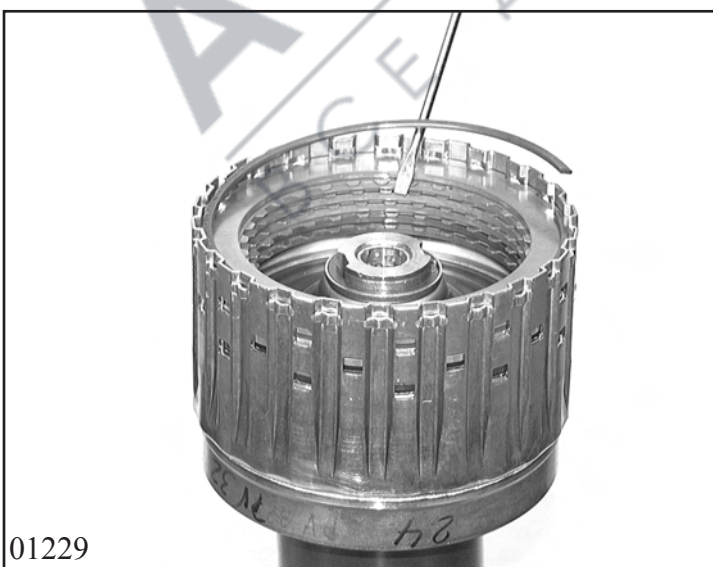

01229

Pull out clutch E snap ring and withdraw complete clutch pack of clutch E.

Press down baffle plate with assembly strap 5x46 001 502 and remove snap ring with suitable pliers. Take out baffle plate and cup spring and pull O-ring seal off baffle plate.

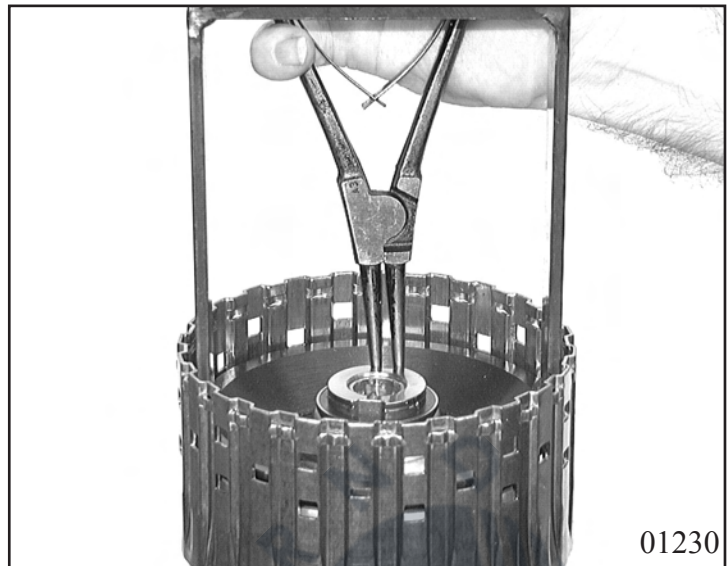

Cover one of the two oil guide bores and press out piston E with compressed air. Pull off the two O-ring seals.

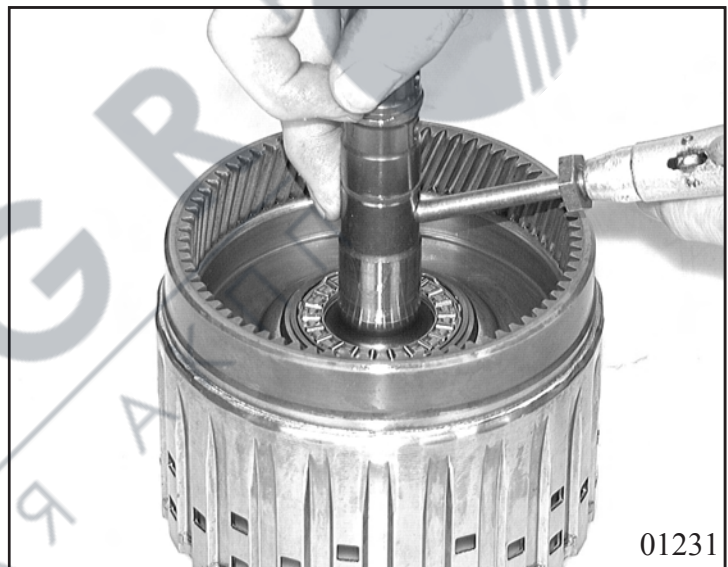

Pull the 3 rectangular-section rings off the drive shaft.



**Note!**  
Unclip needle roller bearing if defective.

### 2.3 Oil supply

Place complete oil supply on a suitable underlay support. Slide the 2 rectangular-section rings off the stator shaft.



01216

Loosen 11 machine screws (countersunk head - outer ring of stator shaft); do not take out two machine screws on opposite sides fully. Drive out the pump by striking these screws carefully with a plastic-faced hammer.

(Wrench size = Torx - TX 30)

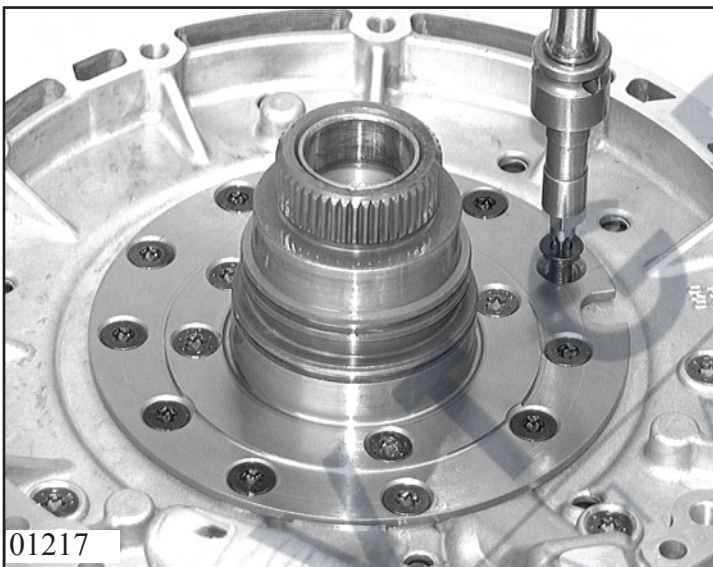

01217

Pull off O-ring seal. The pump can be dismantled by taking out the impeller and ring gear.

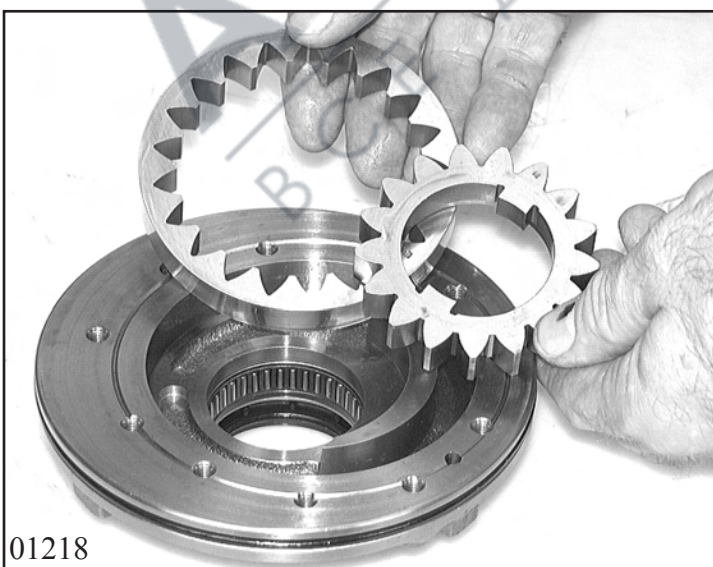

01218

Lever out shaft sealing ring with a suitable screwdriver. Pull out snap ring.  
If necessary, press out sealing ring with needle roller bearing from the side of the pump wheel using the mandrel press with a suitable tool.  
For that turn the pump housing.  
Thrust pin diameter approx. (42) mm.

**Remark**

Needle roller bearing will be destroyed and must be renewed

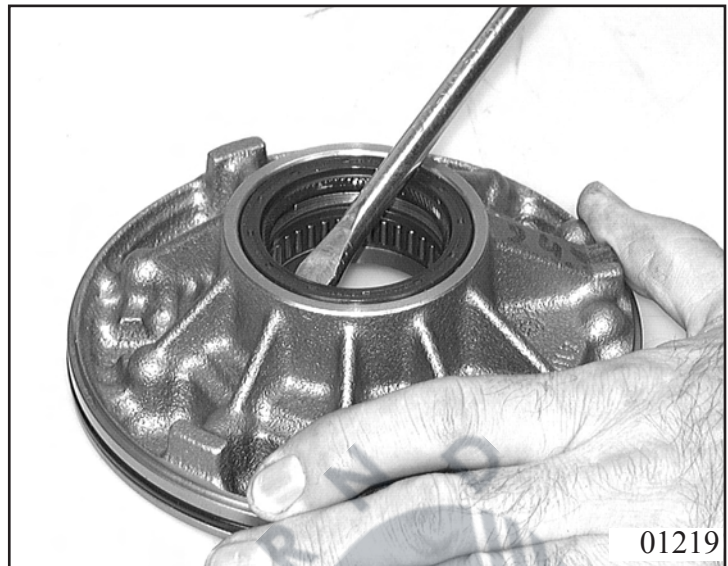

Loosen the six remaining countersunk screws, heat the casing around the stator shaft to approx. 70° C and drive the stator shaft out of the intermediate plate with a plastic-faced hammer.  
Remove the 4 countersunk screws out of the intermediate plate and remove it from the cover.

(Wrench size = Torx - TX 30)

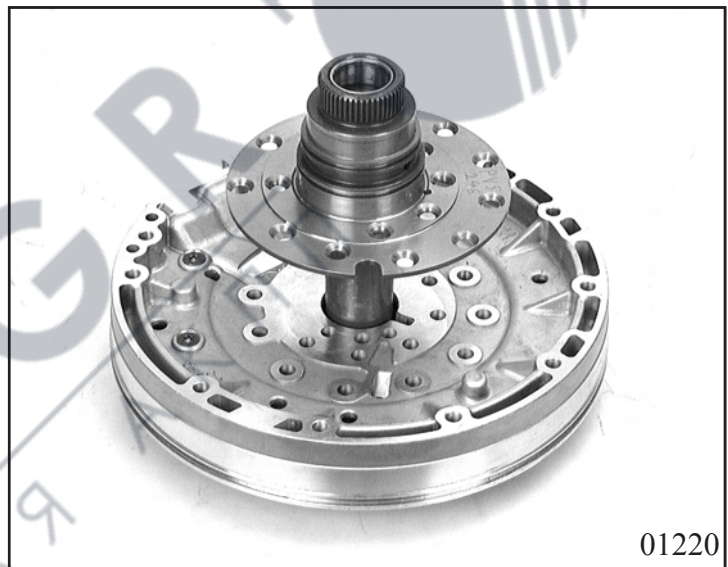



## 2.4 Clutch B

Unclip needle roller bearing from clutch B carrier.



Turn cylinder by 180°, take out clutch B snap ring and take out the complete clutch pack.

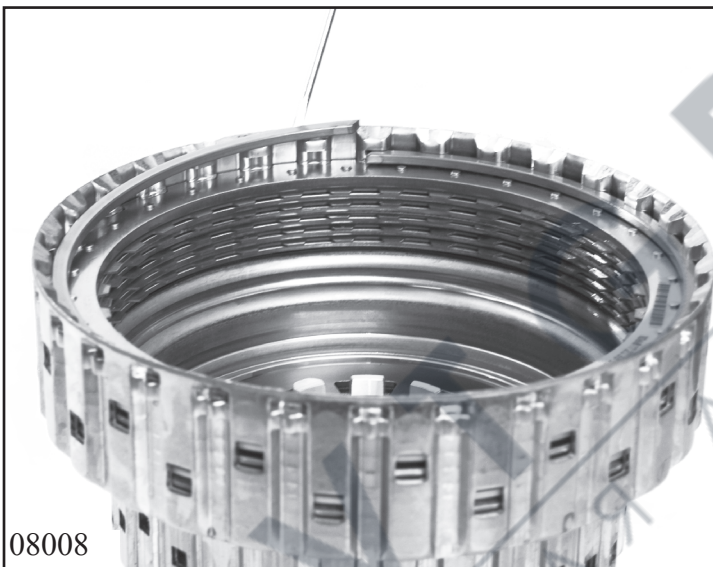

Press down cup spring B in the mandrel press with assembly bracket 5x46 001 502 and take out the snap ring. Remove washer and cup spring.

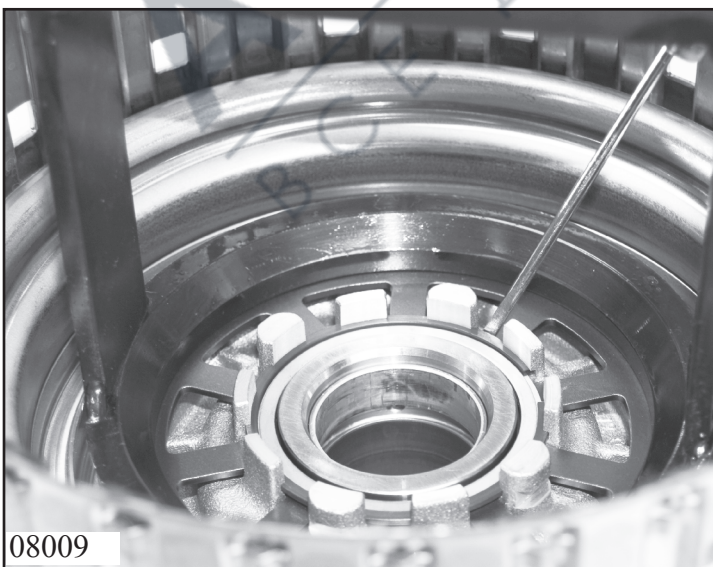

Lever out the snap ring.  
Take out baffle plate.  
Turn around cylinder.

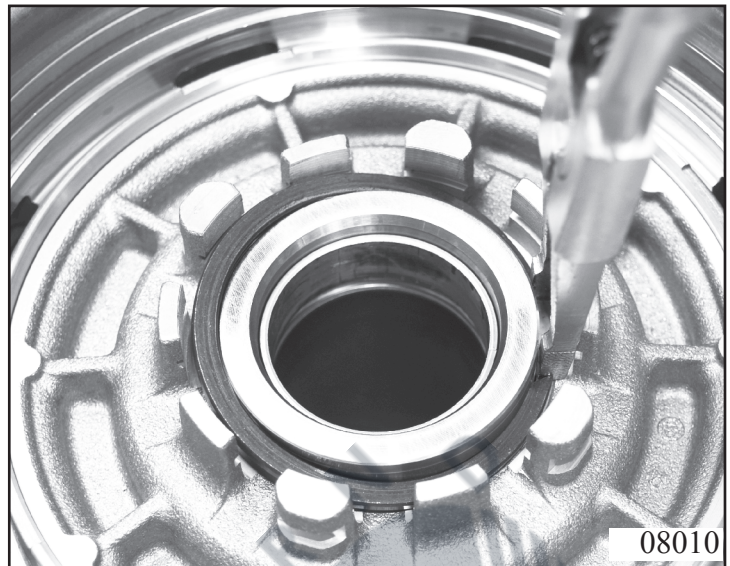

Cover one of the two oil guide bores and  
press out the piston, using pressurized  
air.  
Pull 1 O-ring seal from baffle plate and 2  
O-ring seals from piston.  
Pull 2 cylindrical rings from shaft.

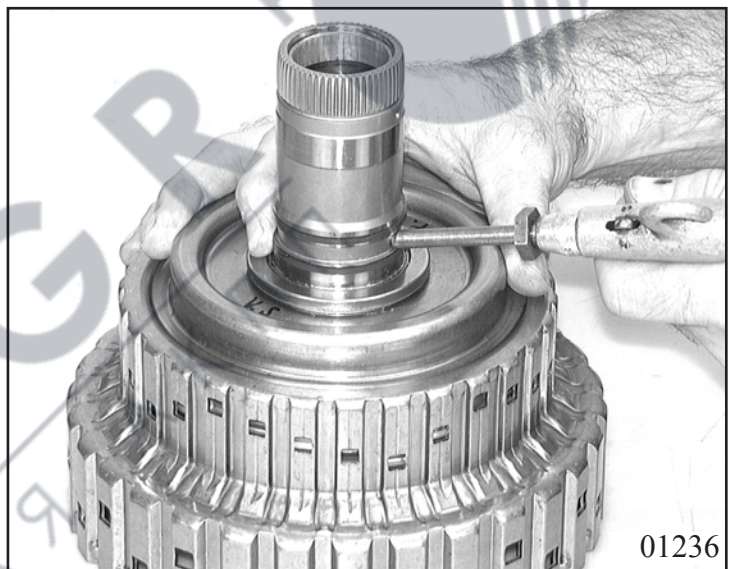

## 2.5 Brakes C and D

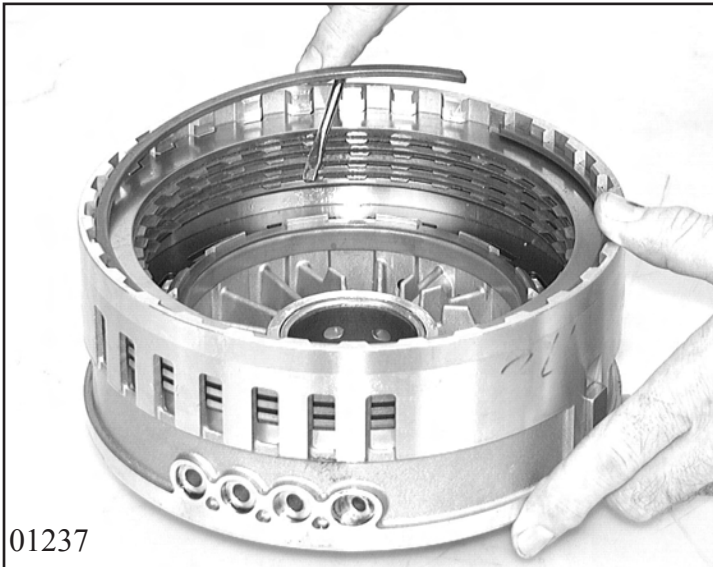

Lever out snap ring of brake C and remove complete clutch pack. Remove angle washer and axial needle bearing from underside (B-side)

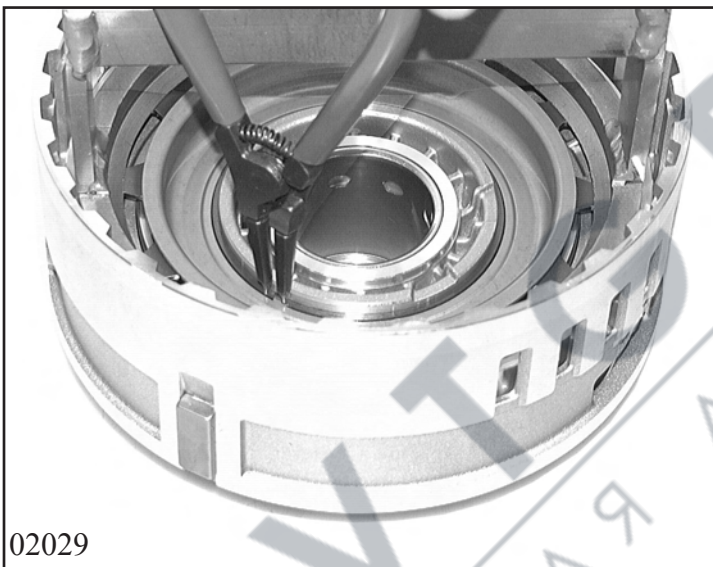

Press down cup spring C in the mandrel press with assembly bracket 5x46 001 501, lever out the snap ring and remove the cup spring.

Via the oil guide bores press out carefully by compressed air the piston C. Pull both lip-type sealing rings

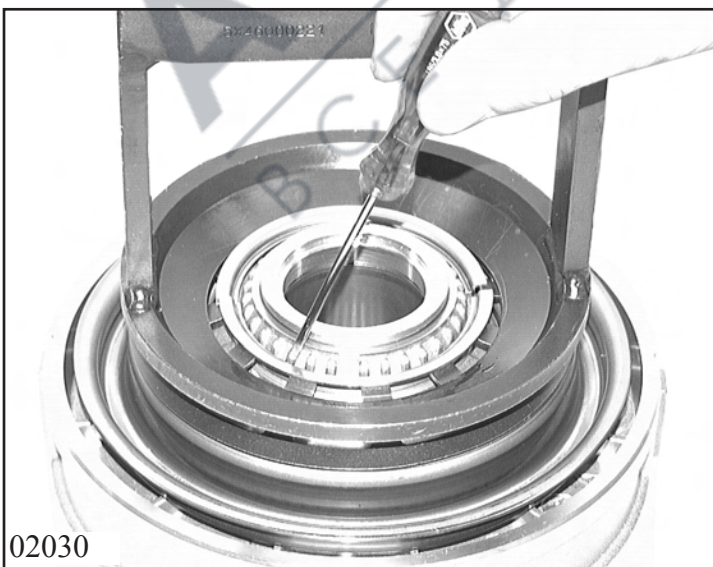

Turn the cylinder around and press down cup spring D in the mandrel press with assembly bracket 5x46 001 500; take out split retaining ring.

Take out baffle plate with cup spring and split retaining ring.  
Pull sealing ring off baffle plate.



Carefully press out piston D with a compressed air supply at the oil guide bore.

Pull 1 lip-type sealing ring and 1 O-ring seals from cylinder D and 1 O-ring seal off the piston.



Clip split retaining ring out of baffle-plate, take out cup spring from baffle plate.

## 2.6 Output shaft with parking lock

Separate the output shaft from the ring gear by levering out the snap ring.

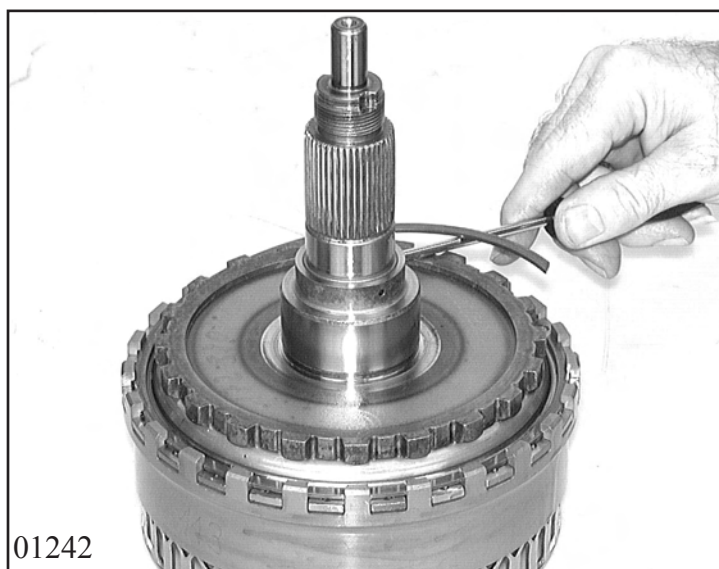



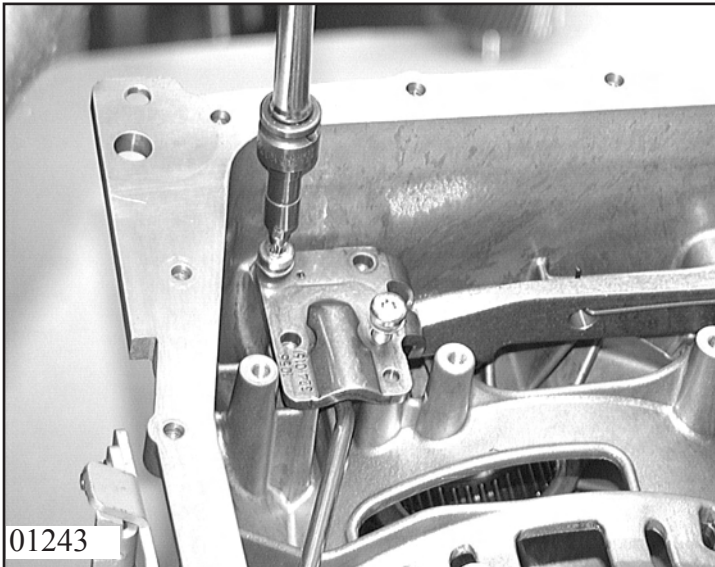

## 2.7 Transmission casing with shift-control and parking lock

Loosen locknut and pull off lever.  
Loosen the 4 machine screws and take out the guide plate.

(Wrench size = Torx - TX 27)

*(for E Version)*

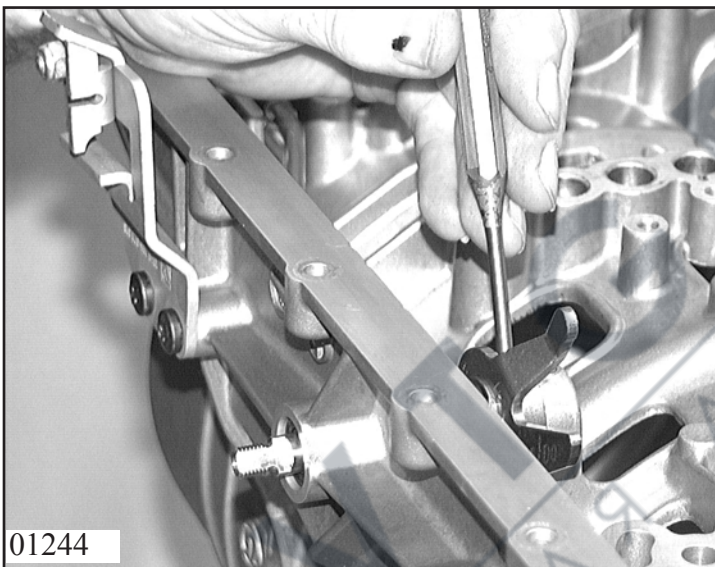

Drive clamping sleeve out of parking disk with a suitable mandrel and pull out selector shaft.  
Remove sleeve and spring.

Next, take out parking disk with connecting rod. Lever out the shaft sealing ring with a screwdriver.  
Loosen the 2 Torx screws for the emergency release angle and take it off.

*(for M Version)*

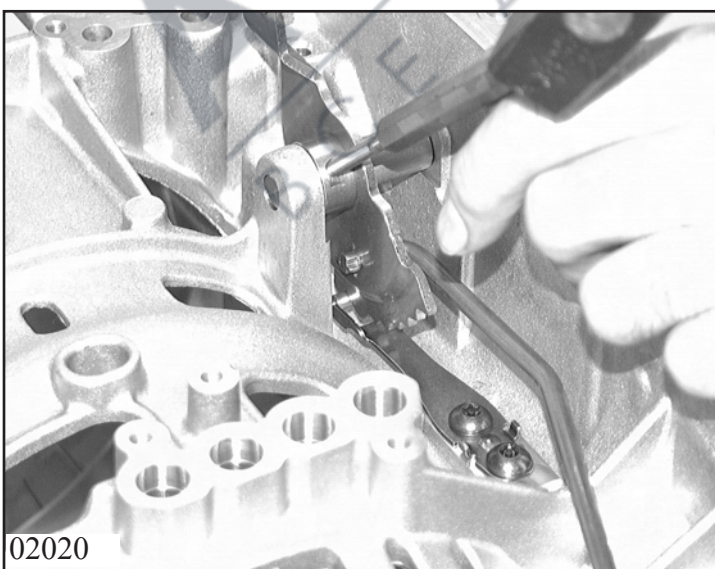

Drive clamping sleeve out of detent disk with a suitable mandrel and pull out selector shaft.  
Remove sleeve.

Next take out the detent disk with connecting rod. Lever out the shaft seal ring with a screwdriver.

The detent spring normally remains in the transmission casing.

To remove it, loosen the two Torx screws.

(Wrench size = Torx - TX 27 H)

Remove screw plug with sealing ring.  
(Wrench size = 6 mm Hexagonal socket)

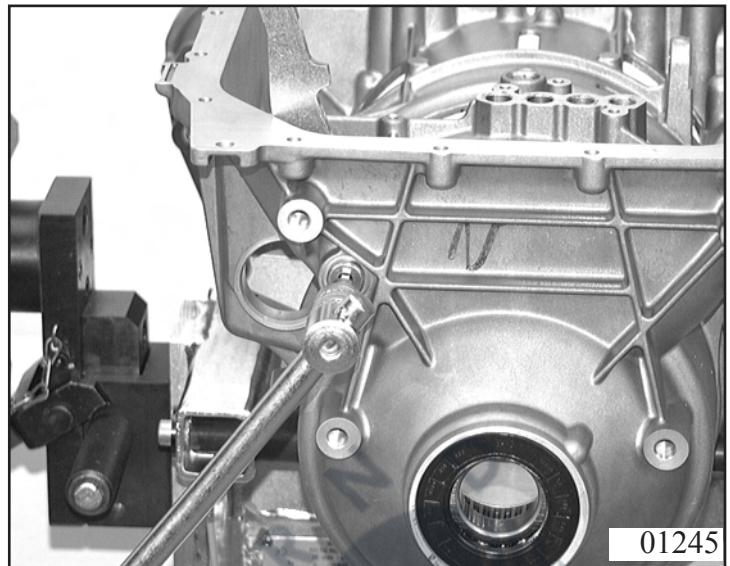

Press pin out of transmission casing. The ratchet with spring can then be taken off.

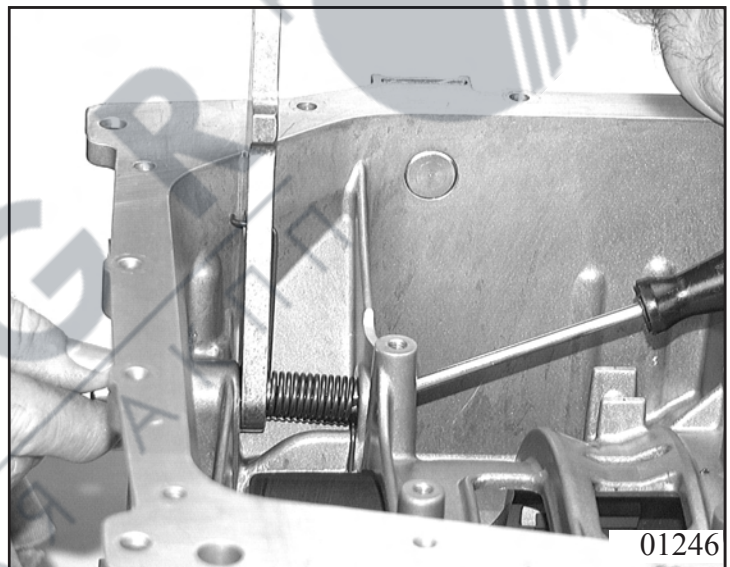

Remove the shaft sealing ring from the transmission casing with a suitable lever.  
Remove the snap ring with pliers.

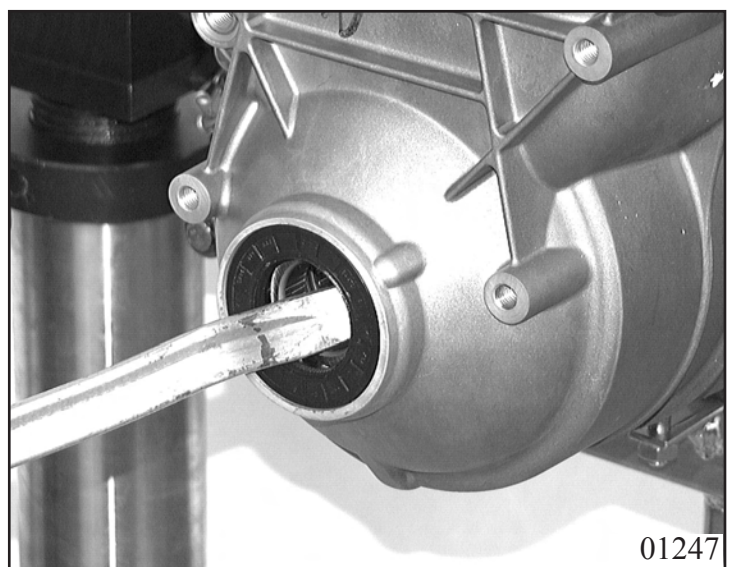



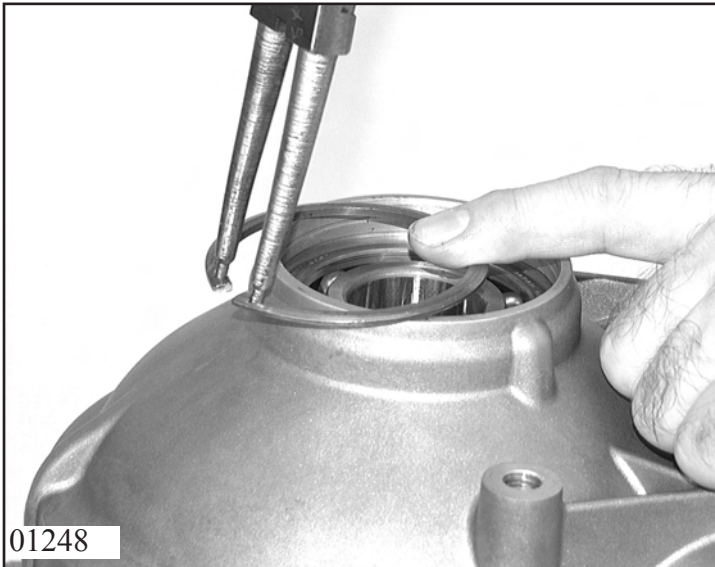

Remove the snap ring with pliers.  
Press the ball bearing out of the transmission casing with a suitable mandrel.

01248

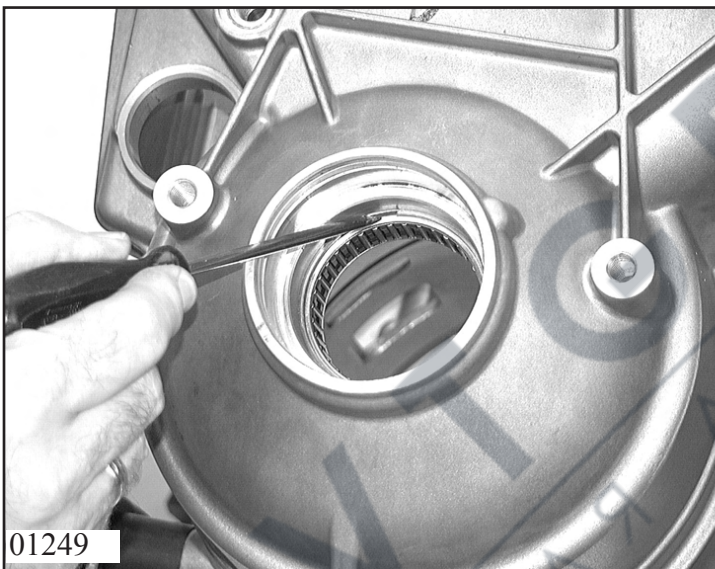

Remove the snap ring with pliers.  
If necessary, heat the casing around the needle roller bearing with a fan heater to 70° C. Turn housing with output side down and remove the needle roller bearing from the transmission casing.

01249

To clean the transmission casing, remove all the screw plugs and caps.

1 screw plug for WK (lock-up clutch) open.  
(Wrench size = 5 mm Hexagonal socket)

Pull 2 plastic drain plugs out of the oil cooler inlet and outlet.

Pull off 1 breather cover.



3. Assembly  
 3.1 Transmission casing with shift control and parking lock

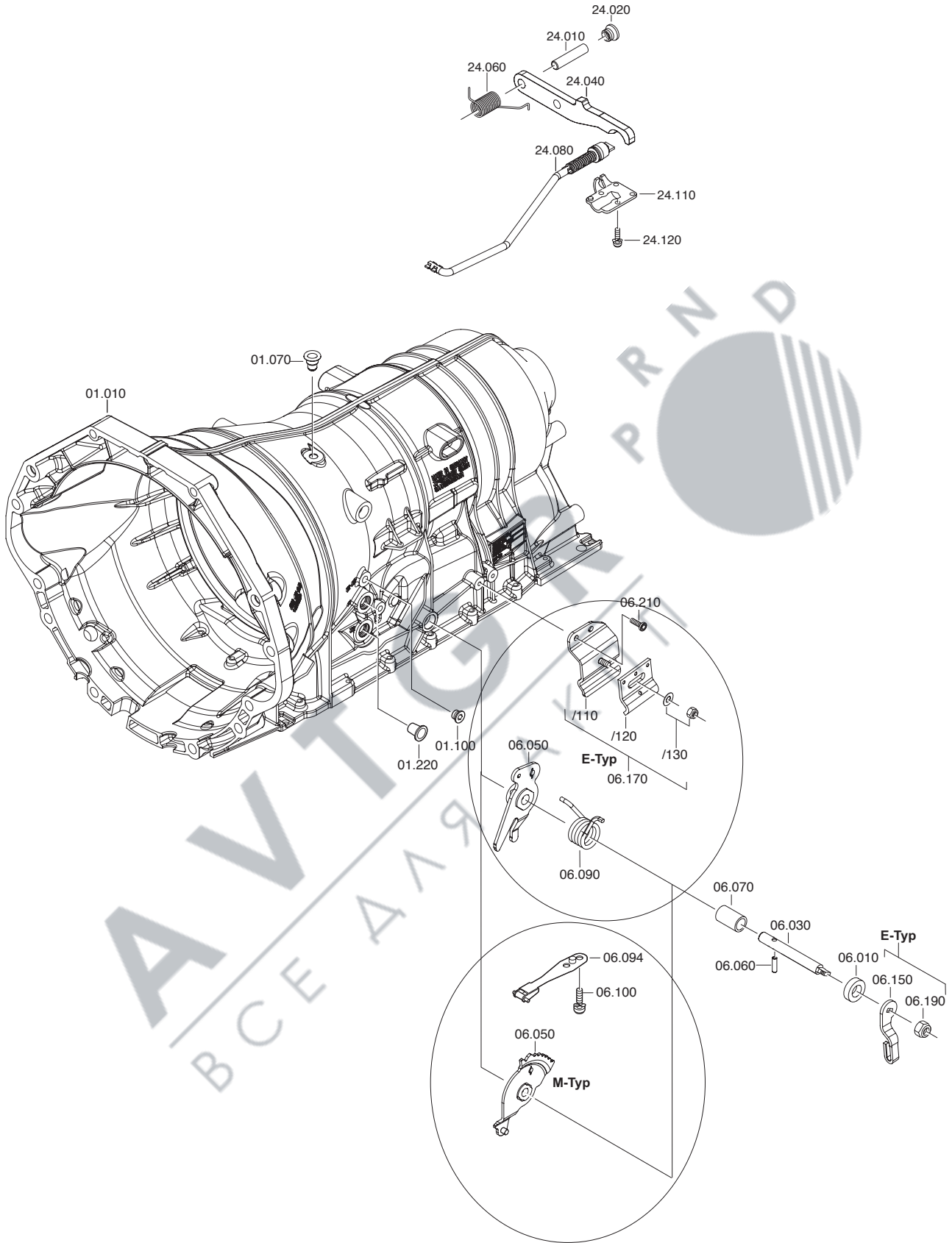

Drive breather tube 01.070 into transmission casing 01.010 with a plastic-faced hammer.

**Warning!**

This is only necessary with a new transmission casing.

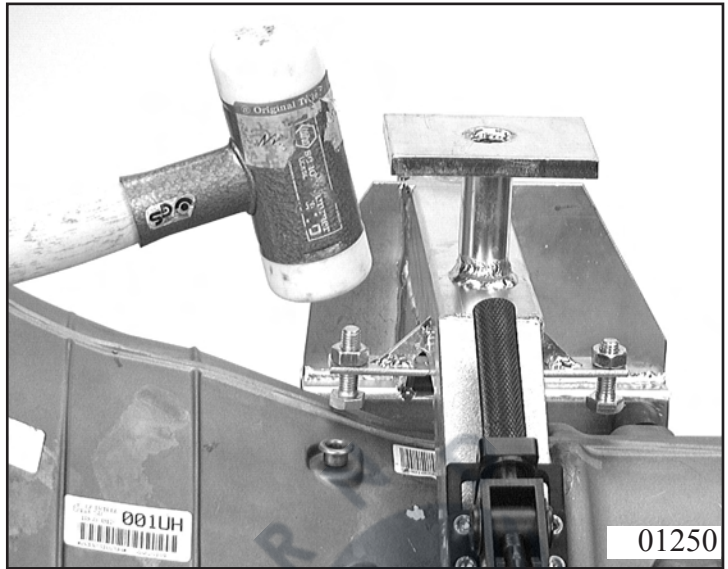

Install shaft sealing ring 06.010 in transmission casing with pressing-in mandrel 5x46 002 561.

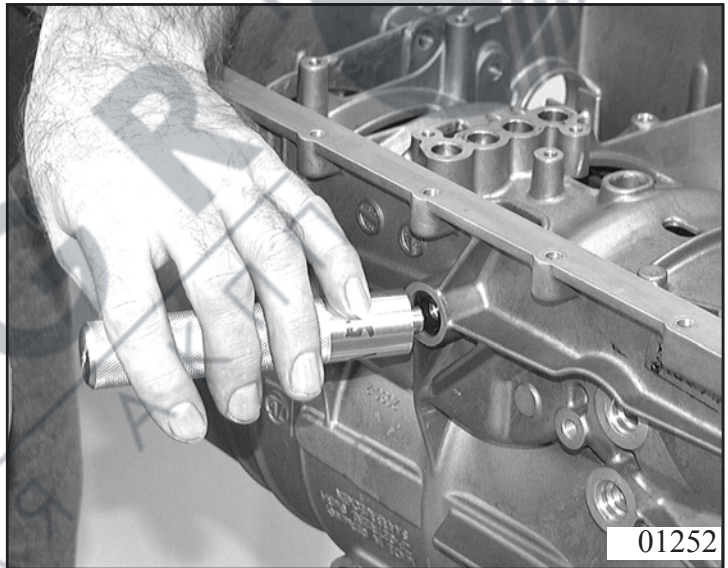

Insert new screw plug 01.100.  
Press in 2 transport plugs 01.220 by hand.

(for tightening torque see Chapter 1.5)

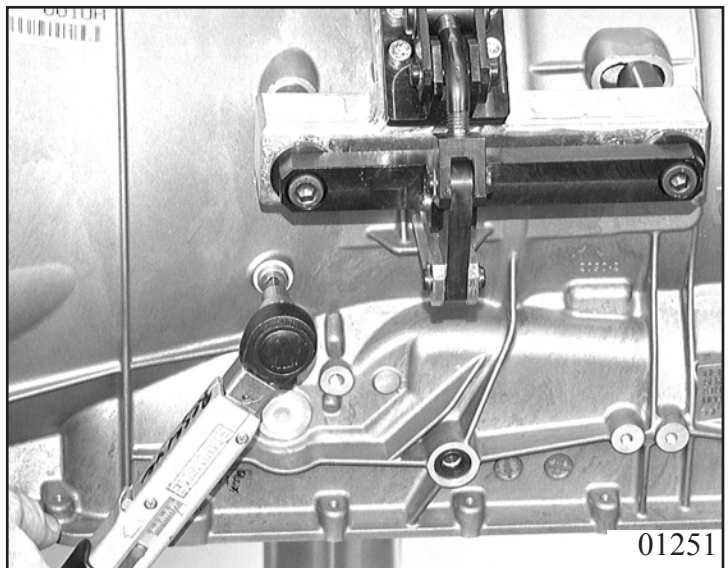

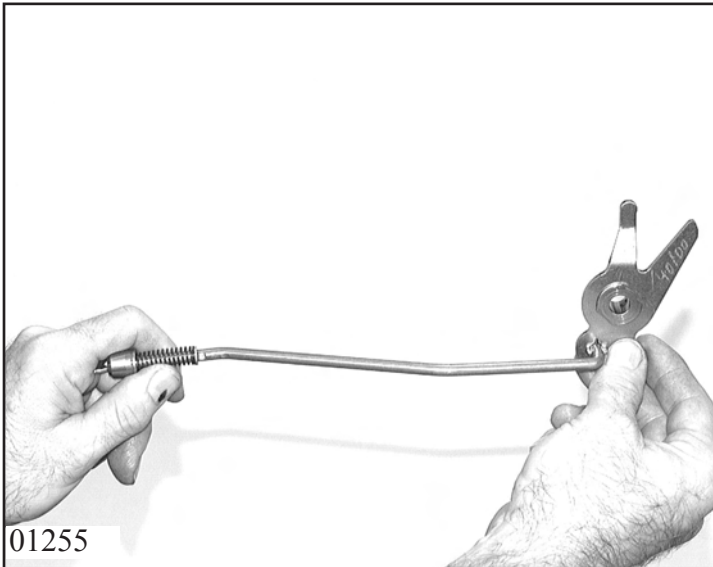

Attach connecting rod 24.080 to parking or detent disk 06.050 and turn to secure.

01255

*(With M type and new housing only)*

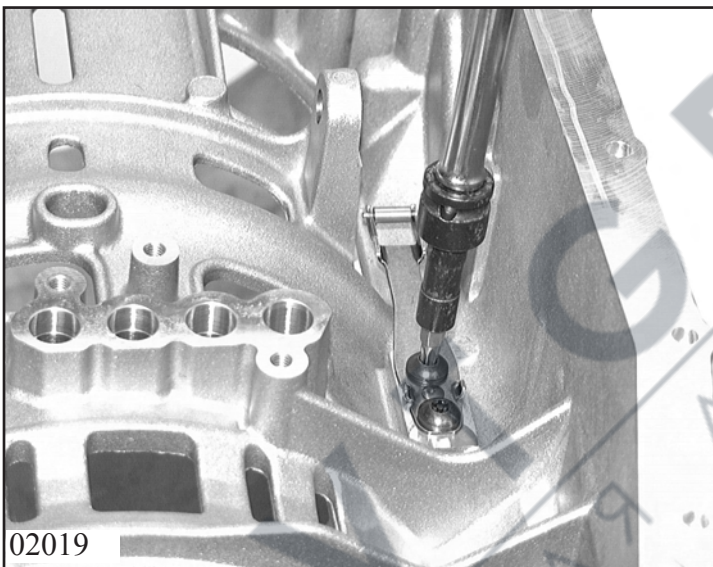

Attach detent spring 06.090 loosely with 2 Torx screws 06.100, so that the detent spring can still be repositioned slightly.

02019

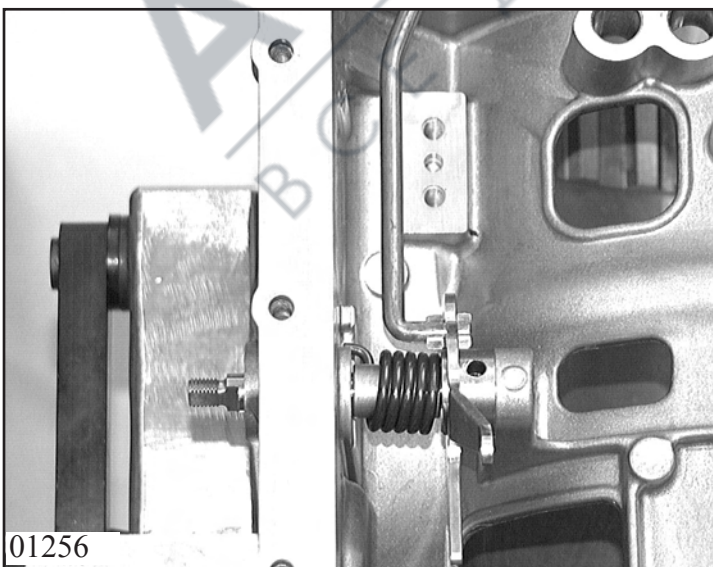

Insert parking or detent disk with connecting rod into transmission casing and push selector shaft 06.030 in through pipe 06.070 and detent disk.

01256

**Warning!**

For the E type, first push spring 06.090 over selector shaft.

*(E type only)*

Drive in new dowel pin 06.060 with striker pin 5x46 000 291 or an appropriate mandrel in the correct position.

**Warning: E type**

Slight spring pre-tensioning is required to permit installation of the parking lock when there is no current flow.

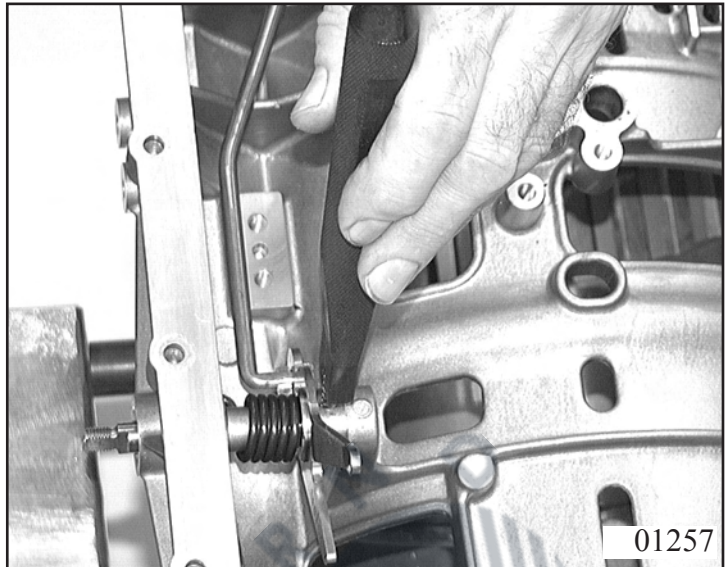

*(M type only)*

Drive in new dowel pin 06.060 with striker pin 5x46 000 291 or an appropriate mandrel in the correct position.

**Warning!**

*With new gearbox housing or new detent spring only;*

**Adjustment required ! Chapter 1.4.8**

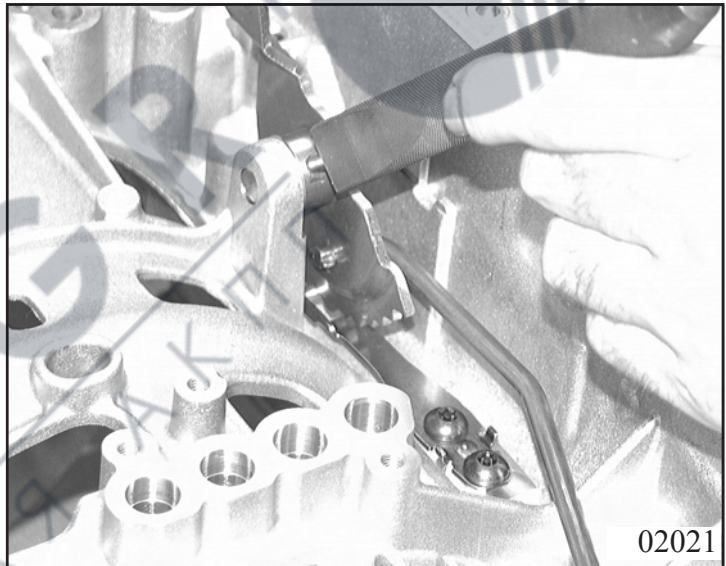

Insert ratchet 24.040 with torsion spring 24.060 into transmission casing and fasten by pressing in pin 24.010. Then close the bore with screw plug and sealing ring 24.020.

*(for tightening torque see Chapter 1.5)*

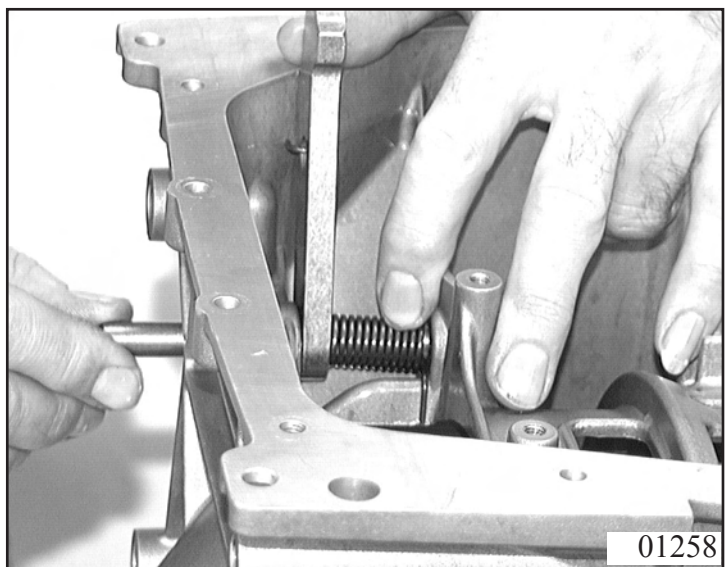

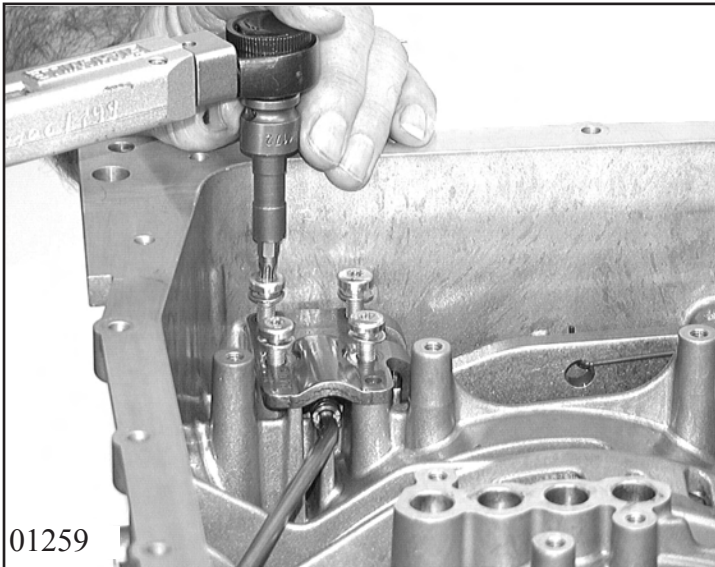

Press down ratchet and fasten guide plate 24.110 with 4 Torx screws 24.120.

(for tightening torque see Chapter 1.5)

*(E type only)*



Attach emergency release angle 06.170 with two Torx screws 06.210  
Fasten lever 06.150 facing the oil pan side with nut 06.190.

(for tightening torque see Chapter 1.5)





### 3.2 Output shaft with parking lock and planetary gear set

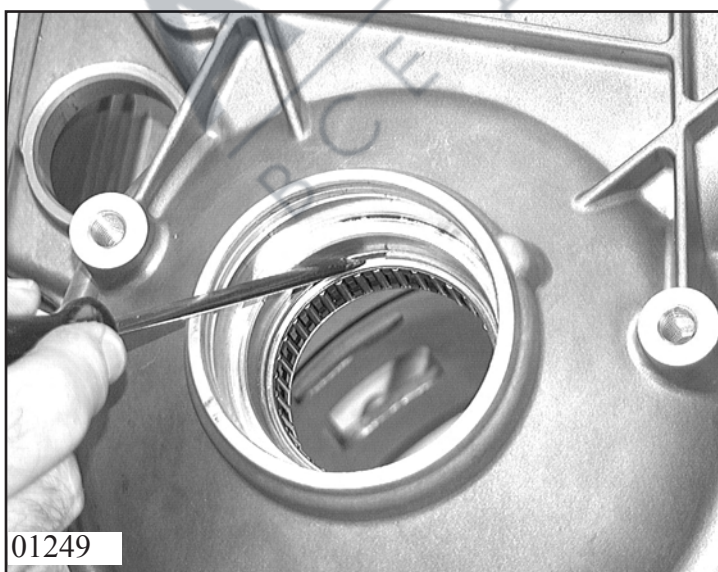
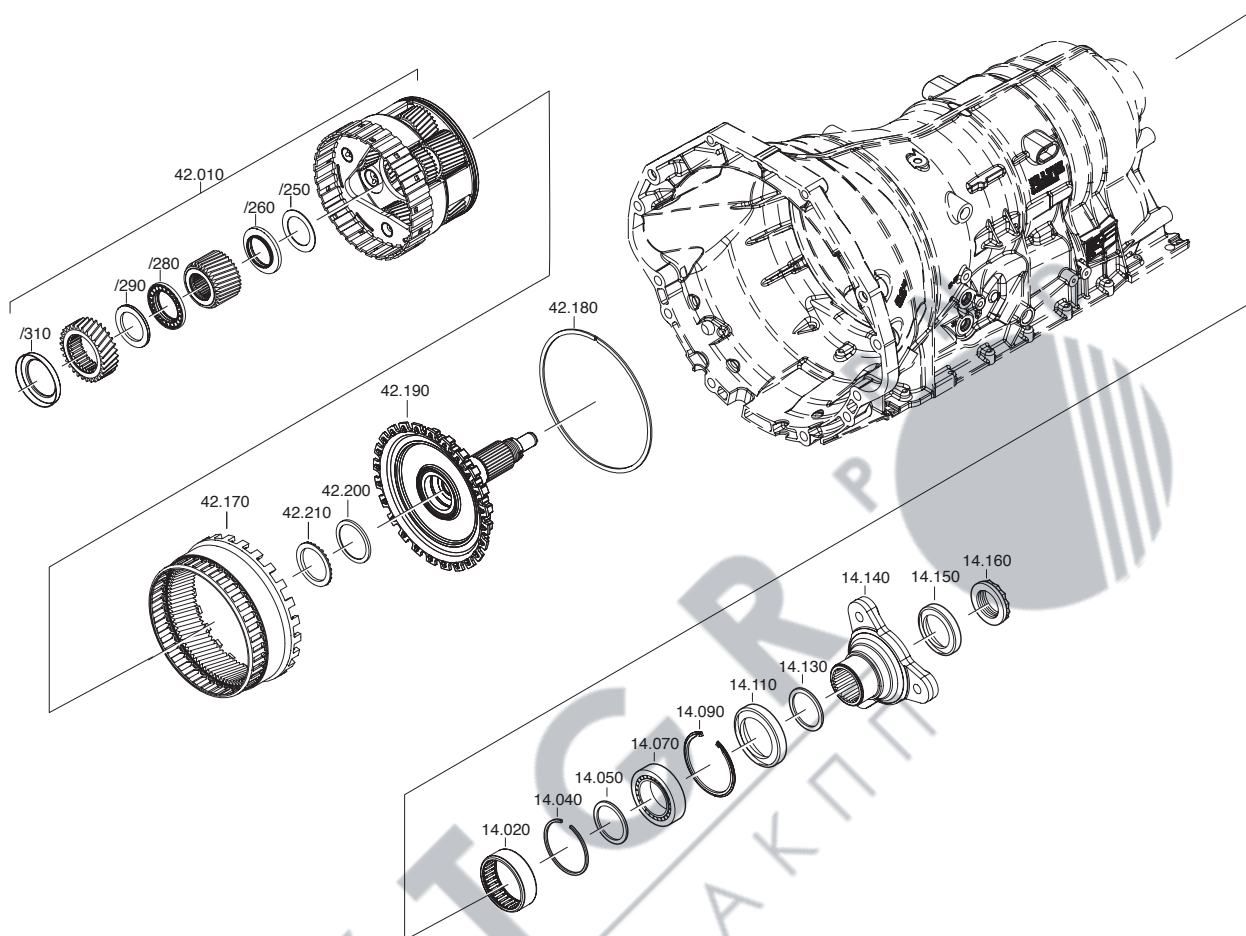

Press needle roller bearing 14.020 into transmission casing using mandrel 5x46 004 373.  
Secure with snap ring 14.040

01249

Press ball bearing 14.070 into transmission casing using mandrel 5x46 004 373 and secure with new snap ring 14.090.

**Warning!**  
Using a new snap ring

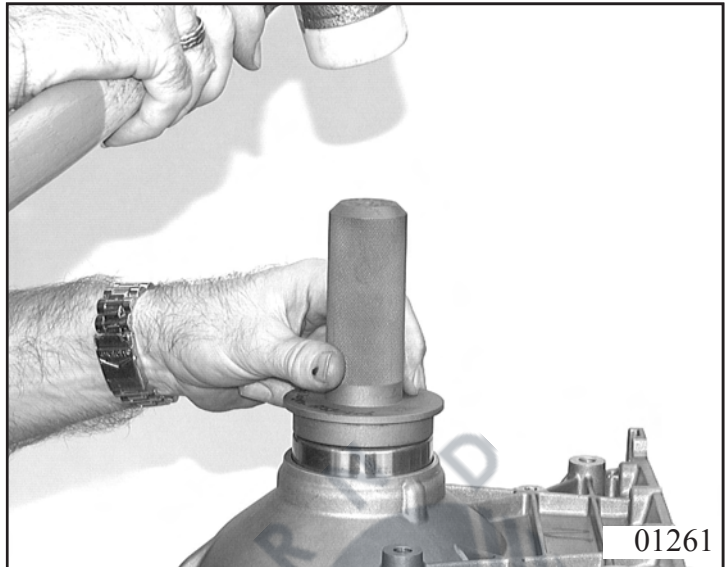

Press shaft sealing ring 14.110 into transmission casing using mandrel 5x46 004 373.

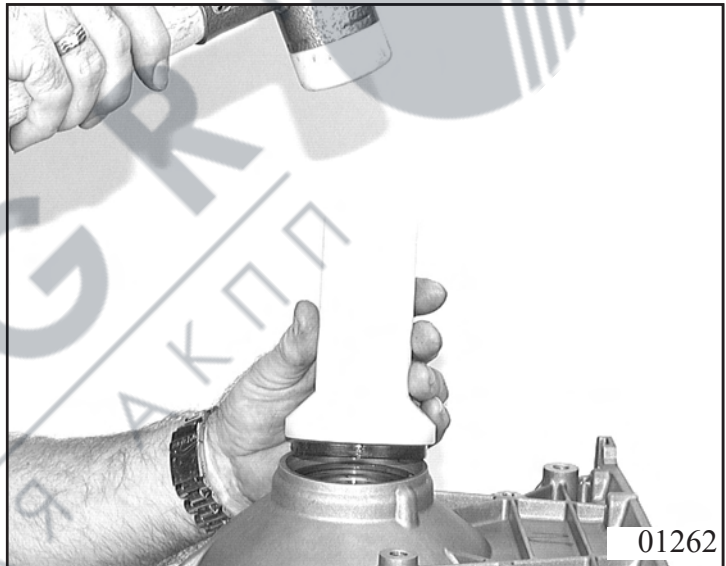

Mount ring gear 42.170 with snap ring 42.180 on output shaft 42.190. Secure compensating washer 14.050 previously removed with grease to the output shaft. Turn the transmission by 90°. Insert output shaft into transmission casing.

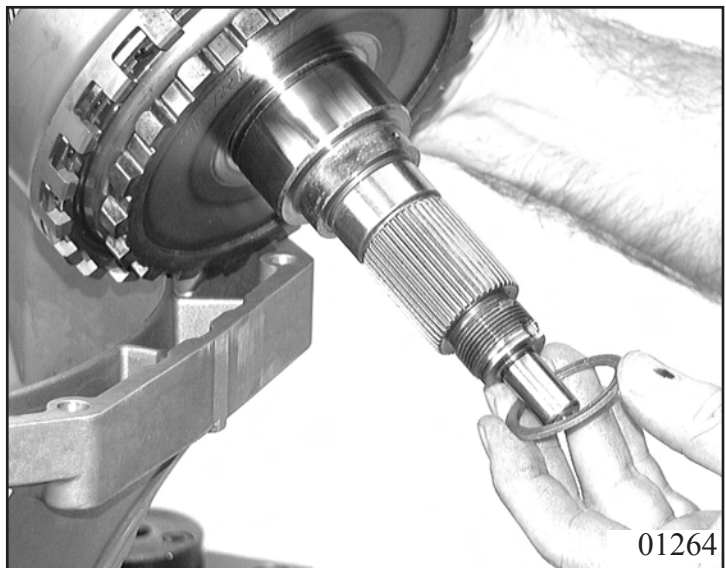

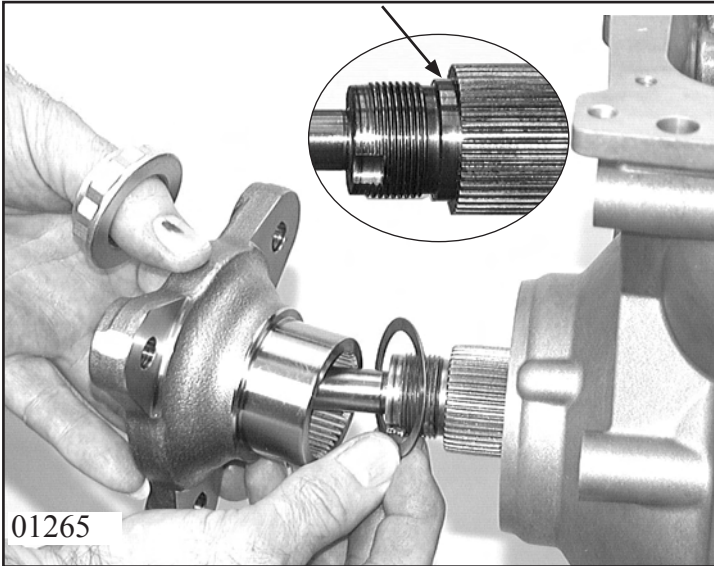

Place reversing disk 14.130 over drive shaft, push flange onto output shaft

(for tightening torque see Chapter 1.5)

**Note:**

For adjusting work, see **Chapter 1.4.6**  
Mount flange with shaft sealing ring only onto output shaft with groove.



Place sealing ring 5x46 012 696 (BMW)/798 (Jaguar) with press-in aid over drive shaft.

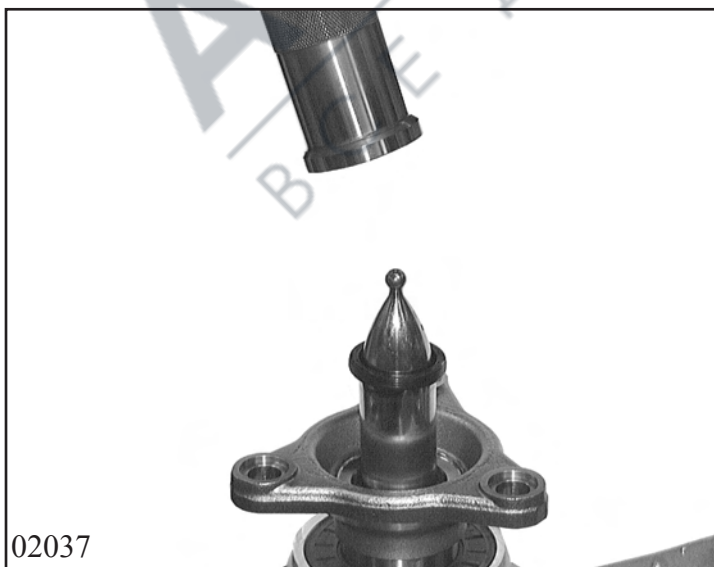

Press shaft sealing ring 14.150 into output flange 14.140 using mandrel 5x46 002 849.

Then tighten flange with collar nut 14.160 using nut 5x46 002 456 and peen it afterwards.

Insert thrust washer 42.010/250 into planetary gear set.  
Clip 2 bearings 42.010/260 + /280 in sun wheel 3 (small) and insert it with phase on top in planetary gear set.

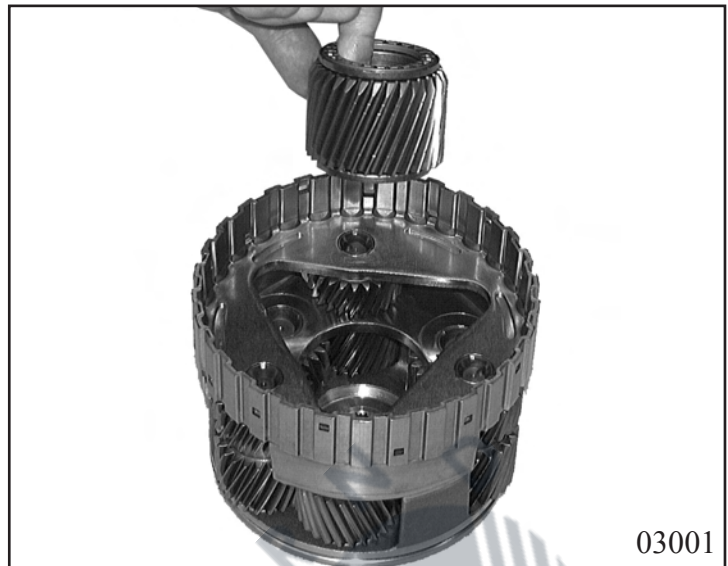

Turn transmission with converter bell upwards.  
Clip bearing 42.210 into planetary gear set 42.010.  
Insert disk 42.200 and planetary gear set into transmission casing.

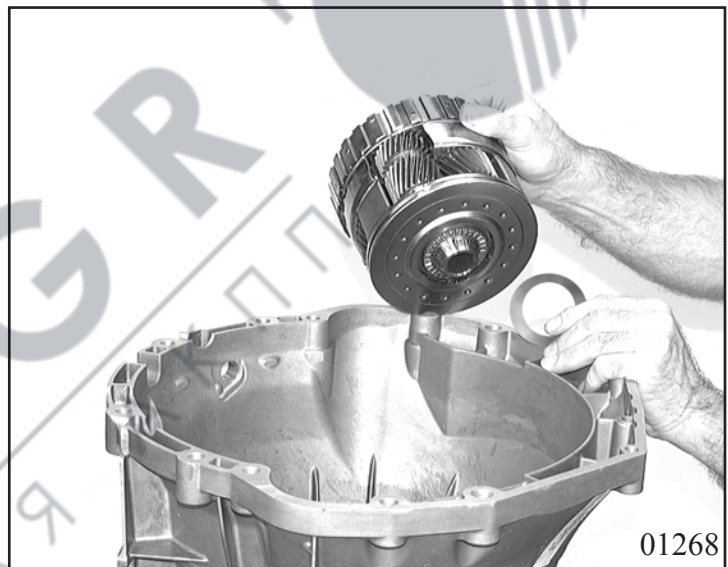

Press-in thrust washer 42.010/290 in sun wheel 2  
Insert sun wheel 2 and angular disk 42.010/310 into planetary gear set.

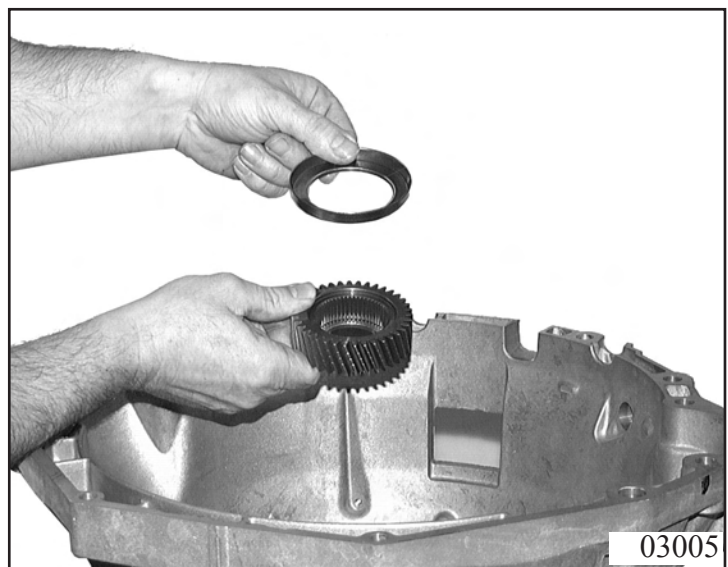

**Warning!**  
Insert sun wheel 2 with large turned groove on top.

### 3.3 Brakes C and D

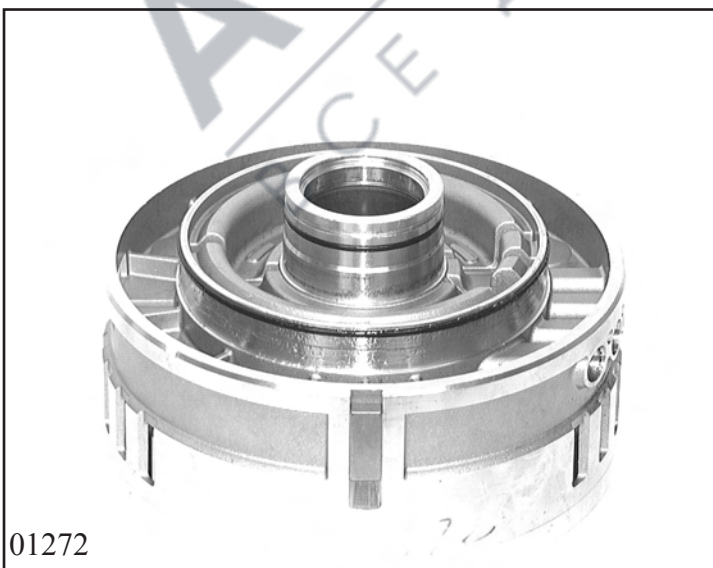
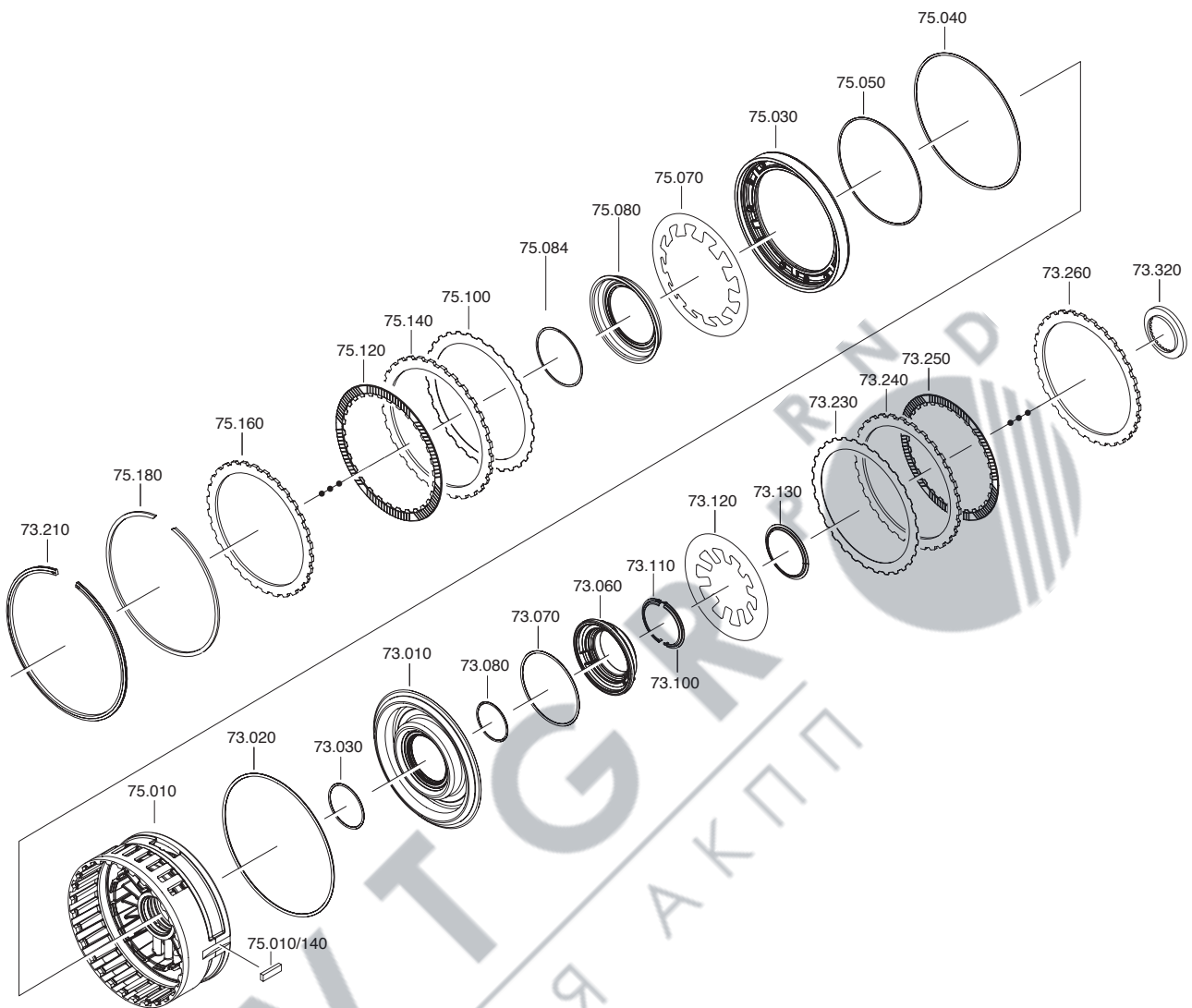

Drive 2 shaft keys 75.010/140 in centrally at cylinder CD 75.010, using a plastic hammer.

Pull 1 O-ring seal 73.030 and 1 lip-type sealing ring 73.020 onto cylinder CD.

Pull 1 O-ring seal 73.080 onto piston D 73.010. Press the piston D into cylinder CD.

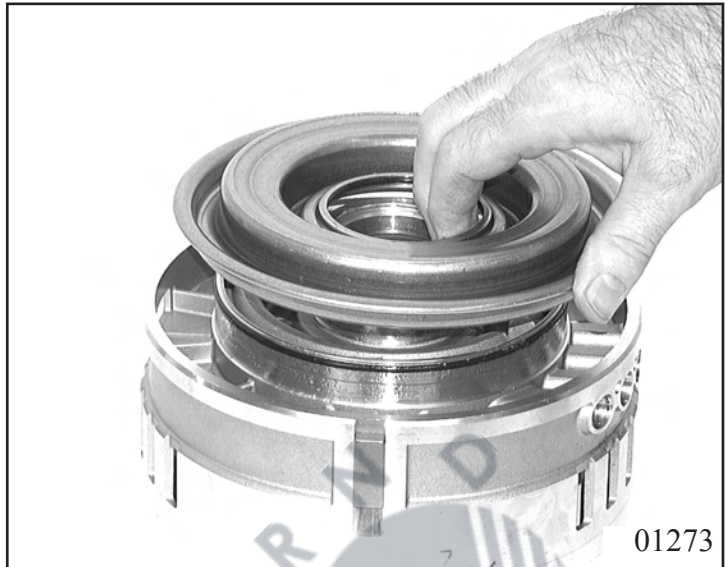

Pull one O-ring seal 73.070 onto baffle plate D 73.060.  
Place the cup spring 73.120 onto the baffle plate with the camber downwards and secure it with the split retaining ring 73.130.

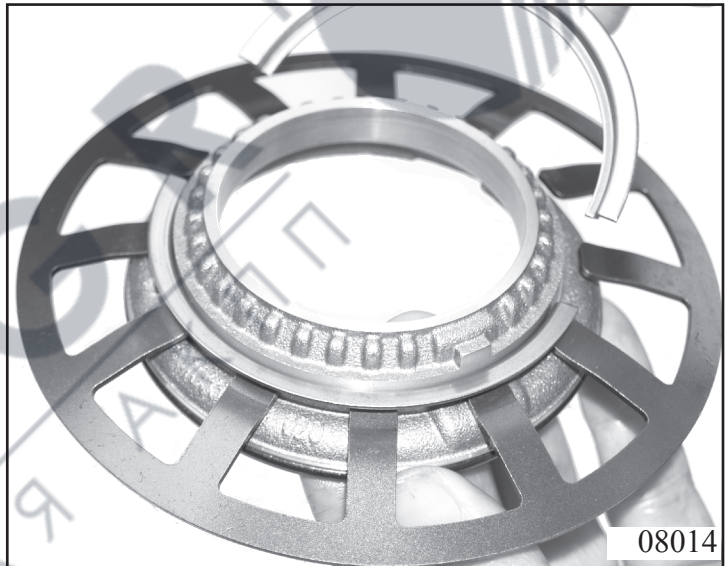

Position the baffle plate with the cup spring with the nose in the slot in the cylinder.  
Press the cup spring down with the fitting bar 5x46 001 500 under the mandrel press and with the split retaining rings 73.100 and 73.110 position it with both the noses in the slot

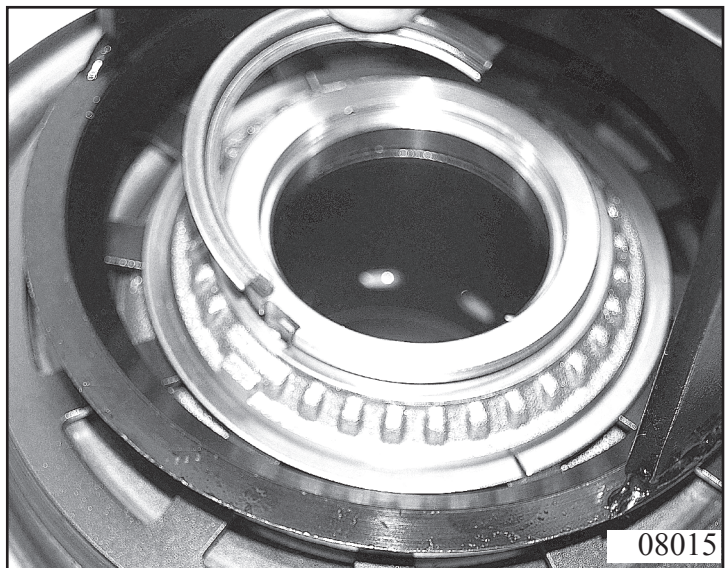



01276

Pull two lip sealing rings 75.040 and 75.050 onto the piston C 75.030. Oil the lip sealing rings lightly and set the piston straight and press it carefully into the cylinder.

**Warning!**

The piston has to be inserted in an horizontal way, not wedged. If canted, the lip sealing ring may be crushed.

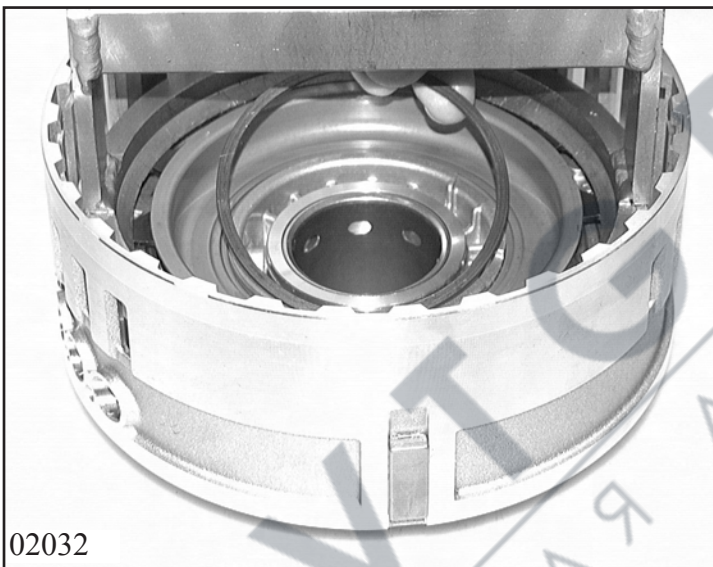

02032

Insert cup spring C 75.070 and retaining ring 75.080.

Press down cup spring C in the mandrel press with assembly bracket 5x46 001 501 and secure with snap ring 75.084.



01281

Insert complete clutch pack C into cylinder CD, starting with spring disk 75.100. Then insert an outer disk 75.140 and a lined disk 75.120 alternately.

Secure the top outer disk 75.160 with snap ring 73.180.

**Note:**

For adjusting work see **Chapter 1.4.1**

Turn cylinder CD and clip axial needle bearing 75.240 into position at the cylinder web (brake D side).

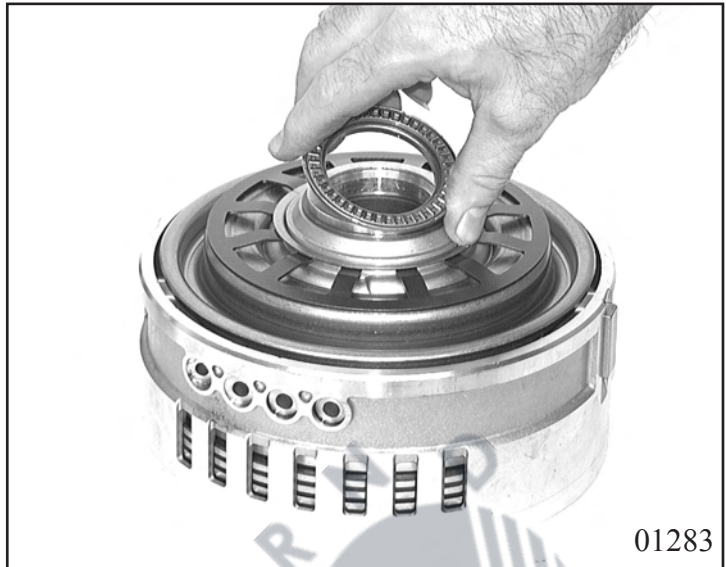

Insert complete clutch pack D into housing, starting with final disk 73.260, then insert lined disk 73.250 and external disk 73.240 alternately. Complete with spring disk 73.230.

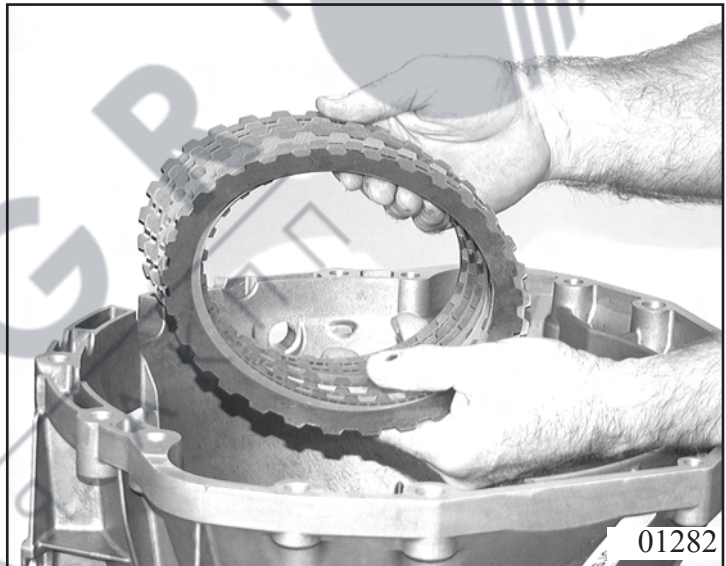

**Note:**  
For adjusting work see **Chapter 1.4.3**

Insert complete cylinder CD in transmission housing.

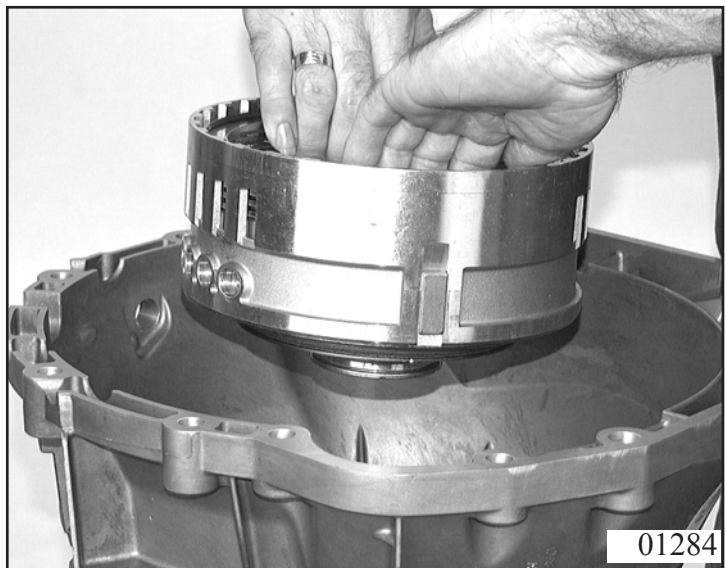



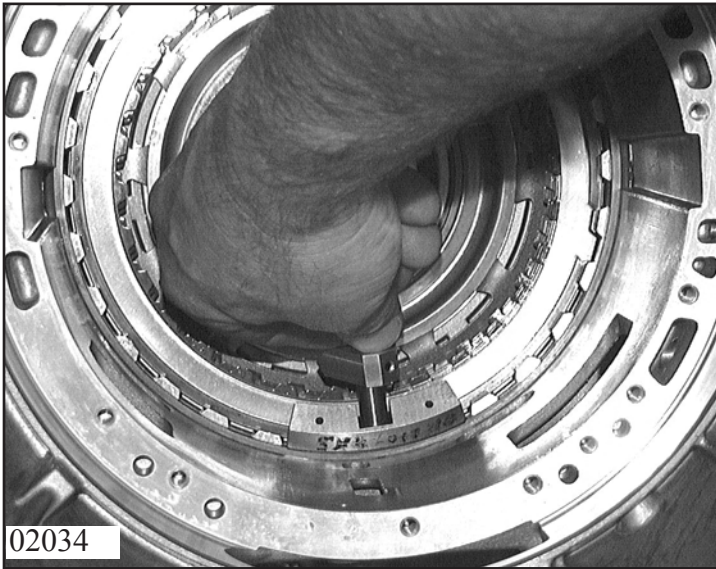

Secure with snap ring 75.260.  
Use driving-in tool 5x46 001 930 to drive  
the snap ring into the housing groove all  
round.

**Note**  
Dismount the handle of the tool for a  
better usability.

AVTGR  
ВСЕ ДЛЯ АКПП  
P  
D



### 3.4 Clutch B

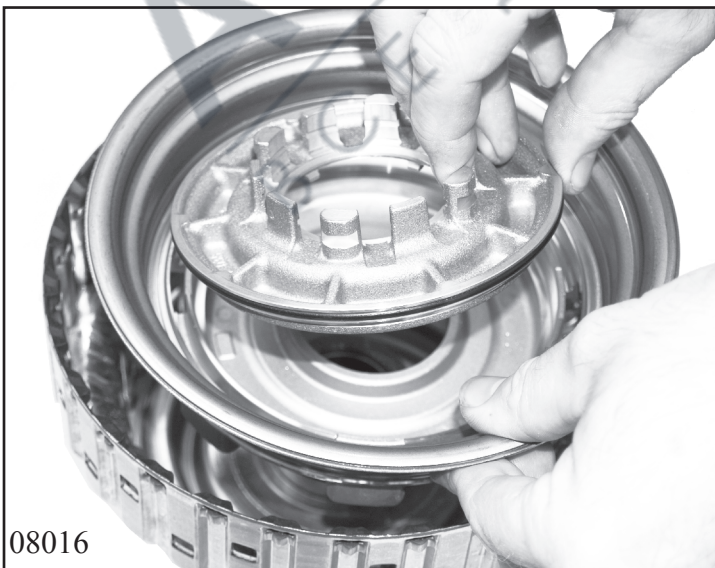
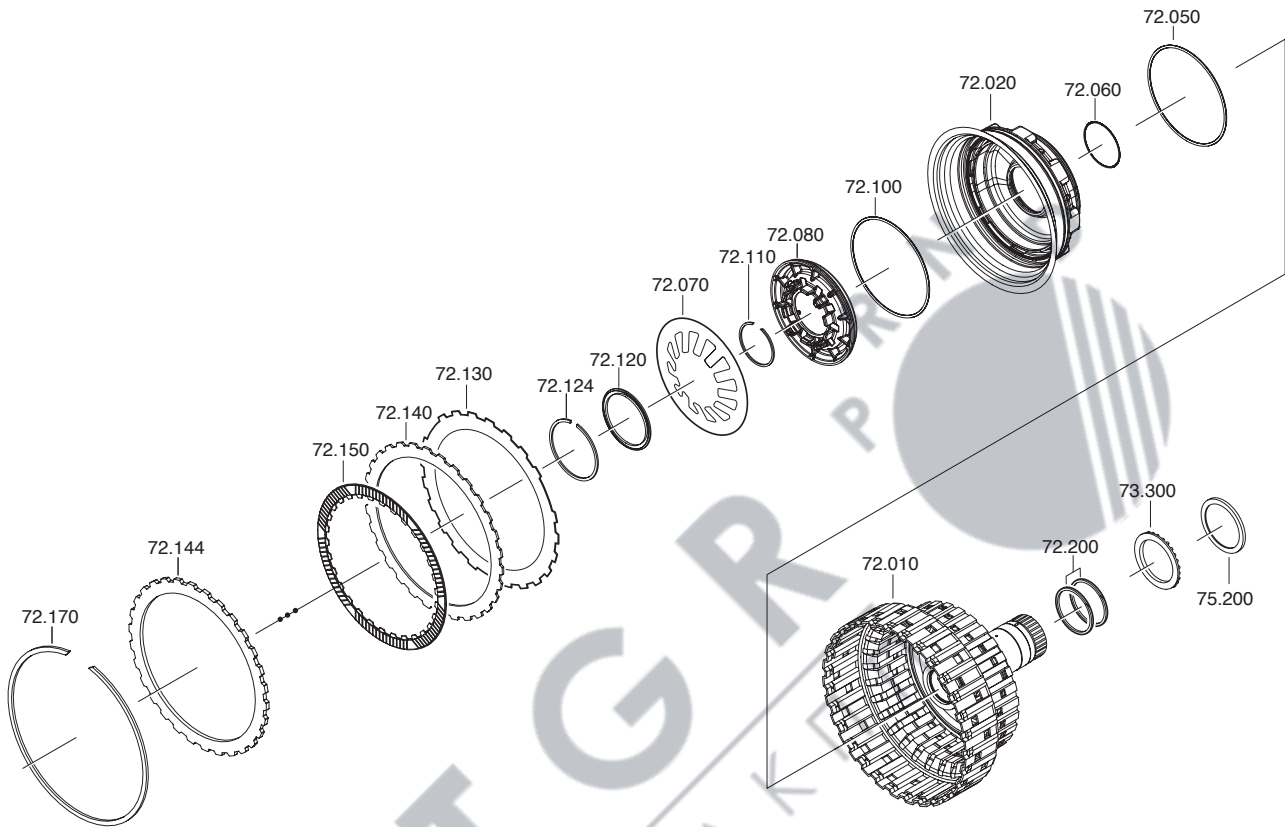

Install new O-ring seals 72.050 and 72.060 on piston B 72.020.  
Press piston into cylinder B 72.010.  
Pull O-ring seal 72.100 onto baffle plate 72.080 and press this into the piston.

08016

Press down the baffle plate and secure with new snap ring 72.110.  
Insert cup spring B 72.070 and retaining ring 72.120 with groove facing upwards.  
Press cup spring down in the mandrel press with assembly hoop 5x46 001 502 and secure with new snap ring 72.124.

**Warning!**

Using 2 new snap rings

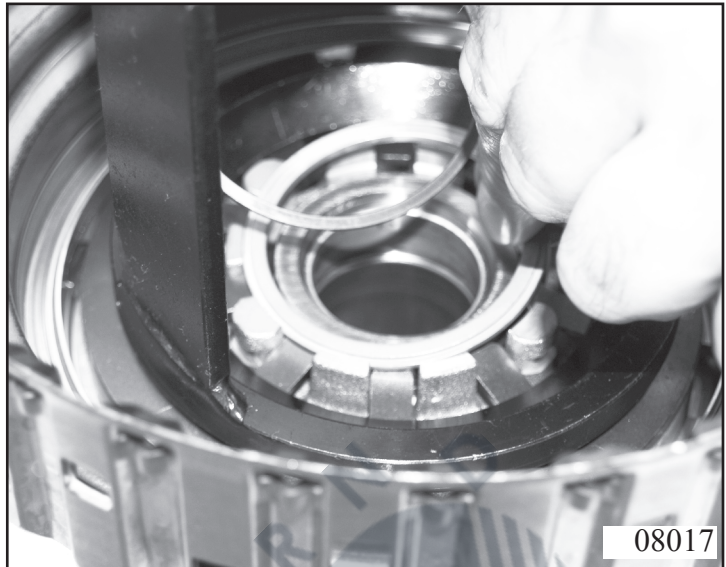

Insert the complete clutch pack B, starting with the spring disk 72.130. Then insert the outer disk 72.140 and the lined disk 72.150 alternately.  
Insert the end disk 72.144 with the knobs upwards and secure it with the snap ring 72.170.

**Warning!**

For adjusting work see **Chapter 1.4.3**



Turn the cylinder and pull 2 rectangular-section rings 72.200 onto cylinder B.  
Clip bearing 72.300 onto cylinder B.

**Warning!**

Secure new rectangular-section rings in the groove with Vaseline.

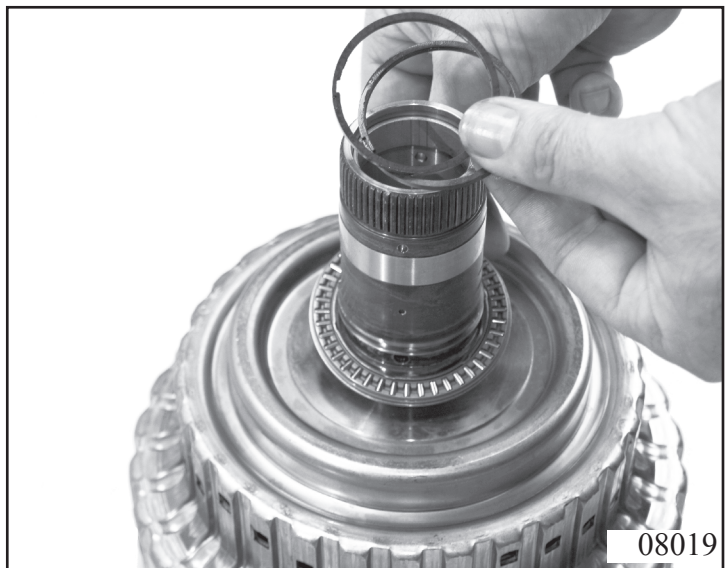

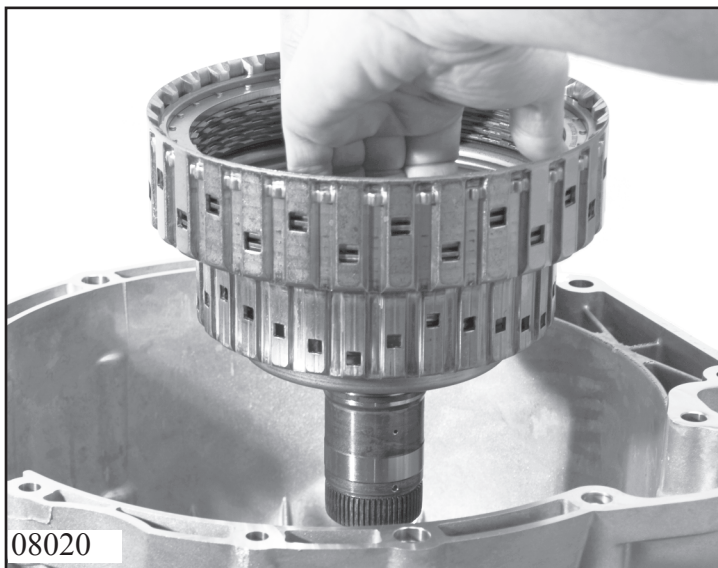

Insert angular disk 75.200 in cylinder CD and also complete clutch B into transmission housing.





### 3.5 Turret (drive with clutches A and E)

#### 3.5.1 Clutch E (drive)

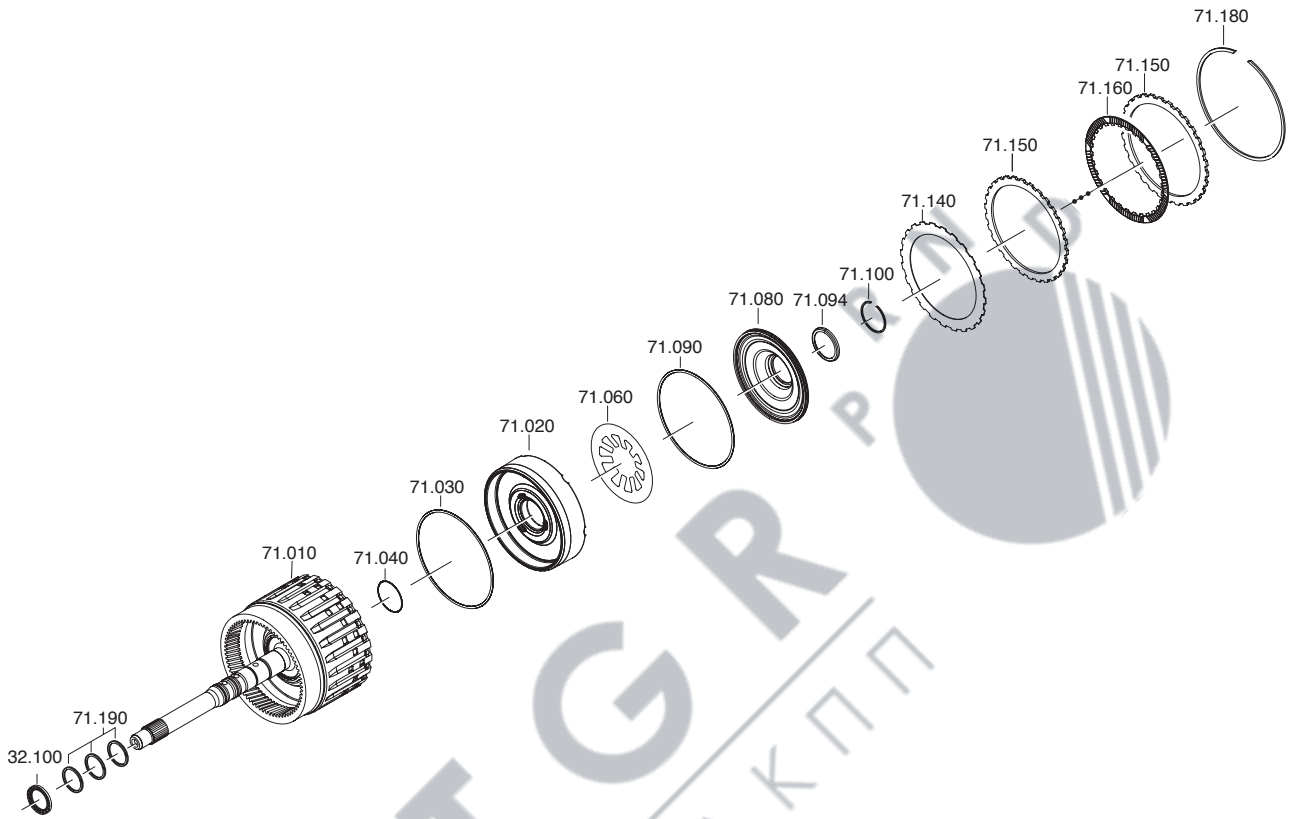

Pull 3 new rectangular-section rings 71.190 onto cylinder E 71.010 with input shaft.

Clip axial needle roller bearing cage 32.100 into cylinder (ring gear side).

Pull new seal rings 71.030 and 71.040 onto piston E 71.020.  
Press piston E into cylinder E.

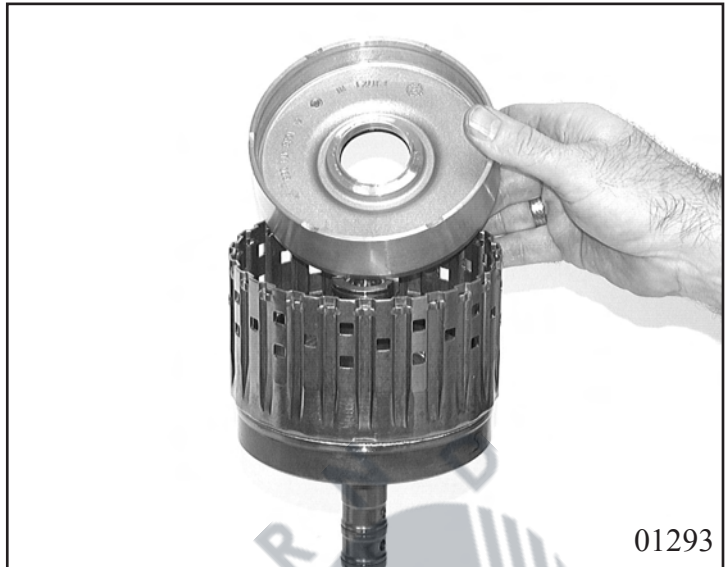

Pull new O-ring seal 71.090 onto baffle plate 71.080. Insert cup spring 71.060 into cylinder E with the projections facing downwards and press in the baffle plate.

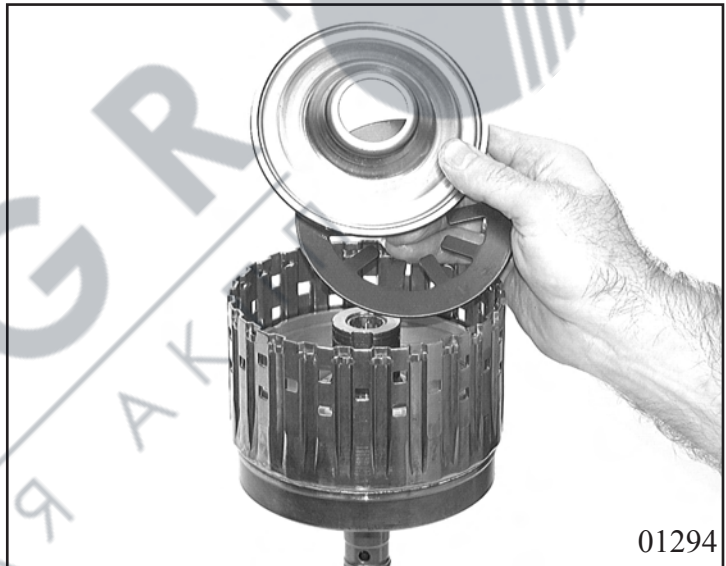

Insert fixing plate 71.094 with groove facing upwards.  
Attach assembly tool 5x46 012 571 and push on snap ring 71.100. Press down tube section 5x46 002 571 with new snap ring and cup spring in the mandrel press until the snap ring engages in the slot.

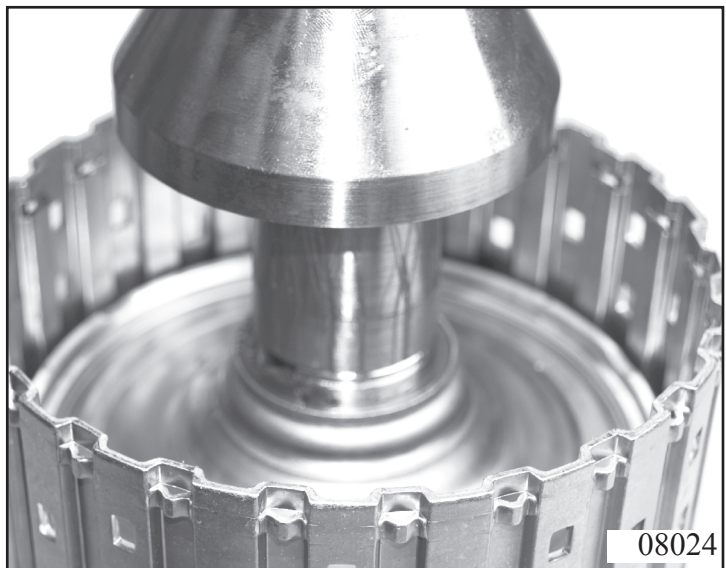

**Warning!**  
Using new snap ring



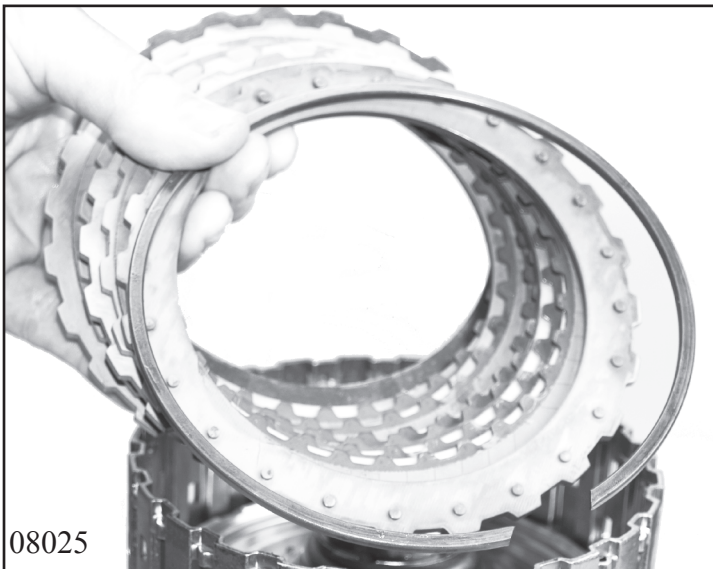

08025

Insert the complete clutch pack E. Start with the spring disk 71.140, then insert the outer disk 71.150 and the lined disk 71.160 alternately.

Insert the end disk 71.150 with the knobs upwards and secure it with the snap ring 71.180.

**Warning!**

For adjusting work see **Chapter 1.4.5**



### 3.5.2 Clutch A (input)

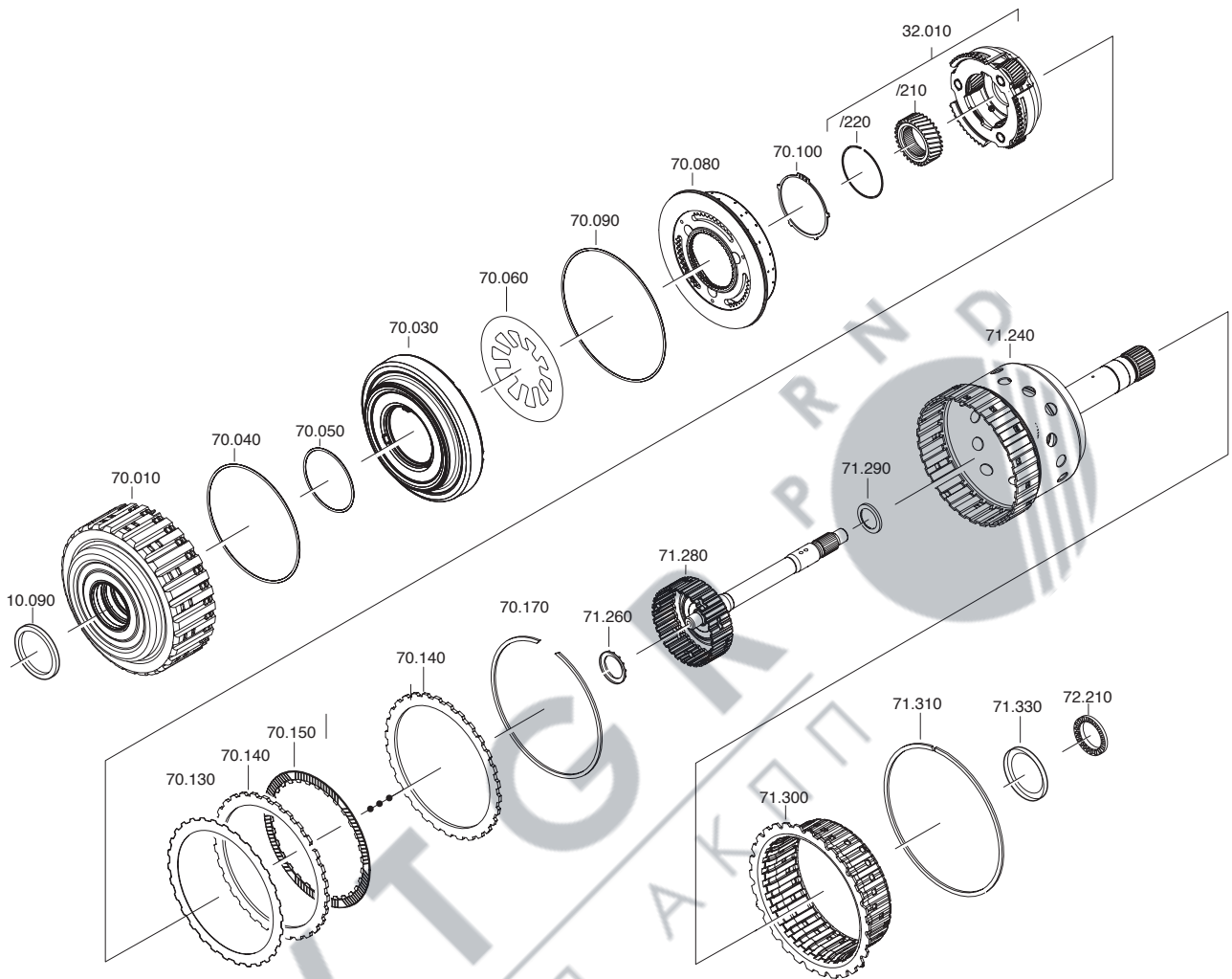

Pull 1 O-ring seal 70.050 and 1 prof. seal ring 70.040 onto piston A 70.030.  
Press piston A into cylinder A 70.010.

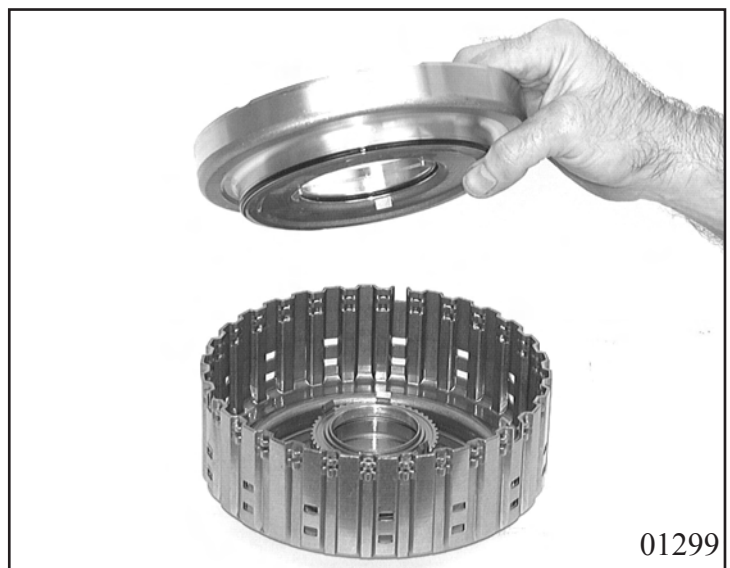

01299

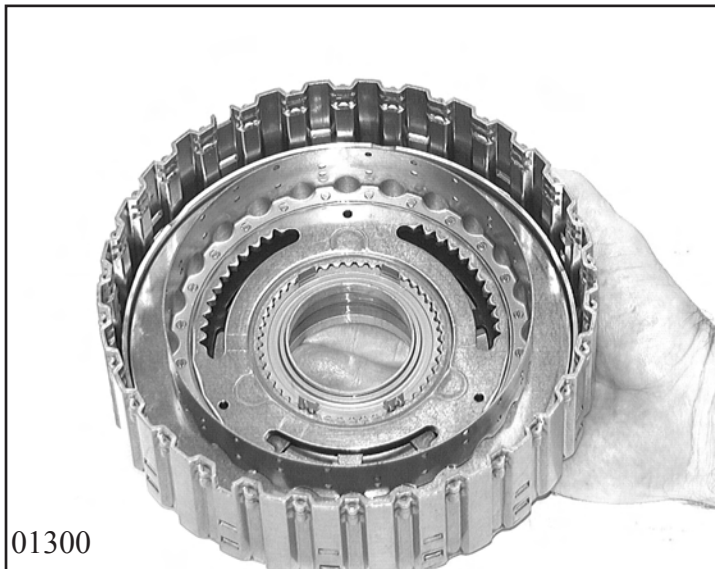

01300

Insert cup spring 70.060.  
Pull prof. seal ring 70.090 onto baffle plate 70.080 and insert the baffle plate into the cylinder in such a way that a drilled hole is located in the center between a pair of projections on the cylinder.

Press the cup spring down in the mandrel press with assembly bracket 5x46 001 500 and secure with k-ring 70.100.

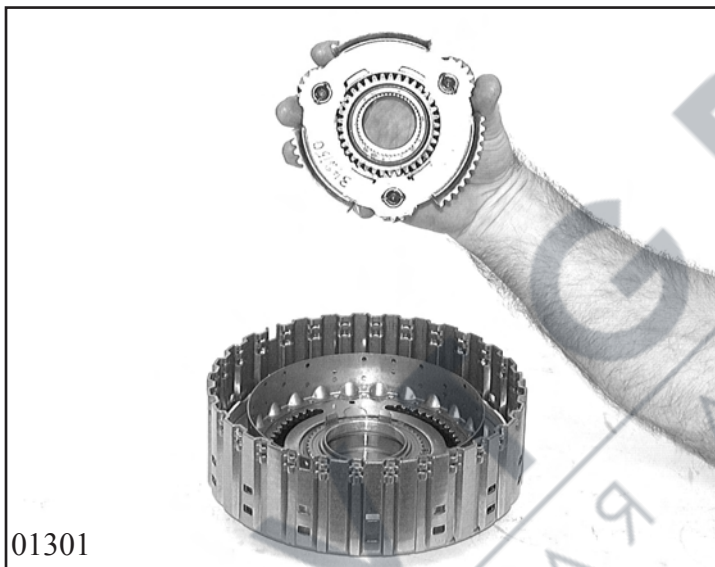

01301

Insert sun wheel 32.010/210 and new snap ring 32.010/220 into planetary gear set 32.010.

Engage complete planetary gear set in position on cylinder A.  
Insert oil tray 32.200.

**Warning!**

Using a new snap ring

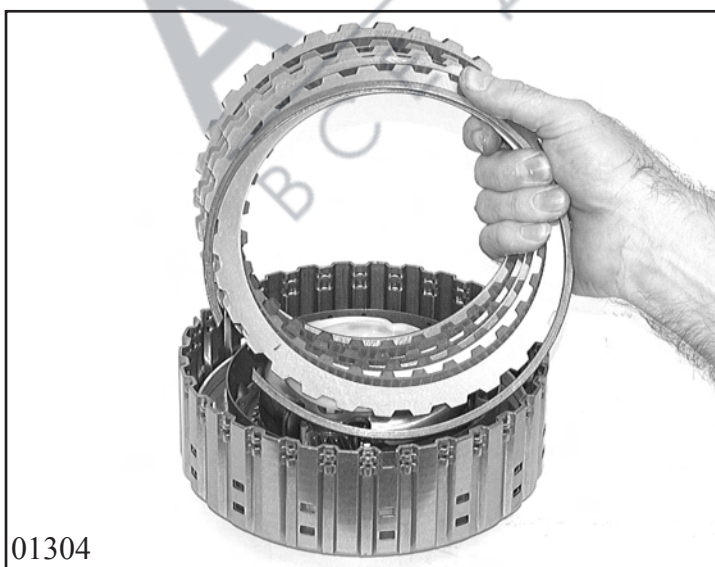

01304

Insert complete clutch pack A. Start with spring disk 70.130, then insert outer disk 70.140 and lined disk 70.150 alternately.  
Secure the top outer disk 70.140 with snap ring 70.170.

**Note:**

For adjusting work, see **Chapter 1.4.4**

Insert complete clutch E in clutch A.  
Clip axial needle roller bearing 32.100  
onto hub of cylinder E.  
For installed position of bearing, see pic-  
ture alongside.

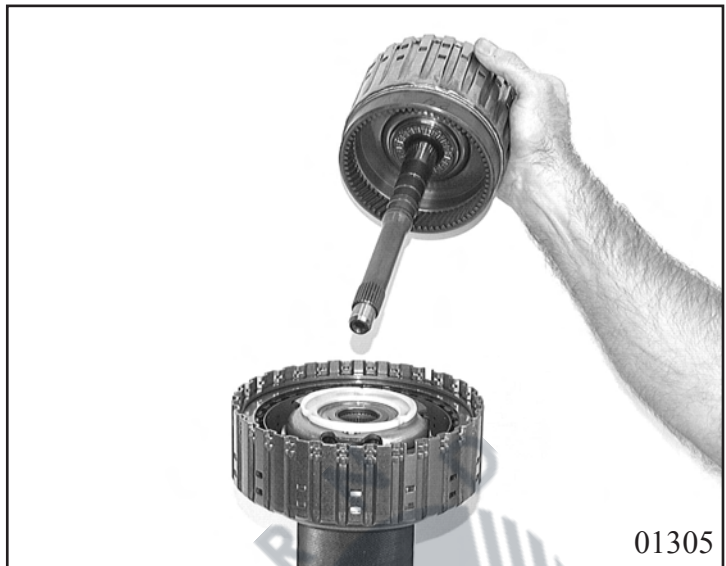

Align disks of clutches A and E.  
Clip axial needle Bearing 71.260 into  
input shaft.  
Insert intermediate shaft 71.280, turning  
it while doing so.  
Clip axial needle bearing 71.290 into sun  
wheel 71.240.  
Insert sun wheel shaft, turning it while  
doing so.

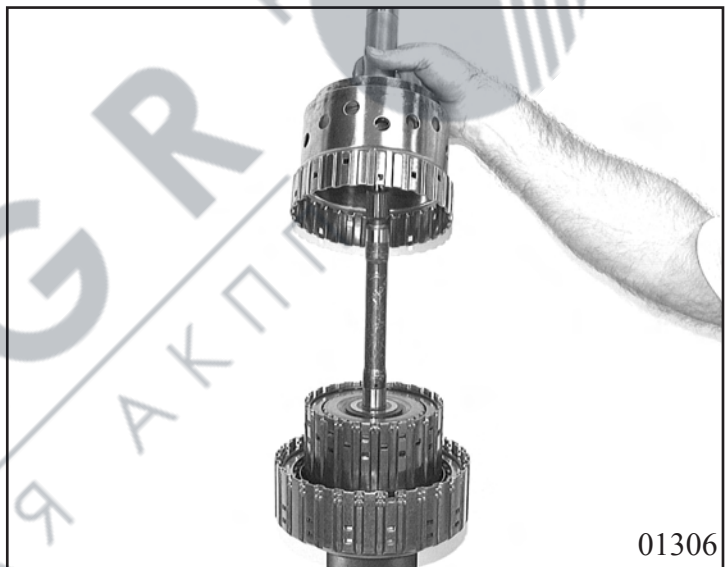

Insert inside disk carrier B 71.300 in cyl-  
inder A and insert new snap ring 71.310.  
Clip the snap ring into both knobs of the  
sun shaft with pincers 5x46 003 981.  
Clip the angle disk 71.330 onto the sun  
shaft.



**Warning!**  
Use a new snap ring

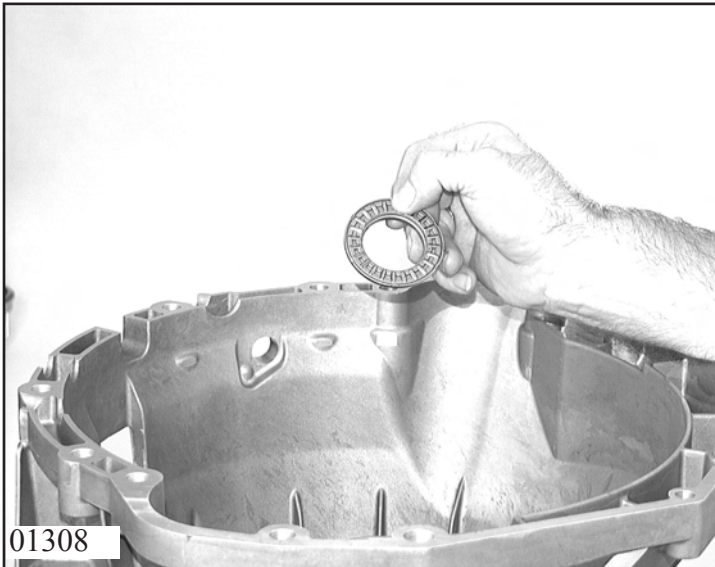

Place axial needle roller cage 72.210 on the hub of cylinder B.  
Note correct installed position of bearing, see picture alongside.

01308

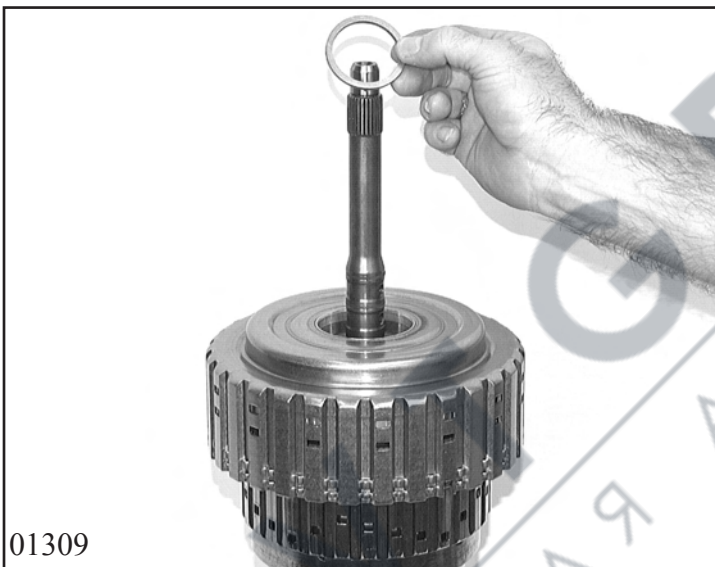

Turn the turret by 180° in the fixture.  
Place compensating washer 10.090 (previously removed) over the input shaft and onto cylinder A.

01309

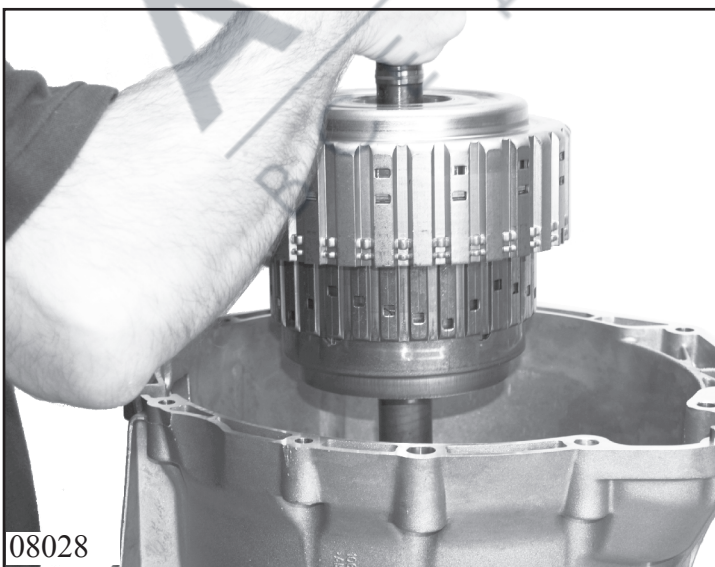

Align disks of clutch B, insert turret by hand and turning it in both directions until the disks engage fully in disk carrier B.

08028

**Check measurement:**

Upper edge of cylinder A to oil supply sealing face approx. 12 mm.

**Note:**

This measurement does not include the thickness of the measuring bar.

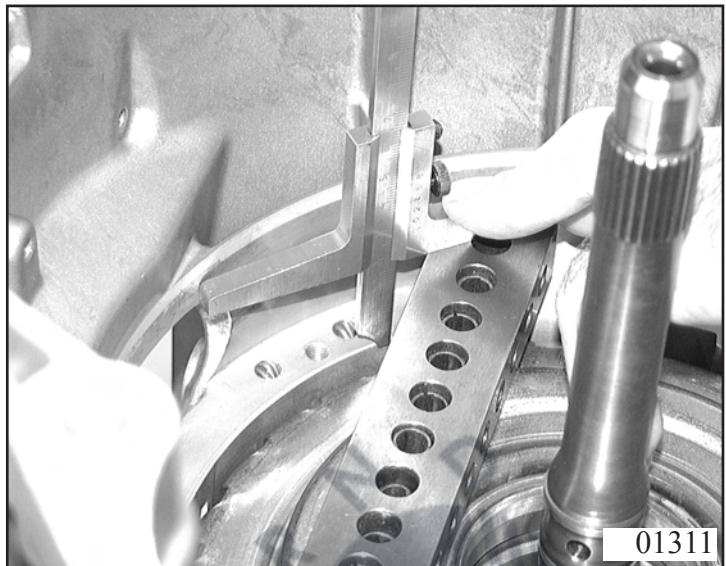

AVTGR  
ВСЕ ДЛЯ АКПП

### 3.6 Oil supply

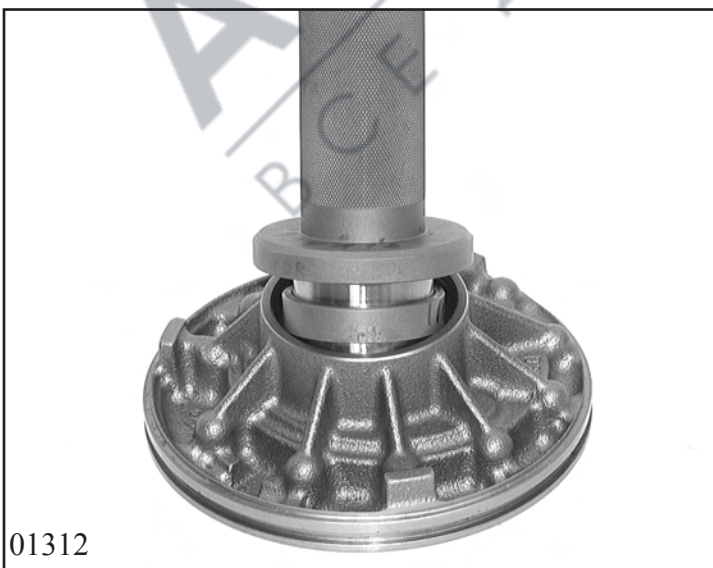
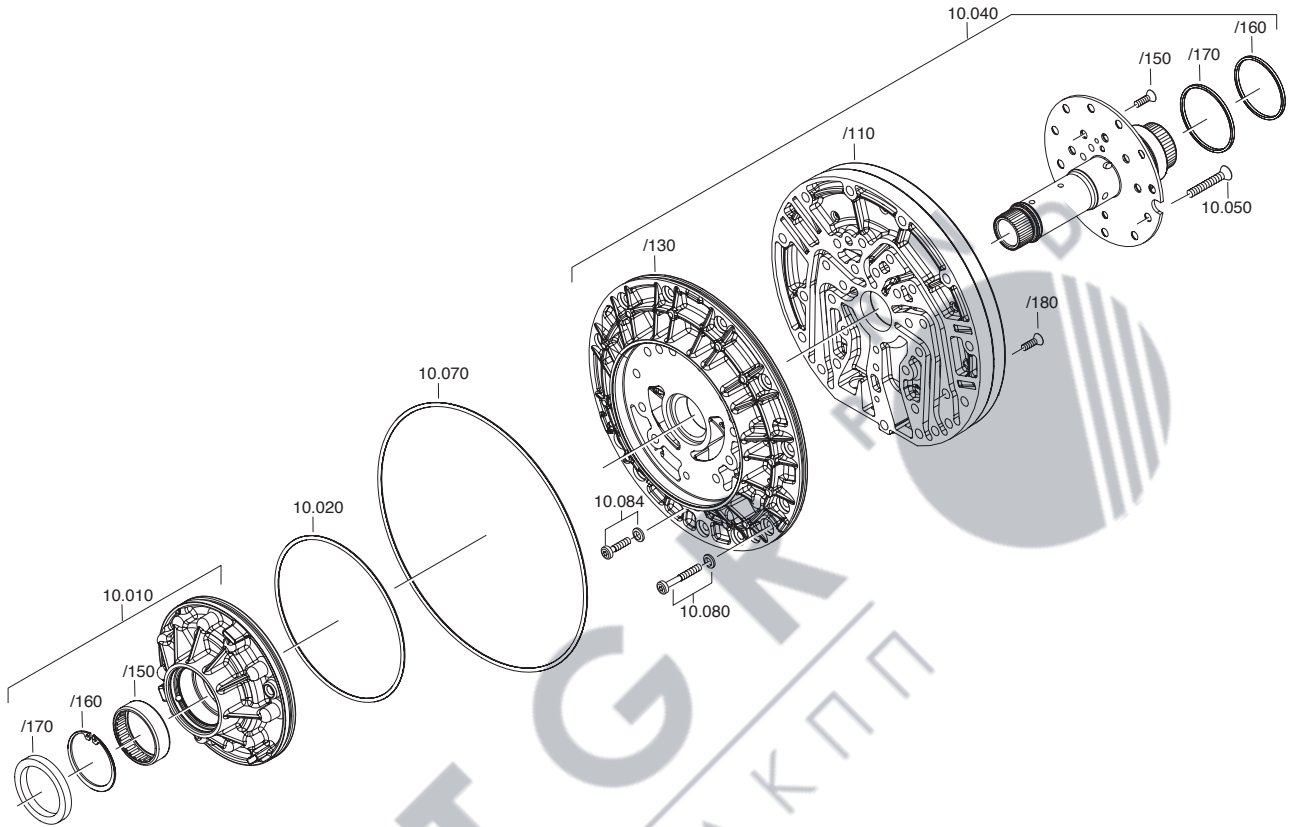

Re-attach all components to pump 10.010.  
Press in needle roller bearing 10.010/150 using assembly mandrel 5x46 002 558 (with ring) in the mandrel press and secure with snap ring 10.010/160.

Then fit shaft sealing ring 10.010/170 into the pump housing and press into the pump using assembly mandrel 5x46 002 558 (without ring).



Pull on new O-ring seal 10.020. Lubricate the pump wheel and internal ring gear lightly before assembly. Then assemble the pump in such a way that one marking is visible both on the pump wheel and the internal ring gear.

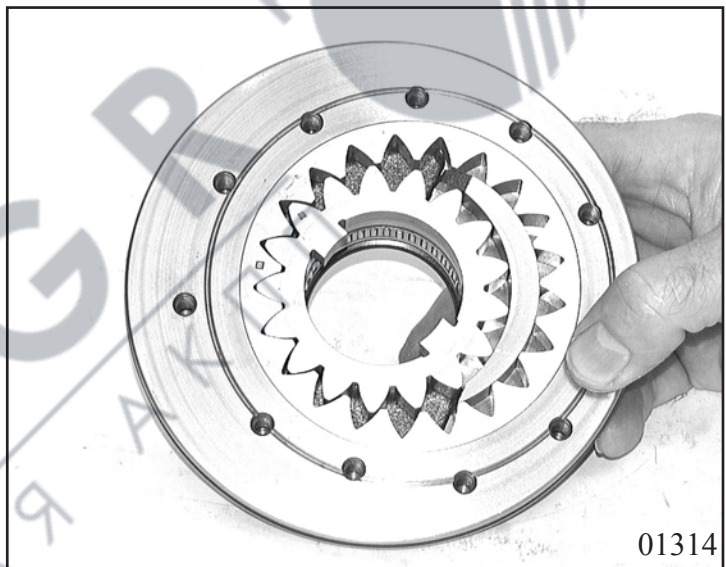

Pull 2 cylindrical rings 10.040/160 + /170 onto the stator shaft 10.140. So that the stator shaft can be mounted on the intermediate plate, these must be positioned towards each other. Follow the procedure stated on the next page.

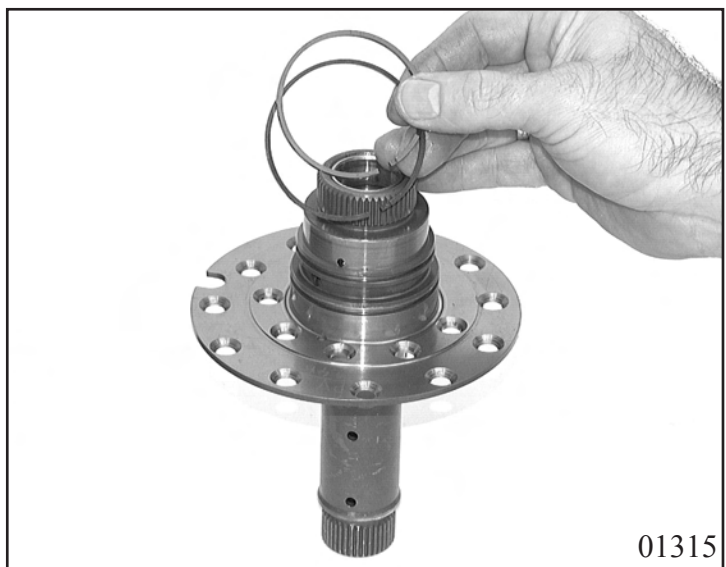





01316

Place intermediate plate 10.040/110 on centering plate 10.040/130 and hold it in position with 4 screws 10.040/180, but without tightening.

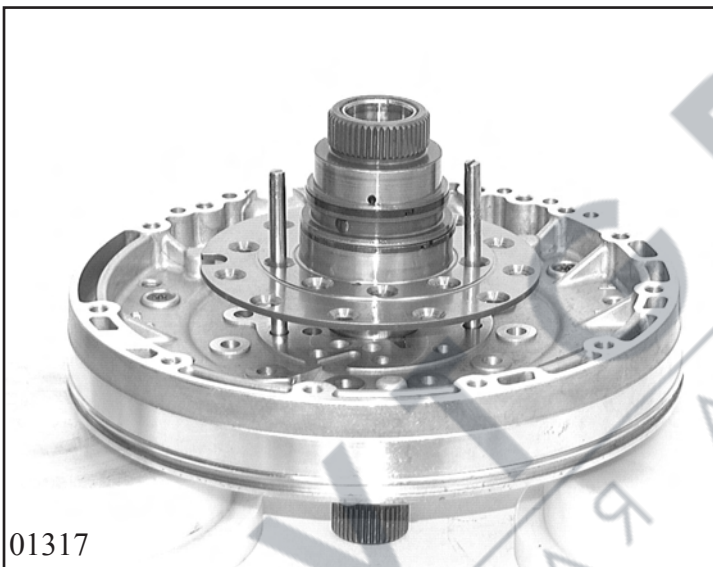

01317

Put the intermediate and centering plates on a supporting fixture and heat up with a hot-air blower to approx. 70 °C. Screw 2 locating bolts 5x46 001 007 into the centering plate. Insert the stator shaft over the locating pins and fasten first with countersunk screws 10.040/150. Remove the locating pins, insert the remaining two countersunk screws and tighten the 4 screws previously screwed in.

(For tightening torque, see Chapter 1.5)

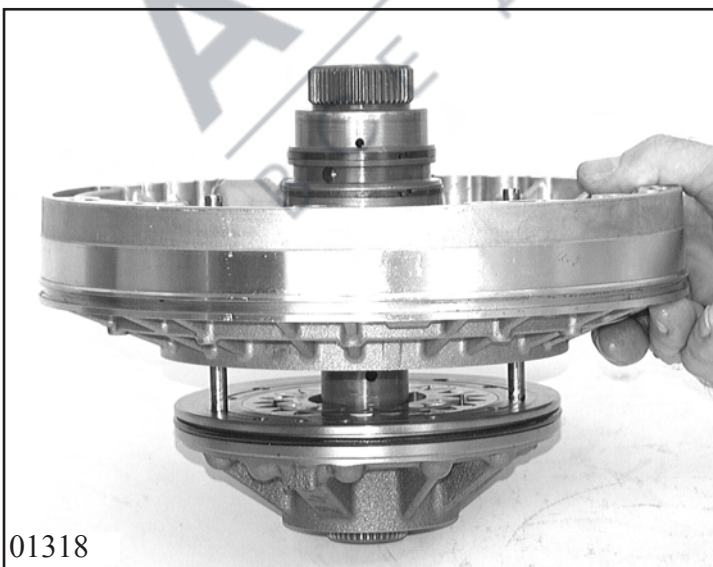

01318

Screw locating pins 5x46 001 007 into pump. Mount complete pump over stator shaft, remove locating pins and tighten down with 11 machine screws 10.050.

(For tightening torque, see Chapter 1.5)

**Note:**

Check pump with sleeve 5x46 000 306 for free running. Pump wheels must rotate easily when turned.

Pull new O-ring seal 10.070 onto centering plate.

Apply a small amount of Vaseline to the rectangular-section rings on the input shaft

Carefully place the complete oil supply unit in the transmission casing using lifting device 5x46 000 563, align and press in.

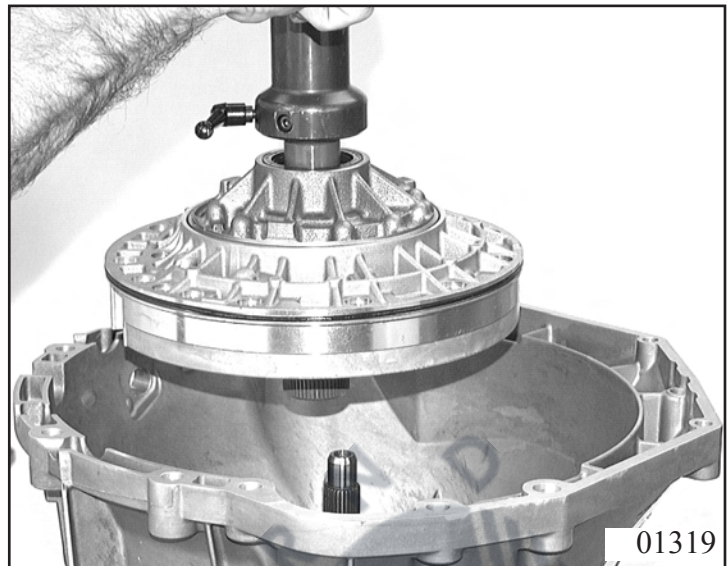

Tighten down the oil supply with 14 Torx screws and new Usit rings as follows:

- 1x 10.084 (see picture)  
20 mm long
- 13x 10.080 (remaining screws)  
50 mm long

(For tightening torque, see Chapter 1.5)

**Note:**

For adjusting work, see **Chapter 1.4.7**

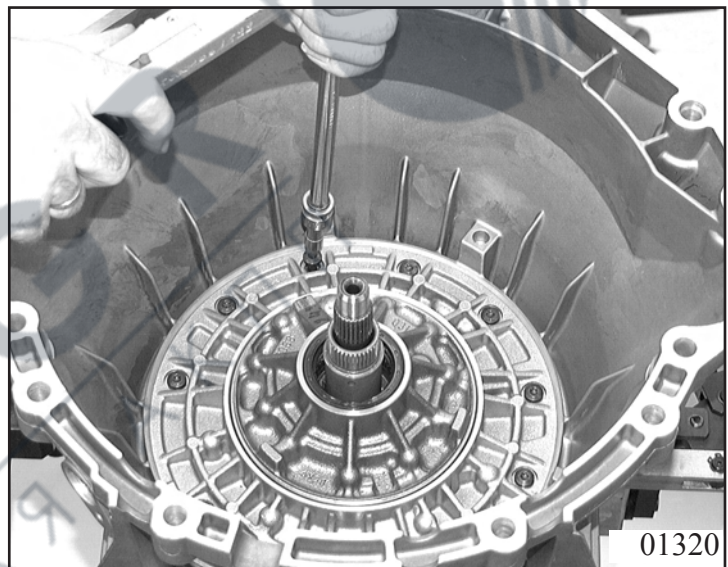

**3.7 Mechatronics, oil pan and converter**  
 (Complete mechatronics, see spare parts list, technical cover sheet, item YO2)

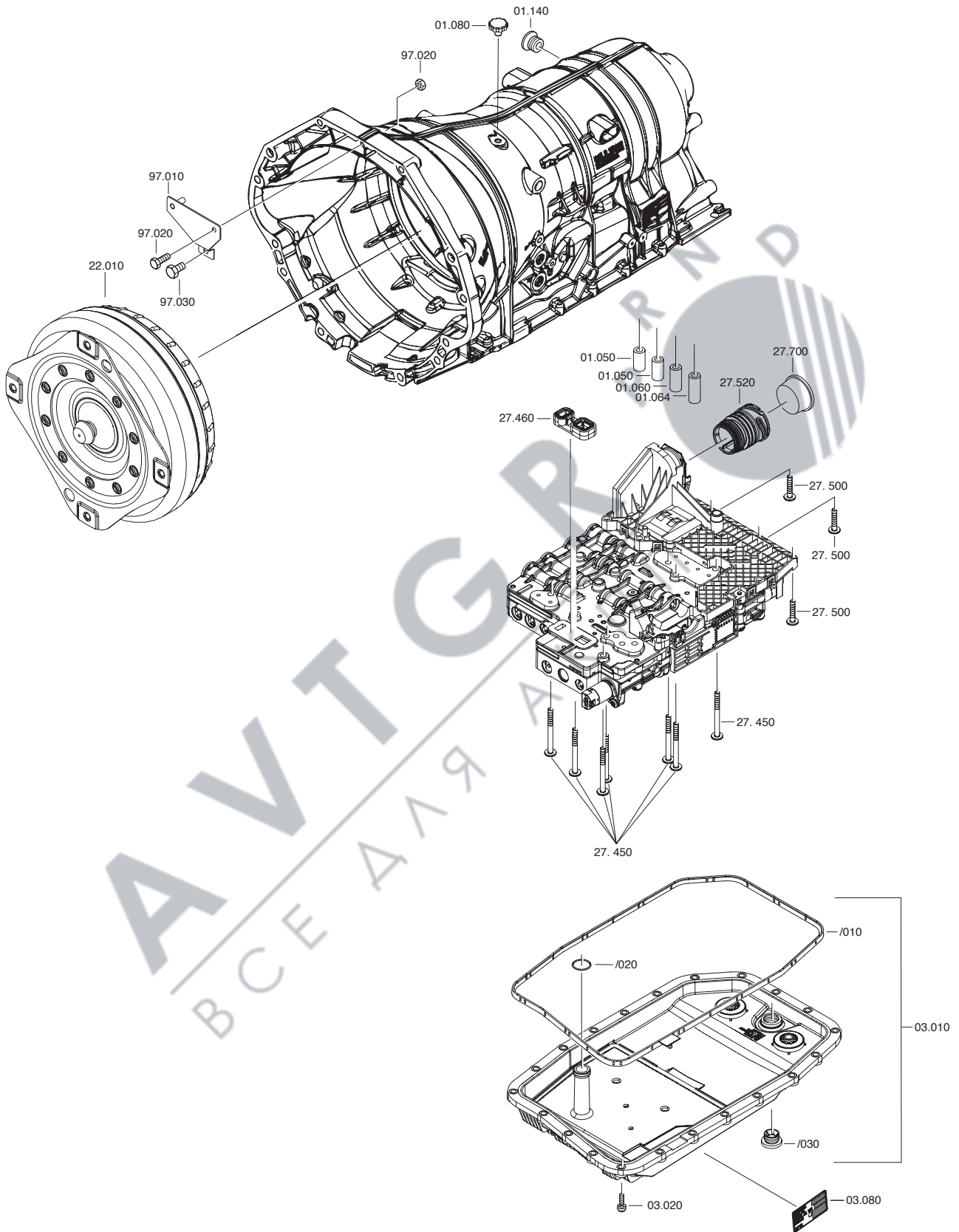

Turn the gearbox housing through 90°. Press 4 sealing sleeves (2x 01.050, 01.060, 01.064) between the transmission housing and CD cylinder by hand.

**Warning!**

Pay attention to the length of the sealing sleeves. They must all project by about the same length.  
Oil the sealing sleeves lightly.

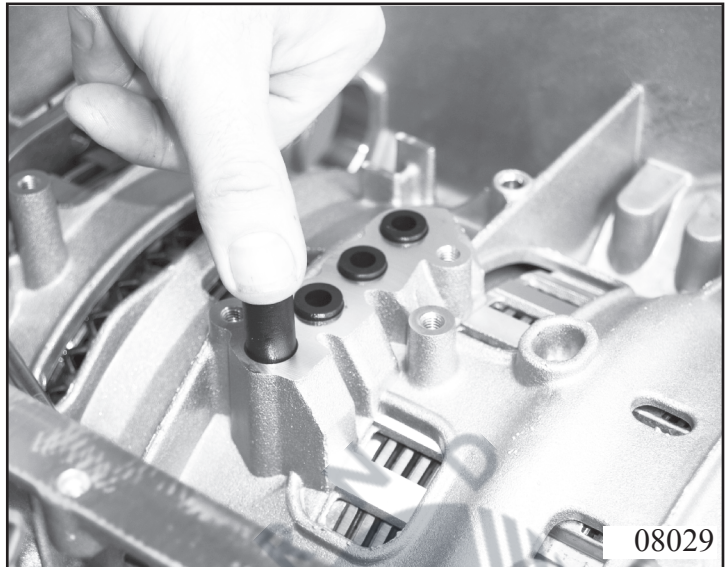

Insert adaptor 27.460 into the transmission casing.

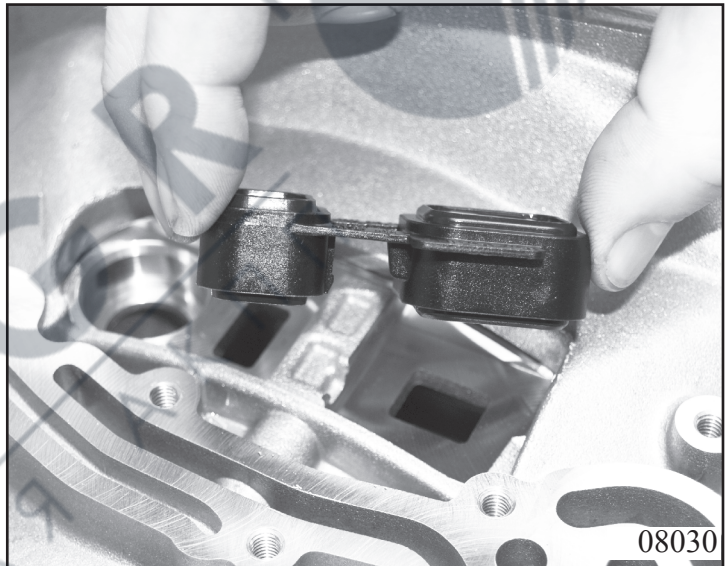

Check all clutches / brakes for proper function by supplying compressed air to the marked bores (see picture alongside)

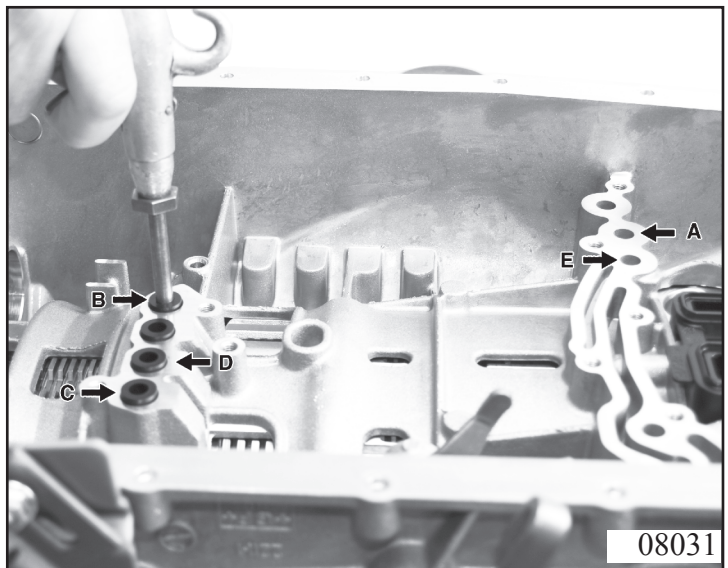

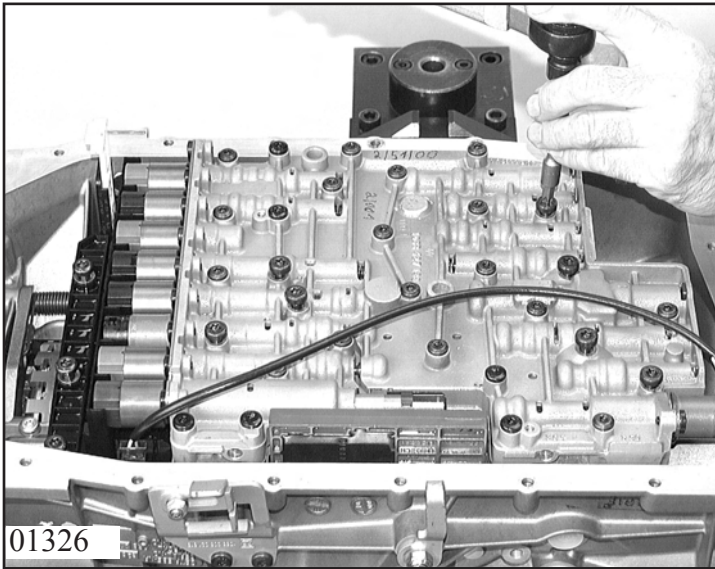

Attach parking or detent disk at groove in piston rod.

Place mechatronic and align mechatronics, press on by hand and fasten with 10 machine screws 27.450 and 3 machine screws 27.500.

(For tightening torque, see Chapter 1.5)

**Note:**

For screw specifications, see **Chapter 1.3.1**

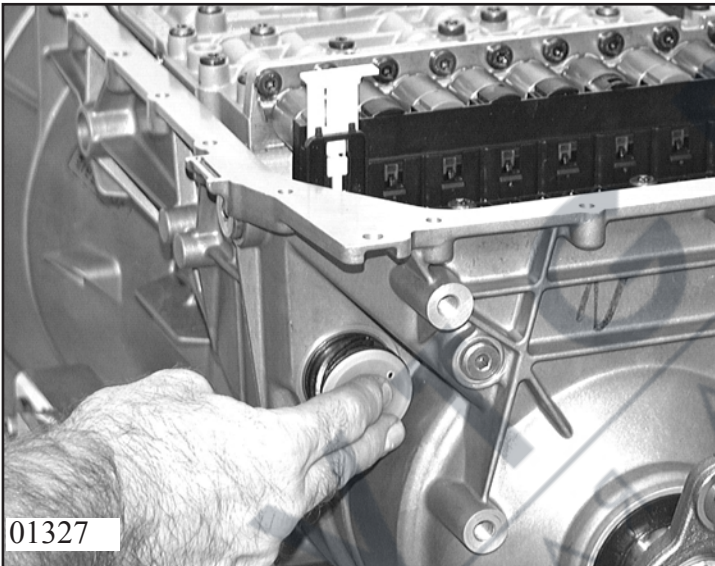

Press in new guide sleeve 27.520 with covering cap 27.700 and secure with retaining clip.

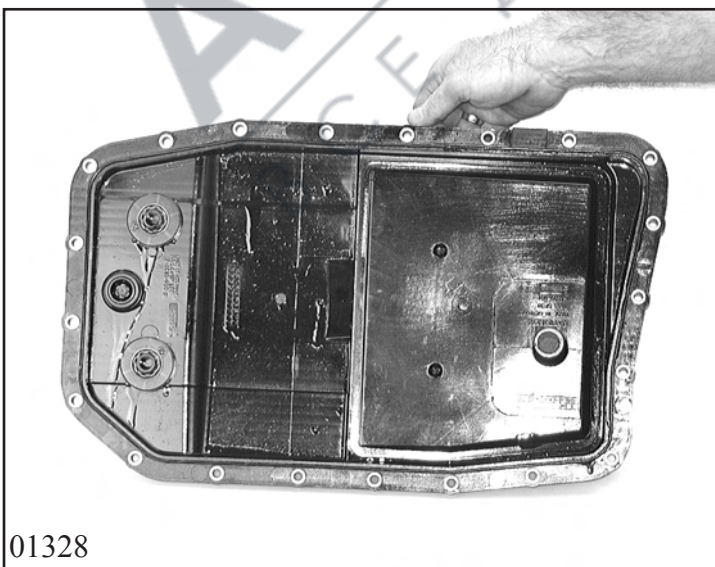

Pull new O-ring seal 03.010/020 onto stub pipe of oil filter 03.010. Press new seal 03.014/010 into oil pan.

Install oil pan 03.010 and fasten with 21 machine screws 03.020.

(For tightening torque, see Chapter 1.5)

**Warning!**

For BMW cars a label 03.150 (oil filling) must be attached to the oil pan.

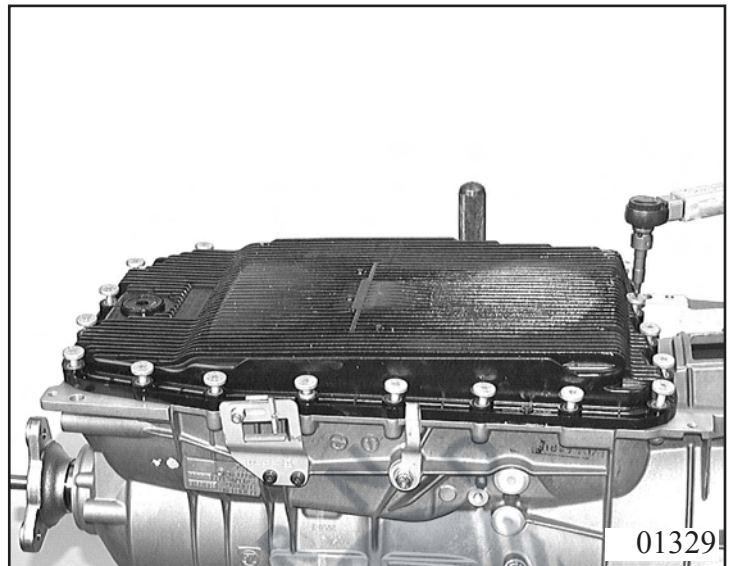

Insert new screw plugs 01.140 into transmission casing and 03.010/030 into oil pan.

(For tightening torque, see Chapter 1.5)

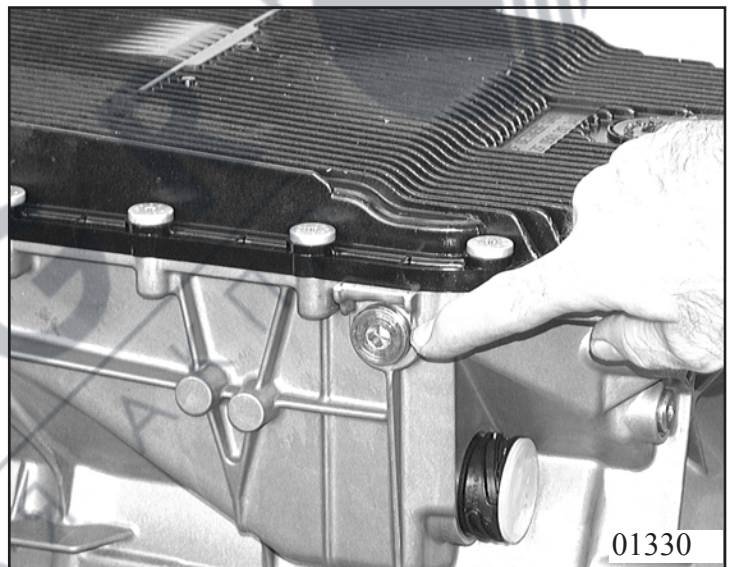

Screw in both converter handles 5x56 000 090 and carefully insert converter 22.010.

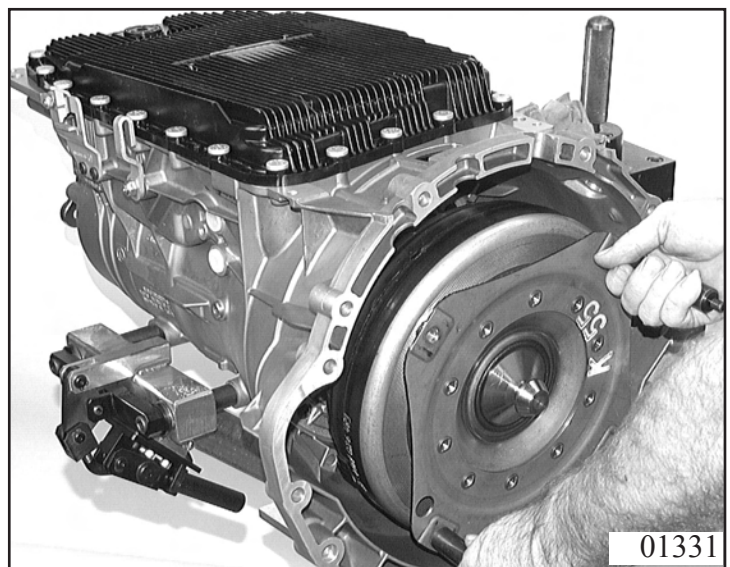

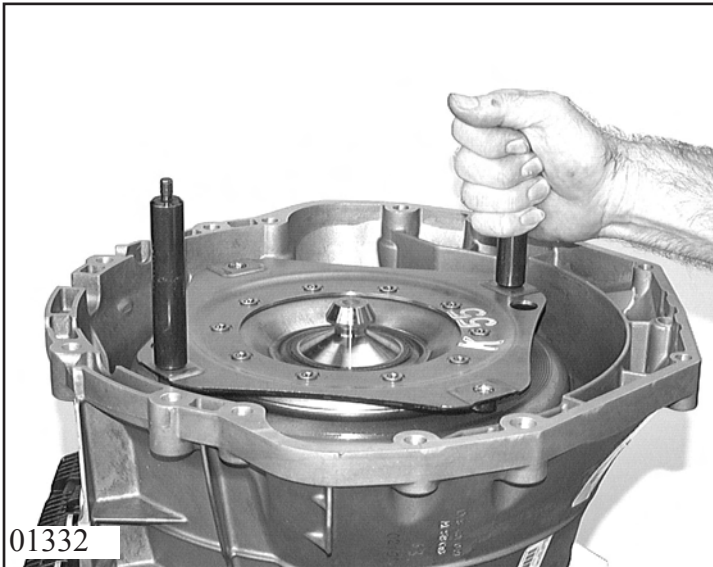

Turn transmission by 90° and move converter back and forward until the pump drive pins engage.

**Warning!**

When inserting, make sure that the drive pins are not damaged.

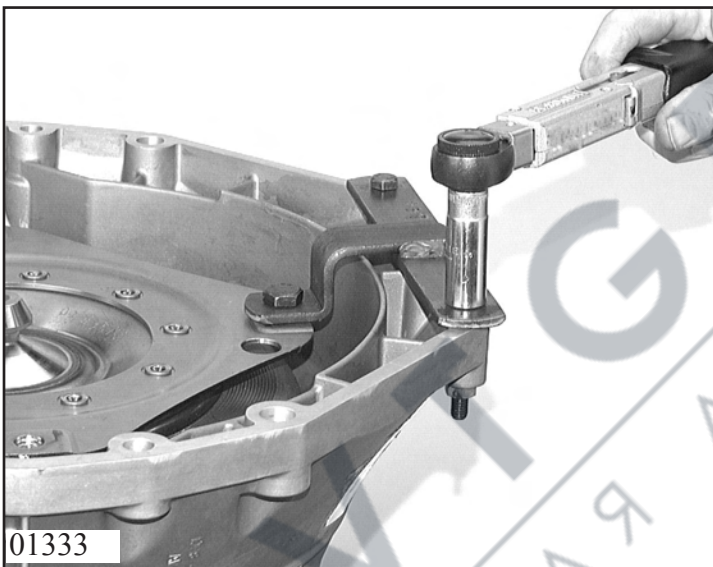

Remove converter handles.  
Screw on converter retaining bracket 97.010 with 2 screws (97.020 and 97.030).

The thread eventually has to be re-treated due to glue residues.

(For tightening torque, see Chapter 1.5)

**Warning!**

Converter fastening screw 97.030 must not be too long - recommended length 16 mm - otherwise there is a risk of damaging the converter and thus causing the lock-up clutch to malfunction.

References to possible *mechatronics functional tests* can be found in the relevant trouble-shooting program.

Attach breather cover 01.080 to breather.

Attach the remaining transport plug:

-1 plug at selector shaft 06.050

**Note!**

Right-hand-drive cars have 2 plugs at the selector shaft.

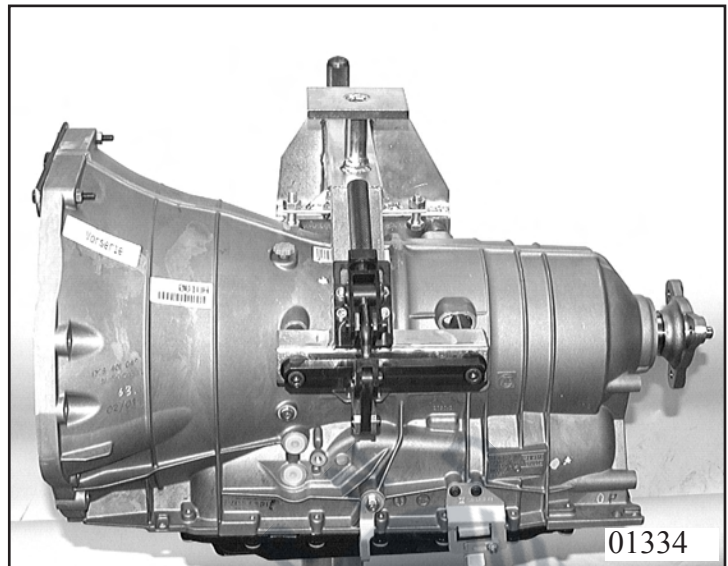

AVTGR  
ВСЕ ДЛЯ АКПП