

Repair Instructions

8HP75X

Repair stage 3

Automatic transmission

Passenger Cars

AVTIGR
ВСЕ ДЛЯ АКПП





Copyright © ZF Friedrichshafen AG

This document is protected by copyright.

Complete or partial reproduction or distribution of this document is not permitted without the approval of ZF Friedrichshafen AG.

Infringements lead to civil and criminal prosecution.

This document is a translation of the German original.

1	Preface	6
1.1	Specialized staff	7
1.2	Technical information	7
2	Safety Instructions	8
2.1	Signal words and symbols	9
2.2	General safety instructions	11
3	Repair Instructions	13
3.1	Cleanliness instructions	13
3.2	Dismantling	13
3.3	Cleaning parts	13
3.4	Reusing parts	14
3.4.1	O-rings, shaft sealing rings, rectangular rings, seals	14
3.4.2	Screws, nuts	14
3.4.3	Snap rings and securing rings	14
3.4.4	Bearings, adjustment plates	14
3.4.5	Gearings	15
3.4.6	Multidisks	15
3.4.7	Mechatronic/Control unit	15
4	Description	16
4.1	Product information	16
4.1.1	Transmission illustration	16
4.1.2	Oil circuit plan DIN scheme E26/28	17
5	Settings	18
6	Tightening Torques	19
7	Workshop Equipment	20
7.1	Special tools	20
8	Preparatory Activities	29
8.1	Loading the transmission	29
8.2	Draining transmission oil	29
9	Dismantling	30
9.1	Removing torque converter	30
9.2	Removing output	31
9.3	Removing oil pan	32
9.4	Removing Mechatronic and hydraulic impulse oil storage	33
9.4.1	Removing hydraulic impulse oil storage	33
9.4.2	Removing Mechatronic	34
9.5	Removing parking lock	37
9.6	Removing oil supply	40

Table of Contents

9.7	Removing tower	42
9.7.1	Lifting out tower	42
9.7.2	Dismantling tower	43
9.7.3	Dismantling planetary gearset 1	44
9.7.4	Dismantling planetary gearset 2	46
9.7.5	Removing ring gear 2	48
9.7.6	Removing pot 3 from pot 1	49
9.7.7	Removing planetary gearset 3	50
9.7.8	Removing clutch E/C	51
9.7.9	Removing ring gear 4	53
9.8	Removing output	53
9.9	Dismantling oil supply	56
9.10	Dismantling pump	59
9.11	Dismantling clutch E	61
9.12	Dismantling clutch C	63
9.13	Dismantling clutch D	65
10	Testing, Measuring, Adjusting	68
10.1	Setting running clearance of clutch D	68
10.2	Setting running clearance of clutch C	72
10.3	Setting running clearance of clutch E	76
10.4	Setting running clearance of brake A	79
10.5	Setting running clearance of brake B	83
10.6	Setting backlash	86
10.7	Directives on screw connections	88
10.7.1	Oil supply	88
10.7.2	Mechatronic and hydraulic impulse oil storage	89
10.7.3	Oil pan	90
10.7.4	Intermediate plate	91
10.7.5	Guiding plate	92
11	Assembly	93
11.1	Fitting output	93
11.2	Assembling parking lock	95
11.3	Assembling clutches	99
11.3.1	Assembling clutch D	99
11.3.2	Assembling clutch C	103
11.3.3	Assembling clutch E	106
11.4	Assembling oil supply	109
11.4.1	Installing pump	109
11.4.2	Assembling oil supply	111
11.4.3	Assembling brake A	114
11.4.4	Assembling brake B	117
11.5	Completing tower	119
11.5.1	Installing ring gear	119
11.5.2	Installing clutch C/E	120

11.5.3	Installing planetary gearset 3	121
11.5.4	Installing pot 3/pot 1	123
11.5.5	Installing ring gear/planetary gearset 2	124
11.5.6	Installing planetary gearset 2	125
11.5.7	Installing planetary gearset 1	128
11.6	Installing tower and oil supply	130
11.6.1	Installing tower	130
11.6.2	Installing oil supply	133
11.7	Installing Mechatronic and hydraulic impulse oil storage	135
11.7.1	Installing Mechatronic	135
11.7.2	Installing hydraulic impulse oil storage	137
11.8	Fitting oil pan	139
11.9	Fitting output	141
11.10	Installing torque converter	143
11.11	Screwing in screw plugs	145
12	Annex	146
12.1	List of abbreviations	146
12.2	Overview of revisions	146

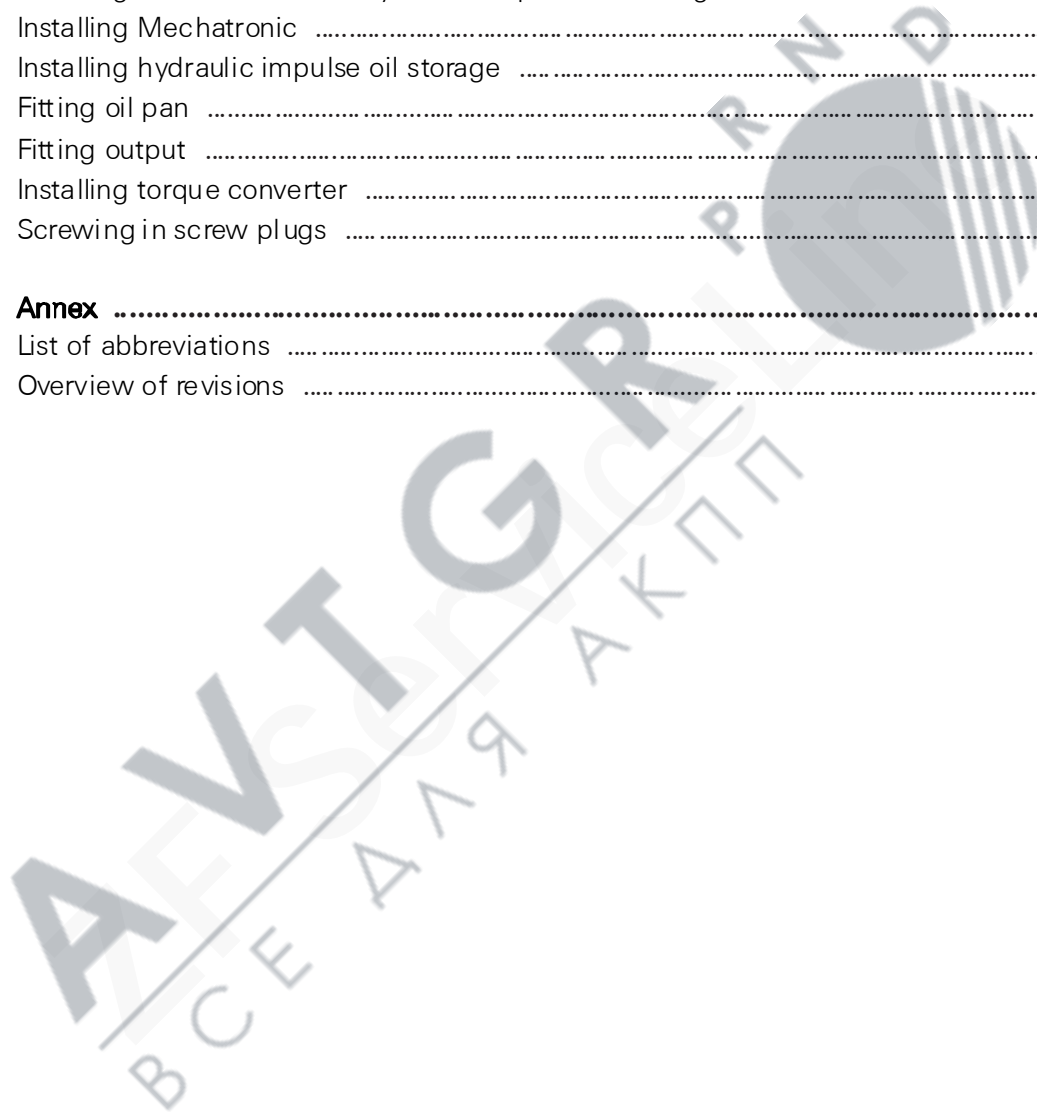

1 Preface

This documentation was developed for specialized staff trained in the operation of ZF products by ZF Friedrichshafen AG (hereinafter referred to as ZF).

The work may only be performed by authorized, trained and instructed staff. The user company is responsible for training the authorized, specialized staff and providing required documents.

The technical information depends on the parts list [BoM]. Due to technical further developments of the ZF product, deviating work steps and Technical Data might be necessary during repair. Therefore, information on technical requirements must be obtained before carrying out the repair. Technical information is available from the ZF-ServiceLine or the ZF Service Data Management

The figures illustrate the workflow and may deviate from the ZF product. The figures are not binding.

ZF Friedrichshafen AG



1.1 Specialized staff

The work may only be performed by trained and instructed specialized staff. As a result of specialized training and practical experience, the specialized staff must be capable of detecting risks and avoiding possible dangers which may be caused by the operation, maintenance and repair of the product.

To avoid injury to personnel and damage to the product, all safety regulations and legal requirements must be adhered to.

Country-specific safety, accident prevention and environmental regulations apply irrespective of the instructions provided in this document.

Wear safety-relevant workwear for all work.

1.2 Technical information

The transmission is filled with a lifetime oil.

Depending on the driving mode, changing the transmission oil is required after a mileage of 100,000 km or after 8 years.

The transmission shall only be delivered with the oil quantity and oil grade specified in the corresponding parts list (refer to Service Data Management).

2 Safety Instructions

WARNING

Risk of injury due to falling parts.

Death or serious injury possible.

- ⇒ Secure parts against falling down.
- ⇒ Do not stand beneath a suspended load.
- ⇒ Do not work on a suspended load.

WARNING

Risk of injury due to rotating parts.

Death or serious injury possible.

- ⇒ Wear tight-fitting clothing.
- ⇒ Wear a hair net.
- ⇒ Wear protective clothing.
- ⇒ Wear safety boots.

WARNING

Risk of injury due to caustic liquid or irritant gas.

Acid burn of skin possible.

Irritation of the airways and the lungs possible.

- ⇒ Wear protective gloves.
- ⇒ Wear protective goggles.
- ⇒ Wear a respirator.

CAUTION

Risk of injury due to sharp edges.

Slight to moderate injury possible.

- ⇒ Attach safety device.

CAUTION

Risk of injury due to machine-cutting works.

Slight to moderate injury possible.

- ⇒ Wear protective goggles.

NOTICE**Property damage due to electrostatic discharge (ESD) possible.**

- ⇒ Observe ESD protection.
- ⇒ Do not touch contacts.
- ⇒ Wear conductive workwear.
- ⇒ Use ESD transport protection.
- ⇒ Use ESD protective packaging.

NOTICE**Environmental risk as a result of oil getting into the soil, groundwater and sewage system.**

- ⇒ Collect oil in a suitably large container.
- ⇒ Dispose of used operating supplies, cleaning agents and filters in accordance with local applicable regulations.
- ⇒ Request the material safety data sheets for the respective products from the responsible environmental protection agency and observe them.

2.1 Signal words and symbols

This document contains particularly highlighted safety instructions which are marked with one of the following signal words depending on the severity of the danger.

 DANGER**DANGER**

The signal word **DANGER** indicates a dangerous situation that, if not prevented, will lead to a severe injury or death.

- ⇒ Information as to how the danger can be prevented.

 WARNING**WARNING**

The signal word **WARNING** indicates a dangerous situation that, if not prevented, can lead to a severe injury or death.

- ⇒ Information as to how the danger can be prevented.

 CAUTION**CAUTION**

The signal word **CAUTION** indicates a dangerous situation that, if not prevented, can lead to a slight or moderate injury.

- ⇒ Information as to how the danger can be prevented.

NOTICE

The signal word NOTICE indicates a situation that, if not prevented, can lead to property damage.

⇒ Information as to how the property damage can be prevented.

The following symbols are additionally used:



This symbol refers to additional, safety-relevant information.



This symbol indicates information concerning special workflows, methods, application of aids, etc.



2.2 General safety instructions

Read all safety instructions and information. Failure to comply with safety instructions and information may lead to property damage, serious injuries or death.

Intended use

The ZF product is exclusively intended for the application as defined in the contract and as agreed on the time of delivery. Any other or extended form of use does not comply with this definition of intended use. The intended use includes compliance with this documentation and other applicable documents, in order to avoid malfunctions and damage in operation.

The ZF product is designed and produced in line with state-of-the-art technology. The ZF product in its delivery status is safe to operate. However, the ZF product may pose dangers if improperly used by unauthorized, untrained and uninstructed staff or if not used according to its intended use.

Figures might deviate from the ZF product and are not drawn to scale. No conclusions can be drawn with regard to size and weight.

Installation, commissioning, maintenance and repair

Perform assembly, commissioning, maintenance and repair work exclusively according to this documentation and other applicable documents.

Observe the following points:

- Employ authorized, trained and instructed staff.
- Observe technical provisions.
- Only use genuine ZF spare parts.
- Only use genuine ZF accessories.
- Only use genuine ZF special tools.
- Unauthorized changes and modifications lead to the expiry of the operator's license, warranty or guarantee.

In case of damage, contact ZF and have the following information on the product ready:

- Type
- Parts list [BoM] number
- Serial number
- Operating hours
- Description of damage

Observe safety instructions, valid safety regulations and legal conditions to prevent malfunctions and damage.

The country-specific safety regulations, accident prevention regulations and environmental protection provisions apply additionally.

Wear safety-relevant workwear for all work. Depending on the work, also wear personal protective equipment.

After completing the work, check correct function and functional security.

Handling of ZF product

Unauthorized changes and modifications might impair functional security. Changes, modifications and applications are only permissible upon written approval by ZF Friedrichshafen AG.

Observe the following when working on the ZF product:

- Secure workspace.
- Only carry out work at the unit when in a voltage-free state.
- Protect unit against being started accidentally. Attach instruction plate where it is clearly visible.
- Perform work when engine is switched off.
- Protect engine against being started accidentally. Attach instruction plate where it is clearly visible.
- Do not stand beneath a suspended load.
- Do not work on a suspended load.
- Only use permitted means of transport and lifting devices with sufficient load-bearing capacity.
- Close open tubings and hoses and avoid damage.
- Observe tightening torques.
- Protect cables against mechanical damage.

Noise

Noise might cause irreversible damage to hearing.

The perception of acoustic signals, warning calls or sounds warning of impending danger is impaired by noise.

Observe the following when working on the ZF product:

- Avoid noise.
- Wear ear protection.

Operating supplies and aids

Operating supplies and aids might cause permanent damage to health and environmental damage.

Observe the following when selecting operating supplies and aids:

- Health risks
- Environmental compatibility
- Material safety data sheets

Observe the following when handling operating supplies and aids:

- Store operating supplies and aids in suitable and correctly labeled containers.
- Seek medical help in case of injuries due to hot, cold or caustic operating supplies or aids.

Observe the following to protect the environment:

- Collect leaking operating supplies and aids in sufficiently large containers.
- Observe disposal regulations.
- Observe material safety data sheets.

3 Repair Instructions

3.1 Cleanliness instructions

Observe provisions for the repair process and the workshop equipment:

- Use separate cleaning processes for outer transmission parts and for parts of the hydraulic system.
- Parts made of Fe metals must be demagnetized.
- Only use cleaning cloths which do not fray.
- Only apply lubricant using a high-quality and wear-resistant brush whose bristles do not fall out.
- Cover operating supplies and auxiliary materials before and after use.
- Store and transport ready-to-install components and assembly groups when properly covered.

Observe specifications for the workshop equipment:

- Design support surfaces for material and tools in such a way that no deposits may occur (e.g. grate, perforated sheet metal).
- Work surfaces must be abrasion-proof and easy to clean.
- Workshop equipment (cabins, racks, workbenches, etc.) and its respective arrangement in the room should always be designed in such a way that proper cleaning of the room and floor is possible.
- It must be possible to clean the floor (e.g. through abrasion-proof sealing).

3.2 Dismantling

- To avoid mixing up parts, uniquely assign parts to the disassembled ZF product. In particular, this applies to gear parts, reusable spacer washers or shims, electronic components, etc.
- Assemblies which must not be disassembled or are only available as spare parts assembly are described accordingly. Please observe the spare parts catalog for the ZF product.
- Inspect the parts during disassembly in order to find a potential cause of damage.

3.3 Cleaning parts

Thoroughly clean the product with an appropriate cleaning agent prior to repair or assembly works. Thoroughly clean the angles and recesses of housing and cover.

- Remove all reusable components after disassembly.
- Remove sealing compound residue on sealing faces or retaining agent residue, e.g. in tapped holes.
- Clean contact surfaces and check for damage.
- Wash out blind holes and blind hole threads and remove contamination.
- Lubricating bores, oil bores, oil ducts, bores for oil press fits and lubricating grooves must be free from dirt, preservative and foreign matter. If possible, blow through with compressed air. Check for perfect passage.
- Hose assemblies, oil tubes and joining elements must be free from dirt, oil and chafe marks. Thoroughly clean dirty or oily components; if necessary, blow through with compressed air. Replace damaged parts.
- Clean cavities and reliefs.
- Thoroughly remove burrs or other similar rough surfaces using a grindstone. Replace the component in case of more severe damage.
- Thoroughly remove preservative from new parts (e.g. on bearings).

3.4 Reusing parts

Authorized, specialized staff assess whether parts can be reused. The list of replacement parts can be downloaded from the ServiceLine.

- Replace parts if they are damaged.
- Replace parts if they are worn, e.g., rolling bearings, multidisks, thrust washers, etc.
- Replace parts if they have been overheated during operation or during disassembly.

Renew every time:

- Bolts with reduced shank, aluminum screws, seals, etc., and parts that are intended for single use only
- Sealing rings
- Shaft sealing rings
- Rectangular rings
- Snap and securing rings

Replace parts with genuine ZF parts. Please observe the spare parts catalog for the ZF product.

3.4.1 O-rings, shaft sealing rings, rectangular rings, seals

- After having removed the seals, check the contact surfaces at the transmission housing for damage.
- For installation, coat O-rings, rectangular rings and other sealing rings with white petroleum jelly and shaft sealing rings with oil.
- Fit rectangular rings with suitable assembly sleeve.
- In case of damage to the vulcanized sealing rings, replace the complete unit.
- Replace vulcanized components after a certain mileage. The information is available for download from the ServiceLine.

3.4.2 Screws, nuts

- Unfasten screws in reverse tightening sequence.
- Tighten screws according to specified tightening sequence.
- Unfasten and tighten screws without tightening sequence crosswise and in steps.

3.4.3 Snap rings and securing rings

- Snap and securing rings must fit tightly at the groove base.

3.4.4 Bearings, adjustment plates

- Only install bearings when oiled.
- In case of damage to pressed-in needle roller bearings or drawn cup needle roller bearings, replace the complete unit. Exceptions are possible.
- Measure adjustment plates at several spots using a micrometer.

3.4.5 Gearings

- Check gearings for damage.
- For some gear drives, the gears are paired. In this case, replace all meshing parts in combination.

3.4.6 Multidisks

- Check lined clutch disks and steel multidisks for damage or overheating and replace them, if necessary.

3.4.7 Mechatronic/Control unit

- The Mechatronic or the control unit are considered as a complete unit in these instructions.
- In case of damage, replace Mechatronic or control unit completely.



4 Description

4.1 Product information

4.1.1 Transmission illustration

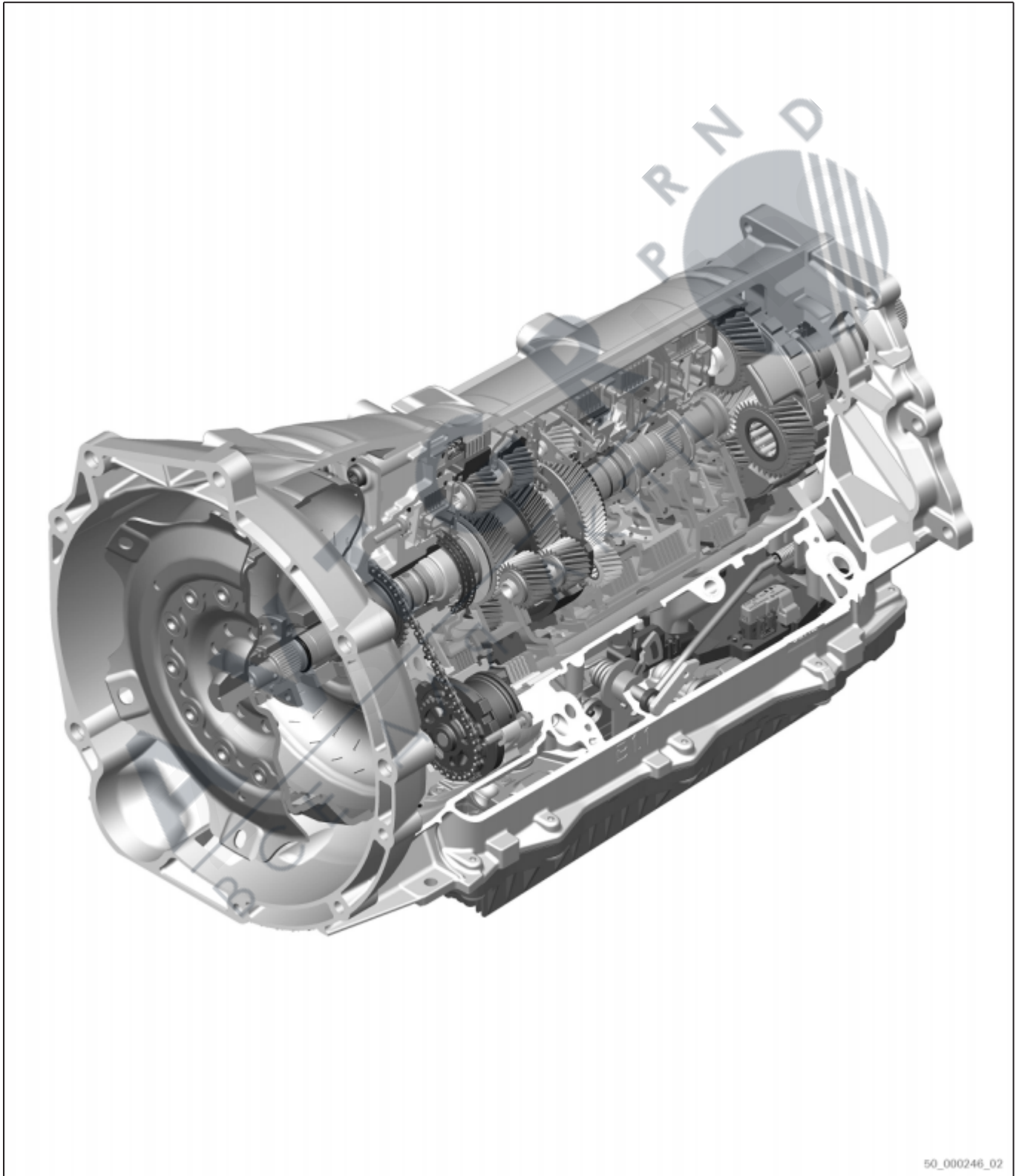

Fig. 1 Transmission illustration 8HP75X

4.1.2 Oil circuit plan DIN scheme E26/28

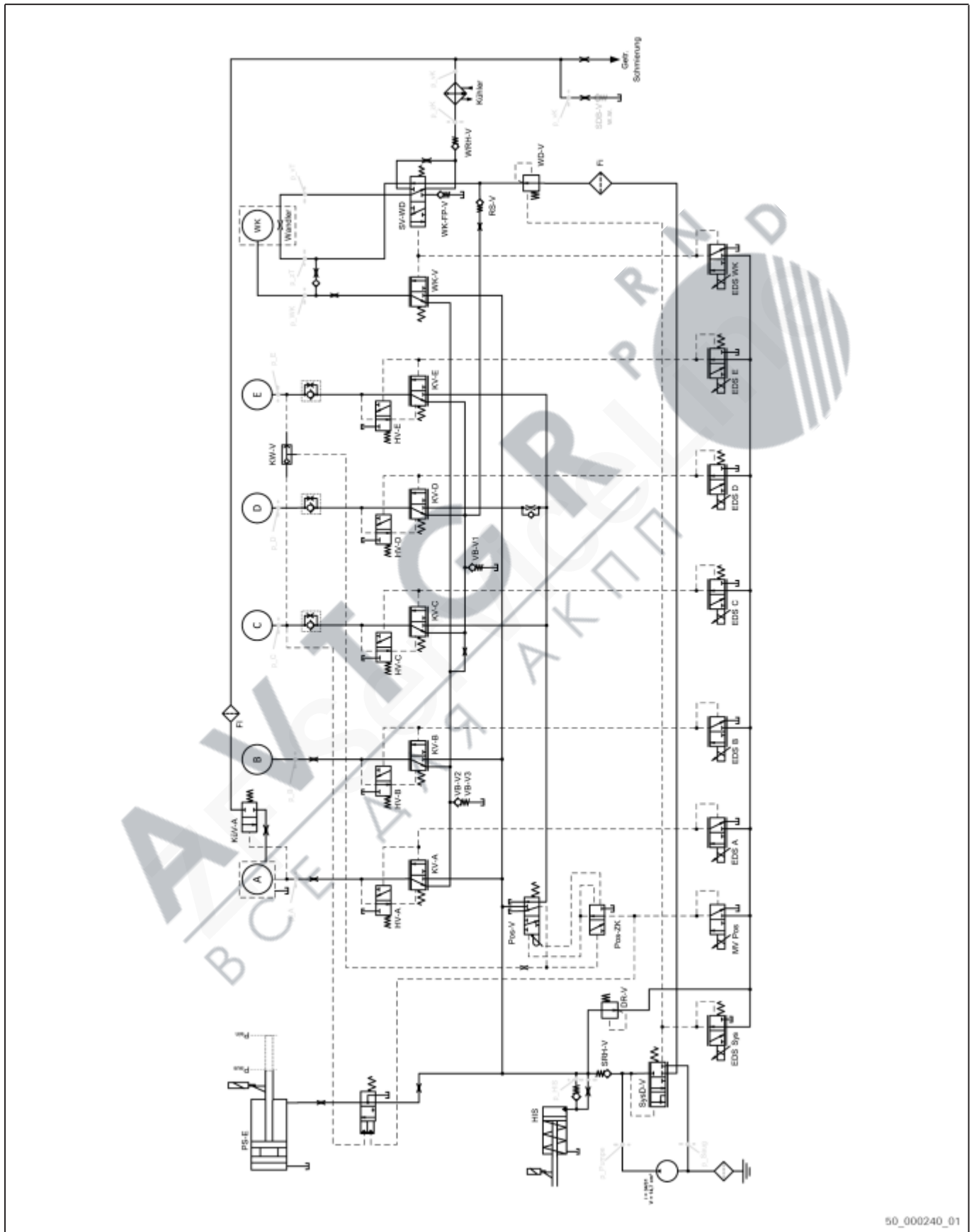

Fig. 2 Oil circuit plan DIN scheme E26/28

5 Settings

Designation	Dimensions	Measuring instrument	Comment Chapter/Section
Running clearance tolerance of clutch D	1.33 mm - 1.62 mm	Dial gage	For version with 4 multidisks, set running clearance with snap ring (73.180) • Setting running clearance of clutch D, page 68
Running clearance tolerance of clutch C	1.90 mm - 2.40 mm	Dial gage and height measuring device	For version with 6 multidisks, set running clearance with end disk (75.110) • Setting running clearance of clutch C, page 72
Running clearance tolerance of clutch E	1.56 mm - 2.05 mm	Dial gage and height measuring device	For version with 5 multidisks, set running clearance with end disk (71.060) • Setting running clearance of clutch E, page 76
Running clearance tolerance of brake A with/without separation	1.66 mm - 1.95 mm	Dial gage	For version with 4 multidisks, set running clearance with snap ring (70.160) • Setting running clearance of brake A, page 79
Running clearance tolerance of brake B with/without separation	1.71 mm - 2.12 mm	Dial gage	For version with 5 multidisks, set running clearance with end disk (72.040) • Setting running clearance of brake B, page 83
Backlash tolerance	0.11 mm - 0.32 mm	Dial gage	Set backlash with adjustment plate • Setting backlash, page 86

6 Tightening Torques

Designation	Tightening torque	Measuring instrument	Comment Chapter/Section
(24.020) Screw plug of parking lock bolt	35 Nm (± 3.5 Nm)	Torque wrench	• Assembling parking lock, page 95
(24.120) M6x20 hexalobular driving screw	10 Nm (± 1.0 Nm)	Torque wrench	• Assembling parking lock, page 95
Centering plate with downholder	11 Nm (± 1.1 Nm)	Clamping device	• Assembling oil supply, page 111
(10.110) M6x24 aluminum torx screw	4.0 Nm (± 0.5 Nm) and 90° ($\pm 5^\circ$)	Torque wrench	• Assembling oil supply, page 111
(10.230) M8x70 torx screw	10 Nm (± 1.0 Nm) and 90° ($\pm 5^\circ$)	Torque wrench	• Installing oil supply, page 133
(28.450) M6x59 torx screw	8 Nm (± 0.8 Nm)	Torque wrench	• Installing Mechatronic, page 135 • Installing hydraulic impulse oil storage, page 137
(28.570) M6x20 torx screw	8 Nm (± 0.8 Nm)	Torque wrench	• Installing Mechatronic, page 135 • Installing hydraulic impulse oil storage, page 137
(28.580) M6x20 torx screw	8 Nm (± 0.8 Nm)	Torque wrench	• Installing Mechatronic, page 135
(03.030) M6x28.5 torx screw	10 Nm (± 1.0 Nm)	Torque wrench	• Fitting oil pan, page 139
(97.030) M10x16 hexagon screw	4.5 Nm (± 0.45 Nm)	Torque wrench	• Installing torque converter, page 143
(97.020) M10x55 bolt + nut	4.5 Nm (± 0.45 Nm)	Torque wrench	• Installing torque converter, page 143
(01.100) M10x1 PZT screw plug	12 Nm (± 1.2 Nm)	Torque wrench	• Screwing in screw plugs, page 145
(01.120) Screw plug for oil fill	35 Nm (± 3.5 Nm)	Torque wrench	• Screwing in screw plugs, page 145

7 Workshop Equipment

7.1 Special tools

The required quantity is listed. Please inquire as to packaging unit before ordering.

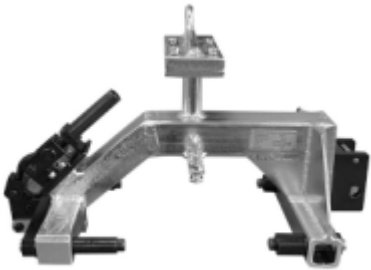



Figure	Order no. Designation Chapter/Section	Qty.	Comment
 <p>50_000262_01</p>	<p>5T66.000.286</p> <p>Assembly bracket</p> <ul style="list-style-type: none"> • Loading the transmission, page 29 • Fitting output, page 93 	1	
 <p>50_000291_01</p>	<p>5X46.002.807</p> <p>Lifting gear</p> <ul style="list-style-type: none"> • Removing torque converter, page 30 • Installing torque converter, page 143 	1	5W46.000.003 is required
 <p>50_000254_01</p>	<p>AA00.648.882</p> <p>Disassembly device</p> <ul style="list-style-type: none"> • Removing output, page 31 	1	for output shaft sealing ring
 <p>50_000256_01</p>	<p>AA00.589.201</p> <p>Assembly pliers</p> <ul style="list-style-type: none"> • Removing output, page 31 • Dismantling planetary gearset 2, page 46 	1	for output snap ring

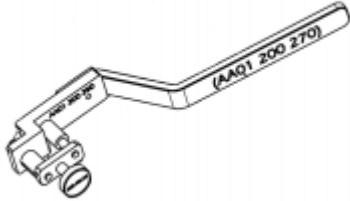



Figure	Order no. Designation Chapter/Section	Qty.	Comment
 <p>50_100081_01</p>	AA01.200.270 Holding device <ul style="list-style-type: none"> • Removing Mechatronic, page 34 • Removing parking lock, page 37 	1	for parking disk
 <p>50_000255_01</p>	AA00.548.098 Disassembly device <ul style="list-style-type: none"> • Removing Mechatronic, page 34 	1	for Mechatronic guiding sleeve
 <p>50_000203_01</p>	AA00.549.802 Disassembly device <ul style="list-style-type: none"> • Removing oil supply, page 40 • Installing oil supply, page 133 	1	Also use crank AA00.359.399
 <p>50_000260_01</p>	5X46.003.957 Tower lifting device <ul style="list-style-type: none"> • Lifting out tower, page 42 • Installing tower, page 130 	1	5W46.000.003 is required
 <p>50_000257_01</p>	5X46.004.264 Assembly fixture <ul style="list-style-type: none"> • Dismantling tower, page 43 • Removing pot 3 from pot 1, page 49 • Dismantling clutch D, page 65 • Assembling clutch D, page 99 • Installing clutch C/E, page 120 • Installing pot 3/pot 1, page 123 	1	for tower





Figure	Order no. Designation Chapter/Section	Qty.	Comment
 <p>50_000204_01</p>	<p>AA00.555.684</p> <p>Support ring</p> <ul style="list-style-type: none"> • Dismantling tower, page 43 	1	for pot 1
 <p>50_000258_01</p>	<p>AA00.686.190</p> <p>Supporting plate</p> <ul style="list-style-type: none"> • Dismantling planetary gearset 2, page 46 • Installing planetary gearset 2, page 125 	1	for input shaft
 <p>50_000205_01</p>	<p>AA00.558.211</p> <p>Support ring</p> <ul style="list-style-type: none"> • Removing planetary gearset 3, page 50 	1	for pot 3
 <p>50_000206_01</p>	<p>5X46.001.376</p> <p>Assembly pliers</p> <ul style="list-style-type: none"> • Removing ring gear 4, page 53 	1	
 <p>50_000259_01</p>	<p>AA00.666.400</p> <p>Bar</p> <ul style="list-style-type: none"> • Removing output, page 53 	1	for output sealing sleeve and drawn cup needle roller bearing



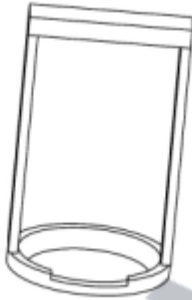
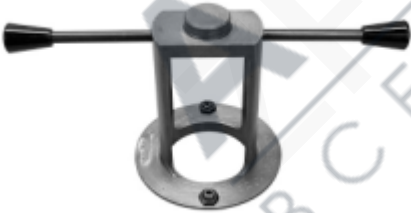

Figure	Order no. Designation Chapter/Section	Qty.	Comment
 <p>50_000207_01</p>	<p>5X46.001.502</p> <p>Assembly fixture</p> <ul style="list-style-type: none"> • Dismantling oil supply, page 56 • Assembling brake A, page 114 	1	for disk spring of clutch A
 <p>50_000269_01</p>	<p>AA00.566.429</p> <p>Disassembly device</p> <ul style="list-style-type: none"> • Dismantling pump, page 59 	1	to loosen pump from intermediate plate
 <p>50_100084_01</p>	<p>5X46.909.248</p> <p>Downholder</p> <ul style="list-style-type: none"> • Dismantling clutch E, page 61 • Dismantling clutch C, page 63 	1	
 <p>50_000249_01</p>	<p>AA00.349.340</p> <p>Assembly fixture</p> <ul style="list-style-type: none"> • Dismantling clutch D, page 65 • Assembling clutch D, page 99 	1	for baffle plate of clutch D
 <p>50_000384_01</p>	<p>5P01.001.330</p> <p>Measuring device</p> <ul style="list-style-type: none"> • Setting running clearance of clutch D, page 68 • Setting running clearance of clutch C, page 72 • Setting running clearance of clutch E, page 76 • Setting running clearance of brake A, page 79 	1	Part 1 of 3

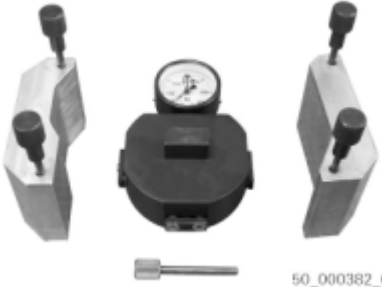
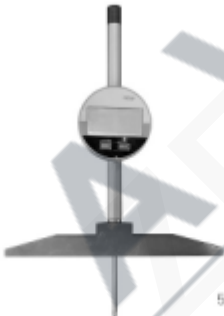

Figure	Order no. Designation Chapter/Section	Qty.	Comment
	<ul style="list-style-type: none"> Setting running clearance of brake B, page 83 		
 <p>50_000383_01</p>	<p>5P01.001.458</p> <p>Test device</p> <ul style="list-style-type: none"> Setting running clearance of clutch D, page 68 Setting running clearance of clutch C, page 72 Setting running clearance of clutch E, page 76 Setting running clearance of brake A, page 79 Setting running clearance of brake B, page 83 	1	Part 2 of 3
 <p>50_000382_01</p>	<p>5P01.000.329</p> <p>Test device</p> <ul style="list-style-type: none"> Setting running clearance of clutch D, page 68 Setting running clearance of clutch C, page 72 Setting running clearance of clutch E, page 76 Setting running clearance of brake A, page 79 Setting running clearance of brake B, page 83 	1	Part 3 of 3
 <p>50_000381_01</p>	<p>5P33.000.009 / 5P74.001.051</p> <p>Measuring bar with dial gage</p> <ul style="list-style-type: none"> Setting running clearance of clutch D, page 68 Setting running clearance of brake A, page 79 Setting running clearance of brake B, page 83 	1	Only use together. Measuring tool for clutch running clearance
 <p>50_000380_01</p>	<p>5P70.000.130</p> <p>Height measuring device</p> <ul style="list-style-type: none"> Setting running clearance of clutch C, page 72 Setting running clearance of clutch E, page 76 	1	Only use together with a measuring plate.





Figure	Order no. Designation Chapter/Section	Qty.	Comment
 <p>50_000247_01</p>	<p>5P01.000.347</p> <p>Measurement stand</p> <ul style="list-style-type: none"> • Setting backlash, page 86 	1	
 <p>50_000267_01</p>	<p>5X54.909.282</p> <p>Press-in device</p> <ul style="list-style-type: none"> • Fitting output, page 93 	1	for output needle roller bearing / drawn cup needle roller bearing
 <p>50_000266_01</p>	<p>5X54.909.281</p> <p>Press-in device</p> <ul style="list-style-type: none"> • Fitting output, page 93 	1	for output sealing sleeve
 <p>50_000263_01</p>	<p>5X46.002.561</p> <p>Press-in mandrel</p> <ul style="list-style-type: none"> • Assembling parking lock, page 95 • Assembling oil supply, page 111 	1	Shaft sealing ring of selector shaft
 <p>50_000248_01</p>	<p>5X46.001.368</p> <p>Press-in device</p> <ul style="list-style-type: none"> • Assembling parking lock, page 95 	1	for clamping sleeve

Figure	Order no. Designation Chapter/Section	Qty.	Comment
 <p>50_000293_01</p>	<p>AA00.533.332</p> <p>Assembly fixture</p> <ul style="list-style-type: none"> • Assembling clutch C, page 103 	1	for snap ring of clutch C
 <p>50_100083_01</p>	<p>AA00.858.018</p> <p>Assembly fixture</p> <ul style="list-style-type: none"> • Assembling clutch E, page 106 	1	for round wire ring of clutch E
 <p>50_000253_01</p>	<p>5X46.003.913</p> <p>Assembly fixture</p> <ul style="list-style-type: none"> • Installing pump, page 109 	1	to press in pump into intermediate plate
 <p>50_000294_01</p>	<p>AA00.613.941</p> <p>Press-in mandrel</p> <ul style="list-style-type: none"> • Assembling oil supply, page 111 	1	
 <p>50_000251_01</p>	<p>AA00.602.553</p> <p>Turning device</p> <ul style="list-style-type: none"> • Assembling oil supply, page 111 	1	to screw down pump and intermediate plate





Figure	Order no. Designation Chapter/Section	Qty.	Comment
 <p>50_000270_01</p>	<p>AA00.548.688</p> <p>Assembly pliers</p> <ul style="list-style-type: none"> • Installing planetary gearset 3, page 121 • Installing planetary gearset 1, page 128 	1	for snap ring at planetary gearset 3/pot 3 and pot 1
 <p>50_000296_01</p>	<p>5X46.003.918</p> <p>Mounting tool</p> <ul style="list-style-type: none"> • Installing planetary gearset 2, page 125 	1	for snap ring of planetary gearset 2
 <p>50_000264_01</p>	<p>AA00.381.834</p> <p>Assembly fixture</p> <ul style="list-style-type: none"> • Installing planetary gearset 2, page 125 	1	for rectangular rings
 <p>50_000250_01</p>	<p>AA00.616.414</p> <p>Assembly fixture</p> <ul style="list-style-type: none"> • Installing tower, page 130 	1	to drive in cylindrical pin into transmission housing
 <p>50_000265_01</p>	<p>AA00.549.949</p> <p>Test device</p> <ul style="list-style-type: none"> • Installing tower, page 130 	1	for rectangular rings on input shaft

Figure	Order no. Designation Chapter/Section	Qty.	Comment
 <p>50_000297_01</p>	<p>AA00.373.240</p> <p>Sealing device</p> <ul style="list-style-type: none"> • Installing oil supply, page 133 	1	to check clutch for leakages
 <p>50_000298_01</p>	<p>AA00.575.099</p> <p>Assembly fixture</p> <ul style="list-style-type: none"> • Fitting output, page 141 	1	for output snap ring
 <p>50_000268_01</p>	<p>5X46.004.217</p> <p>Assembly fixture</p> <ul style="list-style-type: none"> • Fitting output, page 141 	1	for output shaft sealing ring

8 Preparatory Activities

8.1 Loading the transmission

Special tools:

- 5T66.000.286 Assembly bracket

⚠ WARNING

Risk of injury due to falling parts.

Death or serious injury possible.

- ⇒ Secure parts against falling down.
- ⇒ Do not stand beneath a suspended load.
- ⇒ Do not work on a suspended load.

1. Attach 5T66.000.286 [Assembly bracket] at the transmission.
2. Mount transmission to assembly trolley or workbench bracket with oil pan facing downwards using the assembly bracket.

8.2 Draining transmission oil

Requirements:

- Suitable container to collect oil

Unscrew screw plugs

1. Put container under oil drain plug.
2. Unscrew oil drain plug from oil pan.

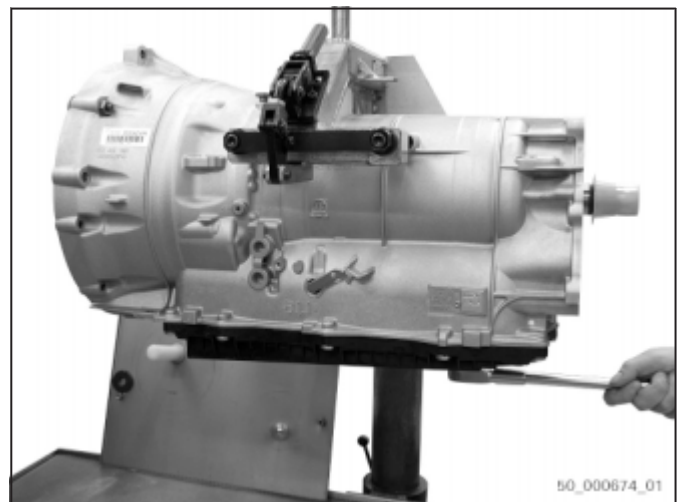

Fig. 3

→ Once the transmission oil has been completely drained, unscrew all other screw plugs.

9 Dismantling

9.1 Removing torque converter

Special tools:

- 5X46.002.807 Lifting gear

⚠ WARNING

**Risk of injury due to falling parts.
Death or serious injury possible.**

- ⇒ Secure parts against falling down.
- ⇒ Do not stand beneath a suspended load.
- ⇒ Do not work on a suspended load.

1. Place transmission with input end facing upwards.
2. Unscrew three torx screws from torque converter retaining bracket.
3. Remove torque converter retaining bracket.

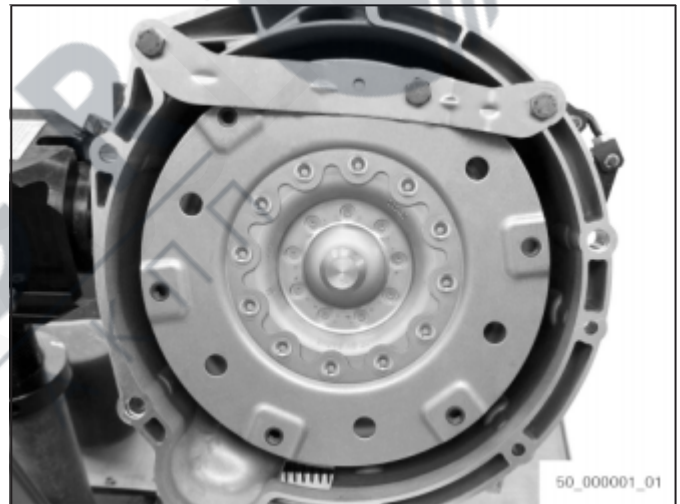

Fig. 4

4. Attach 5X46.002.807 [Lifting gear] at torque converter.
5. Fit crane into 5X46.002.807 [Lifting gear].
6. Remove torque converter.



Fig. 5

9.2 Removing output

Special tools:

- AA00.648.882 Disassembly device
- AA00.589.201 Assembly pliers



Measure backlash and compare to backlash value measured during assembly.

1. Place transmission with output end facing upwards.
2. Put AA00.648.882 [Disassembly device] on the transmission housing over input shaft.

3.

NOTICE

Damage due to leakage possible. Do not damage sealing face.

⇒ Carefully remove sealing element.

Remove output shaft sealing ring using a screwdriver.

4. Remove snap ring from output shaft using AA00.589.201 [Assembly pliers].

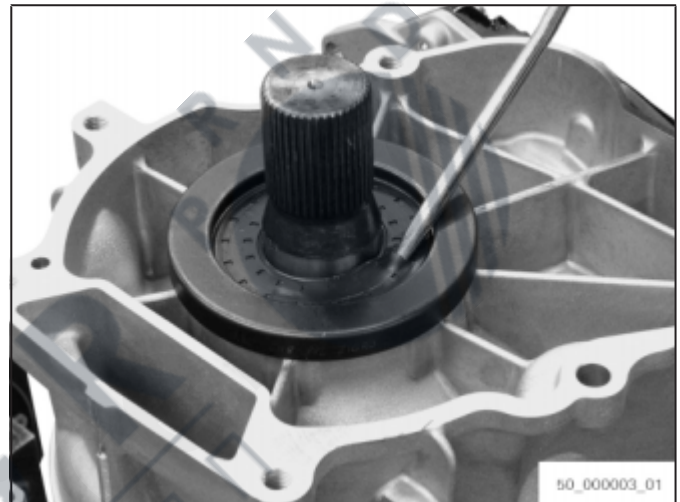

Fig. 6



Fig. 7

5. Remove thrust washer from output shaft.

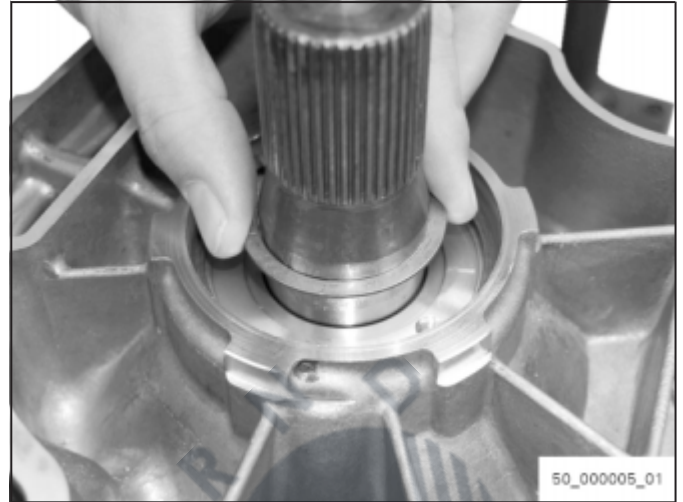



Fig. 8

9.3 Removing oil pan

1. Place transmission with oil pan facing upwards.
2.  Seal is integrated into oil pan. Torx screws of oil pan are protected against loss.

Unscrew 13 torx screws from oil pan.

3. Remove oil pan.

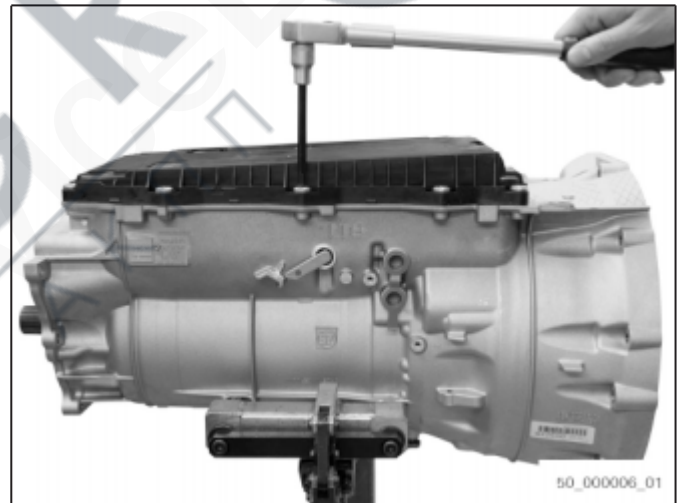

Fig. 9

9.4 Removing Mechatronic and hydraulic impulse oil storage

9.4.1 Removing hydraulic impulse oil storage

NOTICE

Property damage due to electrostatic discharge (ESD) possible.

- ⇒ Observe ESD protection.
- ⇒ Do not touch contacts.
- ⇒ Wear conductive workwear.
- ⇒ Use ESD transport protection.
- ⇒ Use ESD protective packaging.

1. Remove cable plug from HIS and insert into parking position.



Fig. 10

2. Unscrew three torx screws from HIS.
3. Carefully remove HIS.



Fig. 11

4.

NOTICE
Property damage due to leakage at delivery connection of HIS possible.
⇒ Remove O-ring without tool.



Remove O-ring from HIS.

Fig. 12

9.4.2 Removing Mechatronic

Special tools:

- AA01.200.270 Holding device
- AA00.548.098 Disassembly device

1. Slide AA01.200.270 [Holding device] onto selector shaft and lock in place.

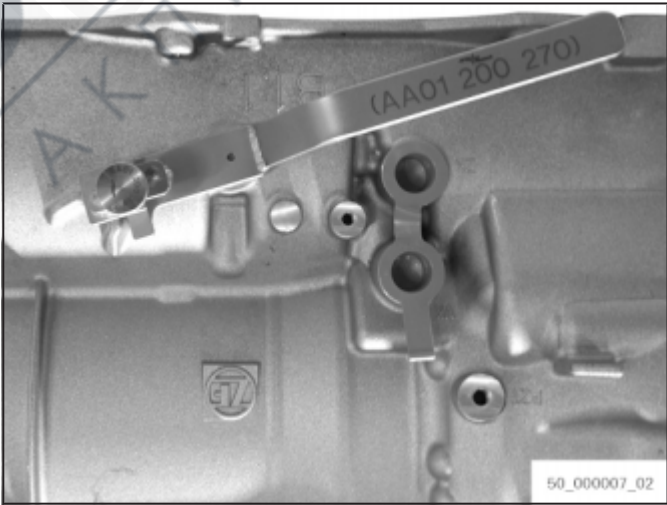

Fig. 13

2. Unscrew three short torx screws from module, output speed sensor and guiding sleeve securing device.

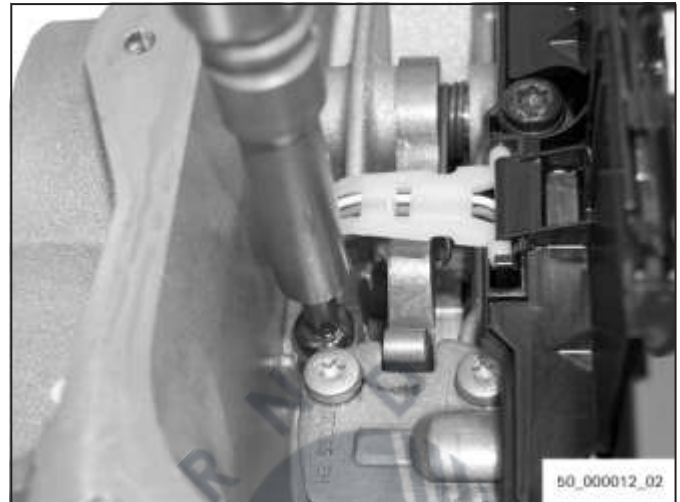

Fig. 14

3.

NOTICE

The dog point at the output speed sensor might break during disassembly or assembly.

⇒ Carefully insert output speed sensor into parking position.

Carefully remove output speed sensor and insert into parking position of module.



Fig. 15

4. Unlock retaining clamp.
5. Pull off guiding sleeve using AA00.548.098 [Disassembly device].



Fig. 16

Dismantling

6. Unscrew 14 torx screws from Mechatronic.

7.  Mechatronic might be jammed.

Carefully unfasten and remove Mechatronic.

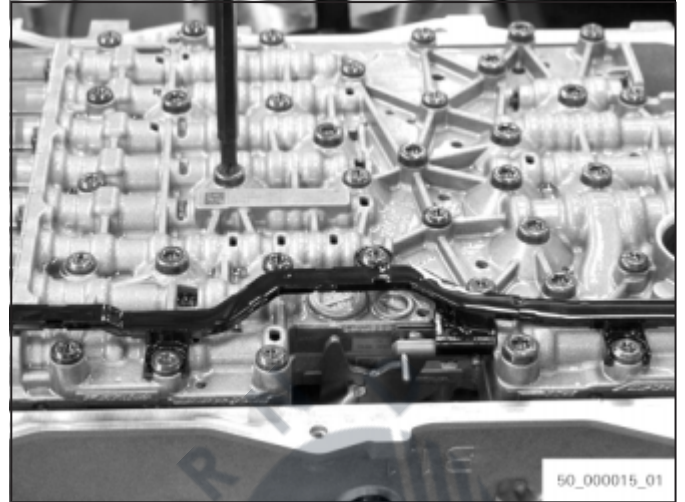



Fig. 17

8.  Pressure tube might get stuck in transmission housing or in Mechatronic.

Remove pressure tube from Mechatronic.

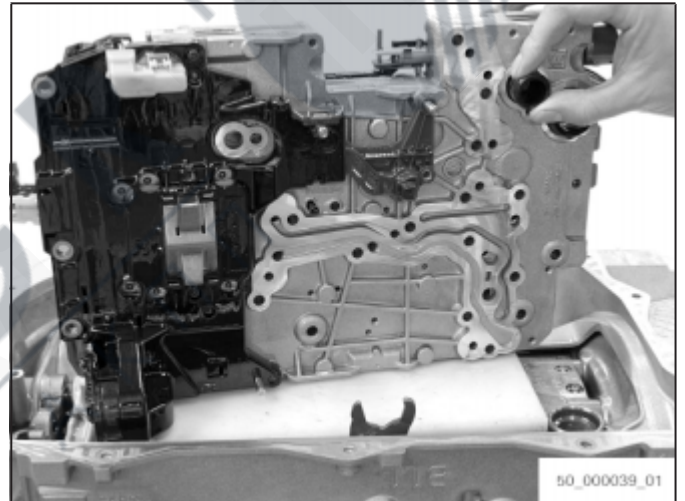

Fig. 18

9.5 Removing parking lock

Special tools:

- AA01.200.270 Holding device

1. Unscrew three torx screws from guiding plate.
2. Remove guiding plate.

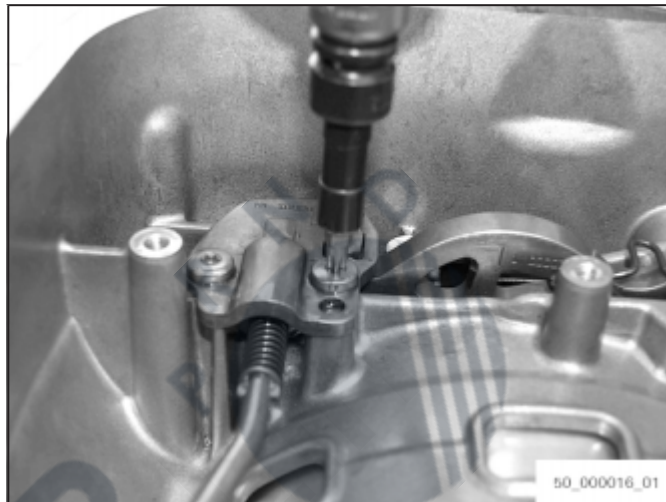

Fig. 19

3. Unscrew screw plug of parking lock bolt.

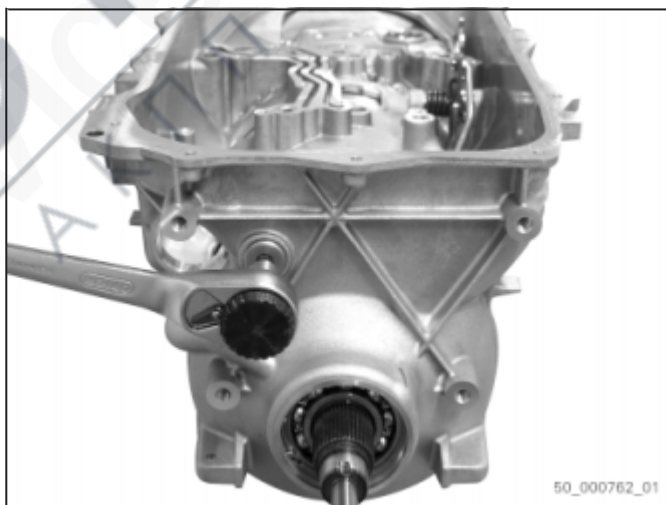

Fig. 20

Dismantling

4. Unscrew hexagon socket.
5. Eject parking lock bolt.
6. Remove ratchet and spiral spring.

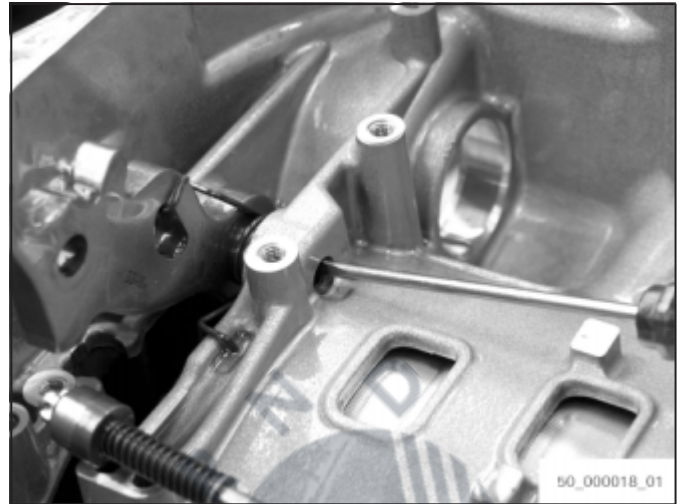

Fig. 21

7. Remove connecting rod from parking disk.
8. Remove AA01.200.270 [Holding device] from selector shaft.
9. Drive out straight pin of selector shaft using suitable tool.

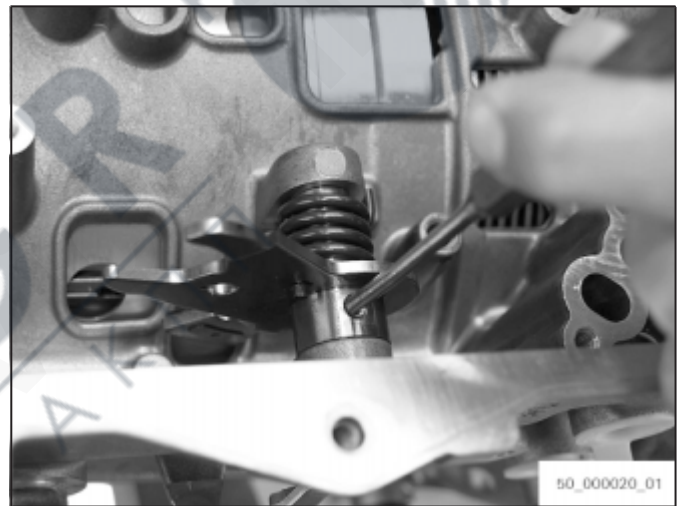

Fig. 22

10. Remove selector shaft, parking disk and spiral spring.



Fig. 23

11.

NOTICE

Damage due to leakage possible. Do not damage sealing face.

⇒ Carefully remove sealing element.

Remove shaft sealing ring of selector shaft using suitable tool.

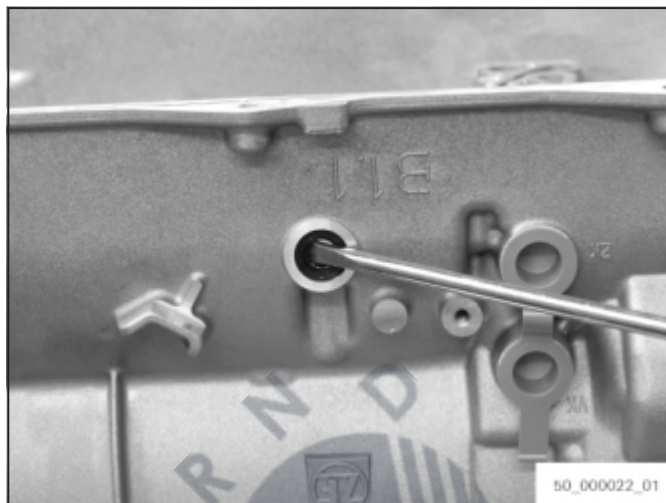

Fig. 24

9.6 Removing oil supply

Special tools:

- AA00.549.802 Disassembly device

1. Remove O-ring from output shaft.



Fig. 25

2. Place transmission housing with torque converter end facing upwards.
3. Unscrew 14 torx screws from oil supply.



Fig. 26

4. Put AA00.549.802 [Disassembly device] on oil supply.
5. Lock locking device of AA00.549.802 [Disassembly device].
6. Turn threaded spindle clockwise until oil supply comes loose.
7. Remove oil supply.

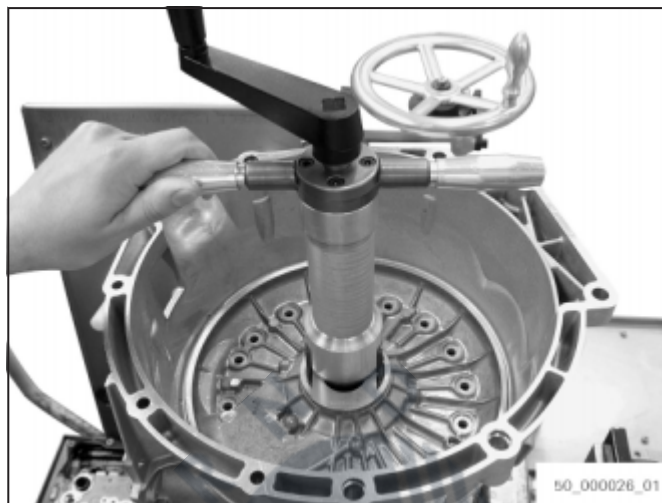

Fig. 27

AVTIGRIP
ВСЕ ДЛЯ АКПП

Dismantling

9.7 Removing tower

9.7.1 Lifting out tower

Special tools:

- 5X46.003.957 Tower lifting device

⚠ WARNING

**Risk of injury due to falling parts.
Death or serious injury possible.**

- ⇒ Secure parts against falling down.
- ⇒ Do not stand beneath a suspended load.
- ⇒ Do not work on a suspended load.

1. Remove spring assembly from tower.



Fig. 28

2. Put 5X46.003.957 [Tower lifting device] on input shaft.
3. Lock locking device of 5X46.003.957 [Tower lifting device].
4. Lift out tower using crane.

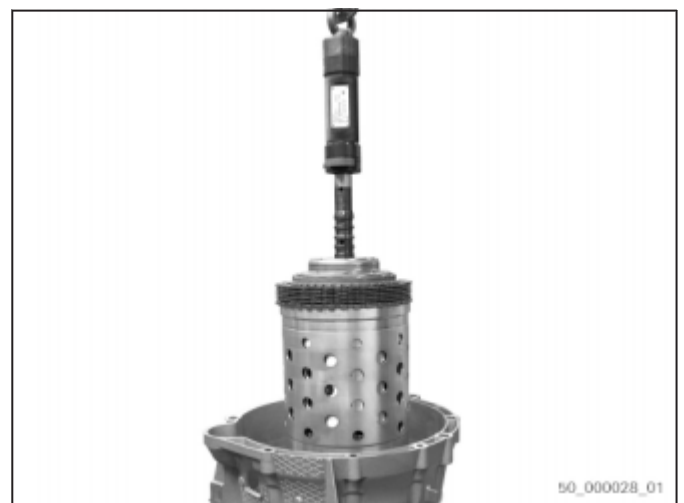

Fig. 29

9.7.2 Dismantling tower

Special tools:

- 5X46.004.264 Assembly fixture
- AA00.555.684 Support ring

1. Put tower into 5X46.004.264 [Assembly fixture].
2. Remove tower lifting device.
3. Remove multidisk package of brake B.

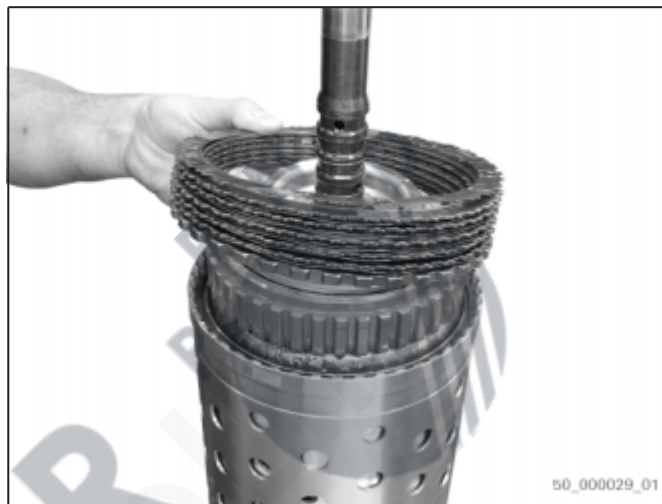

Fig. 30

4. Remove adjustment plate for axial clearance of ring gear.
5. Remove multidisk carrier B/ring gear 1.



Fig. 31

Dismantling

- 6. Loosen and remove needle roller bearing from planet carrier using a screwdriver.

7. **NOTICE**
Locking dog point and oil feed dog point at the oil drip pan might break off.
⇒ To pry out, place screwdriver at several spots.

Pry out oil drip pan from planetary gerset 1 using a screwdriver.



Fig. 32

- 8. Put AA00.555.684 [Support ring] on pot 1.
- 9. Pry out snap ring on opposite side of snap ring opening using a screwdriver.



Fig. 33

9.7.3 Dismantling planetary gerset 1

- 1. Remove planetary gerset 1.



Fig. 34

2. Remove sun gear 1/2.



Fig. 35

3. Loosen thrust washer from sun gear/
planetary gearset 2 using a screwdriver.



Fig. 36

9.7.4 Dismantling planetary gearset 2

Special tools:

- AA00.686.190 Supporting plate
- AA00.589.201 Assembly pliers

1. Remove input shaft with planetary gearset 2.
2. Fit input shaft into AA00.686.190 [Supporting plate].



Fig. 37

3. Pull off seven rectangular rings from the input shaft.



Fig. 38

4. Remove thrust washer from planet carrier 2.



Fig. 39

- 5.

NOTICE

Locking dog point and oil feed dog point at the oil drip pan might break off.

⇒ To pry out, place screwdriver at several spots.

Pry out oil drip pan from planet carrier 2 using a screwdriver.

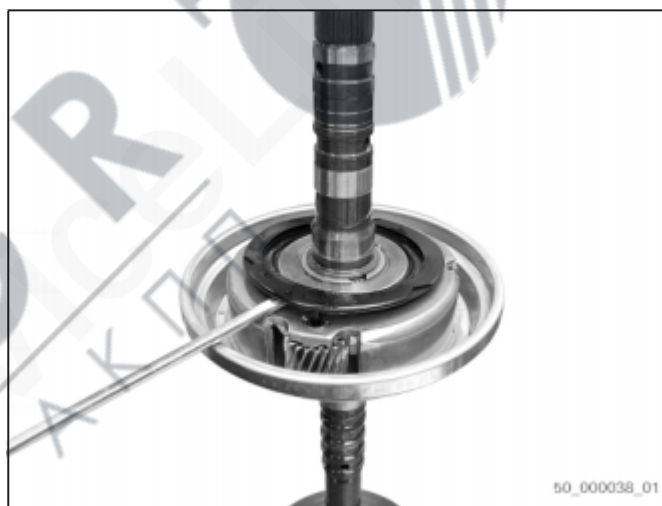

Fig. 40

6. Remove snap ring using AA00.589.201 [Assembly pliers].

7. Remove planetary gearset 2.



Fig. 41

9.7.5 Removing ring gear 2

1. Remove axial needle bearing from ring gear 2.



Fig. 42

2. Remove ring gear 2/sun gear 3 from planet spider 3.



Fig. 43

3. Turn over ring gear 2/sun gear 3.
4. Remove angle disk from sun gear 3.
5. Remove snap ring from ring gear 2/sun gear 3.



Fig. 44

9.7.6 Removing pot 3 from pot 1

Special tools:

- 5X46.004.264 Assembly fixture

1. Remove pot 3 from pot 1.



Fig. 45

2. Remove clutch D from pot 1.
3. Remove pot 1 from 5X46.004.264 [Assembly fixture].
4. Put pot 3 into 5X46.004.264 [Assembly fixture].



Fig. 46

9.7.7 Removing planetary gearset 3

Special tools:

- AA00.558.211 Support ring

1. Put AA00.558.211 [Support ring] on pot 3.
2. Pry out snap ring on opposite side of snap ring opening using a screwdriver.

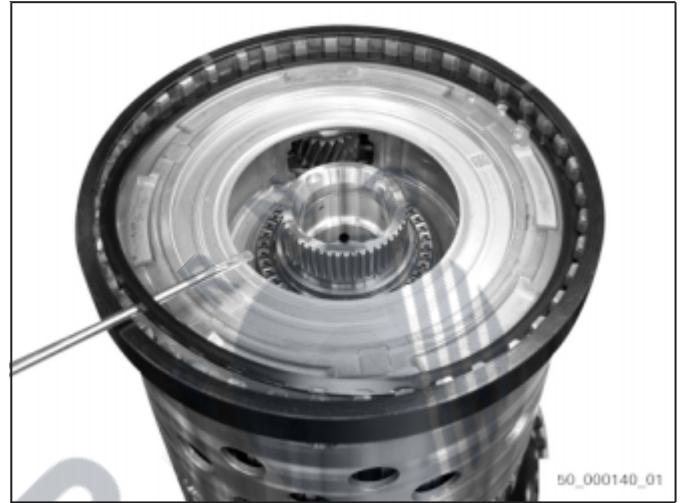

Fig. 47

3. Remove planet spider 3 from pot 3.
4. Remove axial needle bearing from planetary gearset 3.



Fig. 48

5. Remove upper snap ring using a screwdriver.

6. Remove ring gear 3.



Fig. 49

7. Remove lower snap ring using a screwdriver.



Fig. 50

9.7.8 Removing clutch E/C

1. Remove clutch E.

2. Remove axial needle bearing from clutch E.



Fig. 51

Dismantling

3. Remove clutch C.
4. Remove combination bearing at upper side and combination bearing at lower side of clutch C.



Fig. 52

5. Remove sun shaft/sun gear 4 from pot 3.



Fig. 53

9.7.9 Removing ring gear 4

Special tools:

- 5X46.001.376 Assembly pliers

1. Loosen snap ring from pot 1 using 5X46.001.376 [Assembly pliers].
2. Remove ring gear 4 from pot 1.

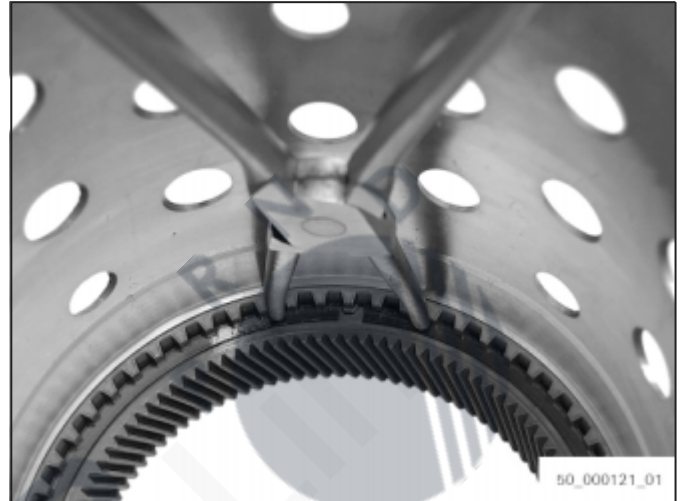

Fig. 54

9.8 Removing output

Special tools:

- AA00.666.400 Bar

1. Place transmission housing with input end facing downwards.

2.

NOTICE

Damage due to leakage possible. Do not damage sealing face.

⇒ Carefully remove snap ring.

Remove snap ring from supporting ring.



Fig. 55

Dismantling

3. Remove supporting ring.

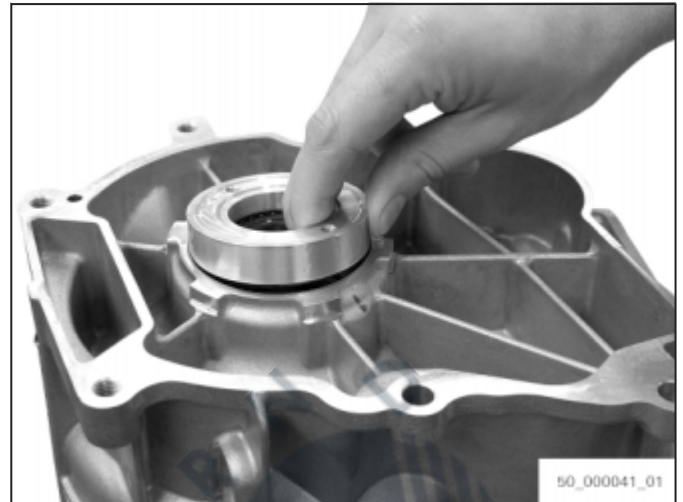

Fig. 56

4. Remove axial needle bearing from supporting ring using a screwdriver.

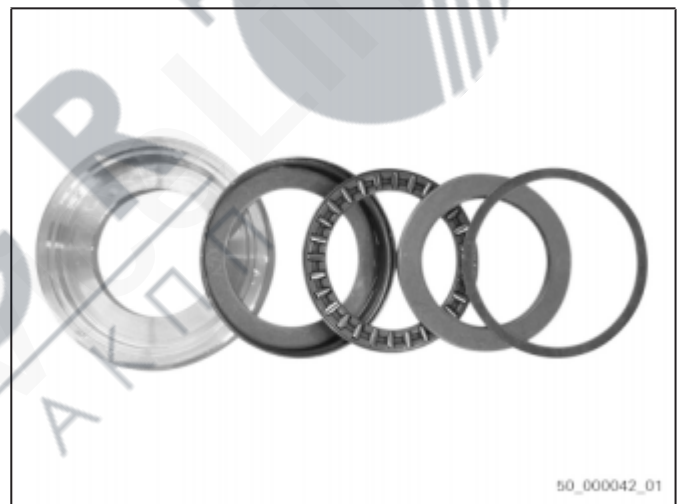

Fig. 57

5. Remove snap ring.
6. Place transmission housing with input end facing upwards.



Fig. 58

- Remove sealing sleeve using AA00.666.400 [Bar].



Fig. 59

- Place transmission housing with output end facing upwards.
- Remove snap ring.
- Place transmission housing with output end facing downwards.



Fig. 60

- Drive out drawn cup needle roller bearing using AA00.666.400 [Bar].



Fig. 61

9.9 Dismantling oil supply

Special tools:

- 5X46.001.502 Assembly fixture

1. Remove piston B from intermediate plate.



Fig. 62

2. Pull off lipped seal ring from piston B.
3. Pull off lipped seal ring from intermediate plate.

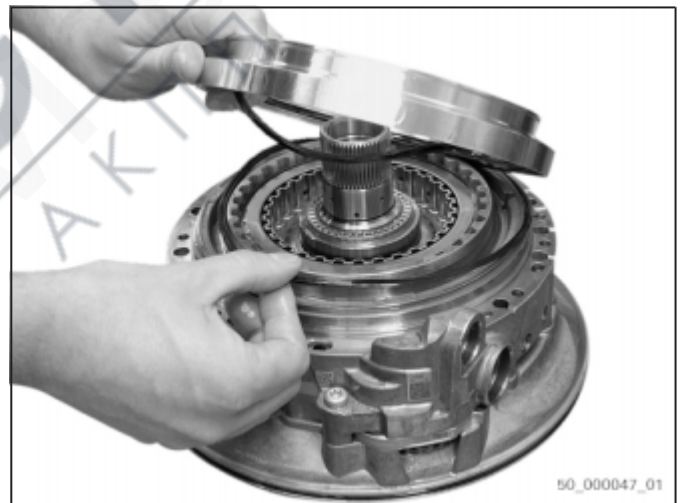

Fig. 63

4. Remove axial needle bearing from sun shaft 1.

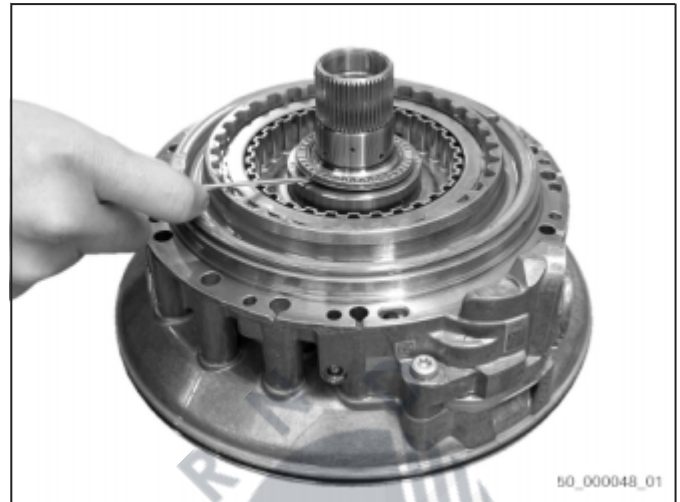

Fig. 64

5. Remove snap ring of brake A.
6. Remove sun shaft 1 with multidisk package of brake A.
7. Remove wave spring and outer clutch disk.

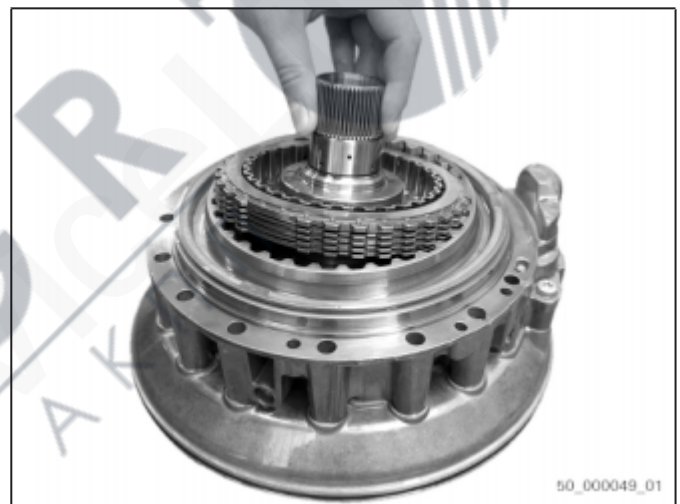

Fig. 65

8. Remove axial needle bearing and angle disk from oil supply.



Fig. 66

Dismantling

- 9. Place 5X46.001.502 [Assembly fixture] on piston A in arbor press.
- 10. Preload piston A.
- 11. Remove split ring and disk spring from piston A.



Fig. 67

- 12. Remove piston A.
- 13. Pull off two lipped seal rings from piston A.



Fig. 68

- 14. Unfasten six torx screws in cylinder A and one torx screw outside of the cylinder.
- 15. Separate intermediate plate and centering plate.
- 16. Pull off O-ring from centering plate.

- 17.

NOTICE
Damage due to leakage possible. Do not damage sealing face.
⇒ Carefully remove sealing element.



Fig. 69

Remove shaft sealing ring from centering plate using suitable tool.

9.10 Dismantling pump

Special tools:

- AA00.566.429 Disassembly device

1. Carefully remove pump and chain wheel using AA00.566.429 [Disassembly device].

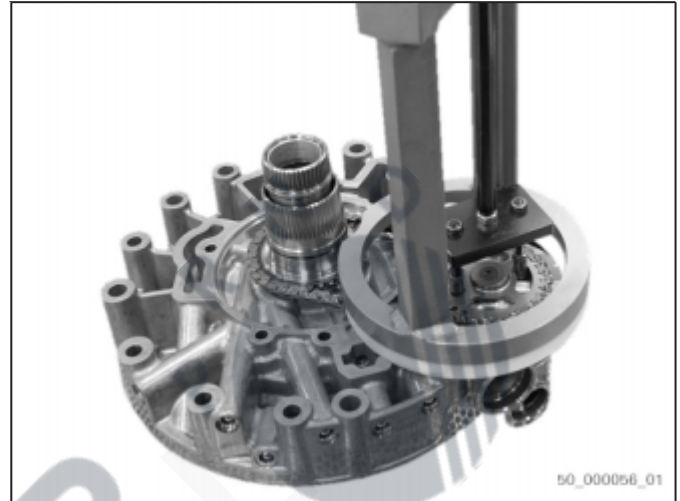

Fig. 70

2. Pull off O-ring from chain wheel.

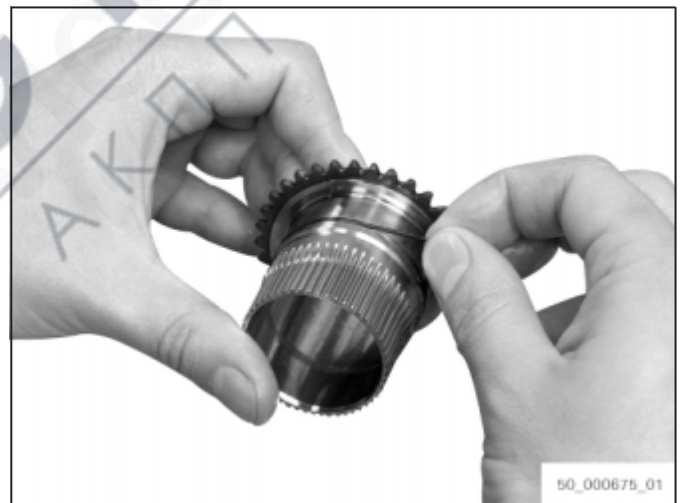

Fig. 71

Dismantling

3. Remove two O-rings from pump.
4. Turn around pump.



Fig. 72

5. Remove sealing element from pump.

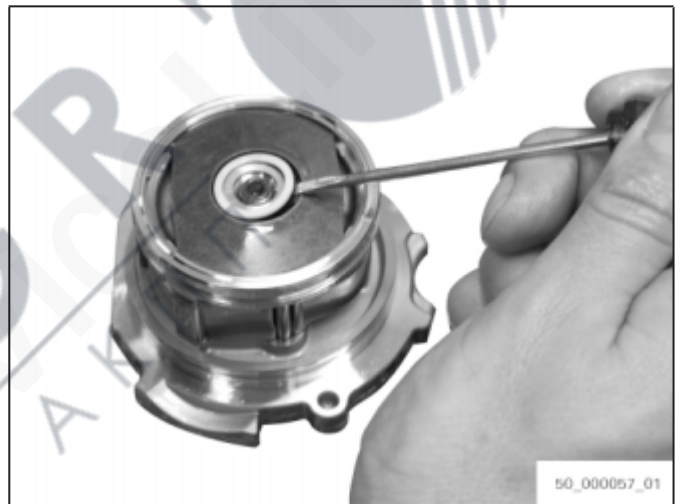

Fig. 73

9.11 Dismantling clutch E

Special tools:

- 5X46.909.248 Downholder
1. Position 5X46.909.248 [Downholder] on supporting ring in arbor press.
 2. Preload supporting ring.
 3. Remove round wire ring.

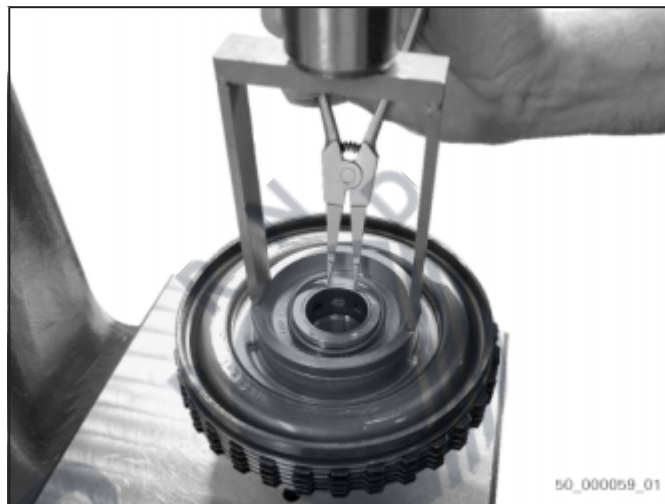



Fig. 74

4.  Sealing element cannot be replaced. In case of damage, replace complete component.

Remove piston E with supporting ring.

5. Remove supporting ring from piston E.
6. Pull off lipped seal ring from supporting ring.



Fig. 75

7. Remove disk spring and multidisk package.



Fig. 76

- 8.

NOTICE

Damage due to leakage possible. Do not damage sealing face.

⇒ Carefully remove sealing element.

Remove two O-rings from cylinder E.

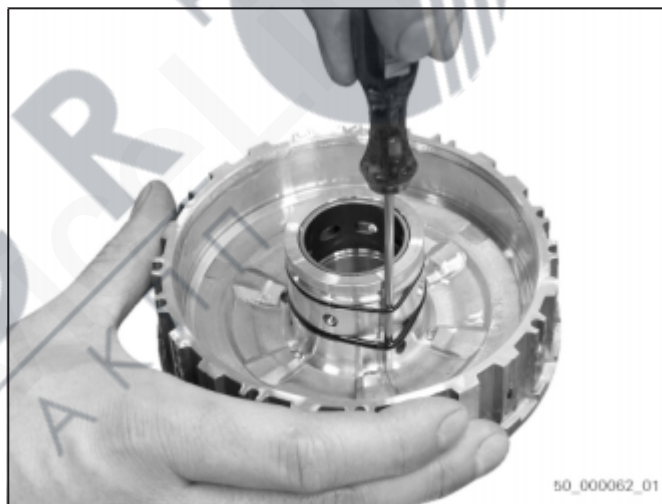

Fig. 77

9.12 Dismantling clutch C

Special tools:

- 5X46.909.248 Downholder
1. Position 5X46.909.248 [Downholder] on supporting ring in arbor press.
 2. Preload supporting ring.
 3. Remove snap ring.



Fig. 78

4.  Sealing element cannot be replaced. In case of damage, replace complete component.

Remove piston C with supporting ring.

5. Remove supporting ring from piston C.
6. Pull off lipped seal ring from supporting ring.



Fig. 79

Dismantling

- 7. Remove disk spring and multidisk package.

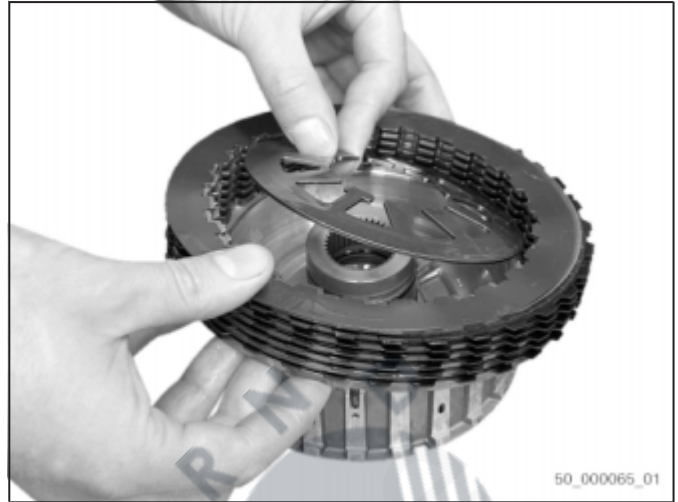

Fig. 80

- 8. Remove multidisk carrier.

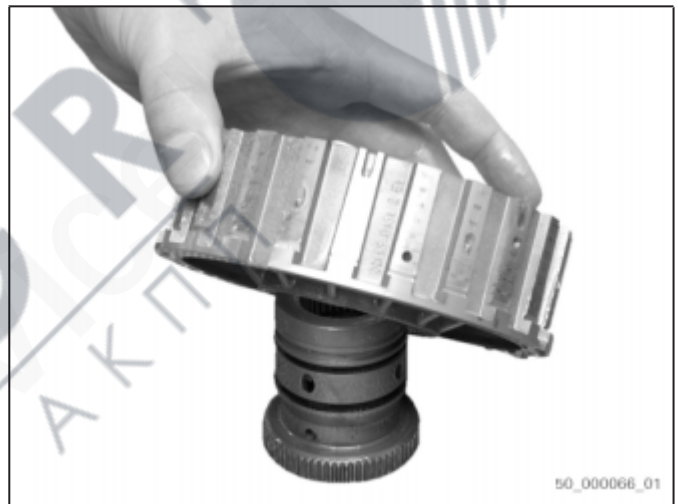

Fig. 81

- 9.

NOTICE

Damage due to leakage possible. Do not damage sealing face.

⇒ Carefully remove sealing element.

Remove two O-rings inside and two O-rings outside of the hub.



Fig. 82

9.13 Dismantling clutch D

Special tools:

- 5X46.004.264 Assembly fixture
- AA00.349.340 Assembly fixture

1. Put clutch D into 5X46.004.264 [Assembly fixture].
2. Remove snap ring using a screwdriver.



Fig. 83

3. Remove multidisk package from clutch D.

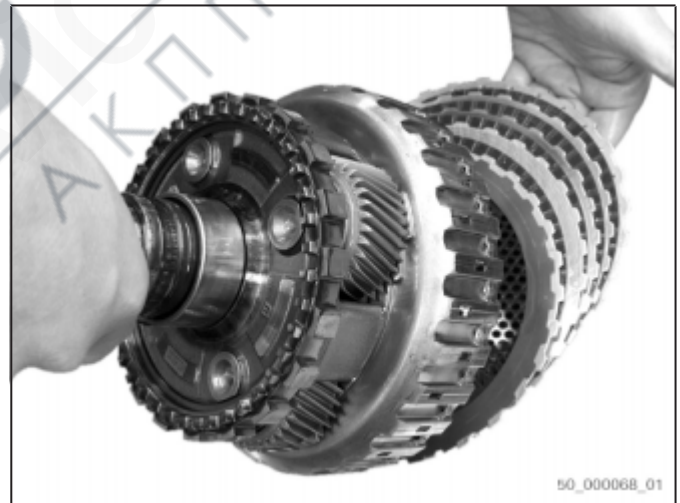

Fig. 84

Dismantling

4. Put AA00.349.340 [Assembly fixture] with both pins into the recesses of the baffle plate. Ensure correct position.
5. Insert baffle plate with downholder into arbor press and preload.

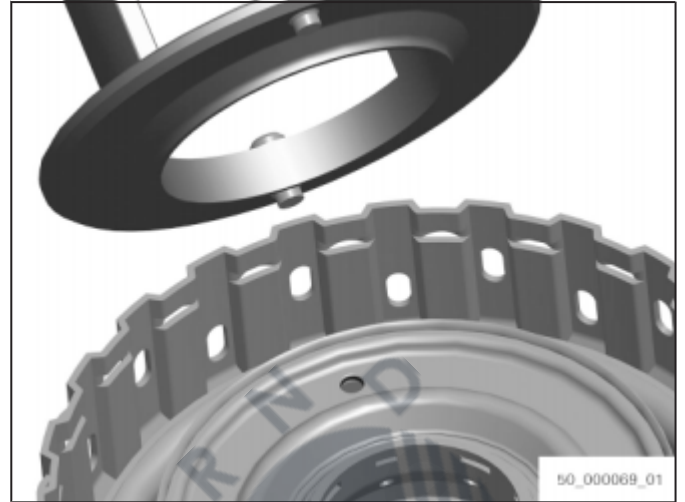

Fig. 85

6. Rotate tool clockwise until dog points snap out of place.



Fig. 86

7. Remove baffle plate and disk spring.
8. Pull off O-ring from baffle plate.



Fig. 87

9. Pull out piston D by hand.



Fig. 88

10. Pull of O-ring from piston D.



Fig. 89

11. Turn over output shaft.
12. Remove two rectangular rings from output shaft.



Fig. 90

10 Testing, Measuring, Adjusting

10.1 Setting running clearance of clutch D

Special tools:

- 5P01.001.330 Measuring device
- 5P01.001.458 Test device
- 5P01.000.329 Test device
- 5P33.000.009 / 5P74.001.051 Measuring bar with dial gage

i Composition of multidisk package in this example:

- one wave spring
- four outer clutch disks and four lined clutch disks
- one end disk

The running clearance is set by using the snap ring (73.180).

NOTICE

The composition of the multidisk package depends on the parts list [BoM] and may vary. The composition of the multidisk package affects the setting.

⇒ Observe valid setting specification. The setting specifications are available for download from the ZF-ServiceLine.

Assembling measuring equipment

1. Assemble 5P01.001.330 [Measuring device], 5P01.001.458 [Test device] and 5P01.000.329 [Test device].

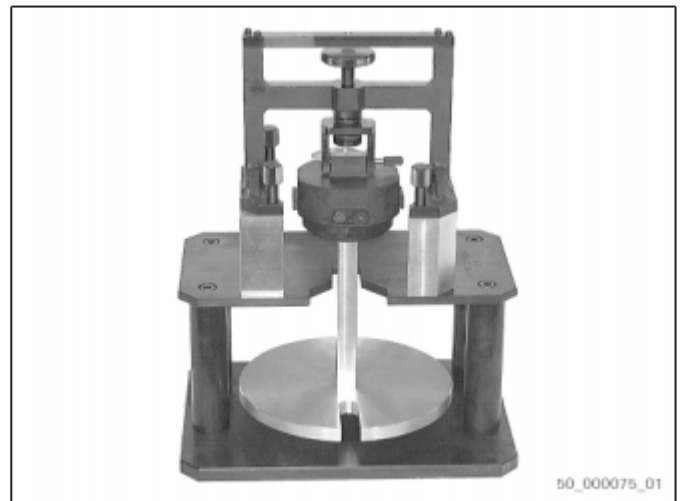

Fig. 91

Determine dimension $h_{\text{Multidisks}}^{1)}$

2. Center multidisk package.
3. Place multidisk package into center of measuring equipment.
4. Set specified preload force.
 $F = 200 \text{ N} \pm 5 \text{ N}$

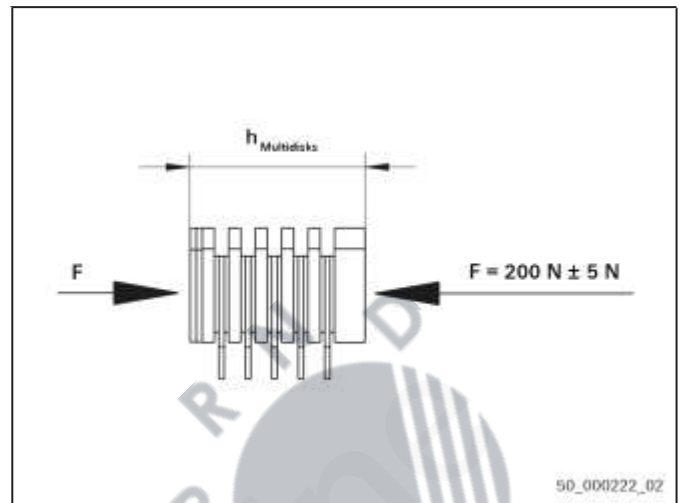



Fig. 92

5.  Do not measure multidisk package on studs.

Put measuring bar with dial gage on pressure plate of measuring device.
6. Put measuring stylus on base plate.
7. Reset dial gage.
8. Measure from base plate to multidisk package.
9. Repeat measurement at three spots.
10. Calculate mean value of $h_{\text{Multidisks}}$: 20,31 mm

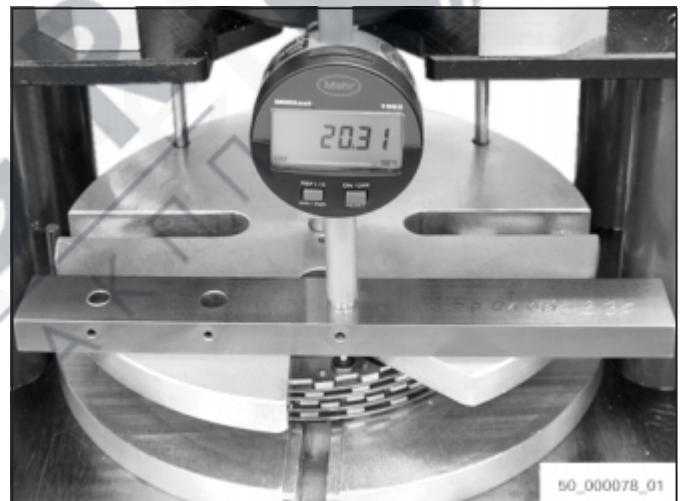

Fig. 93

1) Overall height of multidisk package

Determine dimension $h_{\text{Piston/Snap ring groove}}^2)$

11. Put 5P33.000.009 / 5P74.001.051 [Measuring bar with dial gage] on cylinder D.
12. Put measuring stylus on piston D and reset dial gage.



Fig. 94

13. Measure from piston D to upper edge of snap ring groove.
14. Repeat measurement at three spots.
15. Calculate mean value of $h_{\text{Piston/Snap ring groove}}$: 21.86 mm

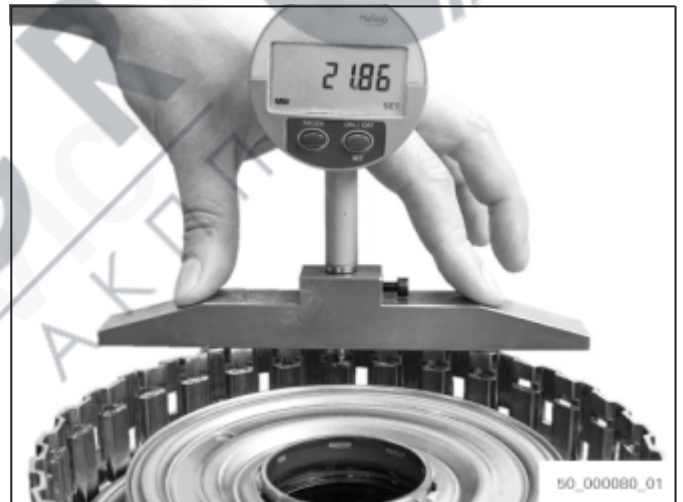

Fig. 95

2) Dimension of height of piston to snap ring groove

Formulas for calculating the running clearance

$$16. \quad h_{\text{Available space}} = h_{\text{Piston/Snap ring groove}} + h_{\text{Measuring stylus}}$$

Exemplary calculation:

$$h_{\text{Available space}} = 21.86 \text{ mm} + 1.80 \text{ mm}$$

$$h_{\text{Available space}} = 23.66 \text{ mm}$$

$$17. \quad h_{\text{Running clearance}} = h_{\text{Available space}} - h_{\text{Multidisks}} - h_{\text{Snap ring}}$$

Exemplary calculation:

$$h_{\text{Running clearance}} = 23.66 \text{ mm} - 20.31 \text{ mm} - 2.0 \text{ mm}$$

$$h_{\text{Running clearance}} = 1.35 \text{ mm}$$

$$18. \quad \text{Running clearance tolerance of clutch D} \\ 1.33 \text{ mm} - 1.62 \text{ mm}$$

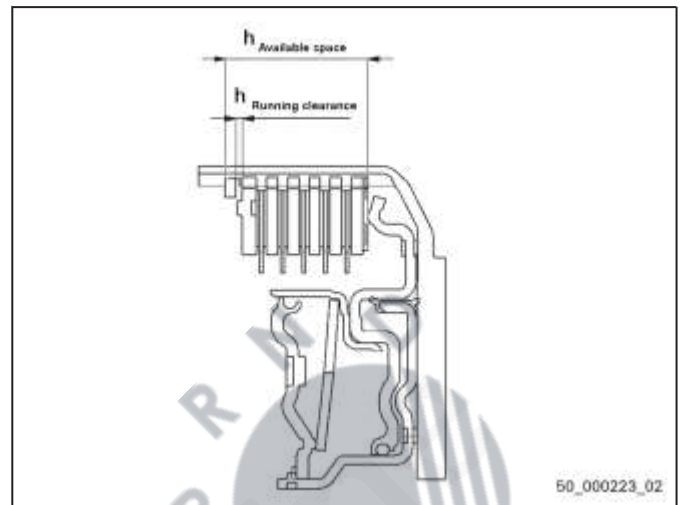

Fig. 96

→ With 1.35 mm, the running clearance is O.K. and is within the permissible tolerance range.

→ If value is outside of the tolerance range, use snap ring of different thickness and remeasure.

10.2 Setting running clearance of clutch C

Special tools:

- 5P01.001.330 Measuring device
- 5P01.001.458 Test device
- 5P01.000.329 Test device
- 5P70.000.130 Height measuring device

i Composition of multidisk package in this example:

- one wave spring
- six inner clutch disks
- six lined clutch disks
- one end disk

The running clearance is set by using the end disk (75.110).

NOTICE

The composition of the multidisk package depends on the parts list [BoM] and may vary. The composition of the multidisk package affects the setting.

⇒ Observe valid setting specification. The setting specifications are available for download from the ZF-ServiceLine.

Assembling measuring equipment

1. Assemble 5P01.001.330 [Measuring device], 5P01.001.458 [Test device] and 5P01.000.329 [Test device].

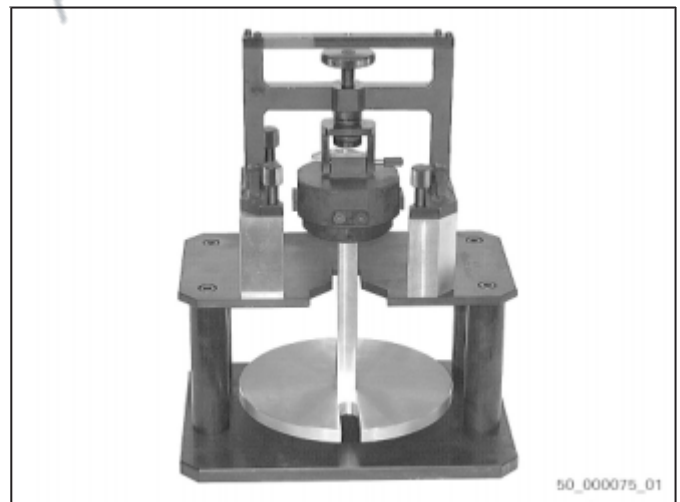

Fig. 97

Determine dimension $h_{\text{Multidisks}}^{3)}$

2. Center multidisk package.

3. **NOTICE**

Measurement results might be falsified.

⇒ Measure multidisk package without end disk.

Place multidisk package into center of measuring equipment.

4. Set specified preload force.

$F = 200 \text{ N} \pm 5 \text{ N}$

5. Put measuring bar with dial gage on pressure plate of measuring device.

6. Put measuring stylus on base plate.

7. Reset dial gage.

8. Measure from base plate to multidisk package.

9. Repeat measurement at three spots.

10. Calculate mean value of $h_{\text{Multidisks}}$: 26.31 mm

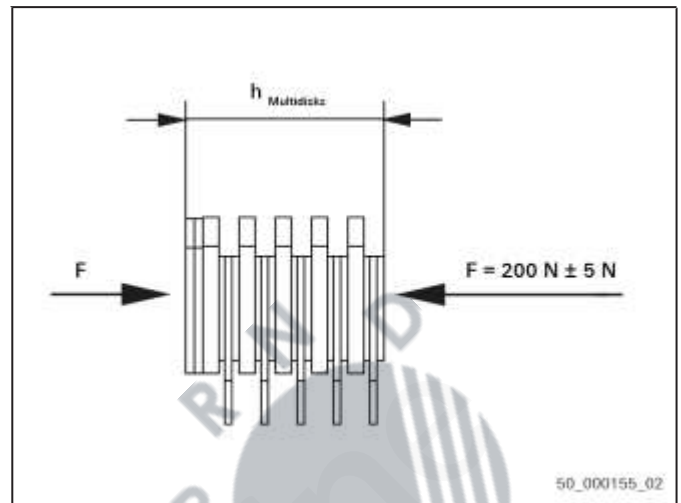

Fig. 98



Fig. 99

3) Overall height of multidisk package

Testing, Measuring, Adjusting

Determine dimension $h_{\text{Available space}}$ ⁴⁾

11. Assemble cylinder C, piston, disk spring, supporting ring and end disk and secure with old snap ring.
12. Put measuring stylus of 5P70.000.130 [Height measuring device] on surface of plate multidisks.
13. Reset 5P70.000.130 [Height measuring device].
14. Measure from surface of plate multidisks to upper edge of end disk.
15. Repeat measurement at three spots.
16. Calculate mean value of $h_{\text{Available space}}$:
28.50 mm

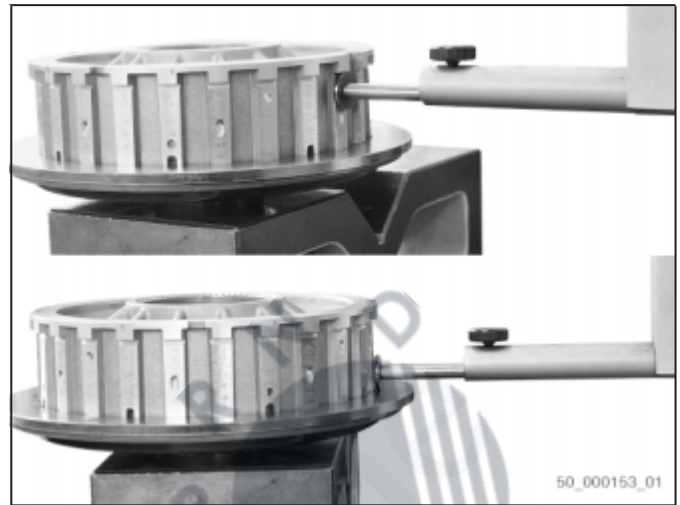

Fig. 100

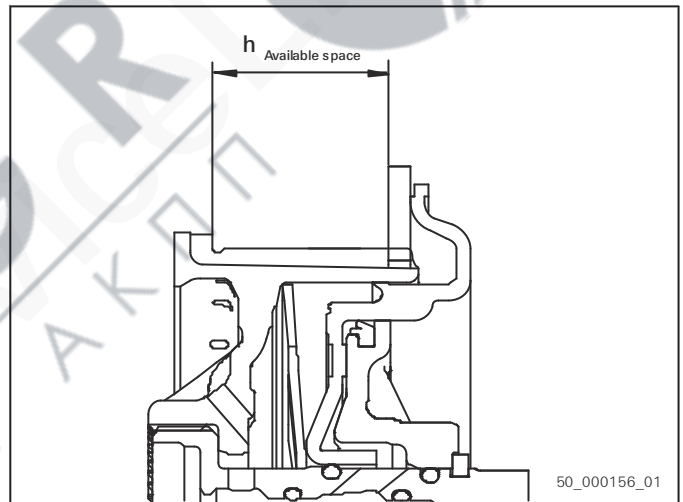

Fig. 101

⁴⁾ Height of available space

Formulas for calculating the running clearance

17. $h_{\text{Running clearance}} = h_{\text{Available space}} - h_{\text{Multidisks}}$

Exemplary calculation:

$$h_{\text{Running clearance}} = 28.50 \text{ mm} - 26.31 \text{ mm}$$

$$h_{\text{Running clearance}} = 2.19 \text{ mm}$$

18. Running clearance tolerance of clutch C
1.90 mm - 2.40 mm

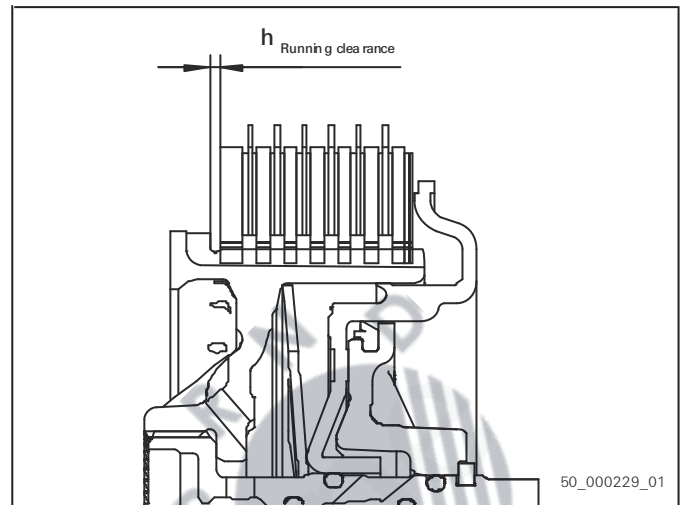

Fig. 102

- With 2.19 mm, the running clearance is O.K. and is within the permissible tolerance range.
- If value is outside of the tolerance range, use end disk of different thickness and remeasure.

10.3 Setting running clearance of clutch E

Special tools:

- 5P01.001.330 Measuring device
- 5P01.001.458 Test device
- 5P01.000.329 Test device
- 5P70.000.130 Height measuring device

i Composition of multidisk package in this example:

- one wave spring
- five inner clutch disks
- five lined clutch disks
- one end disk

The running clearance is set by using the end disk (71.060).

NOTICE

The composition of the multidisk package depends on the parts list [BoM] and may vary. The composition of the multidisk package affects the setting.

⇒ Observe valid setting specification. The setting specifications are available for download from the ZF-ServiceLine.

Assembling measuring equipment

1. Assemble 5P01.001.330 [Measuring device], 5P01.001.458 [Test device] and 5P01.000.329 [Test device].

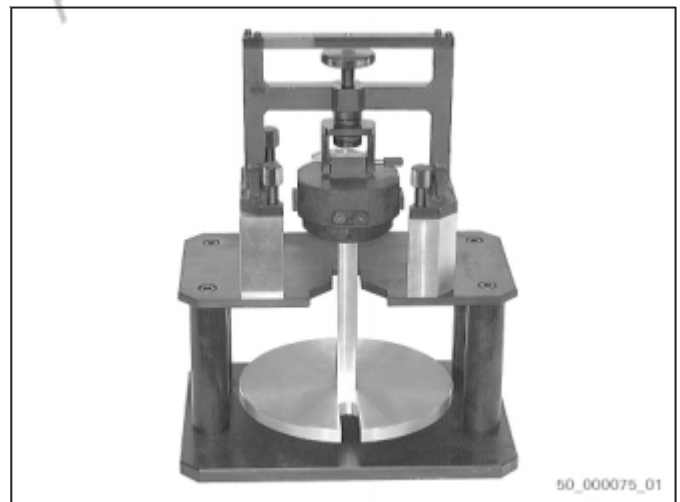

Fig. 103

Determine dimension $h_{\text{Multidisks}}^{5)}$

2. Center multidisk package.

3. **NOTICE**

Measurement results might be falsified.

⇒ Measure multidisk package without end disk.

Place multidisk package into center of measuring equipment.

4. Set specified preload force.
 $F = 200 \text{ N} \pm 5 \text{ N}$

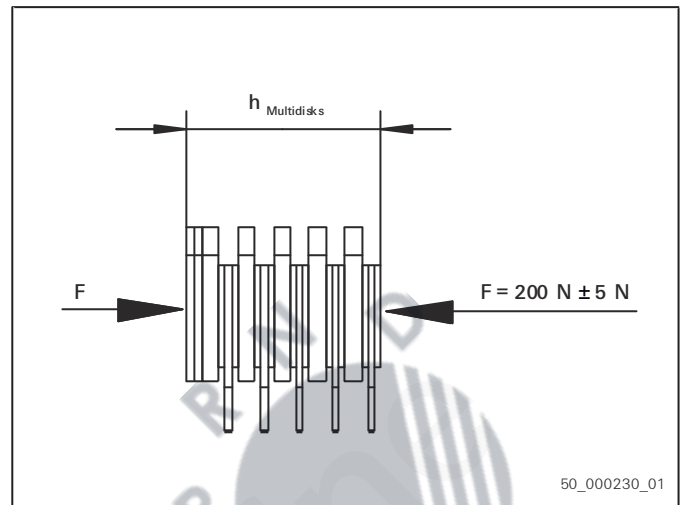

Fig. 104

5. Put measuring bar with dial gage on pressure plate of measuring device.

6. Put measuring stylus on base plate.

7. Reset dial gage.

8. Measure from base plate to multidisk package.

9. Repeat measurement at three spots.

10. Calculate mean value of $h_{\text{Multidisks}}$: 21.67 mm

Determine dimension $h_{\text{Available space}}^{6)}$

11. Assemble cylinder E, piston, disk spring, supporting ring and end disk and secure with old round wire ring.

12. Put measuring stylus of 5P70.000.130 [Height measuring device] on surface of plate multidisks.

13. Reset 5P70.000.130 [Height measuring device].

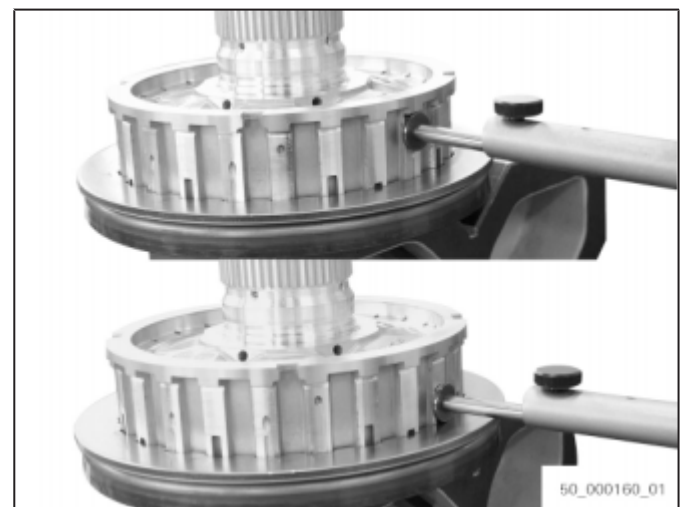

Fig. 105

5) Overall height of multidisk package

6) Height of available space

Testing, Measuring, Adjusting

14. Measure from surface of plate multidisks to upper edge of end disk.
15. Repeat measurement at three spots.
16. Calculate mean value of $h_{\text{Available space}}$:
23.75 mm

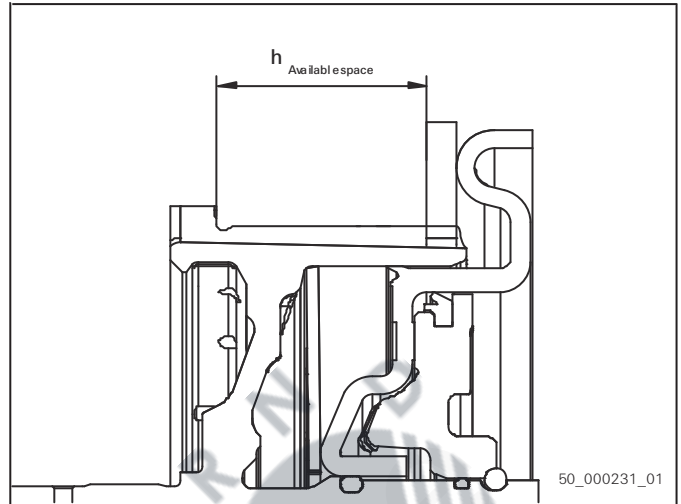

Fig. 106

Formulas for calculating the running clearance

17. $h_{\text{Running clearance}} = h_{\text{Available space}} - h_{\text{Multidisks}}$
 Exemplary calculation:
 $h_{\text{Running clearance}} = 23.75 \text{ mm} - 21.67 \text{ mm}$
 $h_{\text{Running clearance}} = 2.08 \text{ mm}$
18. Running clearance tolerance of clutch E
1.56 mm - 2.05 mm
19. Running clearance is outside of tolerance range.
Choose different end disk: 3.6 mm
Remeasure multidisk package.

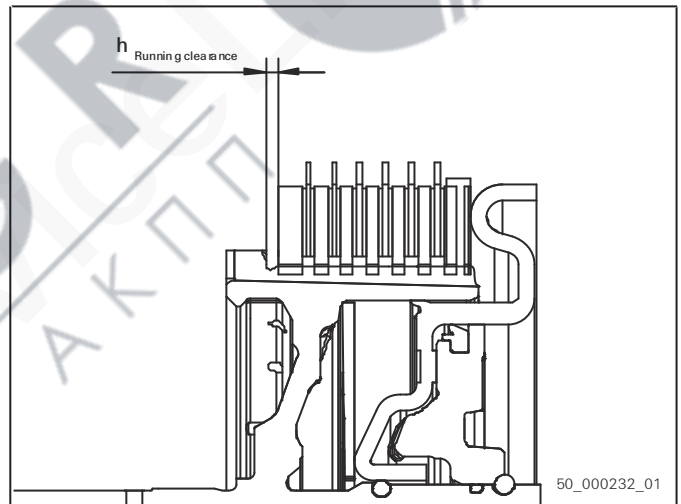

Fig. 107

New calculation

20. Exemplary calculation:
 New measured value $h_{\text{Multidisks}} = 21.97 \text{ mm}$
 $h_{\text{Running clearance}} = 23.75 \text{ mm} - 21.97 \text{ mm}$
 $h_{\text{Running clearance}} = 1.78 \text{ mm}$

- With 1.78 mm, the running clearance is O.K. and is within the permissible tolerance range.
- If value is outside of the tolerance range, use end disk of different thickness and remeasure.

10.4 Setting running clearance of brake A

Special tools:

- 5P01.001.330 Measuring device
- 5P01.001.458 Test device
- 5P01.000.329 Test device
- 5P33.000.009 / 5P74.001.051 Measuring bar with dial gage

i Composition of multidisk package in this example:

- one wave spring
- five outer clutch disks
- five separation springs
- five lined clutch disks
- one end disk

The running clearance is set by using the snap ring (70.160).

NOTICE

The composition of the multidisk package depends on the parts list [BoM] and may vary. Depending on the transmission version, composition with or without multidisk separation is possible. The composition of the multidisk package affects the setting.

⇒ Observe valid setting specification. The setting specifications are available for download from the ZF-ServiceLine.

Assembling measuring equipment

1. Assemble 5P01.001.330 [Measuring device], 5P01.001.458 [Test device] and 5P01.000.329 [Test device].

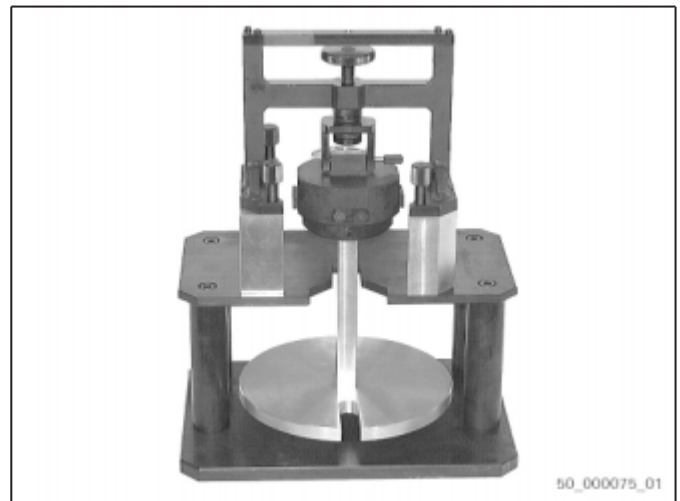

Fig. 108

Calculate dimension $h_{\text{Multidisks}}^{7)}$

- Center multidisk package.
- Place multidisk package into center of measuring equipment.
- Set specified preload force.
 $F = 400 \text{ N} \pm 5 \text{ N}$

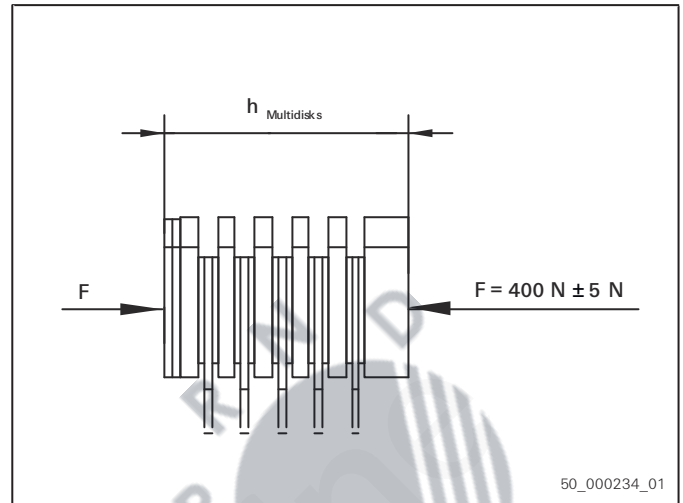



Fig. 109

- Put measuring bar with dial gage on pressure plate of measuring device.
- Put measuring stylus on base plate.
- Reset dial gage.
-  Do not measure multidisk package on studs.

Measure from base plate to multidisk package.

- Repeat measurement at three spots.
- Calculate mean value of $h_{\text{Multidisks}}$: 20.61 mm



Fig. 110

7) Overall height of multidisk package

Determine dimension $h_{\text{Cylinder/Snap ring groove}}$ ⁸⁾

11. Put 5P33.000.009 / 5P74.001.051 [Measuring bar with dial gage] on cylinder A.
12. Reset dial gage.



Fig. 111

13. Measure from cylinder A to upper edge of snap ring groove.
14. Repeat measurement at three spots.
15. Calculate mean value of $h_{\text{Piston/Snap ring groove}}$: 22.80 mm



Fig. 112

⁸⁾ Dimension of height of cylinder to snap ring groove

Formulas for calculating the running clearance

16. $h_{\text{Available space}} = h_{\text{Cylinder/Snap ring groove}} + h_{\text{Measuring stylus}}$
 Exemplary calculation:
 $h_{\text{Available space}} = 22.80 \text{ mm} + 2.00 \text{ mm}$
 $h_{\text{Available space}} = 24.80 \text{ mm}$

17. $h_{\text{Running clearance}} = h_{\text{Available space}} - h_{\text{Multidisks}} - h_{\text{Snap ring}}$
 Exemplary calculation:
 $h_{\text{Running clearance}} = 24.80 \text{ mm} - 20.61 \text{ mm} - 2.2 \text{ mm}$
 $h_{\text{Running clearance}} = 1.99 \text{ mm}$

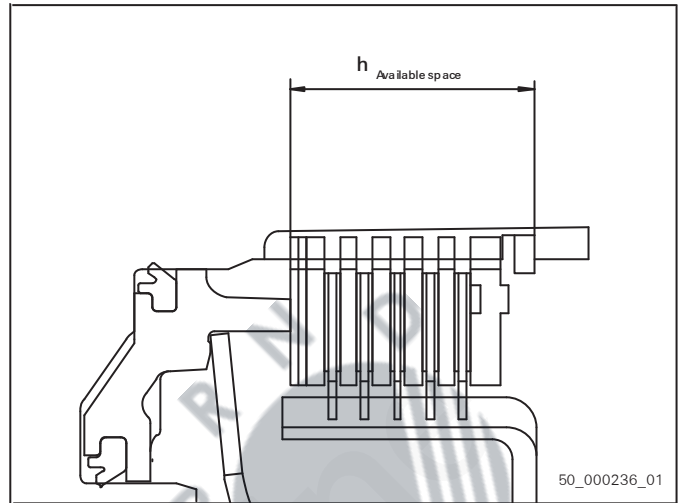

Fig. 11 3

18. Running clearance tolerance of brake A with/without separation 1.66 mm - 1.95 mm

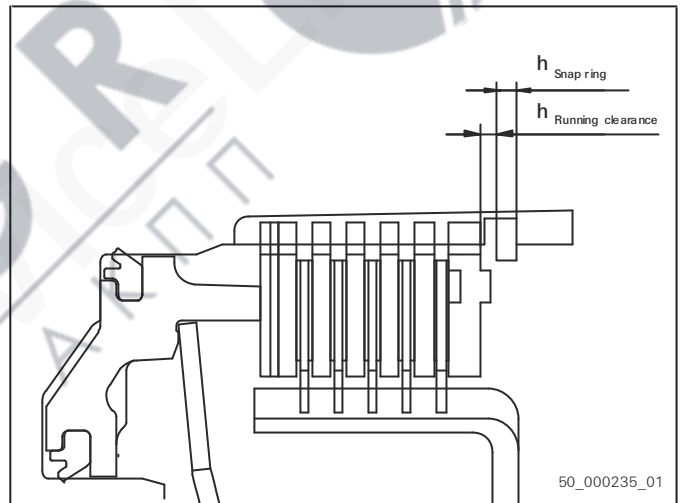

Fig. 11 4

- With 1.99 mm, the running clearance is O.K. and is within the permissible tolerance range.
- If value is outside of the tolerance range, use snap ring of different thickness and remeasure.

10.5 Setting running clearance of brake B

Special tools:

- 5P01.001.330 Measuring device
- 5P01.001.458 Test device
- 5P01.000.329 Test device
- 5P33.000.009 / 5P74.001.051 Measuring bar with dial gage

i Composition of multidisk package in this example:

- one wave spring
- five outer clutch disks
- five separation springs
- five lined clutch disks
- one end disk

The running clearance is set by using the end disk (72.040).

NOTICE

The composition of the multidisk package depends on the parts list [BoM] and may vary. Depending on the transmission version, composition with or without separation is possible. The composition of the multidisk package affects the setting.

⇒ Observe valid setting specification. The setting specifications are available for download from the ZF-ServiceLine.

Assembling measuring equipment

1. Assemble 5P01.001.330 [Measuring device], 5P01.001.458 [Test device] and 5P01.000.329 [Test device].



Fig. 11 5

Testing, Measuring, Adjusting

Determine dimension $h_{\text{Multidisks}}^9)$

2. Center multidisk package.
3. Place multidisk package into center of measuring equipment.
4. Set specified preload force.
 $F = 500 \text{ N} \pm 5 \text{ N}$

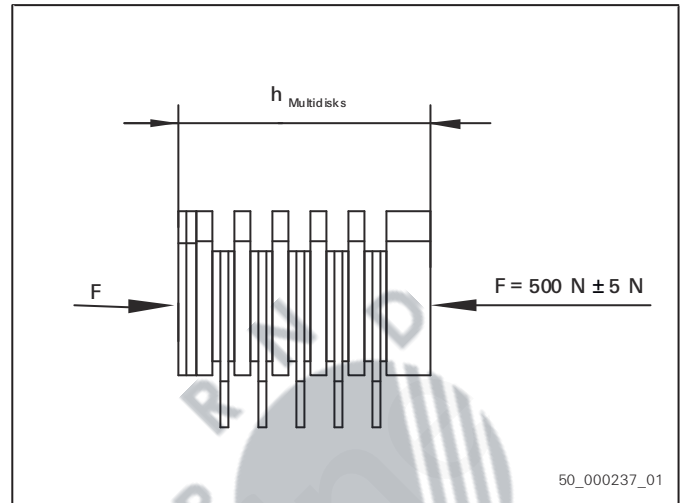

Fig. 116

5. Put measuring bar with dial gage on pressure plate of measuring device.
6. Put measuring stylus on base plate.
7. Reset dial gage.
8. Measure from base plate to multidisk package.
9. Repeat measurement at three spots.
10. Calculate mean value of $h_{\text{Multidisks}}$: 26.75 mm

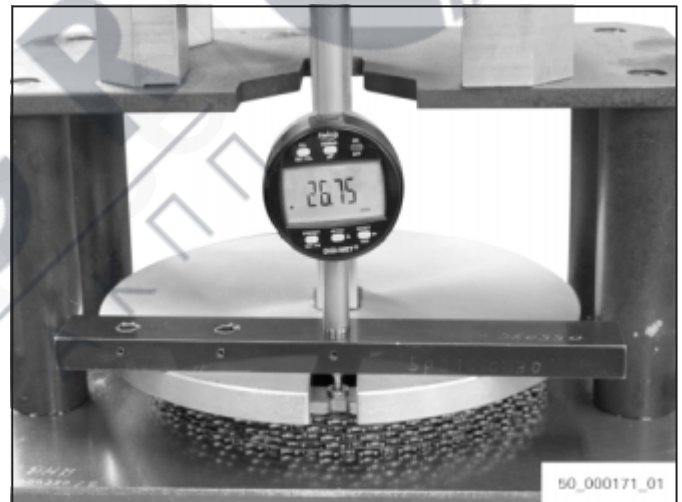



Fig. 117

⁹⁾ Overall height of multidisk package

Determine dimension $h_{\text{Available space}}$ ¹⁰⁾

11. Put 5P33.000.009 / 5P74.001.051 [Measuring bar with dial gage] on piston B.

12. Reset dial gage.

13.  Pistons must be free from oil and be firmly attached.

Put measuring bar with dial gage on piston B and determine depth dimension down to the intermediate plate's plane face.

14. Repeat measurement at three spots.

15. Calculate mean value of $h_{\text{Available space}}$:
34.35 mm



Fig. 118

Fixed dimension

16. Observe specified fixed dimension.

- $h_{\text{Fixed dimension}}$ **with separation:**
63.0 + 0.1 mm
- $h_{\text{Fixed dimension}}$ **without separation:**
61.8 + 0.1 mm

Formulas for calculating the running clearance

17. $h_{\text{Running clearance}} = h_{\text{Fixed dimension}} - h_{\text{Available space}} - h_{\text{Multidisks}}$

Exemplary calculation:

$$h_{\text{Running clearance}} = 63.10 \text{ mm} - 34.35 \text{ mm} - 26.75 \text{ mm}$$

$$h_{\text{Running clearance}} = 2.00 \text{ mm}$$

18. Running clearance tolerance of brake B with/without separation 1.71 mm - 2.12 mm

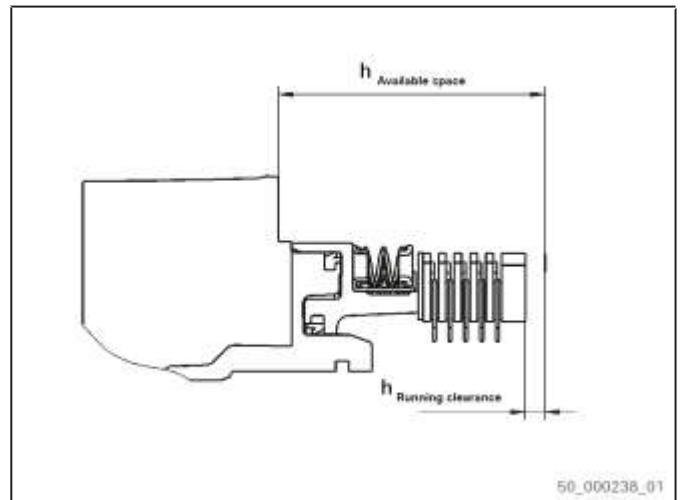

Fig. 119

→ With 2.00 mm, the running clearance is O.K. and is within the permissible tolerance range.

→ If value is outside of the tolerance range, use end disk of different thickness and remeasure.

¹⁰⁾ Dimension of height of available space

10.6 Setting backlash

Special tools:

- 5P01.000.347 Measurement stand

NOTICE

The backlash must be checked and set, if required.

⇒ Observe valid setting specification. The setting specifications are available for download from the ZF-ServiceLine.

1. Preload oil supply crosswise using four screws with 5.0 Nm.
2. Place transmission with input end facing downwards.



Fig. 120

3.

NOTICE

Take measurement without snap ring.

⇒ Before taking measurement, remove snap ring from output shaft, if required.

Insert 5P01.000.347 [Measurement stand] into suitable transmission housing bore.

4. Put dial gage on output shaft.
5. Press down output shaft and reset dial gage.

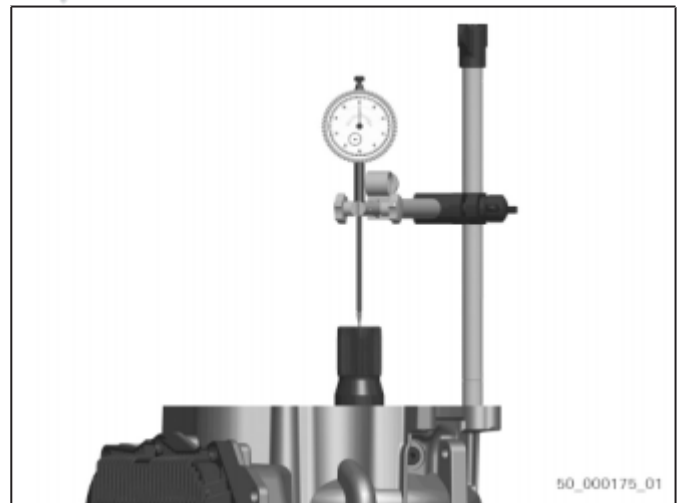



Fig. 121

6. Pull up output shaft and read value:
Backlash = 0.26 mm

7.  The axial backlash is set with an undefined measuring force. To compensate the deviation caused by this, the tolerance is reduced by 0.10 mm starting from the upper tolerance limit.

Set point of defined measuring force:
0.11 mm - 0.42 mm

Set point of undefined measuring force:
0.11 mm - 0.32 mm

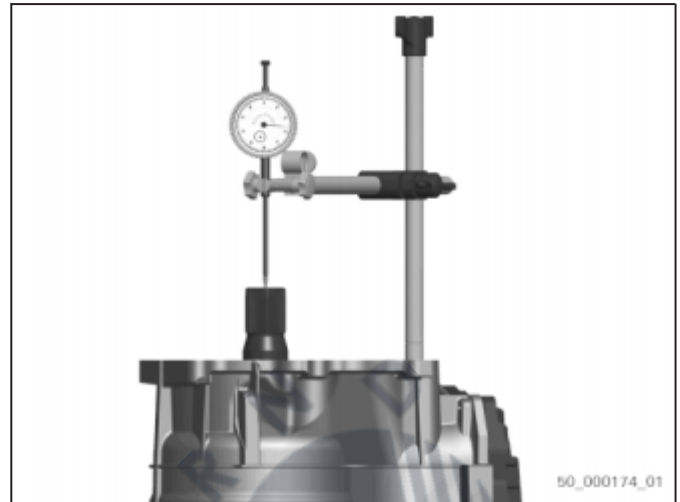

Fig. 122

Backlash tolerance 0.11 mm - 0.32 mm

8. With 0.26 mm, the backlash is O.K. and is within the permissible tolerance range.
9. Remove measurement stand.
10. Place transmission with input end facing upwards.
11. Unscrew four screws from oil supply.

10.7 Directives on screw connections

10.7.1 Oil supply

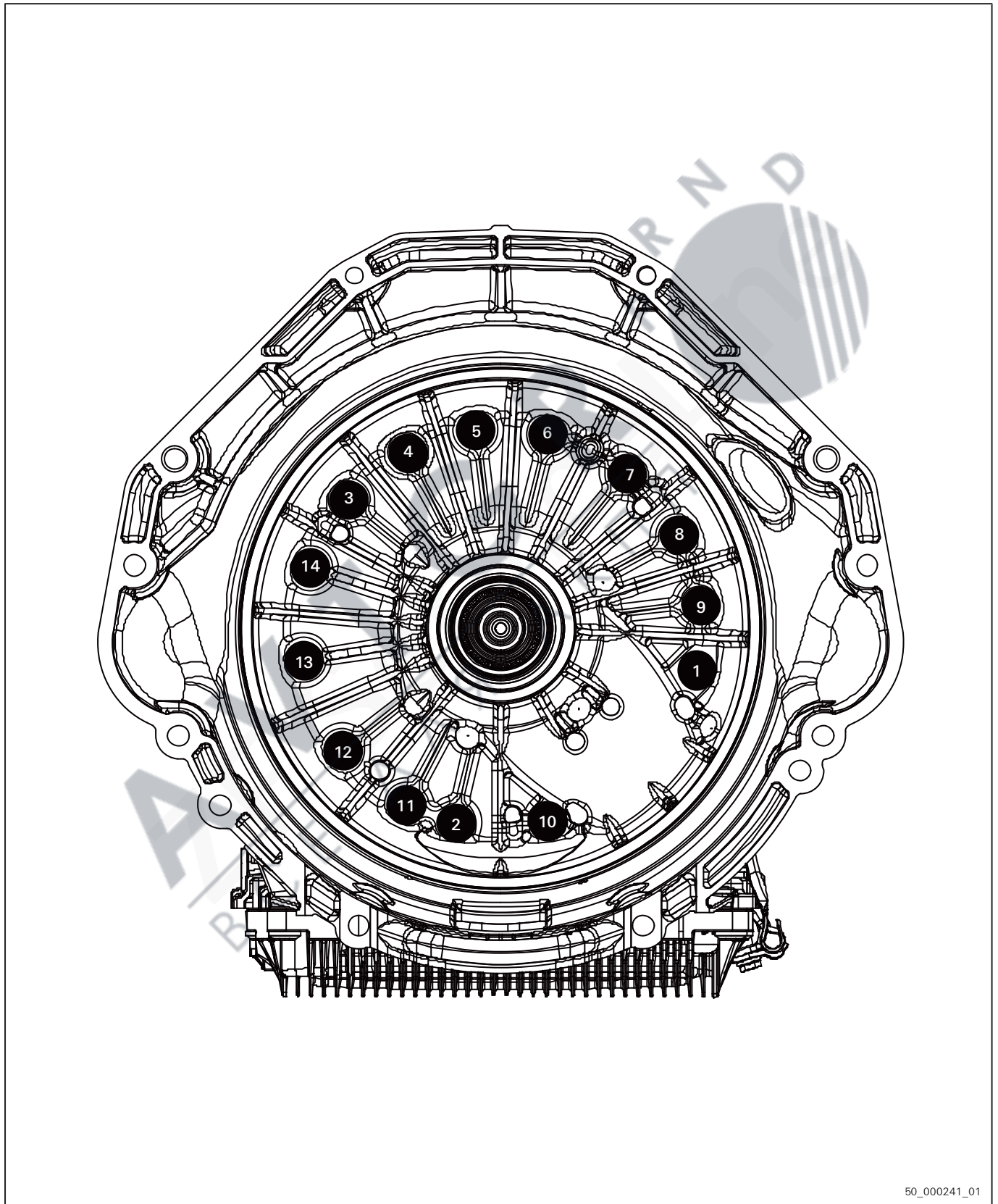

50_000241_01

Fig. 123 Specification no. 1087.700.149

10.7.2 Mechatronic and hydraulic impulse oil storage

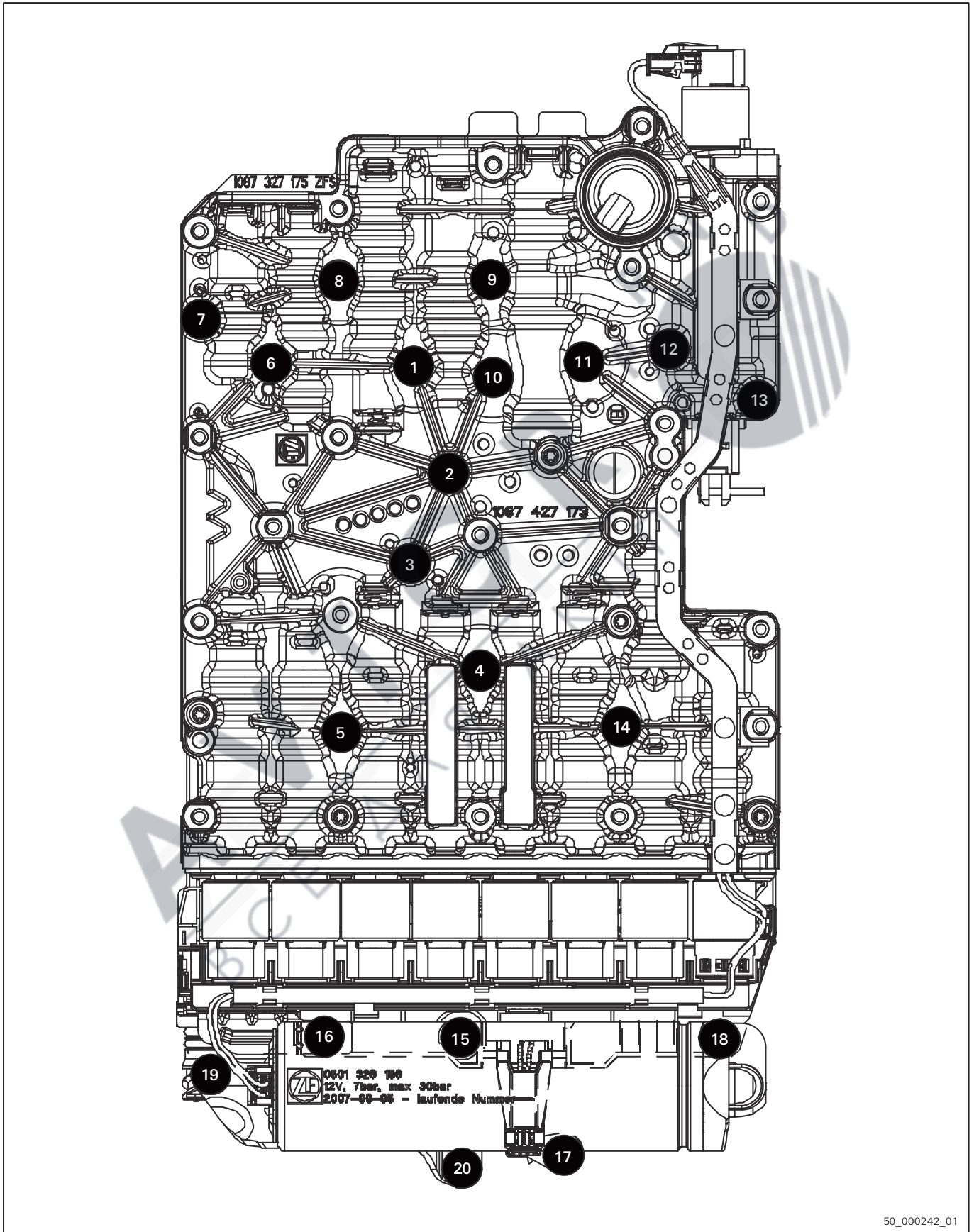
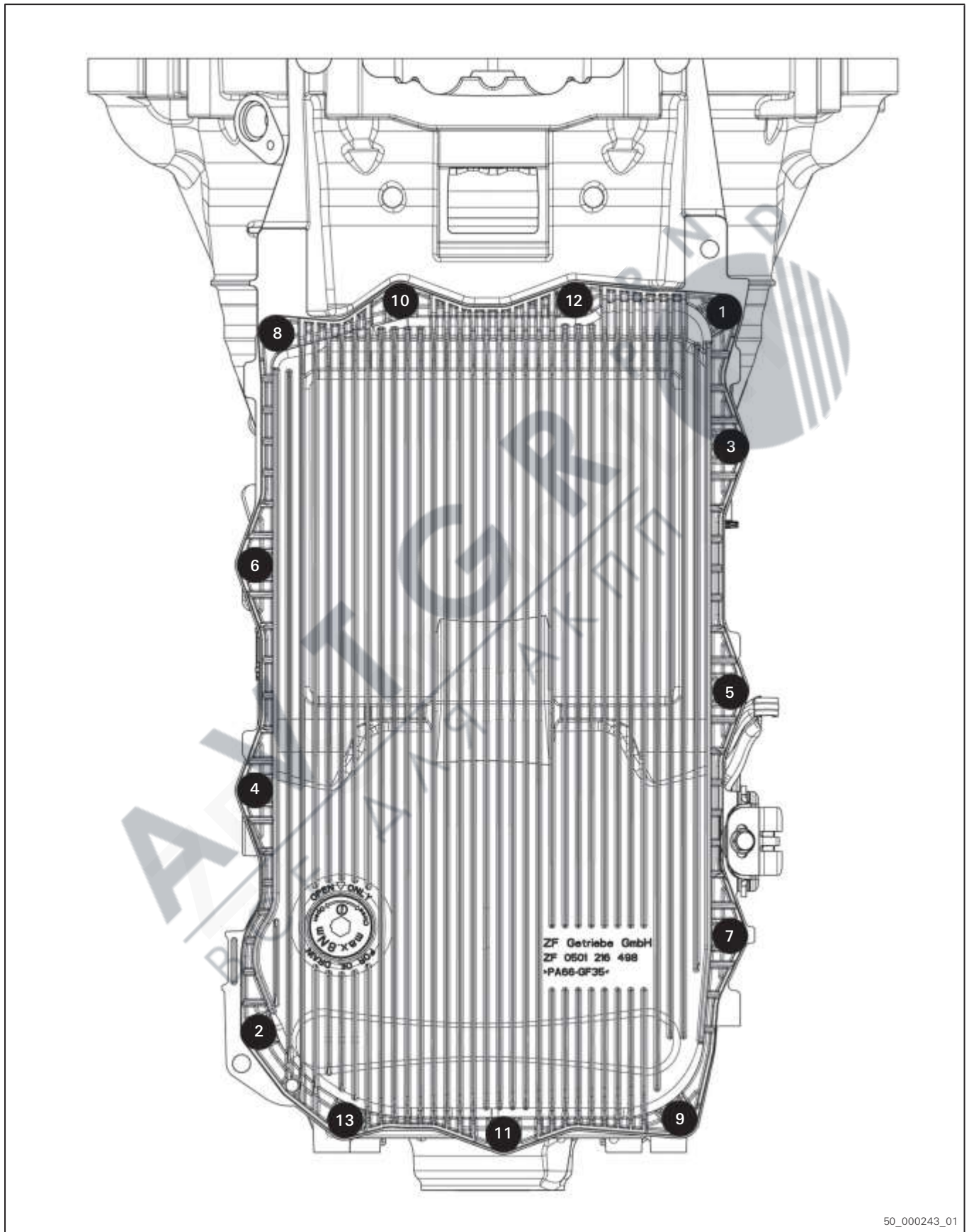

Fig. 124 Specification no. 1087.700.079

10.7.3 Oil pan



50_000243_01

Fig. 125 Specification no. 1087.700.136

10.7.4 Intermediate plate

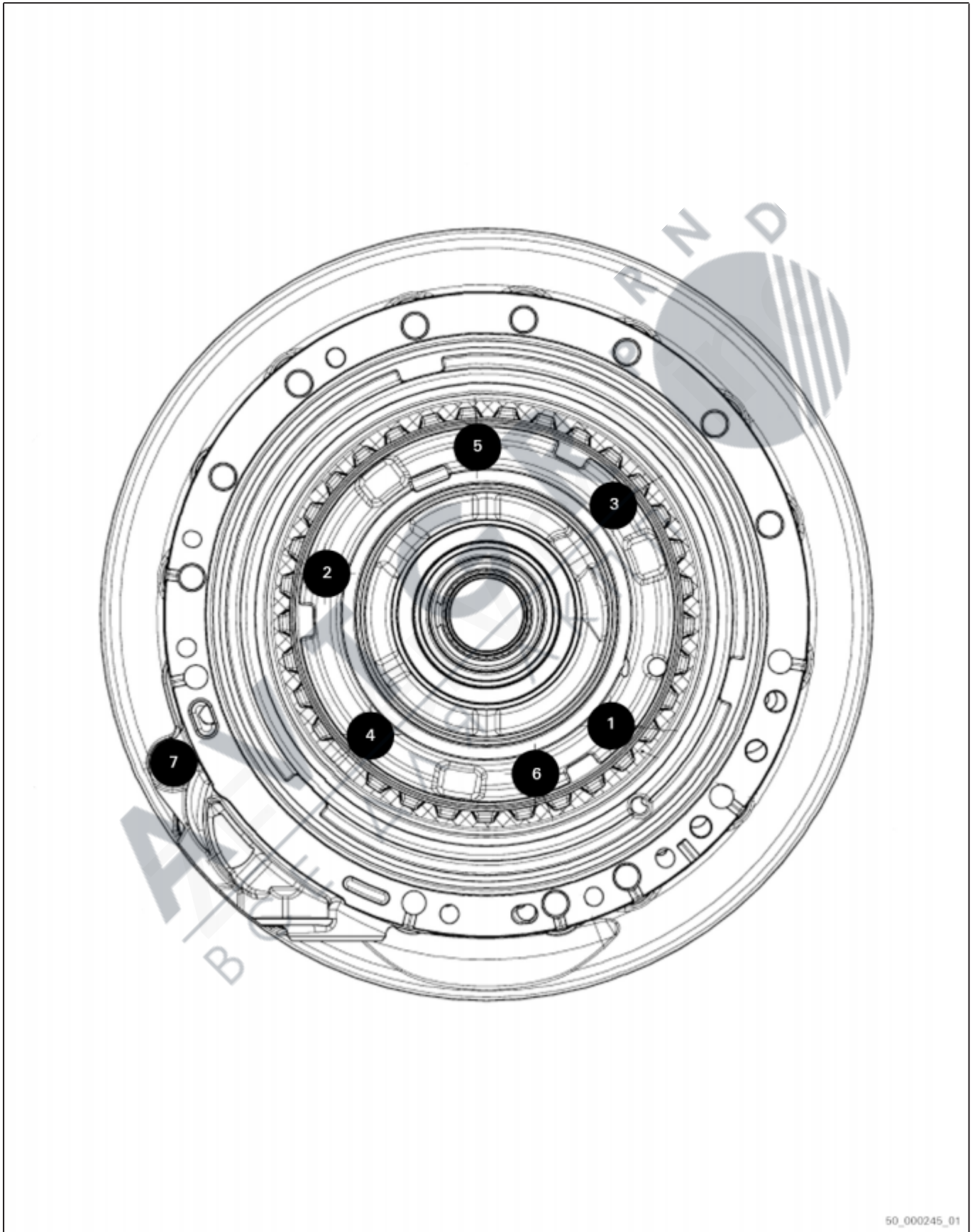

Fig. 126 Specification no. 1102.700.067

10.7.5 Guiding plate

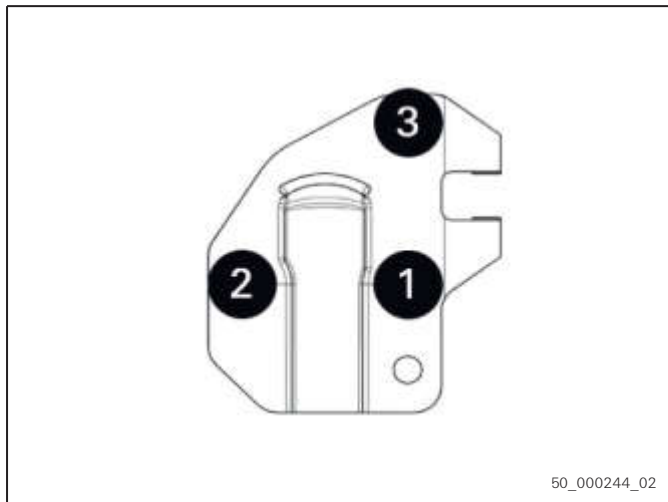

Fig. 127 Specification no. 1087.700.205

Sequence	Screw	Tightening torque
1	3	Turn in, 2 – 4 turns
2	1 – 3	10.0 Nm \pm 10%

Tab. 1 Tightening sequence

11 Assembly

11.1 Fitting output

Special tools:

- 5T66.000.286 Assembly bracket
- 5X54.909.282 Press-in device
- 5X54.909.281 Press-in device

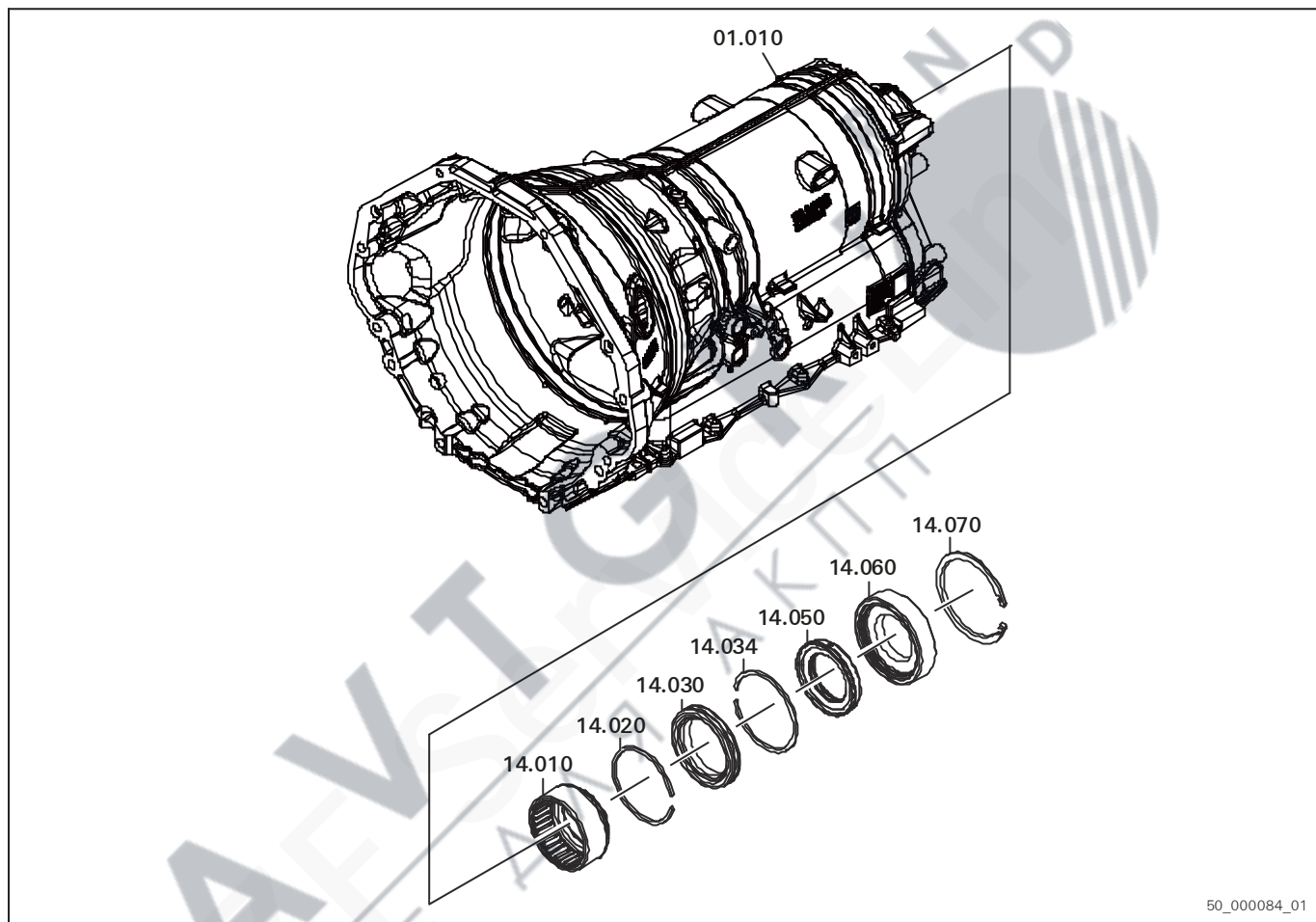

Fig. 128 14 - Output

1. Get components ready.

2.

⚠ WARNING

Risk of injury due to falling parts.

Death or serious injury possible.

- ⇒ Secure parts against falling down.
- ⇒ Do not stand beneath a suspended load.
- ⇒ Do not work on a suspended load.

Fit transmission housing (01.010) into assembly trolley or workbench bracket using 5T66.000.286 [Assembly bracket].

3. Place transmission with output end facing upwards.
4. Put drawn cup needle roller bearing (14.010) on 5X54.909.282 [Press-in device] and install in transmission housing on output end.
5. Secure drawn cup needle roller bearing with new snap ring (14.020).

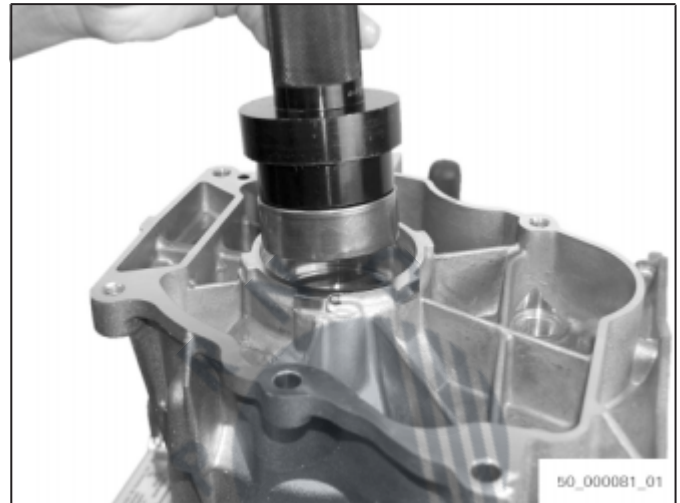

Fig. 129

6. Put new sealing sleeve (14.030) on 5X54.909.281 [Press-in device] and install in transmission housing.
7. Secure sealing sleeve with new snap ring (14.034).



Fig. 130

8. Assemble axial needle bearing (14.050) and supporting ring (14.060).
9. Insert supporting ring into transmission housing.
10. Secure supporting ring with new snap ring (14.070).



Fig. 131

11.2 Assembling parking lock

Special tools:

- 5X46.002.561 Press-in mandrel
- 5X46.001.368 Press-in device

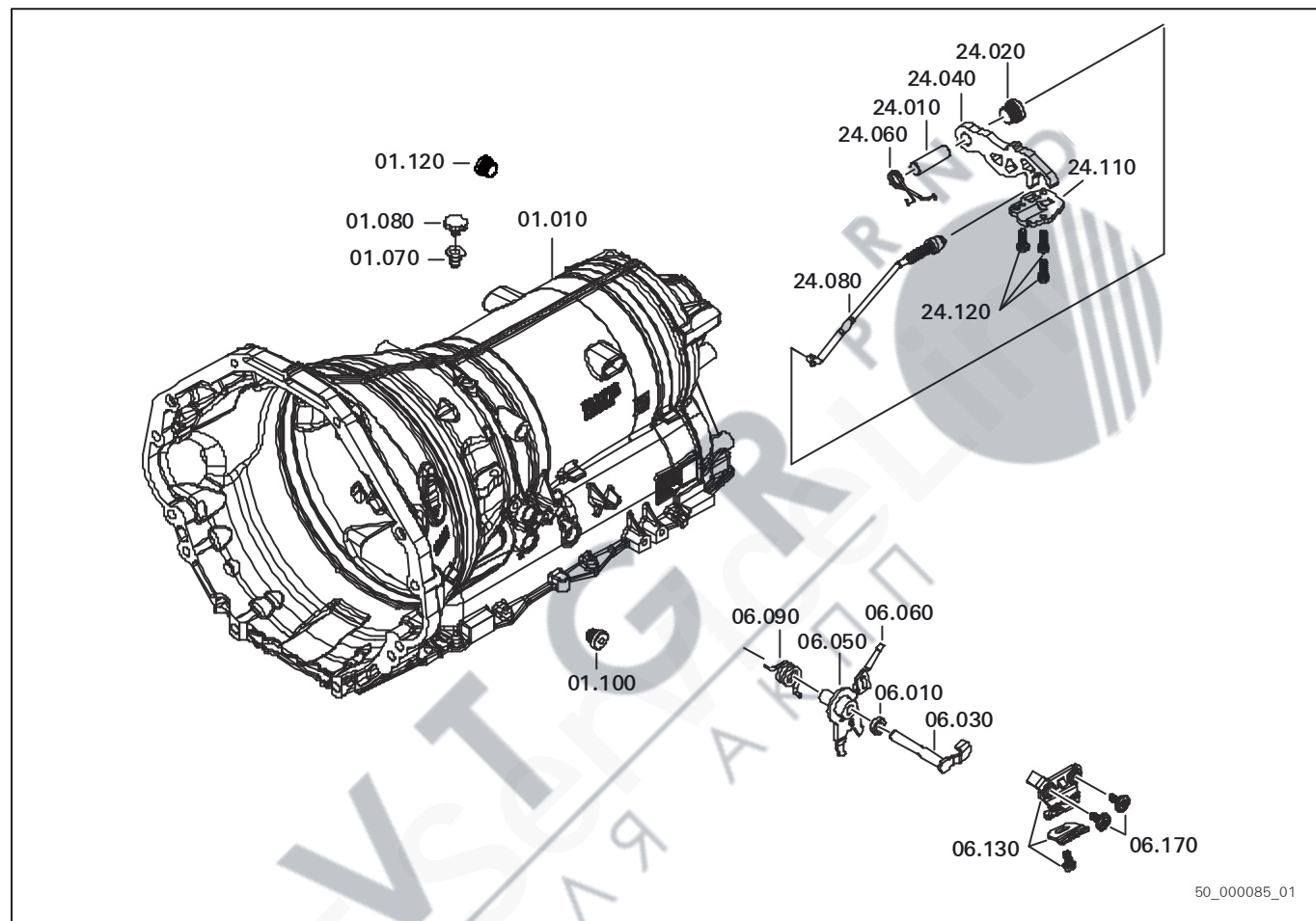

Fig. 132 01 - Transmission housing, 06 - Shift system, 24 - Parking lock

1. Get components ready.

2.

NOTICE

Property damage due to leakage possible.

⇒ Use 5X46.002.561 [Press-in mandrel].

Place transmission with oil pan end facing upwards.

3. Put shaft sealing ring of selector shaft (06.010) on 5X46.002.561 [Press-in mandrel] and install in transmission housing.

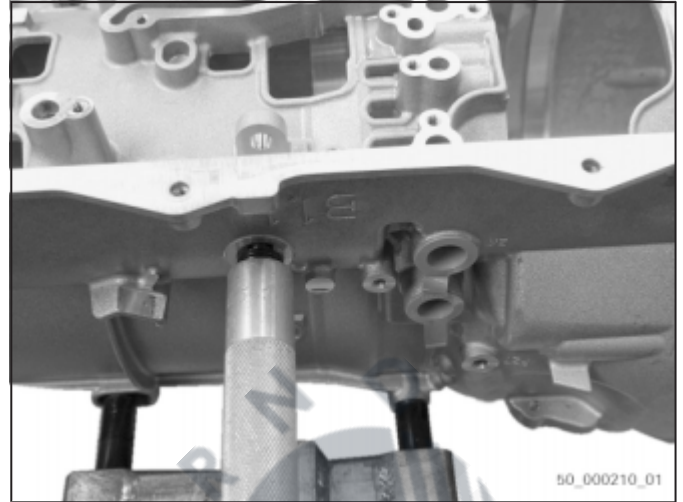

Fig. 133

4. Put spring (06.090) on parking disk.

5. Fit connecting rod (24.080) in parking disk (06.050) and rotate.

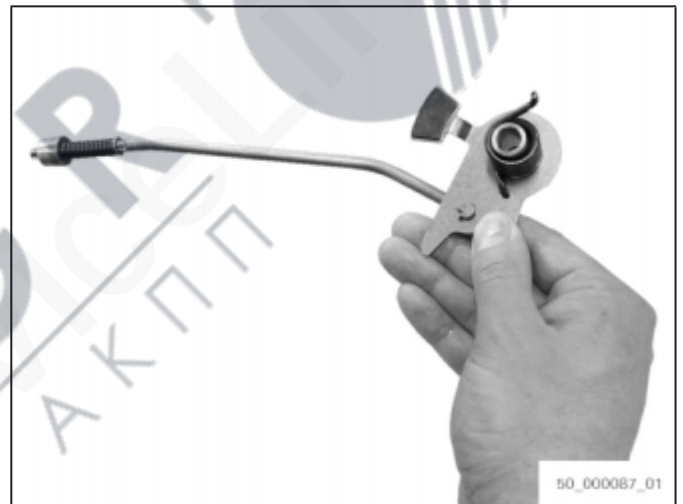



Fig. 134

6.  Selector shaft bore must be in line with catch disk bore.

Insert parking disk with connecting rod into transmission housing and push selector shaft (06.030) through catch disk.

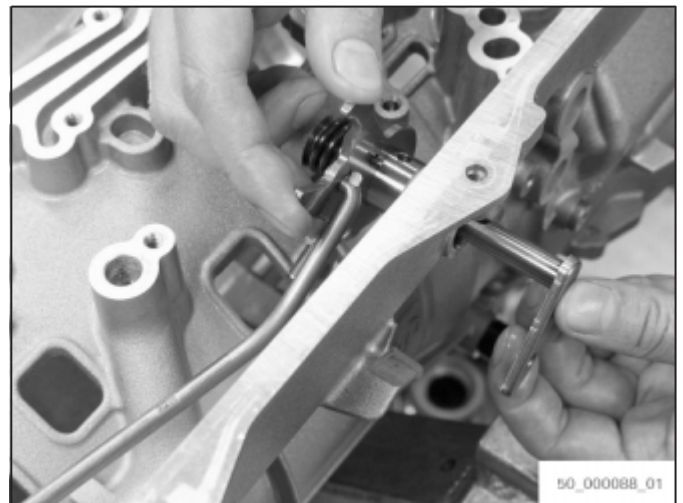

Fig. 135

7. Insert clamping sleeve with taper facing forward into 5X46.001.368 [Press-in device].



Fig. 136

8. Drive in new clamping sleeve (06.060) using 5X46.001.368 [Press-in device] until firmly home.



Fig. 137

9. Insert ratchet (24.040) with spiral spring (24.060) into transmission housing. Fix ratchet and spiral spring with parking lock bolt (24.010).

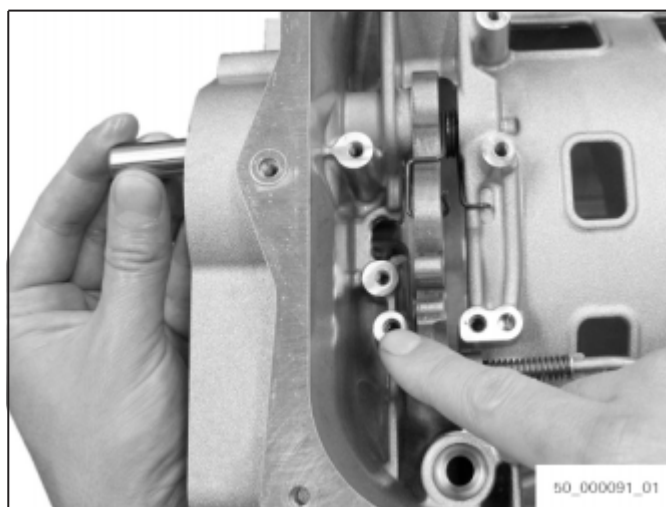

Fig. 138

10. Screw in new screw plug of parking lock bolt (24.020) into transmission housing.
Tightening torque: **36 Nm (± 3.5 Nm)**

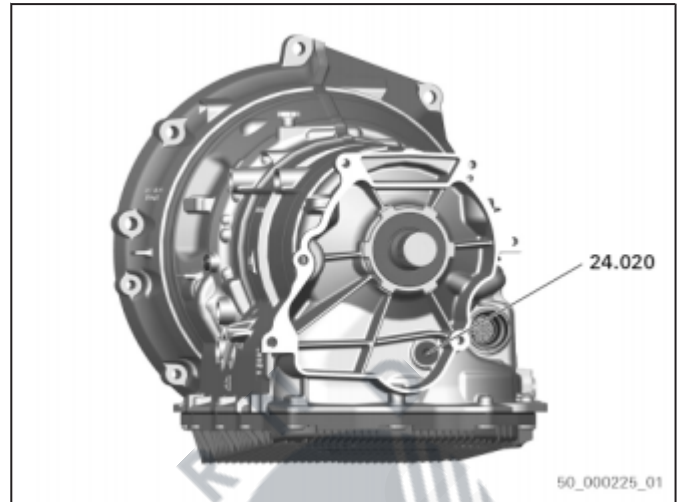



Fig. 139 Screw plug of parking lock bolt

11.  Observe tightening torque and screw connection directive (refer to section Guiding plate, page 92).

NOTICE

The screws are coated with an adhesive for screw retention.

⇒ Use new screws.

Press down ratchet and put on connecting rod.



Fig. 140

12. Install guiding plate (24.110).
13. Screw in three new hexalobular driving screws (24.120) into guiding plate.
Tightening torque: **10 Nm (± 1.0 Nm)**

After assembly, check parking lock for correct function.

If the parking lock can be engaged and disengaged without problems, the test is correct.

11.3 Assembling clutches

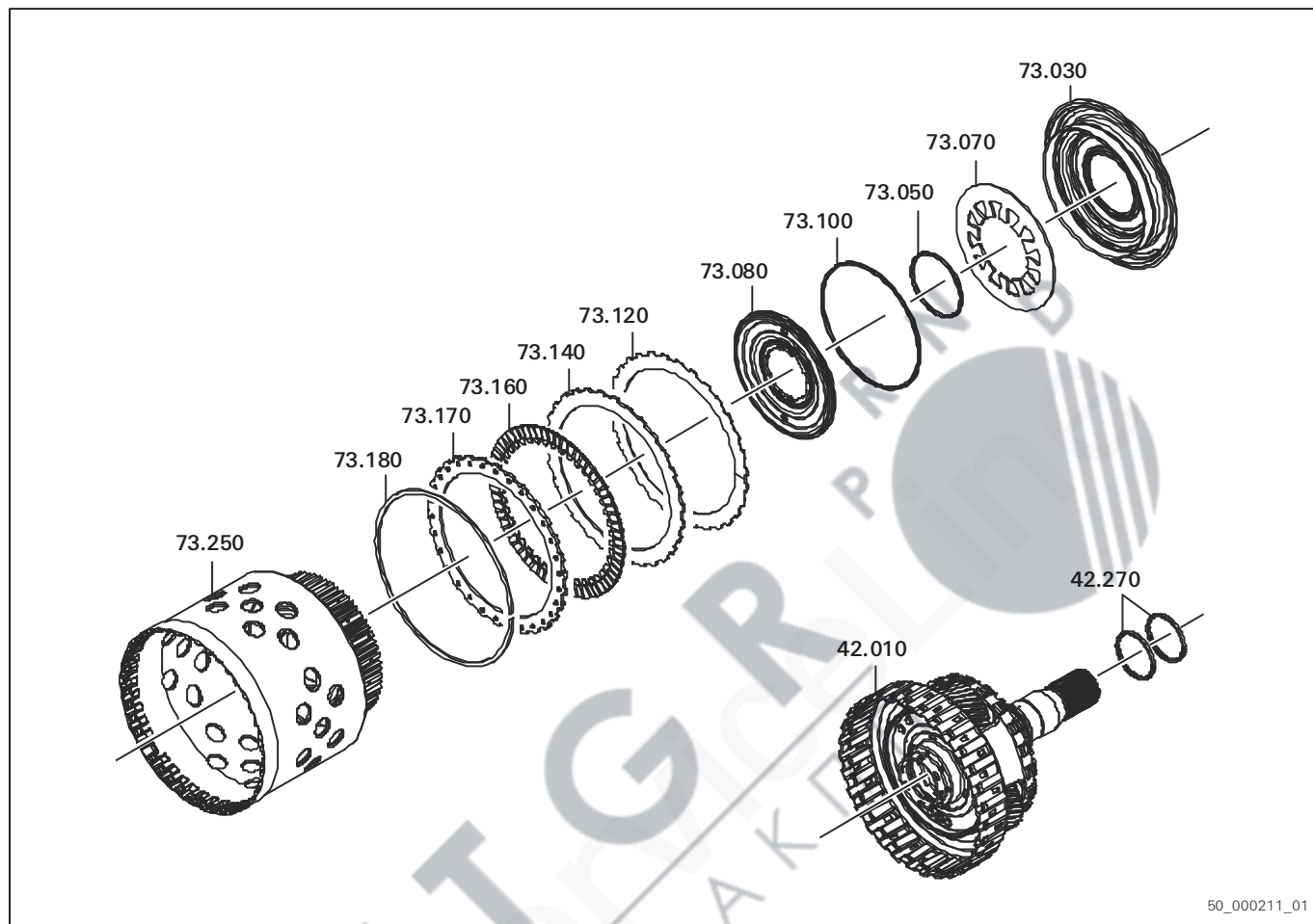

Fig. 141 42 - Planetary gearset 4, 73 - Clutch D

11.3.1 Assembling clutch D

Special tools:

- 5X46.004.264 Assembly fixture
- AA00.349.340 Assembly fixture

Assembly

1. Get components ready.
2. Put two new rectangular rings (42.270) on output shaft (42.010).



Fig. 142

3.  Sealing element cannot be replaced. In case of damage, replace complete component.

Insert output shaft in
5X46.004.264 [Assembly fixture].



Fig. 143

4. Put new O-ring (73.050) on piston D (73.030).
5. Press piston D into cylinder D.



Fig. 144

6. Insert disk spring (73.070).



Fig. 145

7. Put new O-ring (73.100) on baffle plate.

8. Fit baffle plate (73.080).



Fig. 146

9. Put AA00.349.340 [Assembly fixture] with both pins into the recesses of the baffle plate. Ensure correct position.



Fig. 147

10. Preload baffle plate in arbor press using AA00.349.340 [Assembly fixture].
11. Turn AA00.349.340 [Assembly fixture] counterclockwise until dog point is positioned between the two securing clips.



Fig. 148

12.  Observe running clearance setting of clutch D (refer to section Setting running clearance of clutch D, page 68).

Fit multi-disk package:

- Wave spring (73.120)
- Outer clutch disks (73.140) and lined clutch disks (73.160) in alternating way.
- End disk (73.170)

13. Secure end disk with snap ring (73.180).

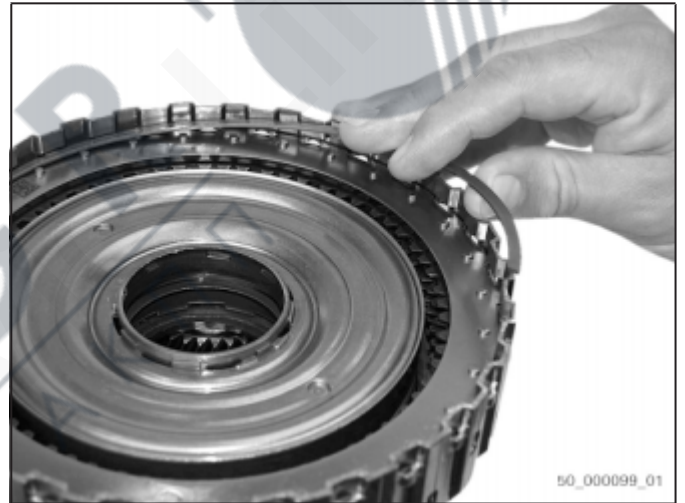

Fig. 149

11.3.2 Assembling clutch C

Special tools:

- AA00.533.332 Assembly fixture

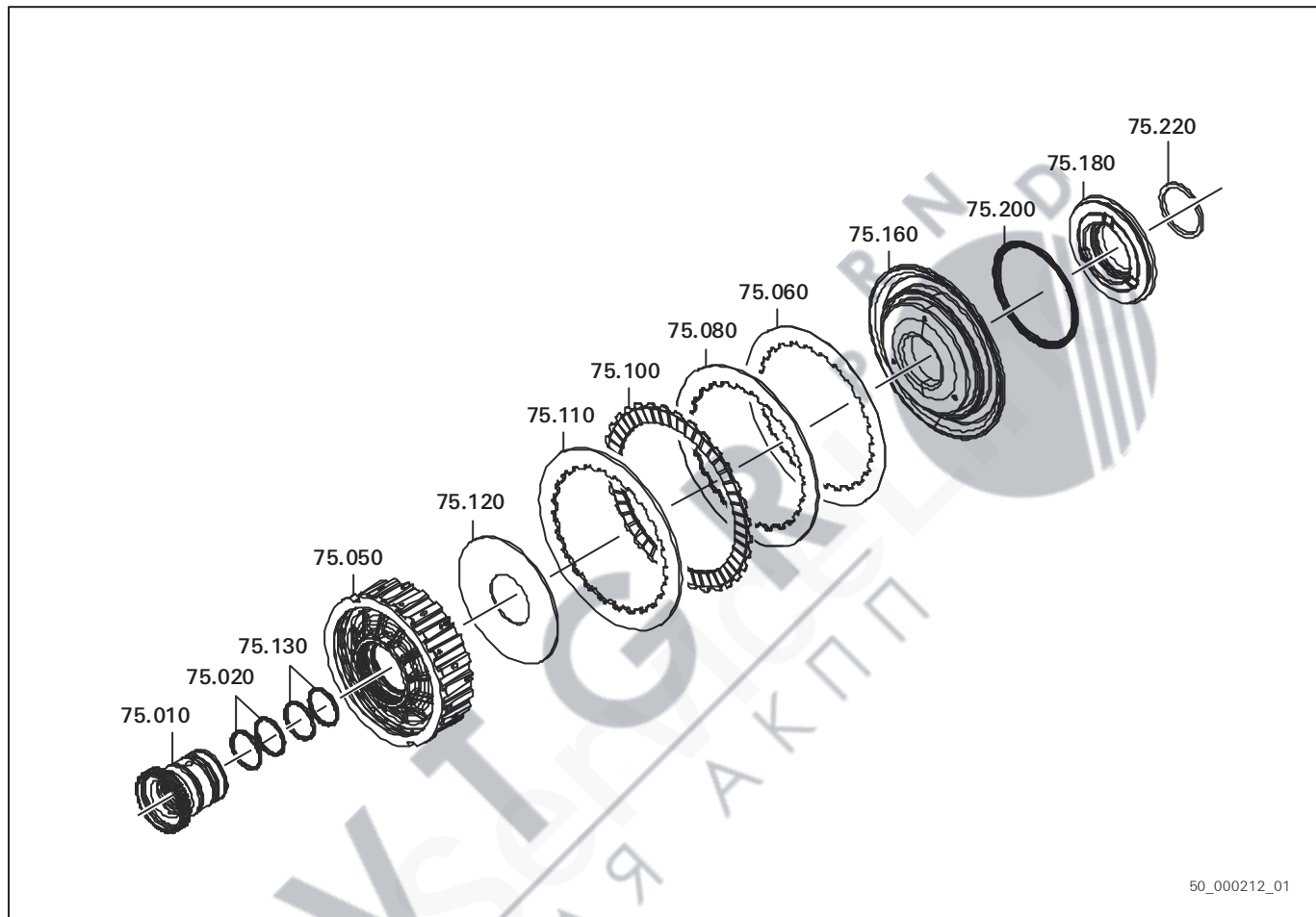

Fig. 150 75 - Clutch C

1. Get components ready.

Assembly

- Put on four new O-rings - 2 O-rings in hub (75.020) and 2 O-rings (75.130) on hub (75.010).
- Put cylinder C (75.050) over hub.
- Install disk spring (75.120) in cylinder C.

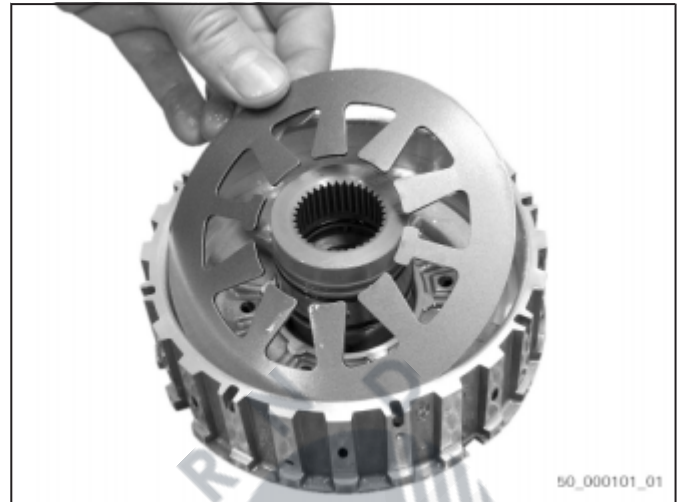



Fig. 151

-  Observe running clearance setting of clutch C (refer to section Setting running clearance of clutch C, page 72).

Fit multidisk package:

- End disk (75.110)
- Lined clutch disks (75.100) and inner clutch disks (75.080) in alternating way.
- Wave spring (75.060)



Fig. 152

-  Sealing element cannot be replaced. In case of damage, replace complete component.

Press piston C (75.160) on cylinder C.



Fig. 153

7. Put new lipped seal ring (75.200) on supporting ring.
8. Press supporting ring (75.180) into piston C.



Fig. 154

9. Press down clutch C in arbor press using AA00.533.332 [Assembly fixture] and secure with new snap ring (75.220).



Fig. 155

11.3.3 Assembling clutch E

Special tools:

- AA00.858.018 Assembly fixture

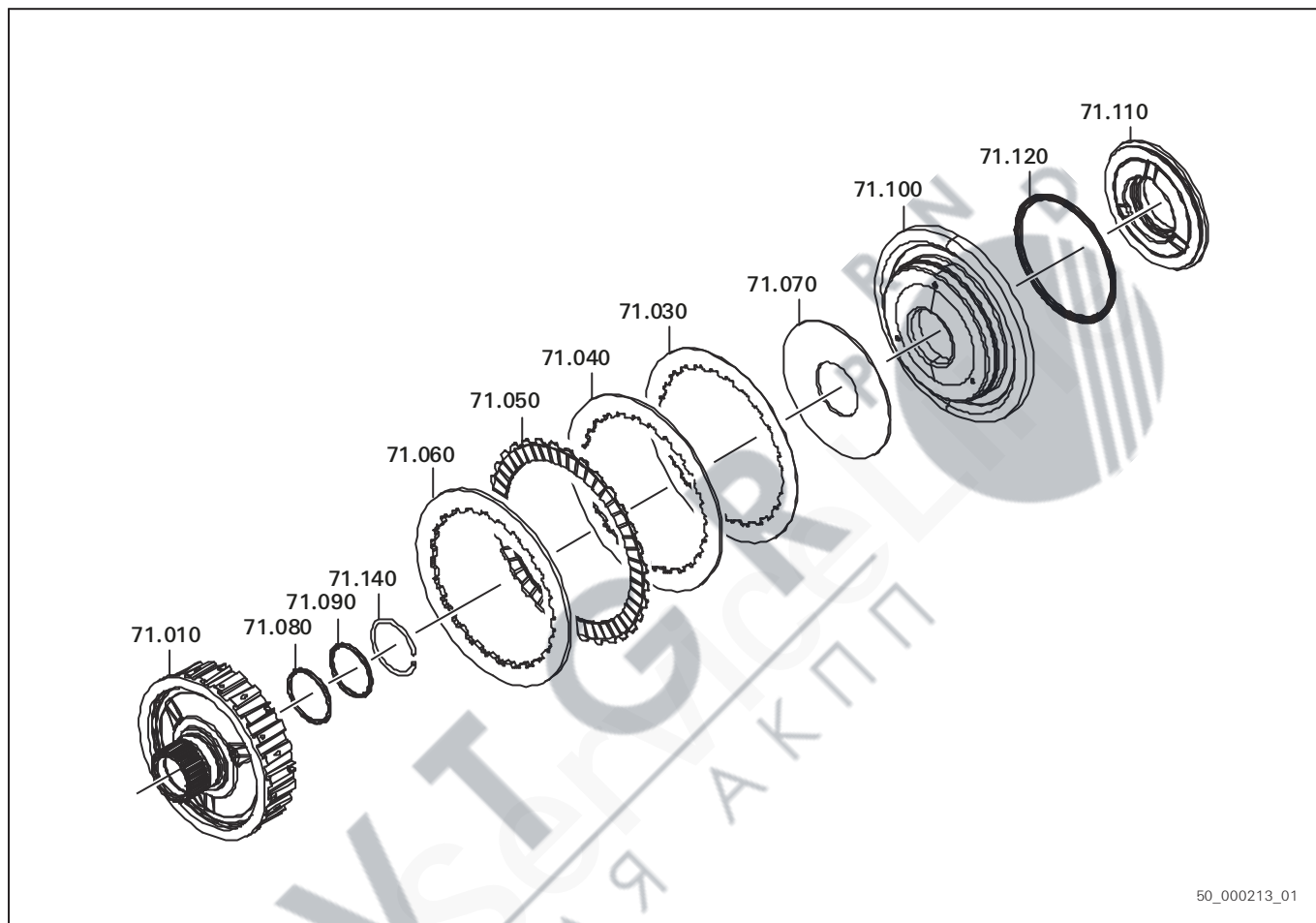

Fig. 156 71 - Clutch E

1. Get components ready.

2. Put two new O-rings (71.080) (71.090) on cylinder E (71.010).
3. Insert spring disk (71.070) into cylinder E.

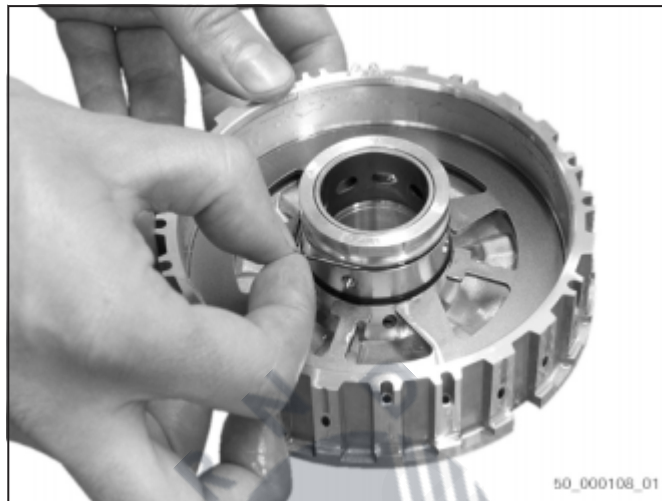



Fig. 157

4.  Observe running clearance setting of clutch E (refer to section Setting running clearance of clutch E, page 76).

Fit multi-disk package:

- End disk (71.060)
- Lined clutch disks (71.050) and inner clutch disks (71.040) in alternating way.
- Wave spring (71.030)



Fig. 158

5.  Sealing element cannot be replaced. In case of damage, replace complete component.

Press piston E (71.100) on cylinder E.



Fig. 159

Assembly

6. Put new lipped seal ring (71.120) on supporting ring.
7. Press supporting ring (71.110) into piston E.



Fig. 160

8. Press down clutch E in arbor press using AA00.858.018 [Assembly fixture] and secure with new round wire ring (71.140).



Fig. 161

11.4 Assembling oil supply

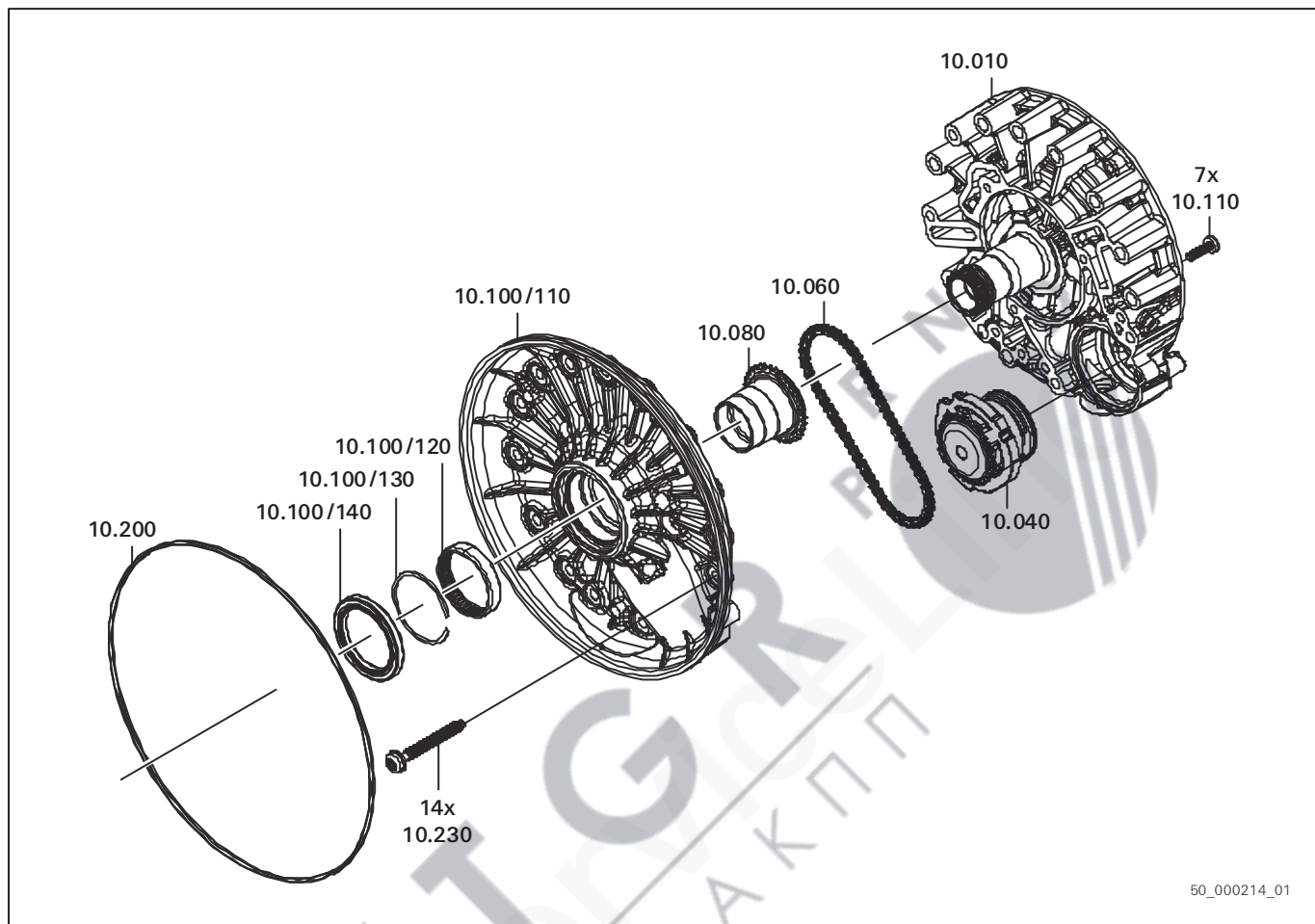

Fig. 162 10 - Oil supply

11.4.1 Installing pump

Special tools:

- 5X46.003.913 Assembly fixture

Assembly

1. Get components ready.
2. Put two new O-rings (10.040/...) and new sealing element (10.040/...) on pump (10.040).

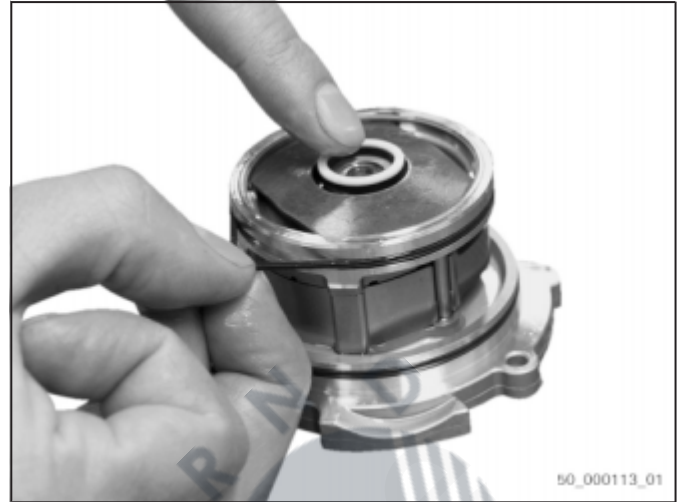



Fig. 163

3. Insert pump with chain (10.060) and driving sprocket (10.080) into intermediate plate (10.010).
4. Rotate pump housing by hand.
 - Pump rotates easily: correct
 - Pump does not rotate or only sluggishly: component wedged.



Fig. 164

5.  The gap size between pump and intermediate plate is about 2 mm.

Firmly press pump onto intermediate plate using 5X46.003.913 [Assembly fixture].

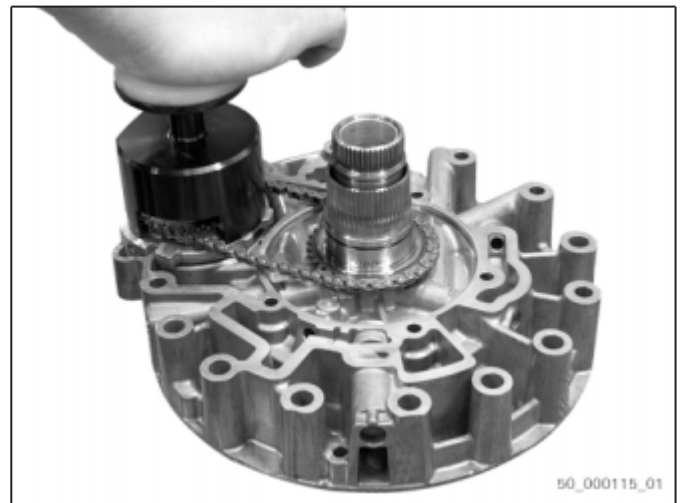

Fig. 165

11.4.2 Assembling oil supply

Special tools:

- 5X46.002.561 Press-in mandrel
- AA00.613.941 Press-in mandrel
- AA00.602.553 Turning device

1.

NOTICE

Property damage due to leakage possible.

⇒ Use 5X46.002.561 [Press-in mandrel].

Put shaft sealing ring (10.100/140) on AA00.613.941 [Press-in mandrel] and press into centering plate.



Fig. 166

2. Put new O-ring (10.200) onto centering plate.



Fig. 167

3.  Pump must be aligned with tool.

Insert intermediate plate into AA00.602.553 [Turning device].

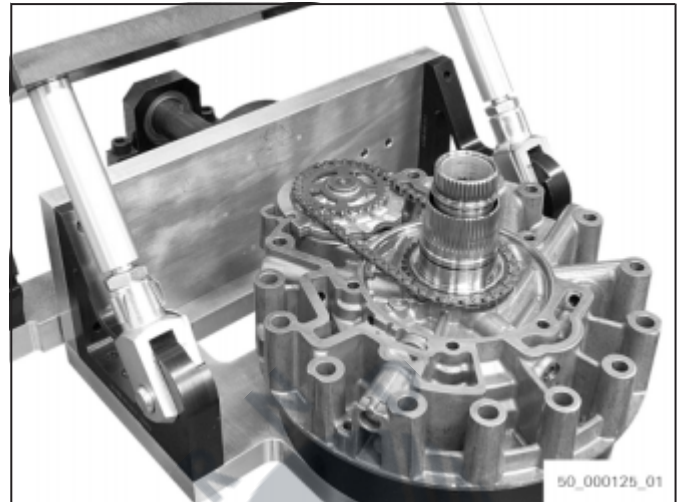

Fig. 168

4. Put on centering plate and align bores.
5. Put downholder on centering plate.
6. Press on centering plate with downholder by rotating the threaded spindle.
Tightening torque: **11 Nm (± 1.1 Nm)**

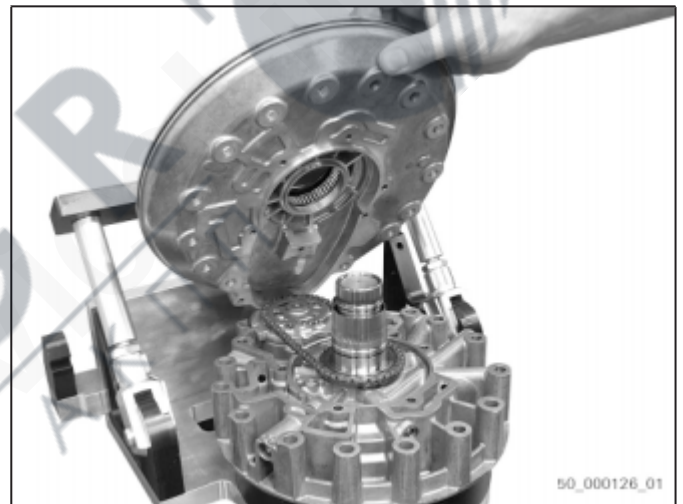



Fig. 169

7.  Observe tightening torque and screw connection directive (refer to section Intermediate plate, page 91).

Loosen locking mechanism of fixture.

8. Turn around centering plate.
9. Screw down centering plate with six new aluminum torx screws (10.110).
Tightening torque: **4.0 Nm (± 0.5 Nm) and 90° ($\pm 5^\circ$)**



Fig. 170

10. Screw in new screw (10.110) into intermediate plate.
11. Loosen clamping device.
12. Remove downholder and oil supply.



Fig. 171

AVTIGRIP
 ВСЕ ДЛЯ АКПП

11.4.3 Assembling brake A

Special tools:

- 5X46.001.502 Assembly fixture

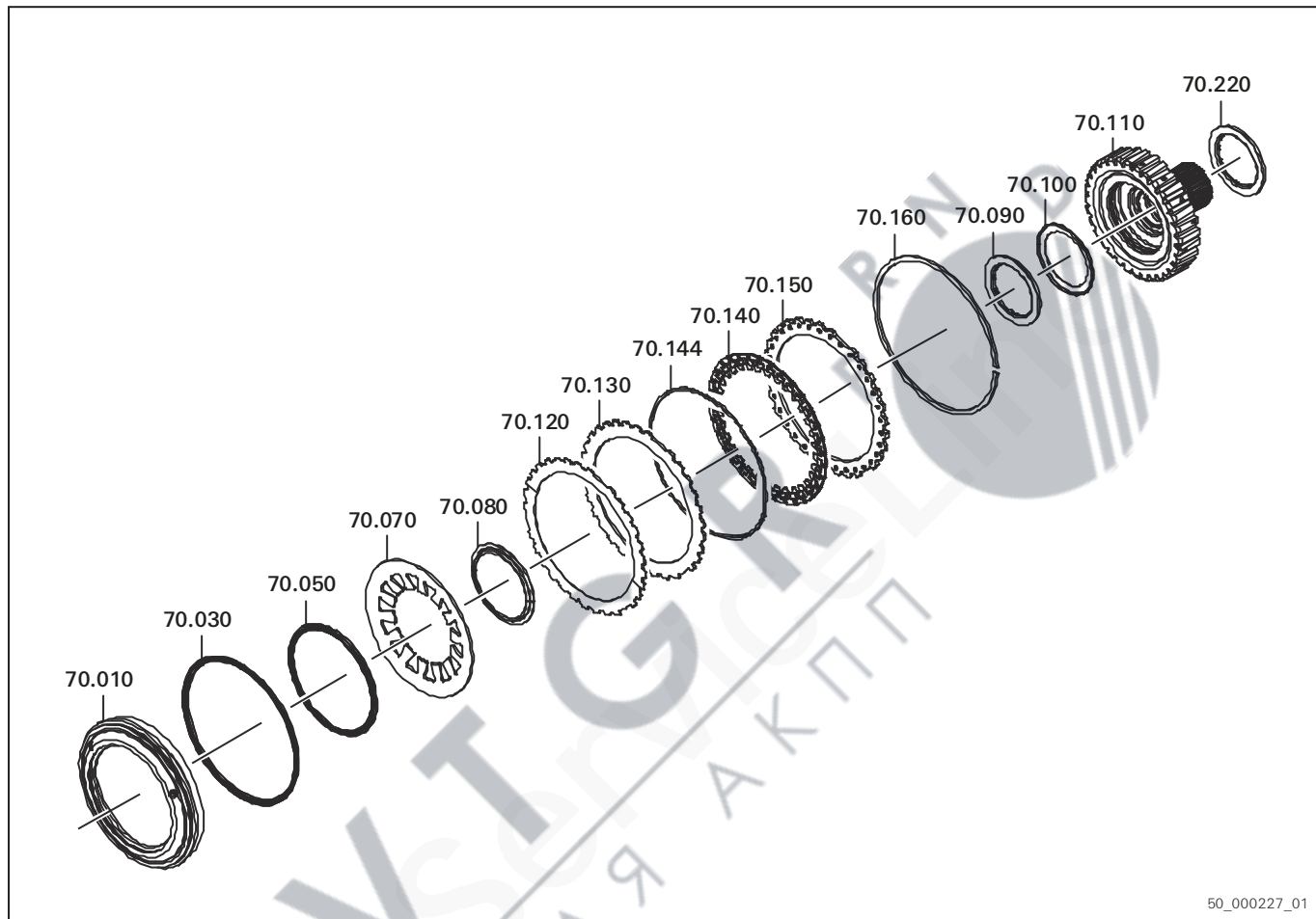

Fig. 172 70 - Brake A

1. Get components ready.

2. Put two new lipped seal rings (70.030, 70.050) on piston A (70.010).
3. Press in piston A into oil supply of cylinder A.



Fig. 173

4. Insert spring disk (70.070) into cylinder A and preload in arbor press using 5X46.001.502 [Assembly fixture].
5. Secure disk spring with split ring (70.080).



Fig. 174

6. Insert axial needle bearing (70.090) and angle disk (70.100) into cylinder A.



Fig. 175

Assembly

7. Put axial needle bearing (70.220) on sun shaft 1 (70.110).
8. Insert multidisk carrier into oil supply.



Fig. 176

9. Center multidisk package.
10.  Observe running clearance settings of brake A (refer to section Setting running clearance of brake A, page 79).

Fit multidisk package:

- Wave spring (70.120)
- Outer clutch disks (70.130) and lined clutch disks (70.140), if required five separation springs (70.144) in alternating way.
- End disk (70.150)

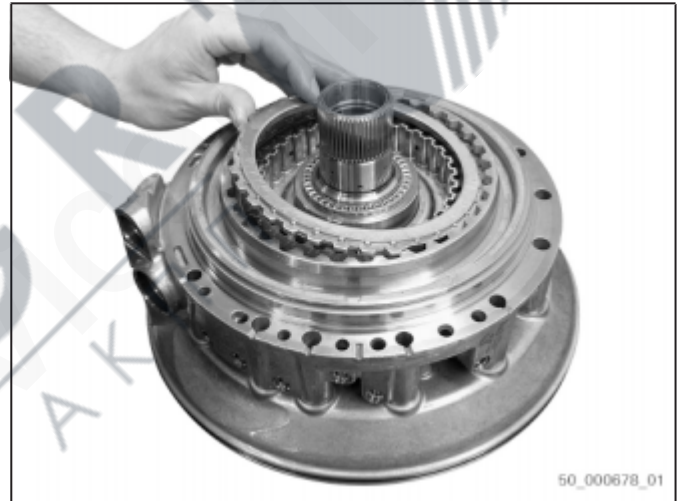

Fig. 177

11. Secure end disk with snap ring (70.160).

11.4.4 Assembling brake B

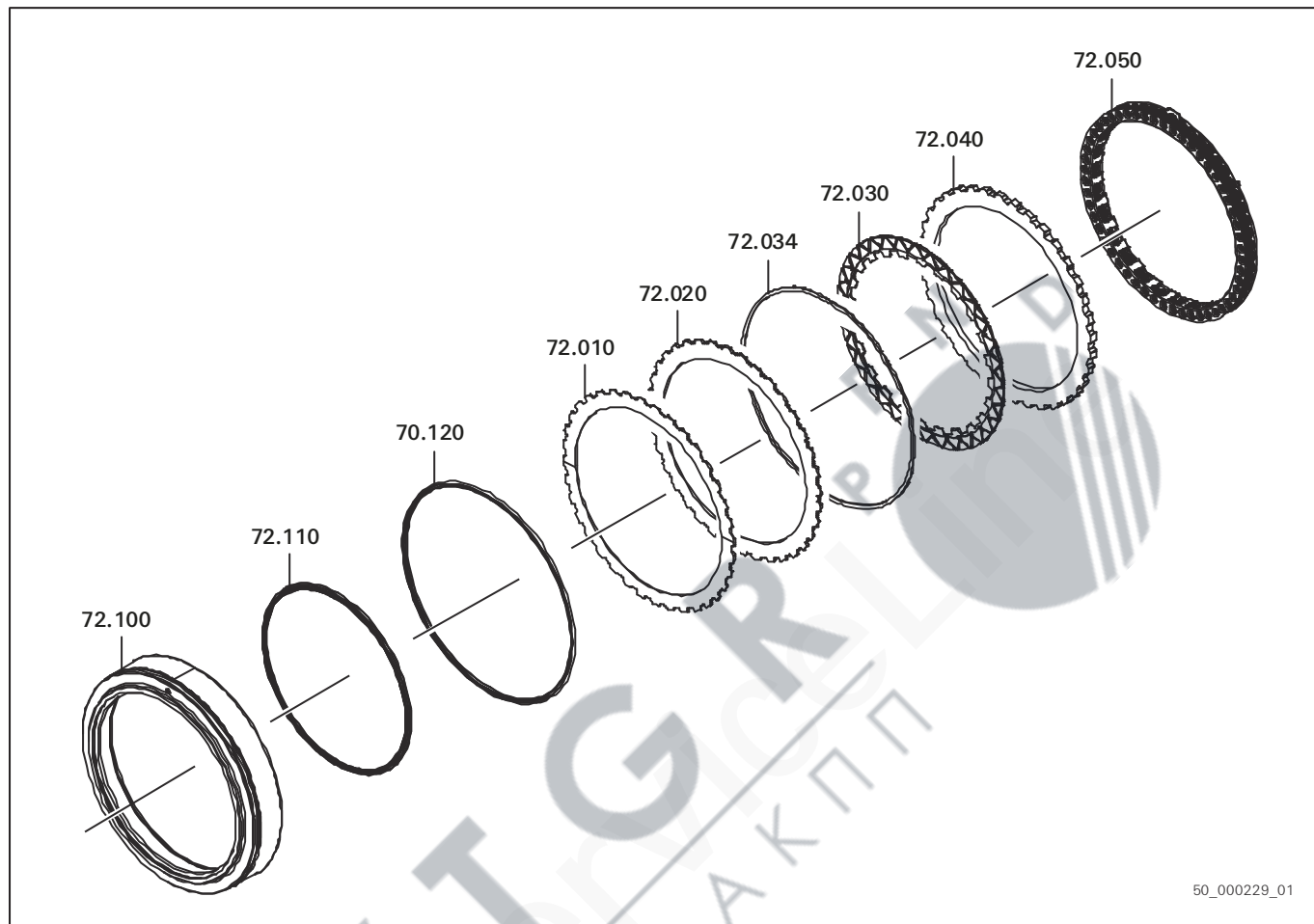

Fig. 178 72 - Brake B

1. Get components ready.
2. Put new lipped seal ring (72.120) on intermediate plate.
3. Put new lipped seal ring (72.110) on piston B.
4. Insert piston B (72.100) into intermediate plate.

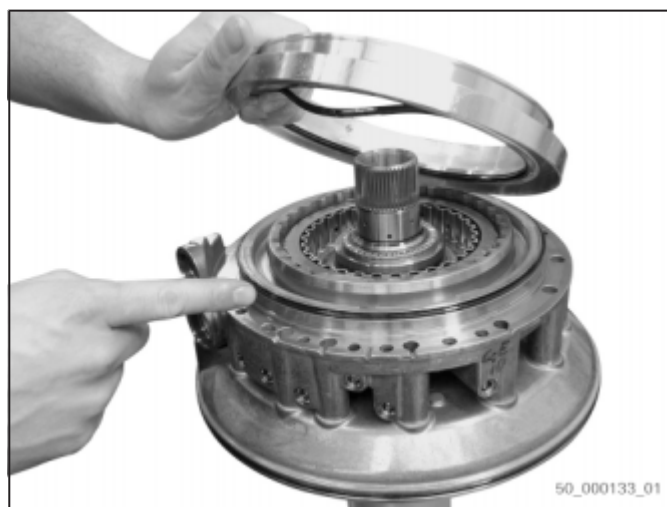



Fig. 179

5.  Observe running clearance settings of brake B (refer to section Setting running clearance of brake B, page 83).

Insert piston B into intermediate plate. Firmly press in piston.



Fig. 180

AVTIGRIP
ВСЕ ДЛЯ АКПП

11.5 Completing tower

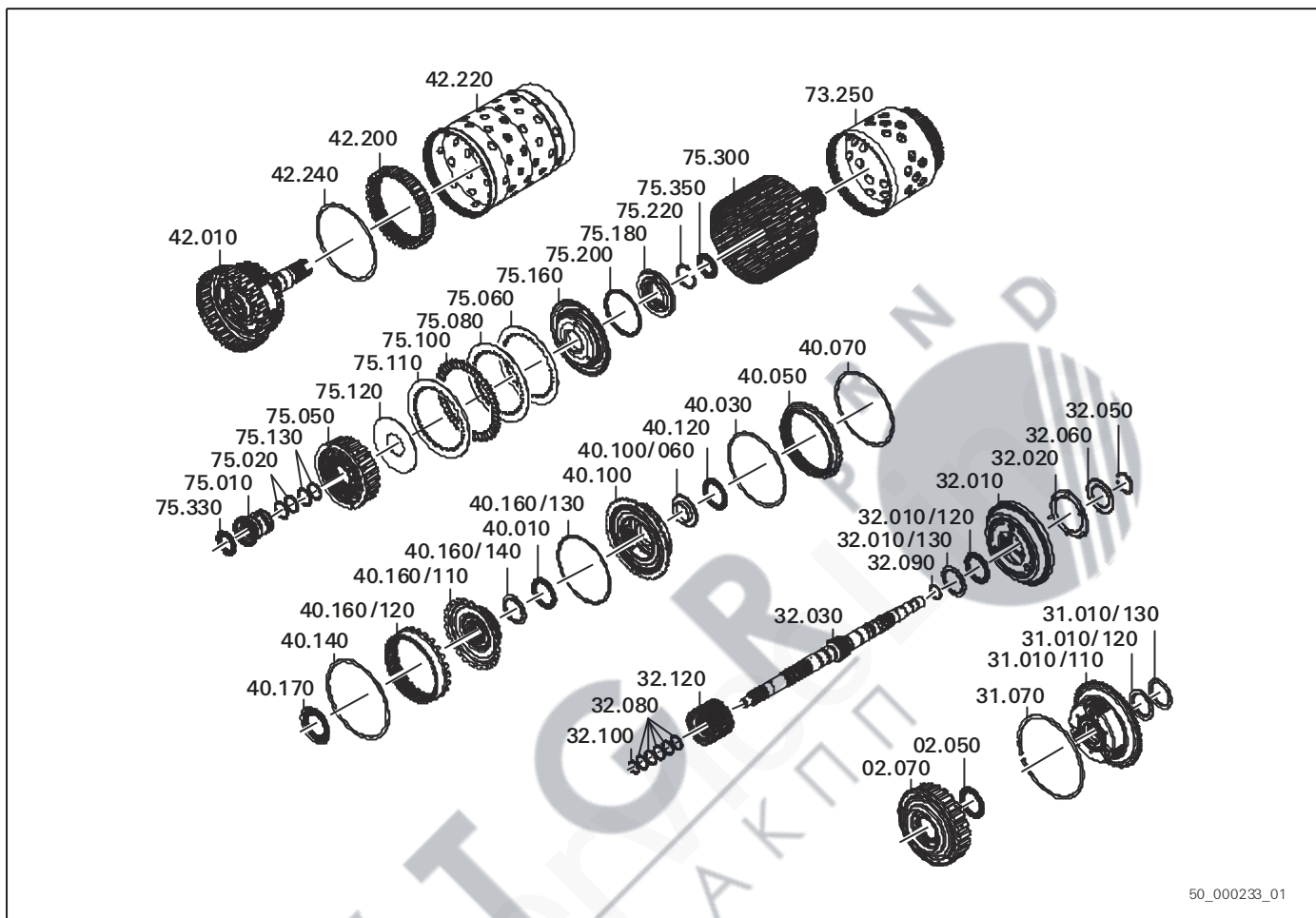

Fig. 181 31 - Planetary gearset 1, 32 - Planetary gearset 2, 40 - Planetary gearset 3, 42 - Planetary gearset 4, 75 - Clutch C

11.5.1 Installing ring gear

1. Insert ring gear 4 (42.200) - heel facing downwards - into pot 1 (42.220).
2. Secure ring gear 4 with new snap ring (42.240).

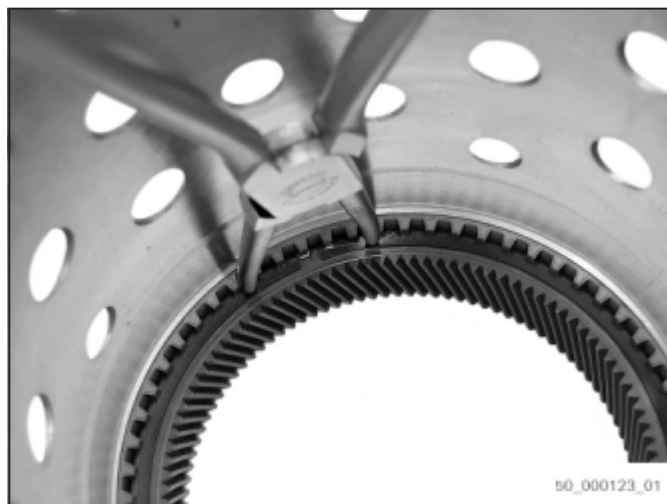

Fig. 182

11.5.2 Installing clutch C/E

Special tools:

- 5X46.004.264 Assembly fixture

1. Insert pot 3 (73.250) into 5X46.004.264 [Assembly fixture].
2. Insert sun shaft 4 (75.300) into pot 3.
3. Insert axial needle bearing (75.350) into sun shaft 4.



Fig. 183

4.  Align clutch disks before inserting them.

Insert clutch C into sun shaft 4.

5. Insert axial needle bearing (75.330) on hub of inner clutch disk carrier C.



Fig. 184

6.  Align clutch disks before inserting them.

Put axial needle bearing (40.010) on clutch E.

7. Insert clutch E into sun shaft.



Fig. 185

11.5.3 Installing planetary gearset 3

Special tools:

- AA00.548.688 Assembly pliers

1. Insert new snap ring (40.070) into sun shaft 4.



Fig. 186

Assembly

2. Insert ring gear 3 (40.050) into sun shaft 4.
3. Secure ring gear 3 and sun shaft 4 with new snap ring (40.030).



Fig. 187

4. Insert planetary drive/planetary gearset 3 (40.100) into ring gear.
5. Insert axial needle bearing (40.120) into planetary gearset 3.
6. Secure pot 3 with new snap ring (40.140). Use AA00.548.688 [Assembly pliers].
7. Remove complete unit from supporting fixture.



Fig. 188

11.5.4 Installing pot 3/pot 1

Special tools:

- 5X46.004.264 Assembly fixture

1. Insert pot 1 using 5X46.004.264 [Assembly fixture].
2. Put output shaft (42.010) into pot 1.



Fig. 189

3. Insert pot 3 into output shaft.



Fig. 190

11.5.5 Installing ring gear/planetary gearset 2

1. Assemble ring gear 2 (40.160/120) and sun gear 3 (40.160) and secure with new snap ring (40.140).
2. Fit angle disk (40.160/140).



Fig. 191

3. Insert ring gear 2 and sun gear 3 into planetary gearset 3.



Fig. 192

4. Put axial needle bearing (40.170) on sun gear 3.



Fig. 193

11.5.6 Installing planetary gearset 2

Special tools:

- AA00.686.190 Supporting plate
- 5X46.003.918 Mounting tool
- AA00.381.834 Assembly fixture

1. Insert input shaft into AA00.686.190 [Supporting plate].



Fig. 194

2. Put planetary drive/planetary gearset 2 (32.010) on input shaft.
3. Secure planetary drive/planetary gearset 2 with new snap ring (32.050). Use 5X46.003.918 [Mounting tool].



Fig. 195

Assembly

4. Install oil drip pan (32.020) and angle disk (32.060) in planet carrier 2.



Fig. 196

5. Install two new rectangular rings (32.090) into input shaft (32.030) using AA00.381.834 [Assembly fixture].

6. Center rectangular rings.
Put AA00.381.834 [Assembly fixture] over input shaft.



Fig. 197

7. Insert input shaft into tower.
8. Insert needle roller bearing (32.010/120) with angle disk (32.010/130) over input shaft.



Fig. 198

9. Install five new rectangular rings (32.080) into input shaft using AA00.381.834 [Assembly fixture].
10. Center rectangular rings.
Put AA00.381.834 [Assembly fixture] over input shaft.



Fig. 199

AVTIGRIP
ВСЕ ДЛЯ АКПП

11.5.7 Installing planetary gearset 1

Special tools:

- AA00.548.688 Assembly pliers

1. Insert sun gear 1/2 (32.120) into planet carrier 2.



Fig. 200

2. Install oil drip pan (31.030) in planet carrier 1.

3. Put planet carrier 1 on sun gear 1/2.



Fig. 201

4. Put axial needle bearing (02.050) with angle disk on planet carrier 1.



Fig. 202

5. Pull pot 1 upwards and secure with new snap ring (31.020). Use AA00.548.688 [Assembly pliers].

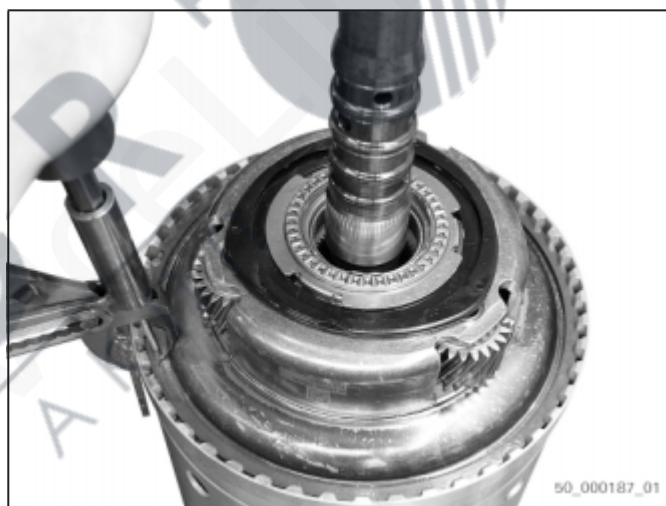

Fig. 203

6. Put ring gear (02.070) with caulked angle disk (02.050) on planet carrier 1.
7. Insert old adjustment plate of backlash (10.210).

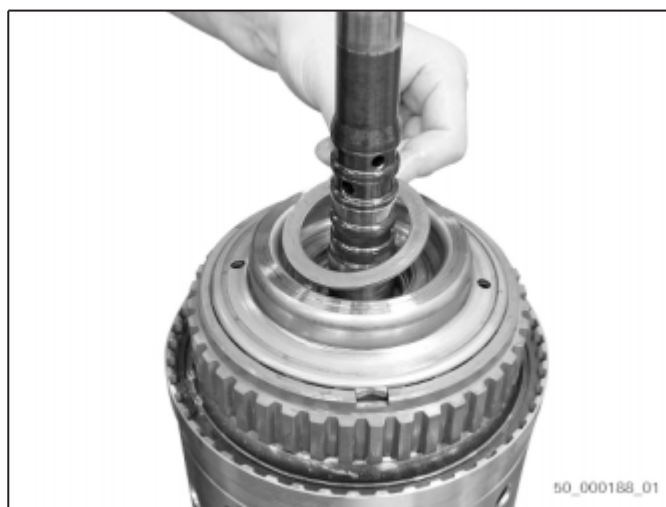

Fig. 204

11.6 Installing tower and oil supply

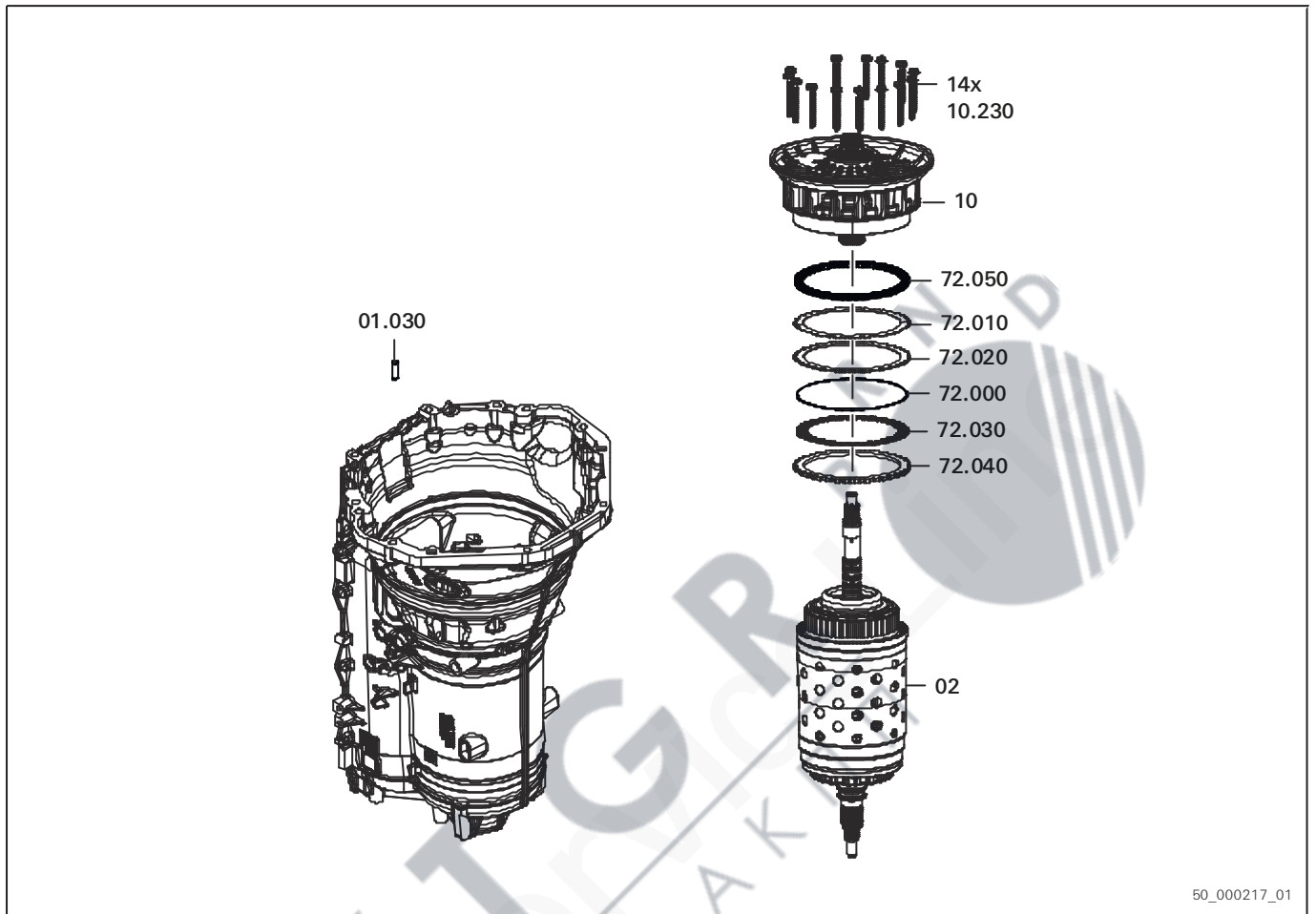

Fig. 205 72 - Brake B, 10 - Oil supply, 02 - Tower

11.6.1 Installing tower

Special tools:

- 5X46.003.957 Tower lifting device
- AA00.615.414 Assembly fixture
- AA00.549.949 Test device

1. Place transmission with input end facing upwards.
2. Put 5X46.003.957 [Tower lifting device] on input shaft and fix with slide.

3.



 WARNING
<p>Risk of injury due to falling parts. Death or serious injury possible.</p> <p>⇒ Secure parts against falling down. ⇒ Do not stand beneath a suspended load. ⇒ Do not work on a suspended load.</p>



Fig. 206

Insert tower into transmission housing using tower lifting device and crane.

4.  Observe running clearance settings of brake B (refer to section Setting running clearance of brake B, page 83).

Insert multidisk package of brake B:

- Starting with an end disk (72.040)
- Five lined clutch disks (72.030), if required also five separation springs (72.034) and five outer clutch disks (72.020) in alternating way.
- At the end, insert a wave spring (72.010).



Fig. 207

5. **For one transmission housing only:**
Insert cylindrical pin (01.030) into AA00.615.414 [Assembly fixture].



Fig. 208

6. Drive in cylindrical pin (01.030) into transmission housing using AA00.615.414 [Assembly fixture].



Fig. 209

7.

NOTICE

Rectangular rings might be damaged during assembly.

⇒ Use AA00.549.949 [Test device].

Push AA00.549.949 [Test device] over input shaft until end stop. Remove tool again.



Fig. 210

8.  Insert spring assembly lugs facing downwards and exactly into recesses.

Insert spring assembly (72.050) into tower.



Fig. 211

11.6.2 Installing oil supply

Special tools:

- AA00.549.802 Disassembly device
- AA00.373.240 Sealing device

1.  Observe backlash (refer to section Setting backlash, page 86).

Insert oil supply into transmission housing using AA00.549.802 [Disassembly device] and press on.

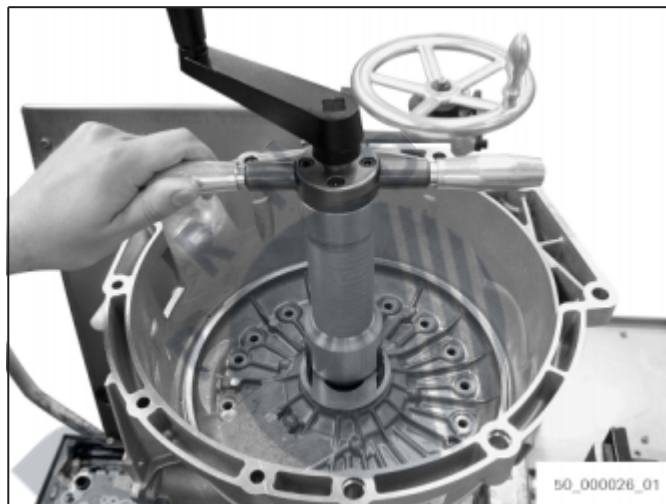



Fig. 21 2

2.  Observe tightening torque and screw connection directive (refer to section Oil supply, page 88).

Fix oil supply with 14 new torx screws (10.230).
Tightening torque: **10 Nm (±1.0 Nm) and 90° (±5°)**



Fig. 21 3

3. Place transmission housing with oil pan facing upwards.

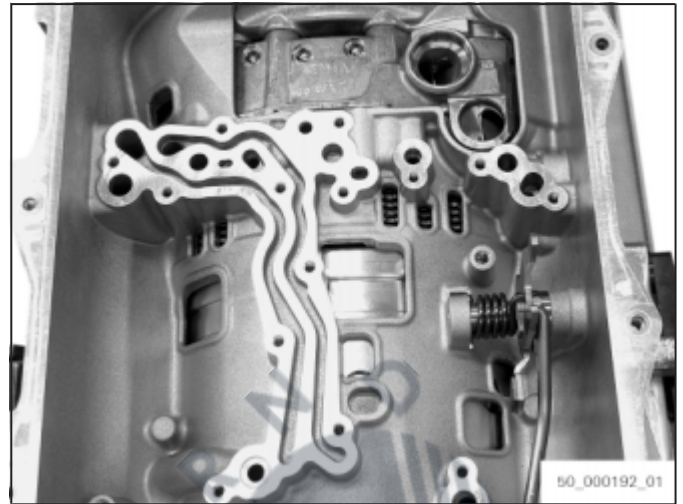



Fig. 21 4

4.  Check clutch for leakages using a compressed air spray gun.

Put AA00.373.240 [Sealing device] on housing and fix with screws.

5. Press off clutches using compressed air.
6. Remove plate.



Fig. 21 5

11.7 Installing Mechatronic and hydraulic impulse oil storage

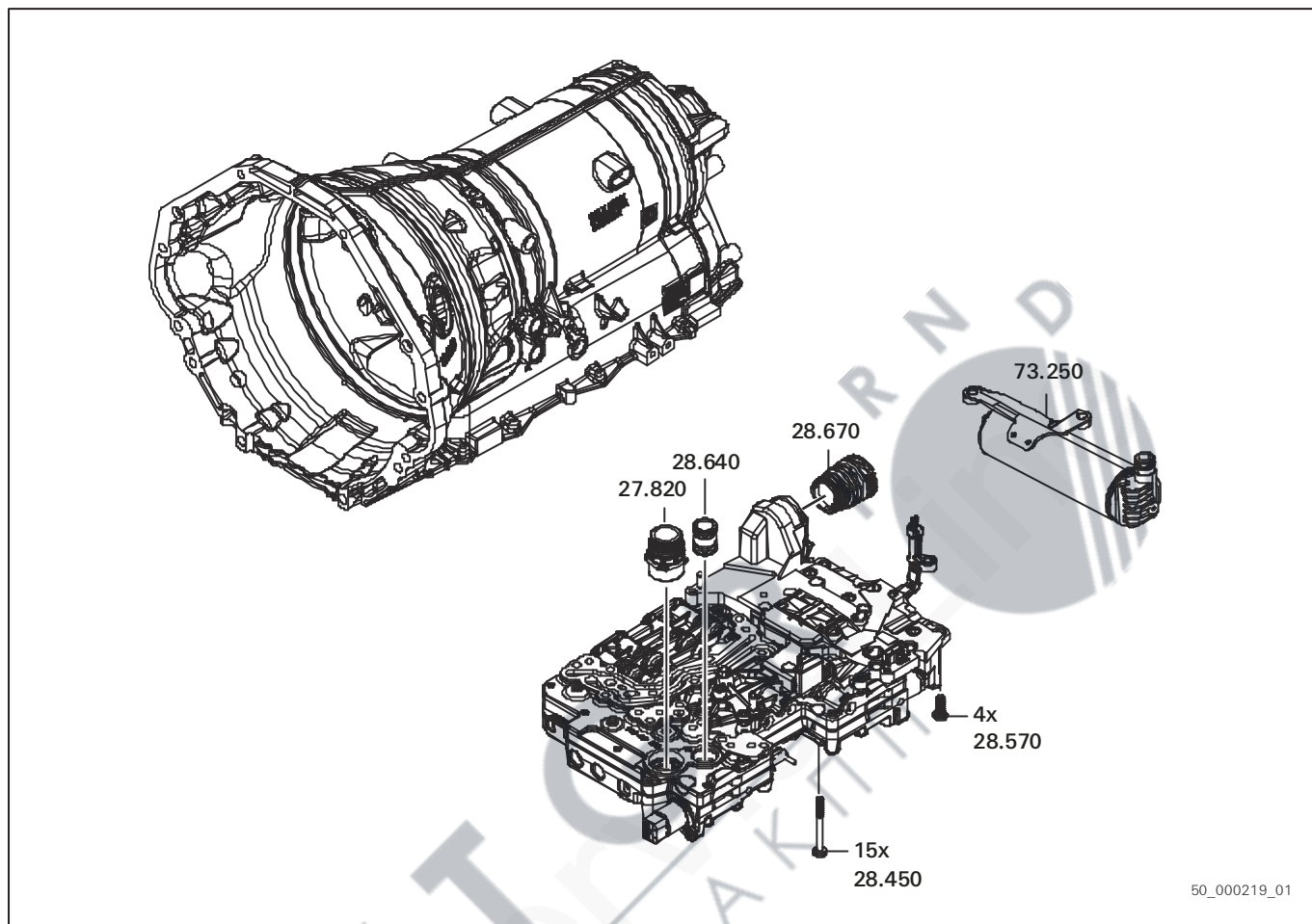

Fig. 216 28 - Mechatronic

11.7.1 Installing Mechatronic

- i** Observe tightening torque and screw connection directive (refer to section Mechatronic and hydraulic impulse oil storage, page 89).

Assembly

1. Insert new pressure tube (28.640) into Mechatronic.

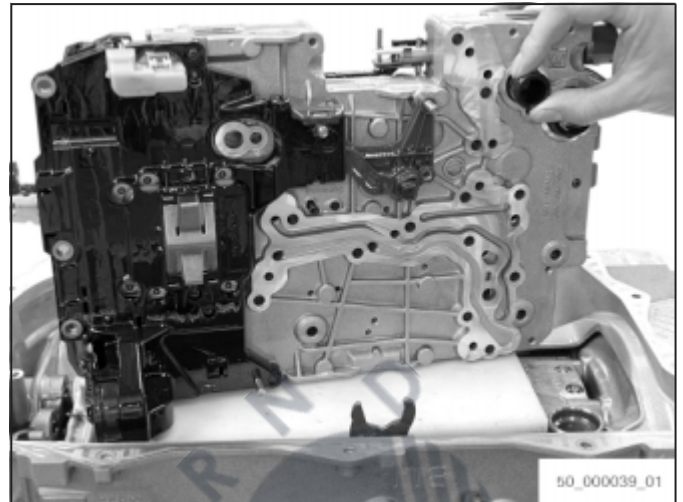

Fig. 21 7

2. Put on Mechatronic.
3. Fit parking disk into Mechatronic and align.
4. Screw 14 torx screws (28.450) into Mechatronic.
Tightening torque: **8 Nm (± 0.8 Nm)**

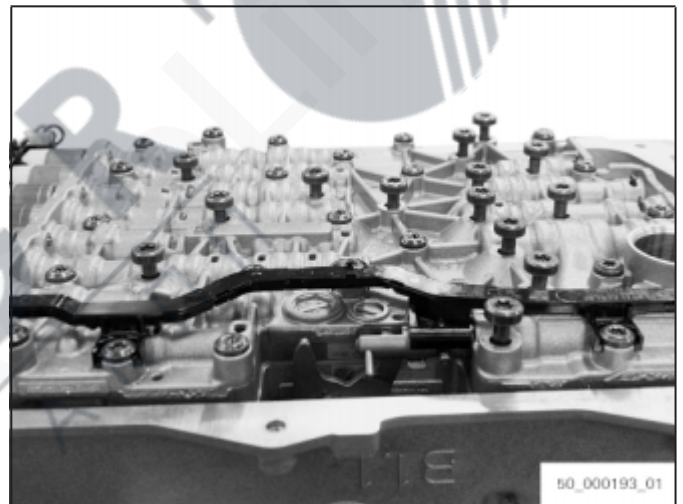

Fig. 21 8

5. Insert new guiding sleeve (28.670) and lock link.



Fig. 21 9

6. Screw two torx screws (28.570) into Mechatronic.
Tightening torque: **8 Nm (± 0.8 Nm)**

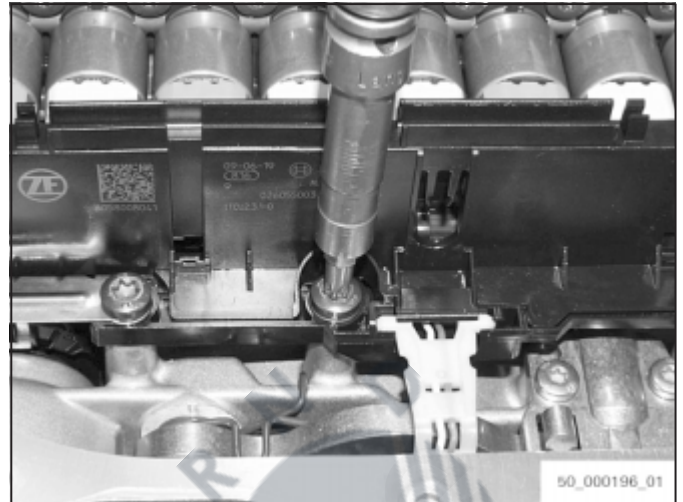

Fig. 220

7. **NOTICE**
The dog point at the output speed sensor might break during disassembly or assembly.
⇒ Carefully insert output speed sensor into parking position.

Insert output speed sensor into groove of transmission housing and fix with one torx screw (28.580).

Tightening torque: **8 Nm (± 0.8 Nm)**

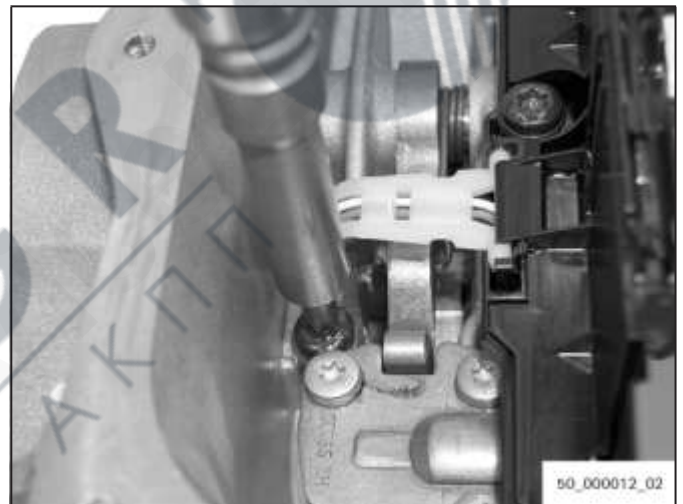

Fig. 221

11.7.2 Installing hydraulic impulse oil storage

- i** Observe tightening torque and screw connection directive (refer to section Mechatronic and hydraulic impulse oil storage, page 89).

NOTICE

Property damage due to electrostatic discharge (ESD) possible.

- ⇒ Observe ESD protection.
- ⇒ Do not touch contacts.
- ⇒ Wear conductive workwear.
- ⇒ Use ESD transport protection.
- ⇒ Use ESD protective packaging.

1.

NOTICE

Property damage due to leakage at delivery connection of HIS possible.

⇒ Remove O-ring without tool.

Put on new O-ring on delivery connection of HIS (28.680).



Fig. 22.2

2. Insert HIS into transmission housing and fix with one long torx screw (28.450) Tightening torque: **8 Nm (± 0.8 Nm)** and two short torx screws (28.570) Tightening torque: **8 Nm (± 0.8 Nm)**.

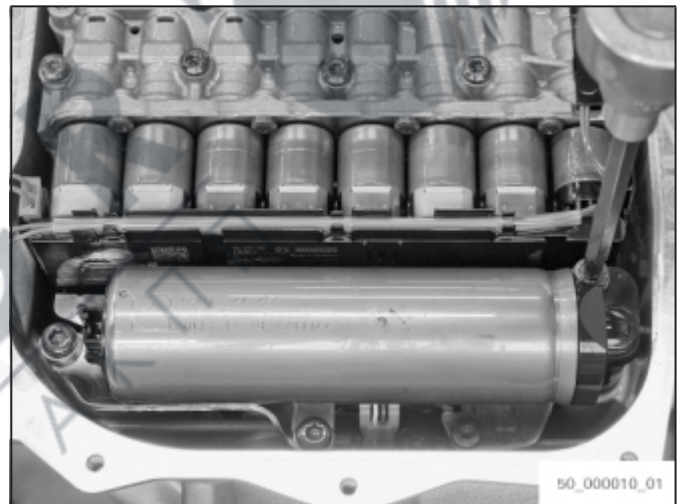

Fig. 22.3

3. Plug in cable plug into HIS.

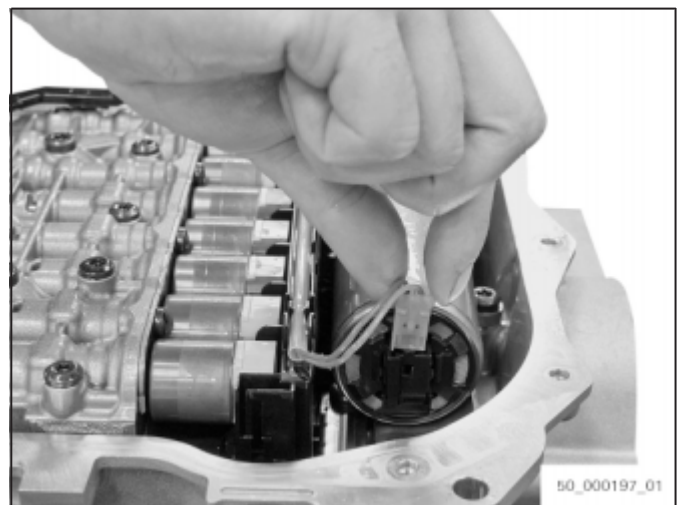



Fig. 22.4

11.8 Fitting oil pan

 Oil pan is delivered with screw plug tightened.

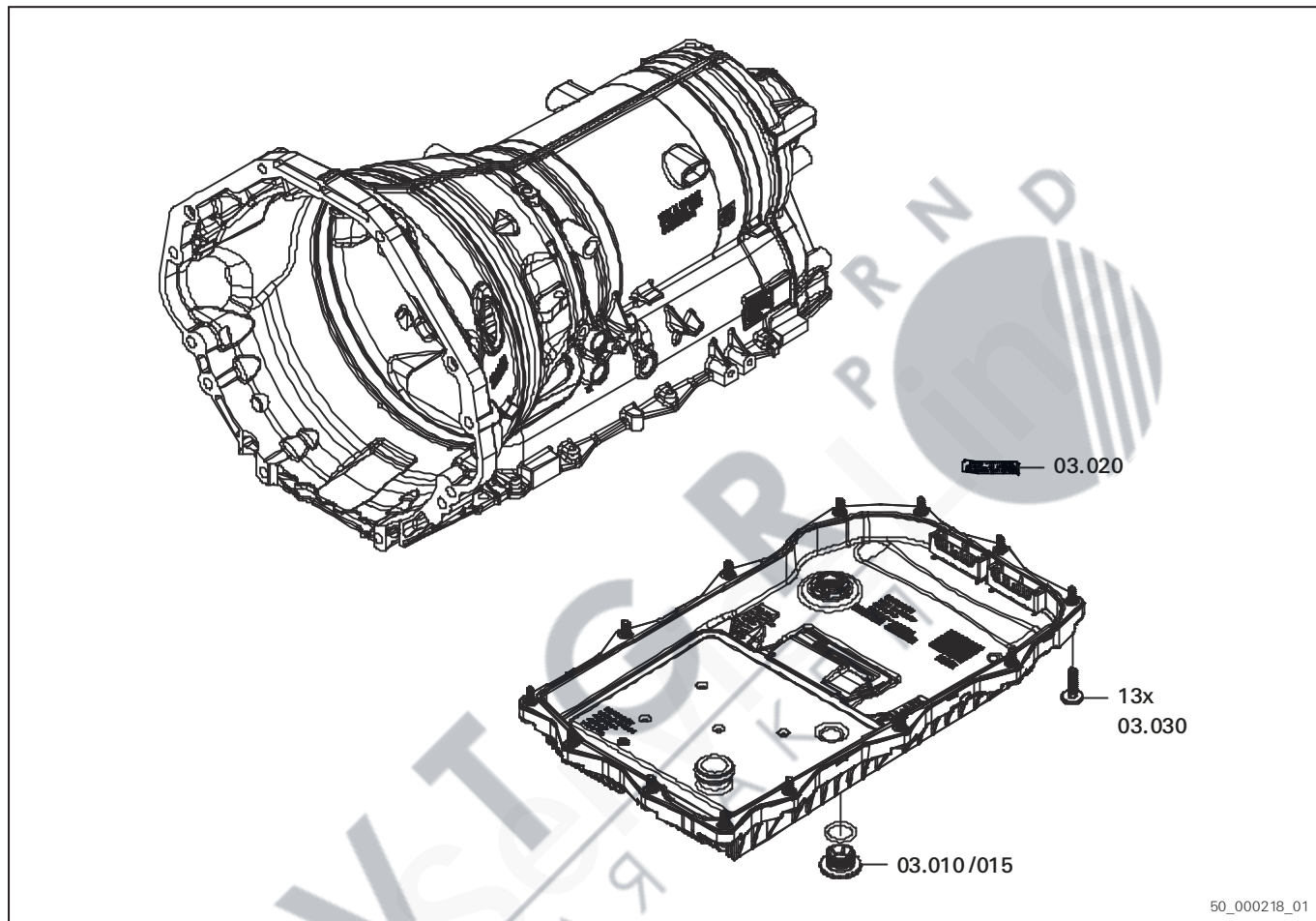



Fig. 225 03 - Oil pan

1. Get components ready.

2.  Before fitting the oil pan, check all plug connections at Mechatronic/control unit by pulling if they fit correctly and press in.

-  Observe tightening torque and screw connection directive (refer to section Oil pan , page 90).

Put new oil pan (03.010) on transmission housing.

3. Fix oil pan with 13 new torx screws (03.030).
Tightening torque: **10 Nm (± 1.0 Nm)**

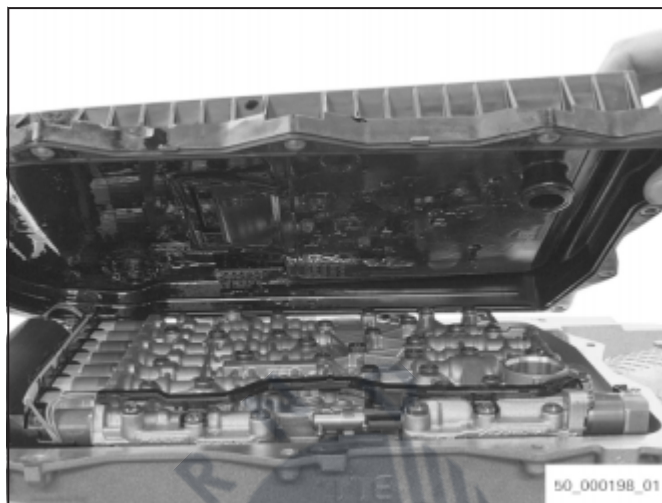

Fig. 22.6

AVTIGRIP
ВСЕ ДЛЯ АКПП

11.9 Fitting output

Special tools:

- AA00.575.099 Assembly fixture
- 5X46.004.217 Assembly fixture

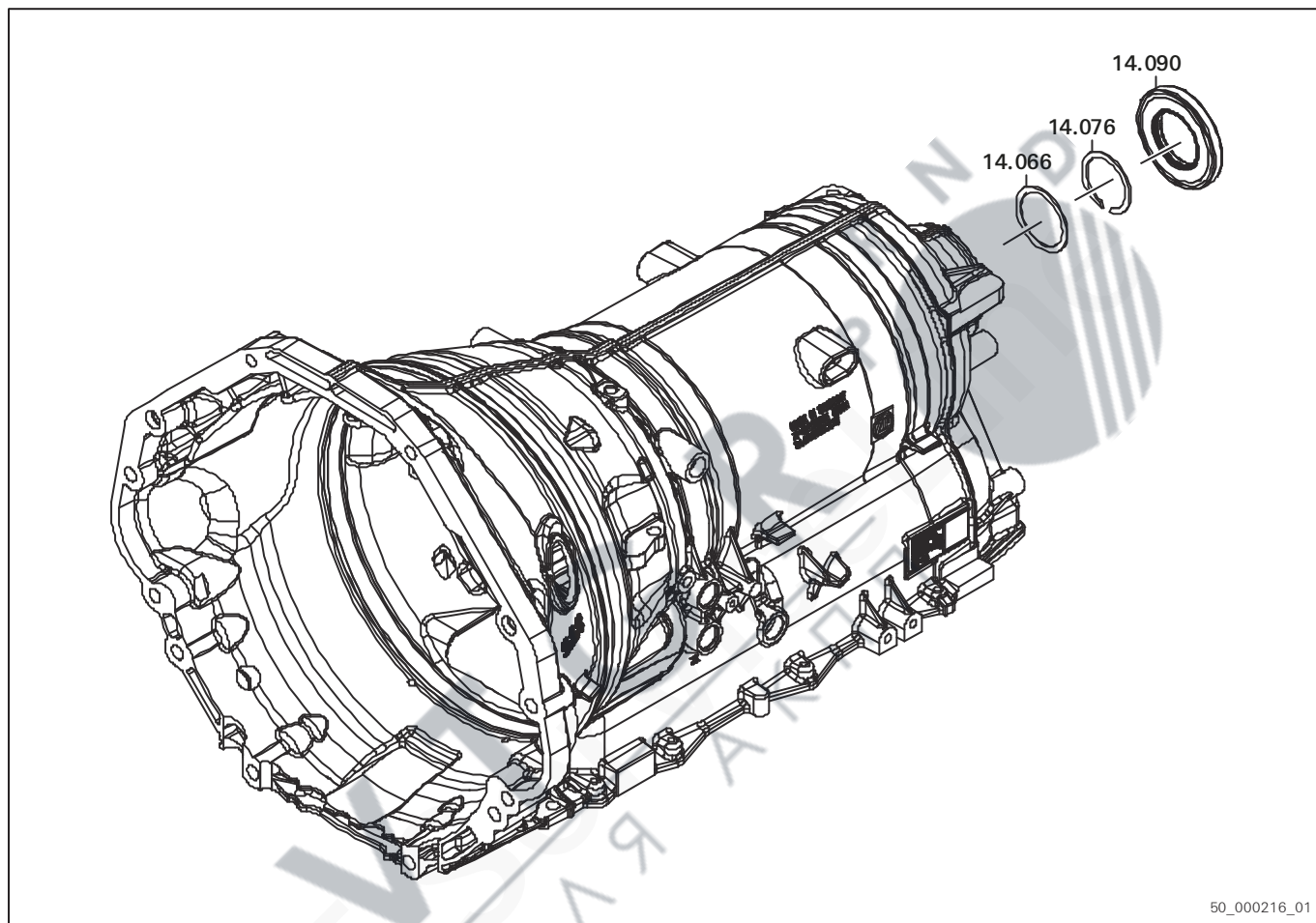

Fig. 227 14 - Output

1. Get components ready.

Assembly

2. Place transmission with input end facing downwards.
3. Insert thrust washer (14.066).

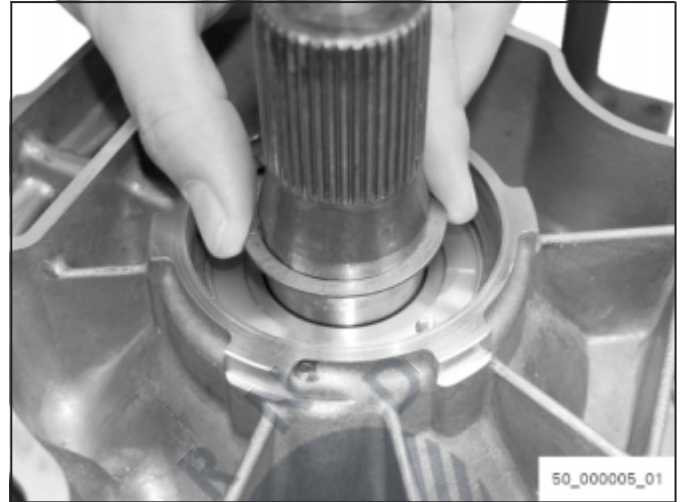

Fig. 228

4. Put AA00.575.099 [Assembly fixture] on output shaft.
5. Place new snap ring (14.076) using assembly fixture.
6. Fit snap ring using AA00.575.099 [Assembly fixture].

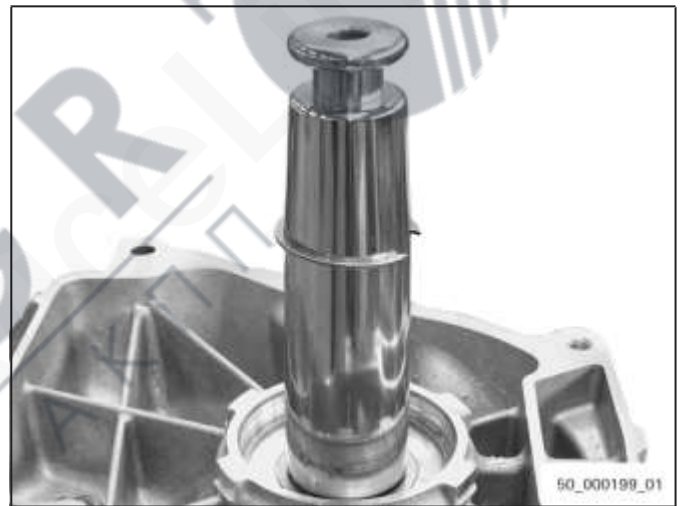

Fig. 229

7.

NOTICE

Property damage due to leakage possible.

⇒ Use 5X46.004.217 [Assembly fixture].

Put 5X46.004.217 [Assembly fixture] on output shaft.

8. Position shaft sealing ring (14.090) on 5X46.004.217 [Assembly fixture].
9. Drive in shaft sealing ring using 5X46.004.217 [Assembly fixture].



Fig. 230

11.10 Installing torque converter

Special tools:

- 5X46.002.807 Lifting gear

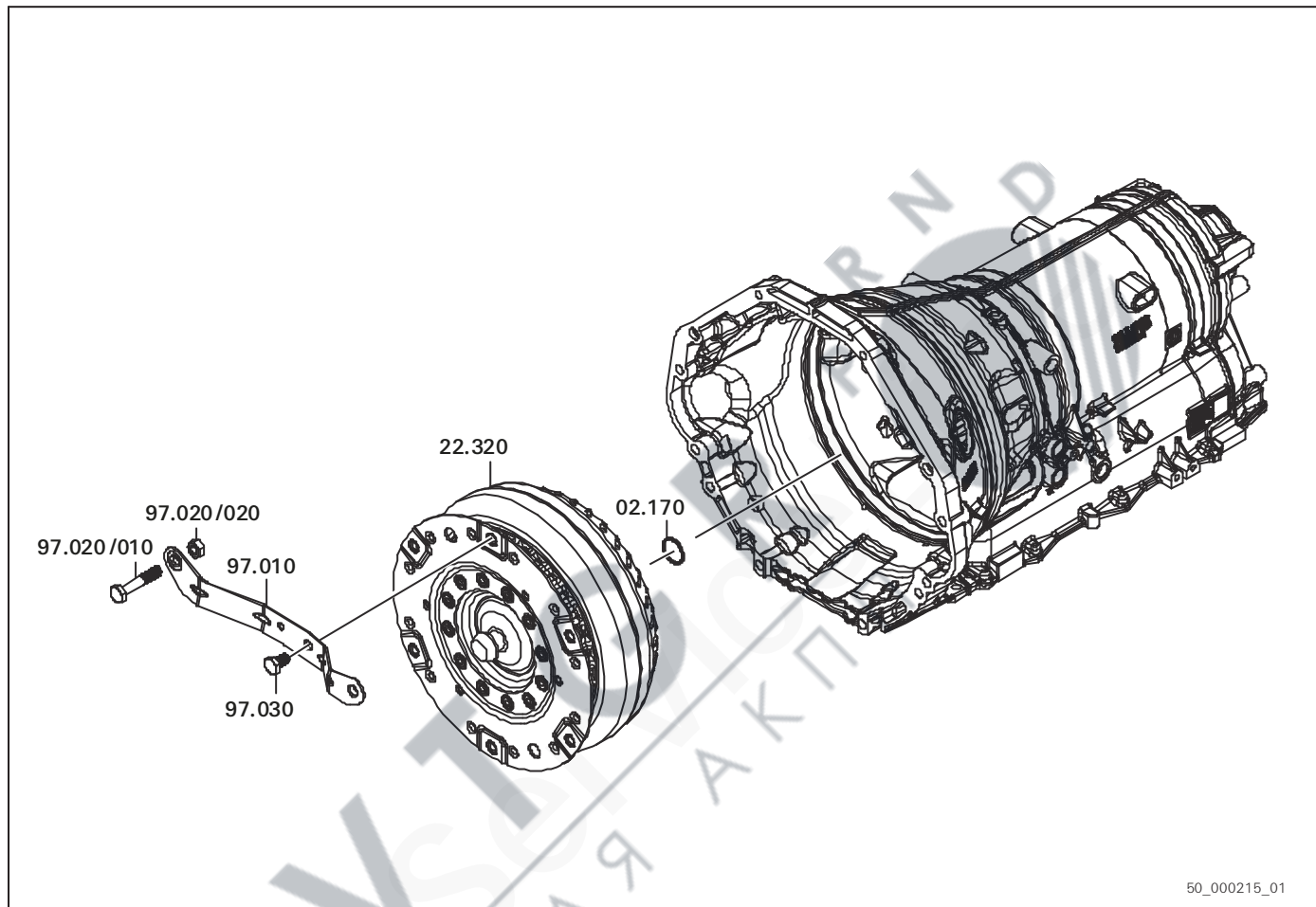

Fig. 231 22 - Torque converter, 97 - Retaining bracket

1. Get components ready.

2. Place transmission with input end facing upwards.
3. Put O-ring (02.170) on input shaft.

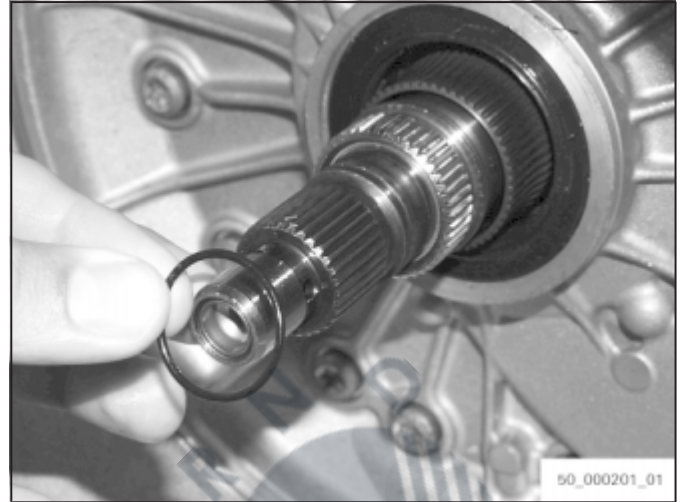



Fig. 232

4.

 WARNING
Risk of injury due to falling parts. Death or serious injury possible.
⇒ Secure parts against falling down.
⇒ Do not stand beneath a suspended load.
⇒ Do not work on a suspended load.

Insert torque converter (22.320) using 5X46.002.807 [Lifting gear].



Fig. 233

5. Fix torque converter retaining bracket (97.010) at torque converter and transmission housing using a short screw (97.030) Tightening torque: **4.5 Nm (± 0.45 Nm)** and two long bolts (97.020) Tightening torque: **4.5 Nm (± 0.45 Nm)**.

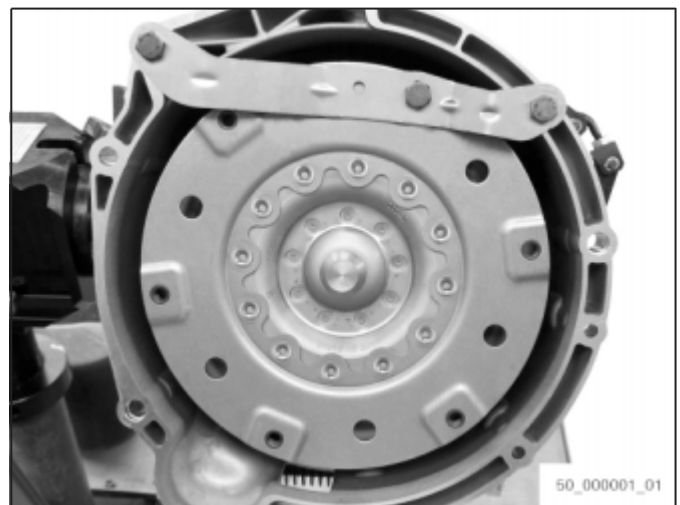

Fig. 234

11.11 Screwing in screw plugs

1. Screw in new PZT screw plug (01.100) into transmission housing.
Tightening torque: **12 Nm (± 1.2 Nm)**

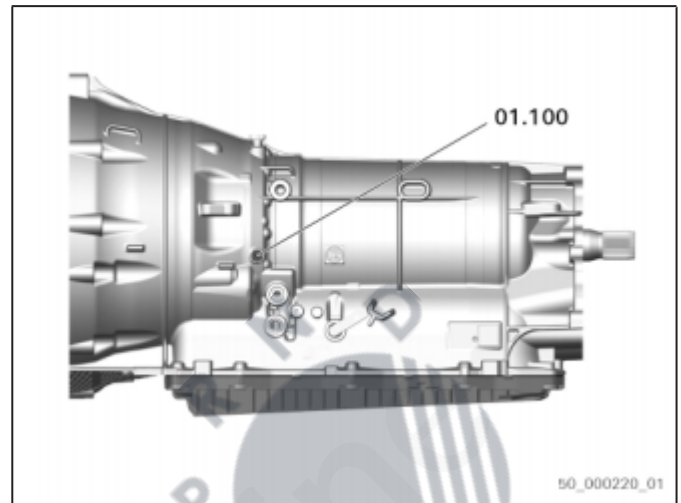

Fig. 235 PZT screw plug

2. Screw in new screw plug for oil fill (01.120) into transmission housing.
Tightening torque: **35 Nm (± 3.5 Nm)**

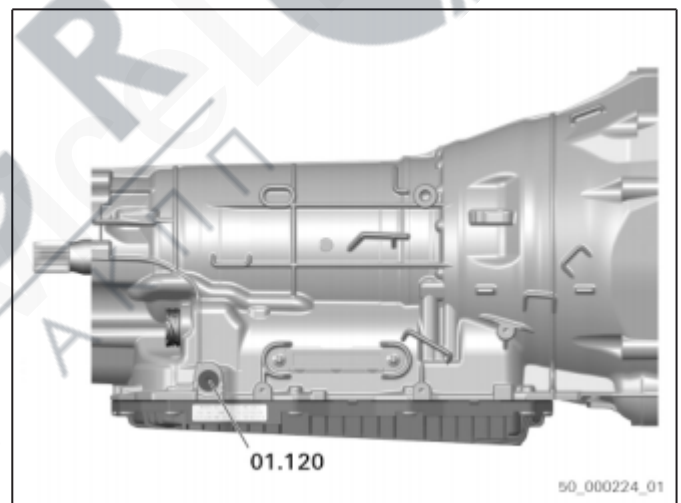

Fig. 236 Oil fill screw plug

3. **In case of new transmission housing:**
Drive in breather tube (01.070) using a plastic hammer until it no longer protrudes. Insert breather cover (01.080) into breather tube.

12 Annex**12.1 List of abbreviations**

HIS hydraulic impulse oil storage

12.2 Overview of revisions

Index	Date of issue	Initiator	Chapter	Comment
1.0	2016-09	MAPO14 Dept.	-	First edition
1.1	2017-03	MAPO14 Dept.	Preface Safety Instructions	Additional information

Tab. 2 Overview of revisions



AVTIGR
БС Е Д А Р Я А К П П Е

ZF Friedrichshafen AG

ZF Aftermarket

Metzer Straße 160

66117 Saarbrücken

Deutschland · Germany

Telefon/Phone +49 681 920-0

www.zf.com/contact