

REPAIR MANUAL



6 HP-19 X

constitutive to repair manual 6 HP 19

AVTGR
BCE AVR AKT



ZF GETRIEBE GMBH SAARBRÜCKEN

Version 07/04/20
CD



subject to alterations

© Copyright 2007 all rights reserved and published by
ZF Getriebe GmbH, Saarbrücken, Department MKTD

No part of this manual may be reproduced or transmitted in any form or
by any means, electronic or mechanical, including photocopying and recording,
for any purpose without the express written permission of
ZF Getriebe GmbH, Saarbrücken

Printed in Germany

Contents

Advance Information	ii
1. General	1.1/1
1.1 Illustration of transmission	1.1/1
1.3 Instructions	1.3/1
1.3.1 Screw connection instructions	1.3/1
1.3.1.1 Oil pan-plastic	1.3/1
1.3.1.2 Oil pan-steel	1.3/1
1.4 Adjusting procedure	1.4/1
1.4.6 Clearance - output	1.4/1
1.5 Tightening torques	1.5/1
1.7 Special tools	1.7/1
2. Disassembly	2.1/1
2.1 Transmission disassembly according to component groups	2.1/1
2.6 Rear axle output	2.6/1
2.6.1 Remove output shaft	2.6/1
2.6.2 Remove bearing (output)	2.6/1
2.7 Gearbox housing and parking lock	2.7/1
3. Assembly	3.1/1
3.1 Gearbox housing and parking lock	3.1/1
3.2 Output shaft	3.2/1
3.7 Fit oil pan	3.7/1



Advance Information

These instructions contain the procedure for repair work on the complete transmission, **which differs to the standard transmission.**

The repair instructions will only be understood sufficiently in combination with ZFS training. Neglecting this could lead to installation errors.

All disassembly and assembly work is listed in chronological order.

Photos and illustrations for the various applications are general in character and not binding for every individual case.

Important changes and those relevant to specific applications that have to be considered during repair work are announced in *Technical Circular Letters* and training courses.

During the repair work SDM regulations and specifications must be observed.

Please note the following:

- Seals, e.g. O-rings, shaft sealing rings, gaskets and filters must always be renewed.
- During assembly, all O-rings, cylindrical rings and other sealing rings must be greased with Vaseline before mounting (excepting metallic seals which must be dry and grease-free).
- All bearings must be slightly oiled when installed.
- Exchange all lining and steel disks in transmissions with higher distance readings (> 80,000 kilometers / 50,000 miles).
- After clutch / brake damage, converters, oil pipes and oil coolers must be cleaned out thoroughly and sufficiently with an appropriate cleaning agent.

The following requirements should be satisfied before starting the repair work:

- Availability of the necessary special tools otherwise assembly faults are possible.
Chapter 1.8 lists the complete set of special tools.
- Availability of a suitable transmission test rig.
For the necessary test values, please refer to the *Technical Circular Letters*.

Note:

The control unit is treated as a complete unit in the instructions and should not be disassembled without special knowledge, but replaced in its entirety.

Dedicated instructions are planned for the control unit gear.

When assembling the control unit do not touch the contact area of the mechatronic and the cable plug (ESD direction).

Attention:

The gearbox is filled with life span oil.

Replacing the oil is not necessary before 160,000 km or 10 years.

The gearbox may only be delivered with the quantity and the type of oil indicated in the respective parts list document (see SDM).

Techn. KD

Techn. Documentation

KD Training

Bach

Reus

Schultz



1. General
1.1 Illustration of transmission

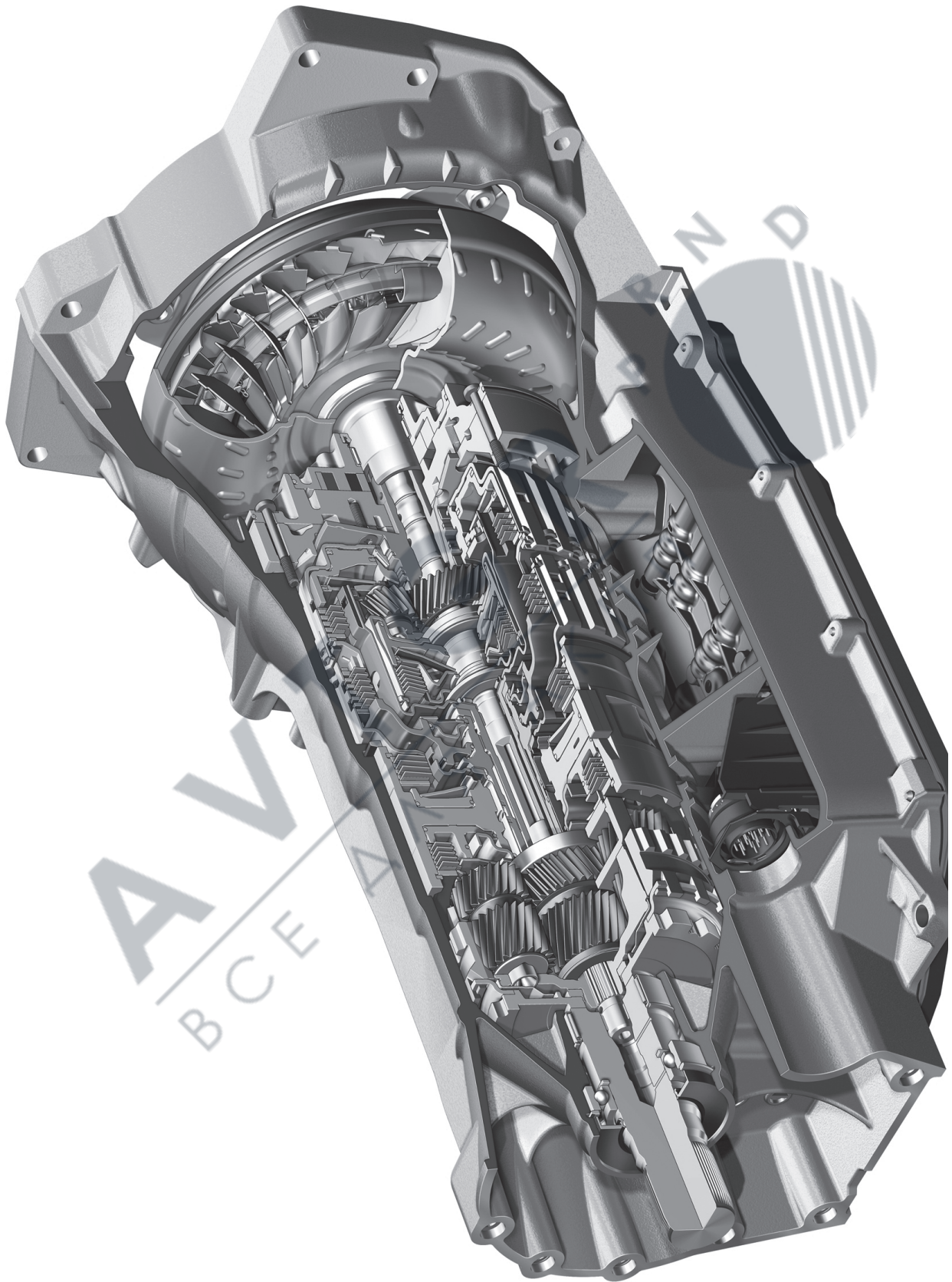



1.3 Instructions

1.3.1 Screw connection instructions

1.3.1.1 Oil pan-plastic

Tighten the 24 oil pan torques according to the numbering:

1 ⇔ 2 ⇔ 3 ⇔ ... ⇔ 24

Important!

Instruction 1071 700 087

(Tightening torques, see Chapter 1.5)

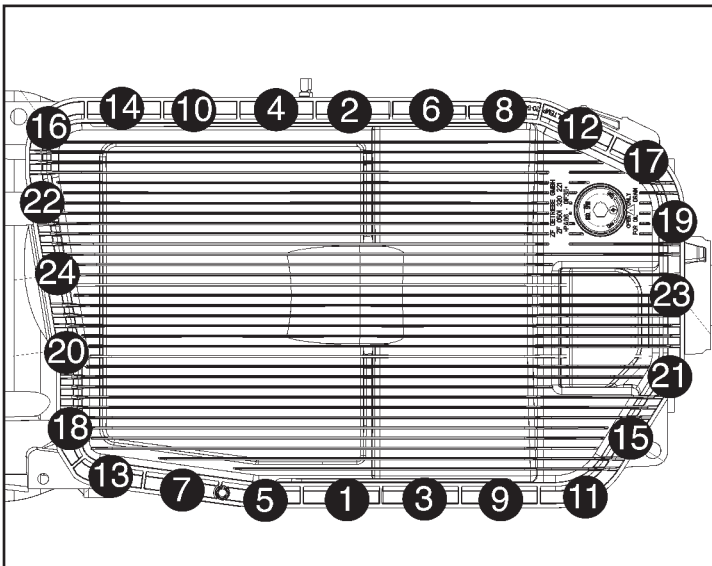

1.3.1.2 Oil pan-steel

Tighten the 13 oil pan torques according to the numbering:

1 ⇔ 2 ⇔ 3 ⇔ ... ⇔ 13

Important!

Instruction 1071 700 097

(Tightening torques, see Chapter 1.5)

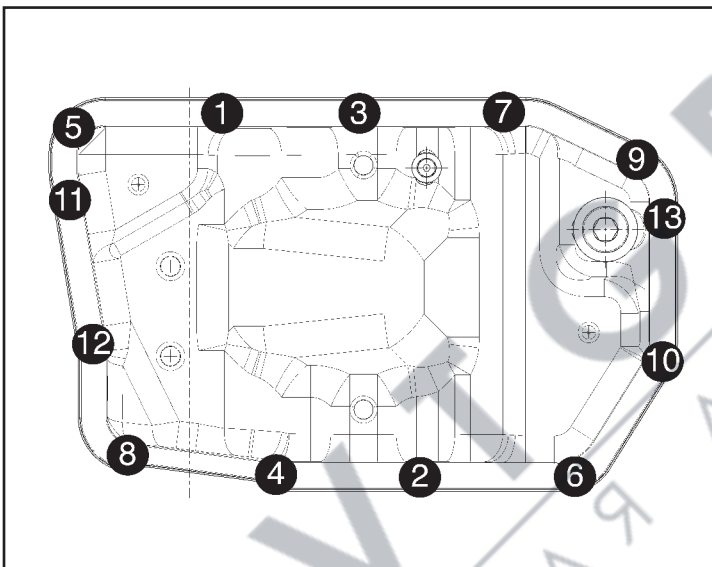



1.4 Adjusting procedure

1.4.6 Clearance - output

Screw the measuring stand 5p01 010 347 into the hole provided in the transmission casing and place the dial gauge on the output shaft. Press on output shaft and set the dial gauge to "0".

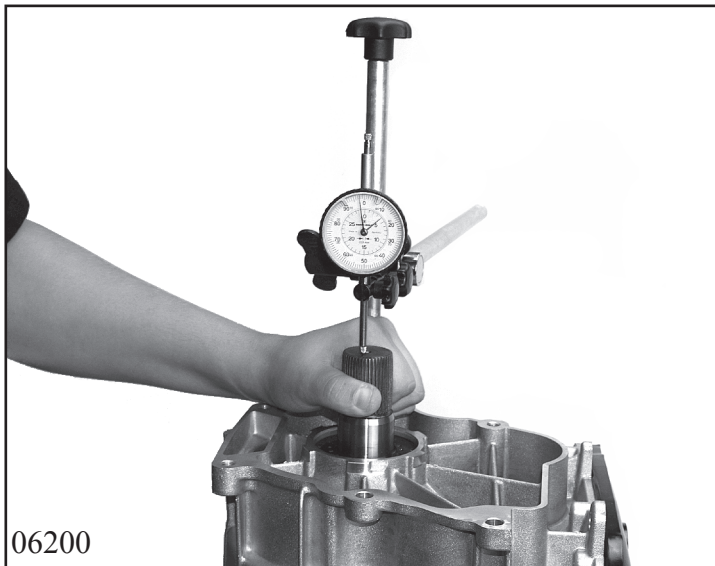

Pull on the output shaft and read off measurement A. Select a thicker or thinner washer if dimension A is beyond tolerance C.

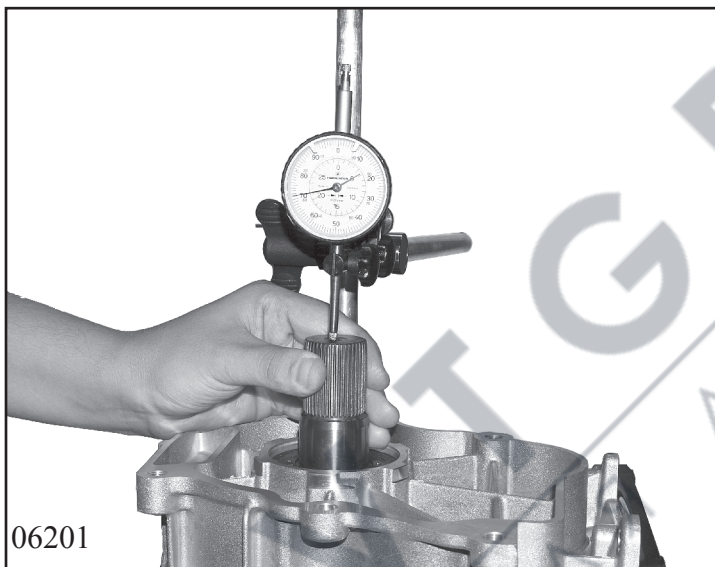

Example: (for 1.4.6)

A = 0,70 mm

C = 0,18 to 0,71

⇒ The washer is correct

Note!

For adjusting, see Specification 1068 700 130





1.5 Tightening torques

No.	Designation	Part List- Item-No.	Wrench size No.	Page	Tightening torque [Nm]
Alternative to oil pan plastik:					
1	Machine screw (oil pan - steel)	03.020/010	TORX - TX 27		12,0 Nm (±1,2Nm)
2	Screw plug (Oil filling plug)	03.010/130	Hexagon socket size = 17 mm		80,0 Nm (±8,0)
3	Screw plug (Oil drain plug)	03.010/140	Hexagon socket size = 5 mm		12,0 Nm (±1,2 Nm)
4	Machine screw (oil pan - plastic)	03.020/010	TORX - TX 27		10,0 Nm (±1,0Nm)





1.7 Special tools

OBJECT	Order-No. / Application	Remarks
<p style="text-align: center;">1</p>  <p style="text-align: center;">07001</p>	<p>5x46 004 126 Assembly tool (BMW) Shaft seal rear axle output</p>	<p>identical: 6 HP 26 X</p>
<p style="text-align: center;">2</p>  <p style="text-align: center;">07006</p>	<p>5x46 003 792 Assembly tool (Audi) Shaft seal rear axle output</p>	
<p style="text-align: center;">3</p>  <p style="text-align: center;">07005</p>	<p>5x46 003 777 Puller (Audi) Bearing rear axle output</p>	

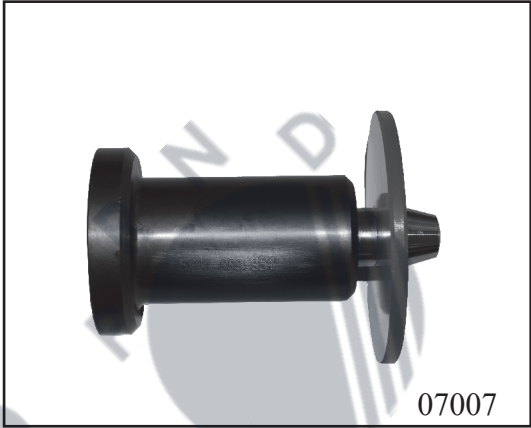
Remarks	Order-No. / Application	OBJECT
	5x46 003 354 Assembly tool (Audi) Bearing rear axle output	4 

2. Disassembly

2.1 Transmission disassembly according to component groups

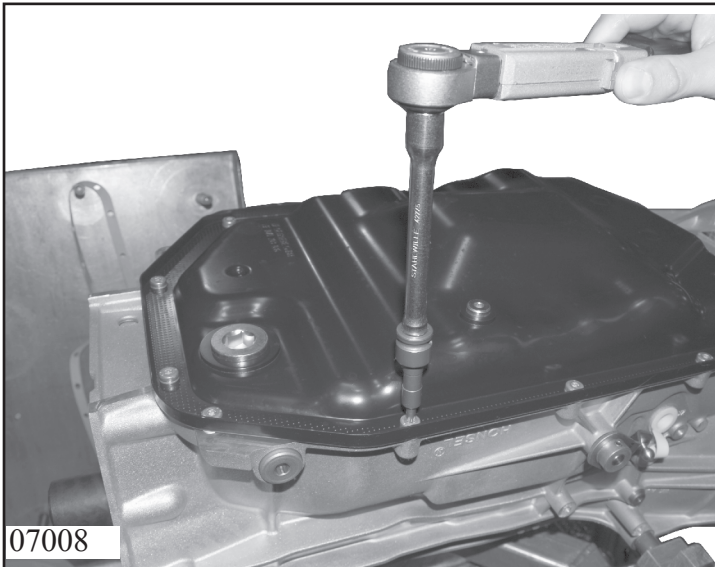

Turn the transmission with oil pan on top.
Unscrew the machine screws holding the
oil pan, lift it off and pull off the gasket.

(Wrench size = TORX - TX 27)

Oil pan - steel only

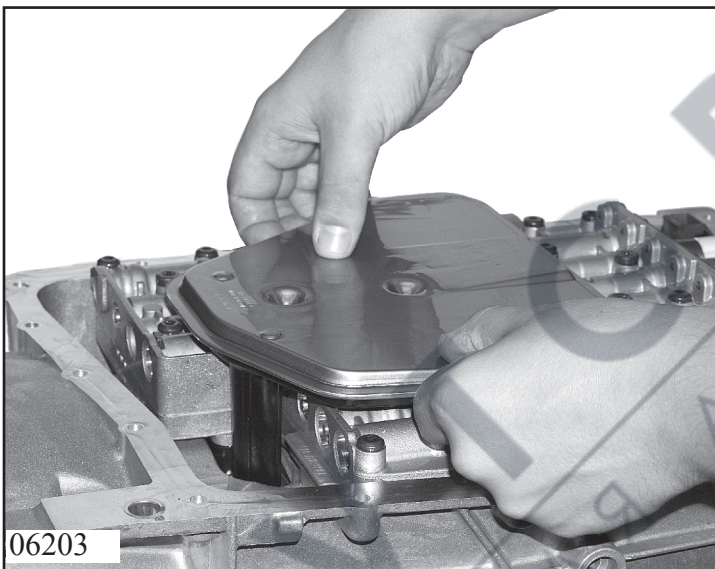

Remove oil filter.
Remove two magnets and cap from oil
pan.

Note:

Oil pan - steel - exchange oil filter

Oil pan - plastic - exchange complete oil
pan.



2.6 Rear axle output

2.6.1 Remove output shaft

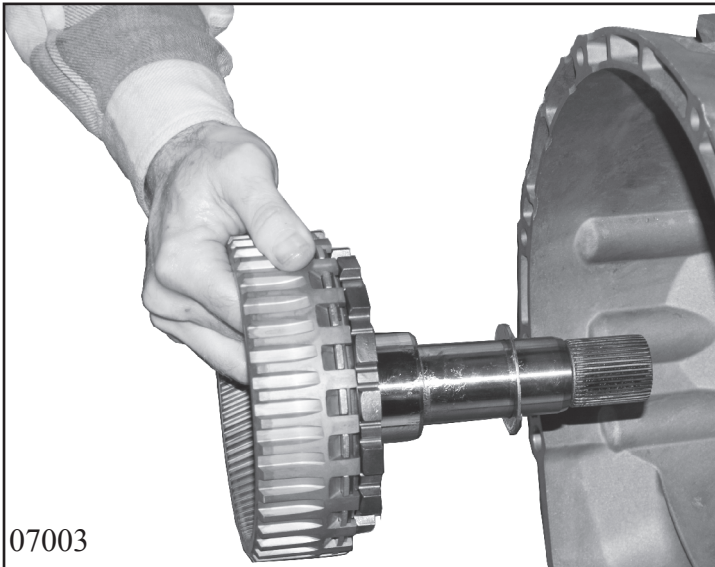

Take out, output shaft with spacer from gearbox housing.

Separate output shaft from internal gear by prising out the circlip.

2.6.2 Remove bearing (output)

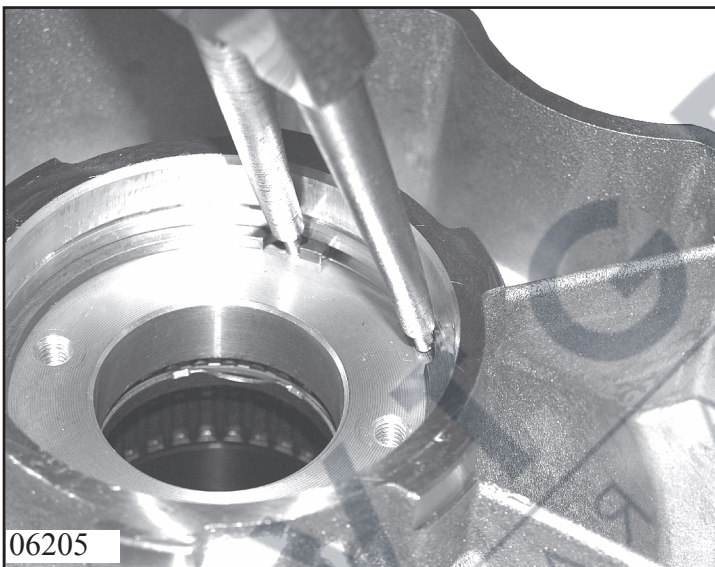

Prise out shaft seal (output) with suitable tool.

Turn the gearbox-housing by 90°.

Remove circlip of support shim.

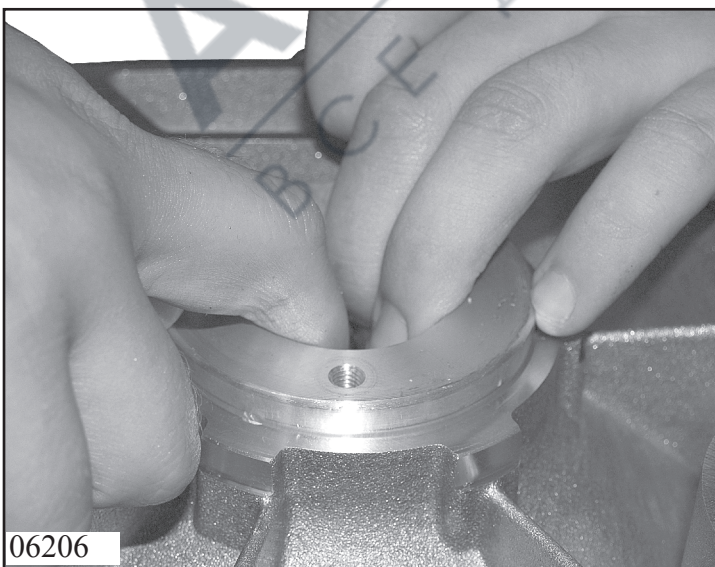

Extract support shim from gearbox housing.

Clip out thrust washer and needle bearing from support shim.

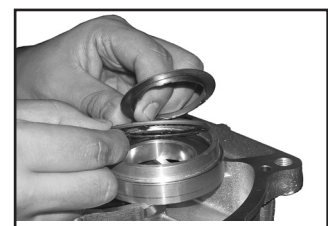



2.7 Gearbox housing and parking lock

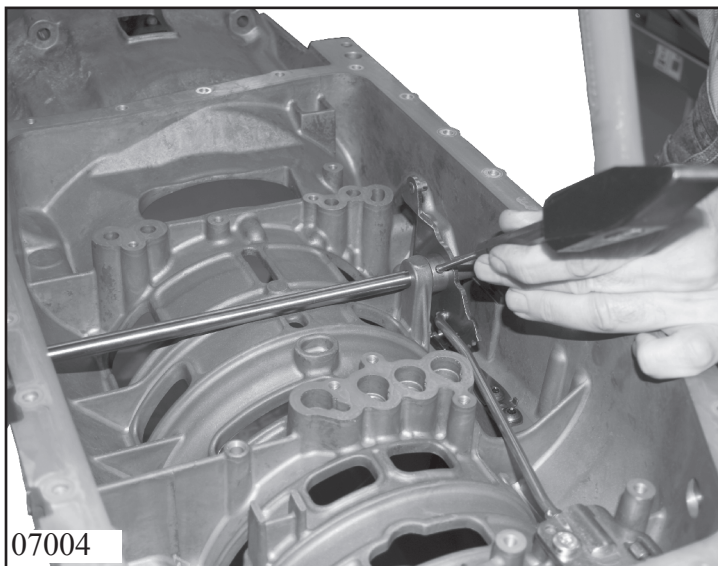

Note:

A long selector shaft has been installed in some series. In this case both shaft seals have to be replaced.

AVTGR
ВСЕ ДЛЯ АКПП



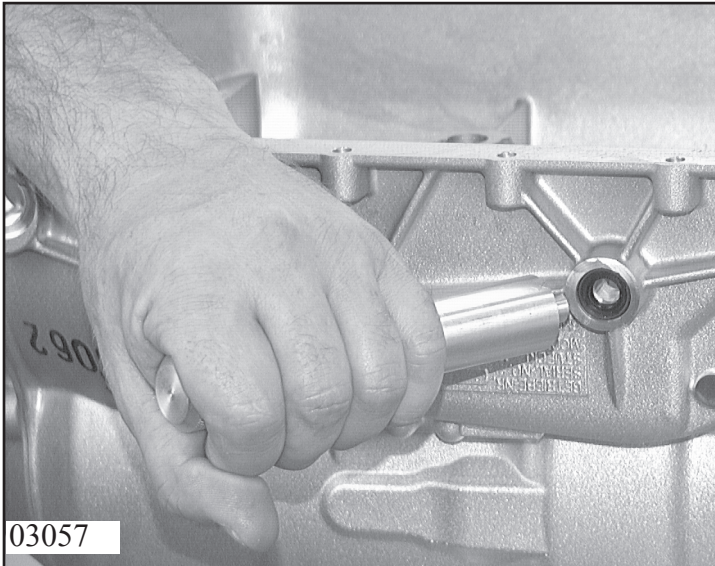

3. Assembly

3.1 Gearbox housing and parking

Install shaft seal ring 06.010 in gearbox housing with drive-in tool 5x46 909 345.

Note!

Only in case of a long selector shaft:
Fit both shaft seal rings 06.010 in the gearbox housing with a drive in tool 5x46 909 345.

AVTGR
ВСЕ ДЛЯ АКПП



3.2 Output shaft

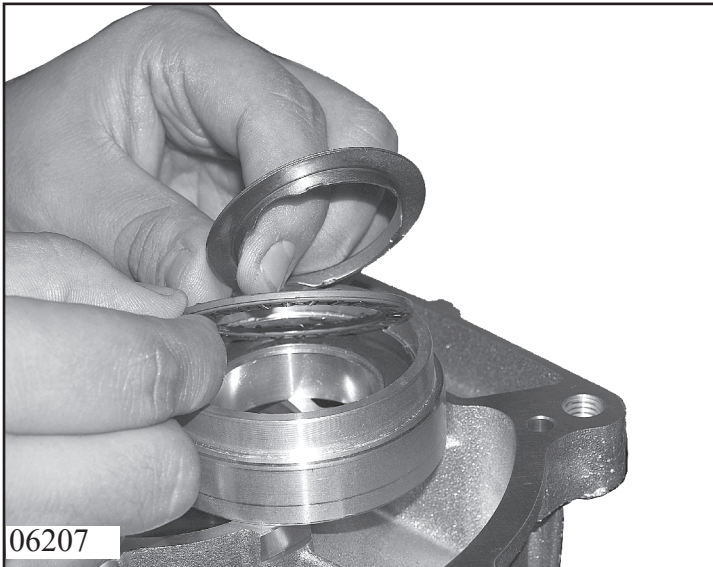

Insert axial needle bearing 14.070 into support shim 14.080.

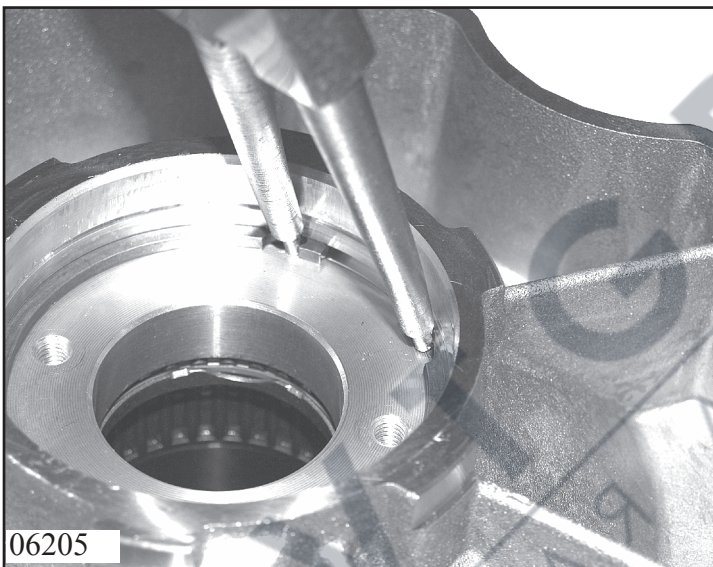

Turn the gearbox housing with converter-side downwards.
Press support shim into gearbox housing and secure with circlip 14.090.

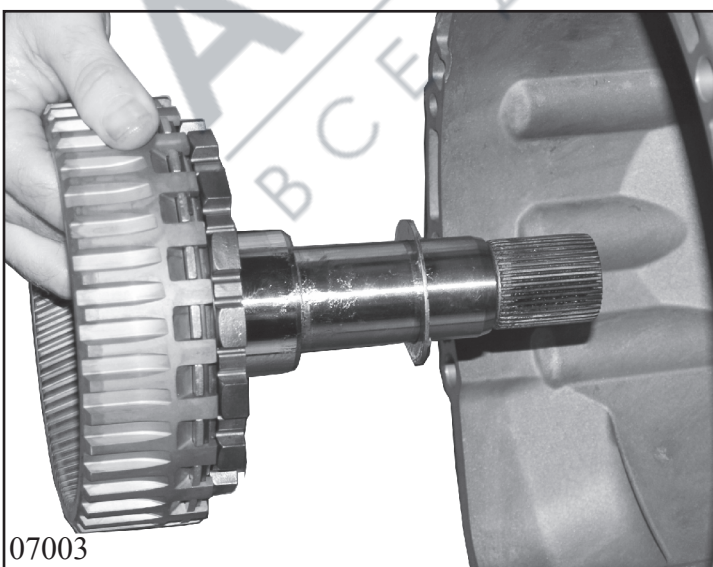

Install output shaft 42.190 into internal gear 42.170 and secure with circlip 42.180.

Insert shim 14.050 into output shaft.
Turn the gearbox housing by 90°.
Insert the output shaft cpl. in gearbox housing

(For adjusting work, see Chapter 1.4.6)

Note!

Insert transmission interior parts, oil supply and converter according to RM 6 HP 19 (consider converter fixing).

Insert shaft seal 14.110 with drive in tool
5x46 004 126 or 5x46 003 792.

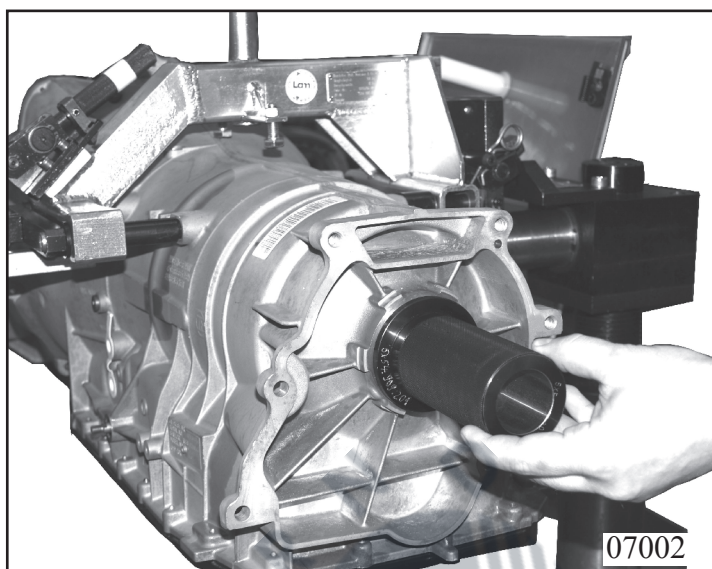

AVTGR
ВСЕ ДЛЯ АКПП

3.7 Fit oil pan

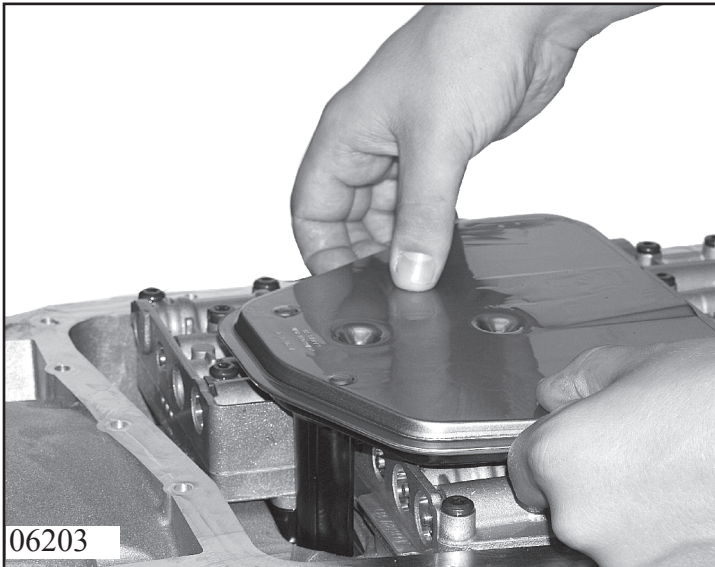

Assembly of the plastic oil pan, see repair manual 6 HP 19

Only valid for steel oil pan:

Turn transmission with oil pan upwards. Insert oil filter 27.600. Place two magnets 03.010/120 and cap 03.010/160 inside the oil pan.

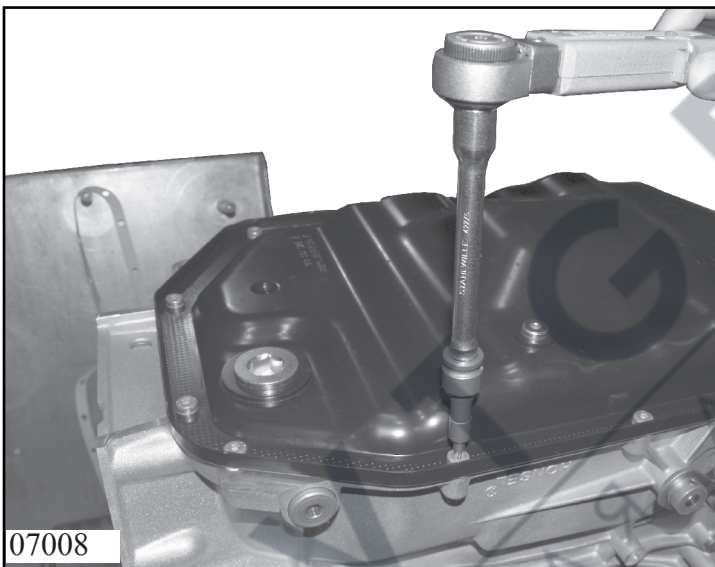

Fix gasket 03.050 on sealing surface. Put oil pan 03.010/110 and fix with screws 03.020/010.

Screw in screw plugs 03.010/130 and 03.010/140.

(For tightening torque, see **Chapter 1.5**)

